

Doodle Labs NO-DB-2 Wi-Fi Transceiver

Dual Band – 5.x and 2.4 GHz, MIMO, IEEE802.11n outdoor transceiver

Product Family Overview

Doodle Labs' portfolio of Outdoor Wi-Fi transceivers offers very reliable wireless performance. These transceivers have high transmit power to achieve long-range communication and withstand operation in outdoor environments. The transceivers are FCC, CE, and IC certified and have been deployed in numerous demanding applications.

Target Applications

The Doodle Labs Outdoor Wi-Fi transceivers meet the demanding needs of customers across a broad range of industries. Examples include:

- IoT applications
- Access Points for large area coverage
- Fixed wireless PtP links
- Mesh networking deployments
- Streaming HD video surveillance cameras
- Fixed wireless infrastructure for campuses

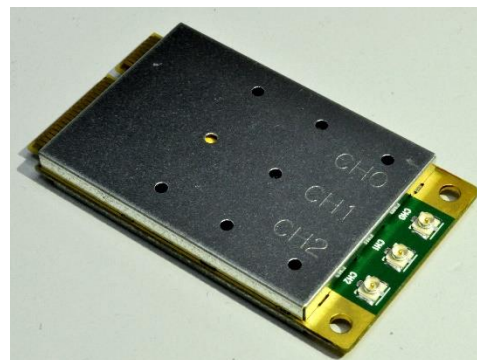

Features

Best-in-class features include:

- Modular FCC, CE, and IC certifications to expedite system integration and deployment
- Integrated LNA for high Rx sensitivity to pick up low energy signals from mobile phones
- Up to 27 dBm of RF power to communicate over a large area
- Extended temperature range from -40C to +60C for outdoor operation
- Electrical stress protection on antenna ports for outdoor operation

NO-DB-2 Specifications

Table 1. Technical Specifications.

Ordering Code	NO-DB-2U with U.FL connectors
Radio Configuration	2x2 MIMO, Dual Band
MAC Chipset	Qualcomm Atheros: QCA9590-BR4B with Extended Temperature range
Software Support	Open Source Linux Drivers ath9k for 11n models OpenWRT (Wireless Router/Linux OS)
Center Frequency Range	5.180 GHz ~ 5.825 GHz 2.412 GHz ~ 2.484 GHz This varies by the regulatory domain
Channel Bandwidth*	20, 40 MHz channels
Radio Modulation/Data Rates (Dynamic Link Adaptation)	802.11a : 6, 9, 12, 18, 24, 36, 48 and 54 Mbps (5.x GHz) 802.11n : MCS0-23 (5.x and 2.4 GHz) 802.11b/g : 1, 2, 5.5, 6, 9, 11, 12, 18, 24, 36, 48 and 54 Mbps (2.4 GHz)
802.11n version 2.0 Capabilities	<ul style="list-style-type: none"> • 802.11 dynamic frequency selection (DFS) as an AP and Client • Packet aggregation: A-MPDU (Tx/Rx), A-MSDU (Tx/Rx), Maximal ratio combining (MRC), Cyclic shift diversity (CSD), Frame aggregation, block ACK, 802.11e compatible bursting, Spatial multiplexing, cyclic-delay diversity (CDD), low-density parity check (LDPC), Space Time Block Code (STBC) • Phy data rates up to 450 Mbps (40 MHz channel)
Operating Modes	AP, Client, and Adhoc modes for Access Point, PtP, PtMP, and Mesh networks
MAC Protocol	TDD with Carrier Sense Multiple Access with Collision Avoidance (CSMA/CA)
Wireless Error Correction	FEC, ARQ
Wireless Data Security	128 bit AES, WEP, TKIP and WAPI hardware encryption. Support for IEEE 802.11d, e, h, i, k, r, v, w and time stamp standards

Table 2. Tx and Rx performance at 5 GHz.

Tx/Rx Specification	Radio Modulation	Coding Rate	Tx Power ($\pm 2\text{dBm}$) ²	Rx Sensitivity (Typ)
5 GHz (20 MHz Channel) – 11n models				
802.11a, STBC	BPSK	1/2	24	-94
802.11a	64 QAM	3/4	19	-77
802.11n, 802.11n	BPSK	1/2	24	-95
802.11n, 802.11n	16 QAM	3/4	22	-82
802.11n, 802.11n	64 QAM	5/6	19	-75
5 GHz (40 MHz Channel) – 11n models				
802.11n, 802.11n	BPSK	1/2	24	-91
802.11n, 802.11n	16 QAM	3/4	22	-79
802.11n, 802.11n	64 QAM	5/6	19	-72

Table 3. Tx and Rx performance at 2.4 GHz.

Tx/Rx Specification	Radio Modulation	Coding Rate	Tx Power ($\pm 2\text{dBm}$) ²	Rx Sensitivity (Typ)
2.4 GHz (20 MHz Channel) – 11n models				
802.11b Single Stream, STBC	1 Mbps	CCK	26	-100
802.11g	64 QAM	3/4	21	-79

802.11n	BPSK	1/2	26	-93
802.11n	16 QAM	3/4	26	-81
802.11n	64 QAM	5/6	23	-74
2.4 GHz (40 MHz Channel) – 11n models				
802.11n	BPSK	1/2	26	-90
802.11n	16 QAM	3/4	24	-78
802.11n	64 QAM	5/6	21	-71

Note 1: It is advantageous to use the smallest channel bandwidth that can support throughput requirements. Smaller bandwidths provide more channels to choose from and help avoid interference issues.

Note 2: Total Tx power for all streams. Max allowed Tx power depends on the regulatory domain.

Table 4. Additional RF performance information.

Antenna Signal Strength	-35 to -85 dBm (recommended), Absolute Maximum=+12 dBm
Integrated Antenna Port Protection	10 kV
Receiver LNA Gain	>10 dB
Receiver Adjacent Channel Rejection (ACR)	>18 dB @ 11a, 6 Mbps (Typ)
Receiver Alternate Channel Rejection (ALCR)	>35 dB @ 11a, 6 Mbps (Typ)
Receive chain Noise Figure	+6 dB
Transmitter Adjacent Channel Leakage Power Ratio (ACLR)	45 dB ($F_c \pm ChBW$)
Transmitter Spurious Emission Suppression	-40 dBc
RF Power control	In 0.5 dBm steps. Accuracy of power calibration loop ± 2 dBm. Each transceiver individually calibrated and tested.

Table 5. Physical, Environment, and Other Specifications.

Host Interface	miniPCI-Express 1.2 Standard
Host CPU Board	Any CPU board with miniPCIe interface with minimum 6 mm connector height
Operating Voltage	3.3 Volts from miniPCI-Express connector
Power Consumption	3.9W @ Max power, in continuous data transfer mode on all chains 2W @ 20 dBm power (ETSI max), in continuous data transfer mode on all chains 0.7W in continuous data receive mode 250 mW in Sleep mode

Shield case temperature range (Operating)	-40°C to +60°C
Humidity (Operating)	0% – 95% (Non-condensing)
Dimensions	30 x 50 x 5.3 mm, 12 grams. Mechanical drawings and 3D-CAD files available upon request
MTBF	25 years
Regulatory Requirements	Designed and verified to meet various regulatory requirements. Formal testing and approval is required based on the integrator’s particular host platform and antenna type. The integrator is also responsible for obtaining all required regulatory approvals in target markets for the finished product.
FCC ID	2AG87NM-DB-3N. DFS compliance in both Master and Client modes.
CE/ETSI	Conforms with all the requirements of the European Directive 1999/5/EC – EN 301 893 V1.8.1, EN 300 328 V.1.8.1, EN 301 489-1 V1.9.2, EN 301 489-17 V2.2.1, EN 60950-1:2006 + A11:2009 + A1:2010 + A12:2011+ A2:2013
Industry Canada (IC)	21411-NMDB3
RoHS/WEEE Compliance	Yes. 100% Recyclable/Biodegradable packaging

System Integration

Figure 3. System Integration Block Diagram.

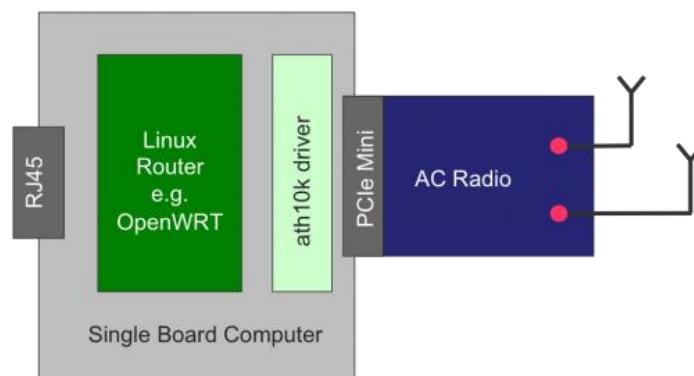

As shown in the block diagram, the modular nature of the MIMO radio transceivers allows for accelerated development of the wireless modem. An embedded Single Board Computer with standard miniPCI-Express interface is required. The Linux distribution OpenWRT has evolved over time and provides advanced features in a wireless router. It is a stable distribution and many OEMs are using OpenWRT as a starting point and then customize further for their application. The distribution includes the ath9k driver to interface with the MIMO transceivers. Both OpenWRT and open source drivers (ath9k and ath10k) have extensive online documentation available. User group forums also provide responsive technical support.

Portfolio Index

Doodle Labs' Outdoor Wi-Fi transceiver portfolio provides configurations for a vast variety of project needs. All models are form-factor compatible. For information on other models, please visit - <http://www.doodlelabs.com/products/wi-fi-band-radio-transceivers/>



Компания «ЭлектроПласт» предлагает заключение долгосрочных отношений при поставках импортных электронных компонентов на взаимовыгодных условиях!

Наши преимущества:

- Оперативные поставки широкого спектра электронных компонентов отечественного и импортного производства напрямую от производителей и с крупнейших мировых складов;
- Поставка более 17-ти миллионов наименований электронных компонентов;
- Поставка сложных, дефицитных, либо снятых с производства позиций;
- Оперативные сроки поставки под заказ (от 5 рабочих дней);
- Экспресс доставка в любую точку России;
- Техническая поддержка проекта, помощь в подборе аналогов, поставка прототипов;
- Система менеджмента качества сертифицирована по Международному стандарту ISO 9001;
- Лицензия ФСБ на осуществление работ с использованием сведений, составляющих государственную тайну;
- Поставка специализированных компонентов (Xilinx, Altera, Analog Devices, Intersil, Interpoint, Microsemi, Aeroflex, Peregrine, Syfer, Eurofarad, Texas Instrument, Miteq, Cobham, E2V, MA-COM, Hittite, Mini-Circuits, General Dynamics и др.);

Помимо этого, одним из направлений компании «ЭлектроПласт» является направление «Источники питания». Мы предлагаем Вам помощь Конструкторского отдела:

- Подбор оптимального решения, техническое обоснование при выборе компонента;
- Подбор аналогов;
- Консультации по применению компонента;
- Поставка образцов и прототипов;
- Техническая поддержка проекта;
- Защита от снятия компонента с производства.



Как с нами связаться

Телефон: 8 (812) 309 58 32 (многоканальный)

Факс: 8 (812) 320-02-42

Электронная почта: org@eplast1.ru

Адрес: 198099, г. Санкт-Петербург, ул. Калинина, дом 2, корпус 4, литера А.