

Product Manual

PSE NO Switch

CONTENTS

CONTENTS 1

1 PRODUCT DESCRIPTION 3

1.1 Functional Description: NO Switch3

1.2 Functional Description: Illumination4

2 TECHNICAL DATA AND DIMENSIONAL DRAWINGS 5

2.1 Technical Data5

2.2 Component dimensions7

2.3 Hole Dimensions.....13

2.4 Switching Symbols: Illumination14

2.5 Accessories.....16

3 ORDER NUMBERS 17

3.1 M16 Series17

3.2 M19 Series17

3.3 M22 Series17

3.4 M22 / M24 / M27 / M30 with Ring Illumination18

3.5 Lettering:20

4 PACKAGING 22

5 QUALIFICATION TESTS..... 23

5.1 IP Protection Class23

5.2 IK Protection Class23

5.3 Salt-Spray Test.....23

5.4 Hygienic Switches for Food Processing Equipment23

Changes that contribute to technical improvement are subject to alternations.

Page	Date of issue	Author:	Date of change:	Changed by:	Change No.	Datasheet No.	Index
1 of 24	19.05.2008	SHO	23.08.11	SHO	10474	105.9524.200	f

6	APPROVALS	24
7	COMPLIANCE	24

Changes that contribute to technical improvement are subject to alternations.

Page	Date of issue	Author:	Date of change:	Changed by:	Change No.	Datasheet No.	Index
2 of 24	19.05.2008	SHO	23.08.11	SHO	10474	105.9524.200	f

1 PRODUCT DESCRIPTION

- Variety of design options concerning size, colour, shape, illumination, connection or lettering
- especially ideal for use in harsh environments
- high reliability, long lifetime with more than 30 mill. actuations
- no maintenance costs, since no mechanical wear parts
- easy to clean due to a tightly closed surface (IP 69K)

1.1 Functional Description: NO Switch

The piezo switch is based on the functional principle of the piezoelectric crystal. The action of force on the piezo disk causes a voltage to be induced due to a charge transfer. The voltage generated is converted by the electronic connection into a polarity-neutral, electronic switch contact. During the voltage drop, the electronic switch contact is closed for the specified pulse duration. After this, the electronic switch contact opens again, even if the force is still present. The period that the electronic switch contact remains closed depends on the actuating speed and force as well as on the duration of actuation.

Diagram of an NO switch:

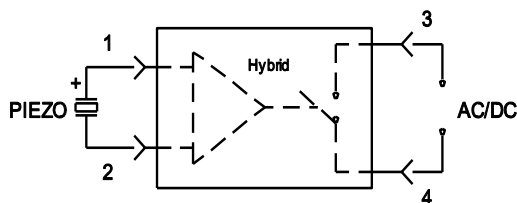

The piezo disk is connected to the terminals 1 and 2. The electric circuit to be switched is connected at the terminals 3 and 4. This can be either direct voltage (DC) or alternating voltage (AC). If a pulse is applied to the piezo disk, terminal 1 becomes positive in relation to terminal 2 due to the voltage generated. The integrated switching element controls the electric circuit to be switched.

In the neutral position of the piezo switching element, the terminals 3 and 4 are non-conductive, and initial contact resistance is greater than 10 MOhm. When the piezo disk is actuated, the initial contact resistance is reduced to less than 20 Ohm.

When actuating the piezo disk, the resistance between terminals 3 and 4 is therefore changed from high resistance → low resistance → high resistance.

This corresponds in principle to the function of a conventional **NO pushbutton switch**.

Changes that contribute to technical improvement are subject to alternations.							
Page	Date of issue	Author:	Date of change:	Changed by:	Change No.	Datasheet No.	Index
3 of 24	19.05.2008	SHO	23.08.11	SHO	10474	105.9524.200	f

1.2 Functional Description: Illumination

Ring Illumination

Single or bi-colored ring illumination is possible for the PSE switches. When equipped with two colors, it is possible to either switch between the colors or to achieve a combination color, depending on the type of activation.

For example: Diodes of group 1 = red and diodes of group 2 = green

Only group 1 is activated	→	Ring has red illumination
Only group 2 is activated	→	Ring has green illumination
Both groups are activated at the same time	→	Ring has orange illumination

Red cable	=	Supply voltage: red LEDs
Green cable	=	Supply voltage: green LEDs
Black cable	=	Minus for all LEDs
White cable	=	Switch contact

[Terminal layout](#) see page 14 section 2.4 Switching Symbols Illumination

Special type 5 VDC upon request

Point Illumination

When illuminating the PSE switch, either a single-color LED (2 pins) is used or a bi-colored LED (3 pins). If a single-color LED is used, cable No. 2 is not needed (see section 2.4 Switching Symbols: Illumination – Point Illumination).

Switching between colors can be achieved by appropriate activation.

Changes that contribute to technical improvement are subject to alternations.							
Page	Date of issue	Author:	Date of change:	Changed by:	Change No.	Datasheet No.	Index
4 of 24	19.05.2008	SHO	23.08.11	SHO	10474	105.9524.200	f

2 TECHNICAL DATA AND DIMENSIONAL DRAWINGS

2.1 Technical Data

Electrical Data		
Switching Voltage max.	(VAC/DC)	42/60
Switching Current max.	(mA)	100
Rated Breaking Capacity	(W)	1
Lifetime (at Rated Breaking Capacity)	(Mio.)	20
Switch resistance off (OFF=not actuated)	(MΩ)	>10
Switch resistance on (Ta=25°C) (ON=actuated)	(Ω)	<20
Capacity	(nF)	5
NO Pulse Time (depending on the actuating force, time and speed)	(ms)	20-1000
Contact Configuration		polarity-free
Switch Function		NO switch

Mechanical Data		
Actuating Force (at ambient temperature)	(N)	≤3 ¹⁾
Actuating Travel	(mm)	0.002
Torque	(Nm)	2.5
IK Protection Class	(IK)	02

Climatic Data		
Operating Temperature	(°C)	-40 to +85
Storage Temperature	(°C)	-40 to +85
IP Degree of Protection Front Side hose water (1m water column) (IEC/DIN/EN 60529)	(IP)	67
IP Degree of Protection Front Side submerged (DIN 40050-9:1993 High-pressure cleaning test)	(IP)	69K
Degree of Protection DIN EN 60069-2-30 Db (Moist heat (air test with 55°C / 93% humidity))		front side / rear side

¹⁾ At temperatures lower than -10°C, the actuating force increases 2- to 4-fold.

Material (Individual Part)	Material ²⁾
Housing (depending on type)	Stainless Steel
	Anodized aluminum
	Polyamide
Actuating Area / Insert (with ring illumination)	Stainless steel
	Anodized aluminum
Illuminated Ring (with ring illumination)	Polyamide

²⁾ *When using the switch in a saline or chloric environment, special materials must be used. Items available upon request.*

2.2 Component dimensions

2.2.1 M16 Series with Finger Guidance

with Pins

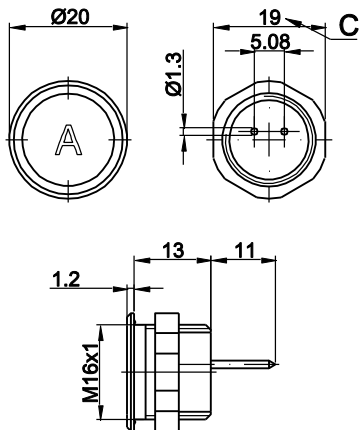

with Crimp Terminal male

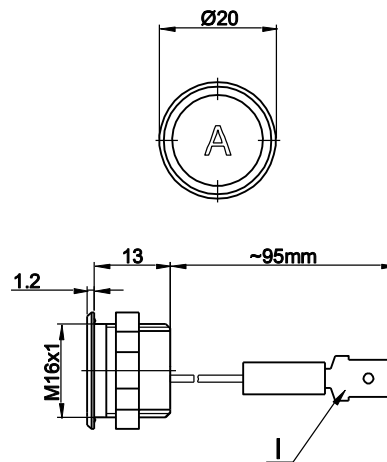

with AMP ¹⁾

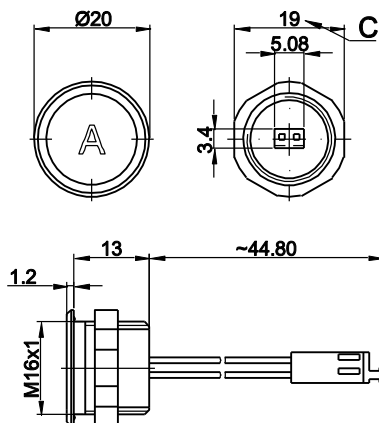

Legend:

- A = Illumination Area
- B = Actuating Area
- C = Width Across Flats
- I = Crimp Terminal male 6.3x0.8

Lettering:

- either with/without lettering
- position of the connections with respect to the position of the lettering is not defined

¹⁾ Version available on request

Changes that contribute to technical improvement are subject to alternations.							
Page	Date of issue	Author:	Date of change:	Changed by:	Change No.	Datasheet No.	Index
7 of 24	19.05.2008	SHO	23.08.11	SHO	10474	105.9524.200	f

2.2.1.1 Design Possibilities for Housing Geometry: M16

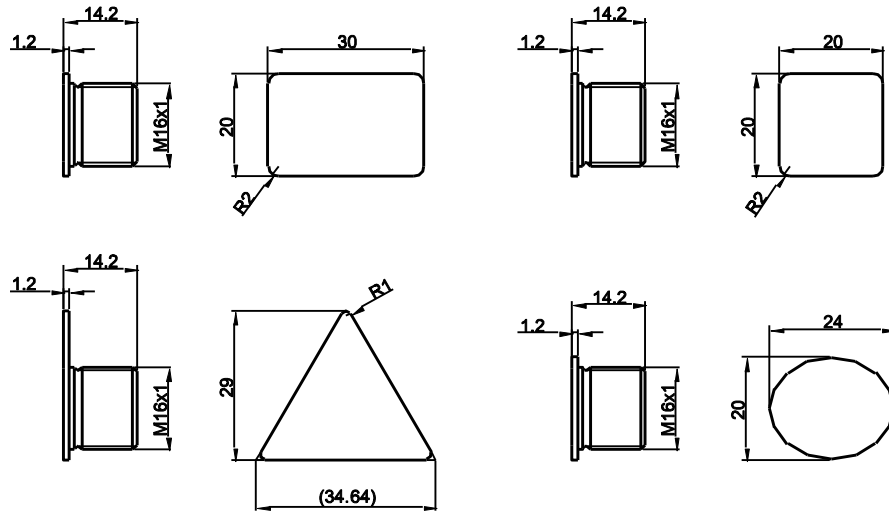

2.2.1.2 Design Possibilities for Actuating Area

with finger guidance
(standard)

without finger guidance
(upon request)

elevated front design: M19
(standard, others upon request)

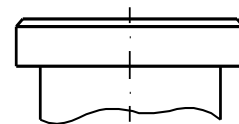
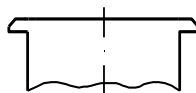
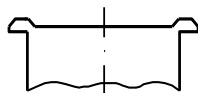

2.2.1.3 Connection variants

- Wire (Standard: 0.14 mm² / 200 mm wire-length)
- Pins (with Connection Terminal 0701.9225)
- Crimp Terminal male 6.3 x 0.8 mm
- AMP

Changes that contribute to technical improvement are subject to alternations.							
Page	Date of issue	Author:	Date of change:	Changed by:	Change No.	Datasheet No.	Index
8 of 24	19.05.2008	SHO	23.08.11	SHO	10474	105.9524.200	f

2.2.2 M19 Series

with Pins

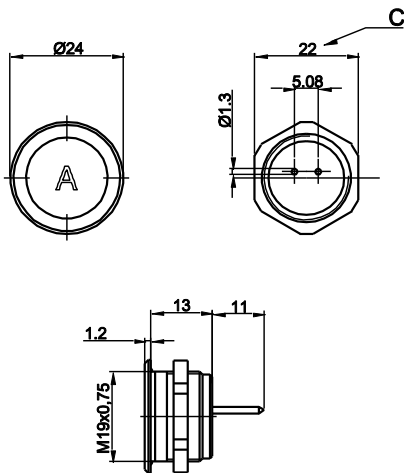

with Crimp Terminal male ¹⁾

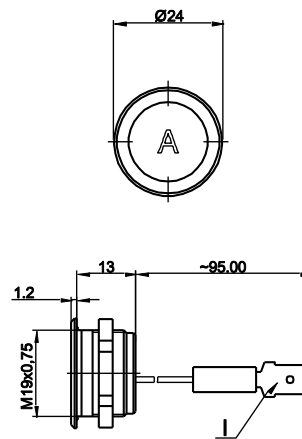

Cable with Faston, elevated front design

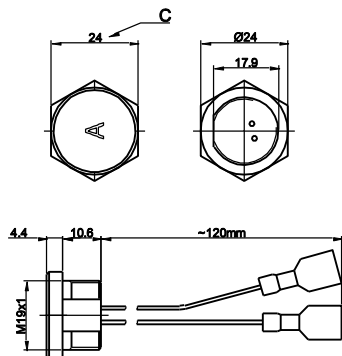

Terminal:
Crimp Terminal female Ultrafast red 6,3x0,8

Legend:

- A = Illumination Area
- B = Actuating Area
- C = Width Across Flats
- I = Crimp Terminal male 6.3x0.8

Lettering:

- either with/without lettering
- position of the connections with respect to the position of the lettering is not defined

¹⁾ Version available on request

Changes that contribute to technical improvement are subject to alternations.							
Page	Date of issue	Author:	Date of change:	Changed by:	Change No.	Datasheet No.	Index
9 of 24	19.05.2008	SHO	23.08.11	SHO	10474	105.9524.200	f

2.2.3 M22 Series

with Pins

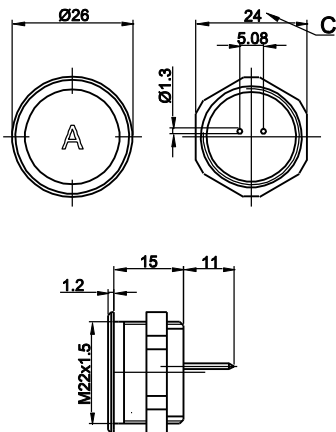

with Wire

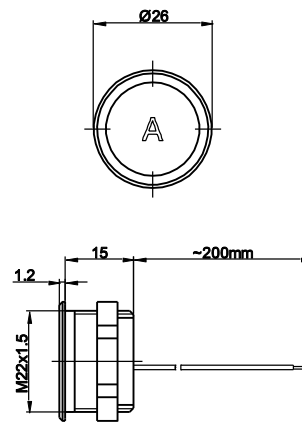

with Crimp Terminal male ¹⁾

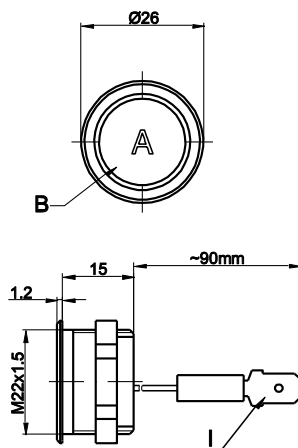

Point Illumination with Crimp Terminal male

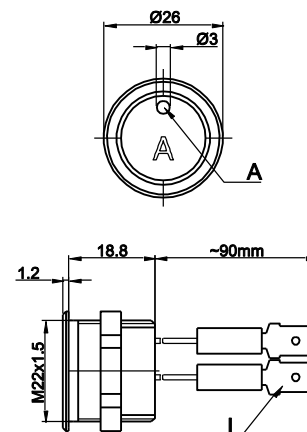

For terminal layout see page 14

Legend:

- A = Illumination Area
- B = Actuating Area
- C = Width Across Flats
- I = Crimp Terminal male 6.3x0.8

Lettering:

- either with/without lettering
- position of the connections with respect to the position of the lettering is not defined

¹⁾ Version available on request

Changes that contribute to technical improvement are subject to alternations.							
Page	Date of issue	Author:	Date of change:	Changed by:	Change No.	Datasheet No.	Index
10 of 24	19.05.2008	SHO	23.08.11	SHO	10474	105.9524.200	f

Ring Illumination with Wires

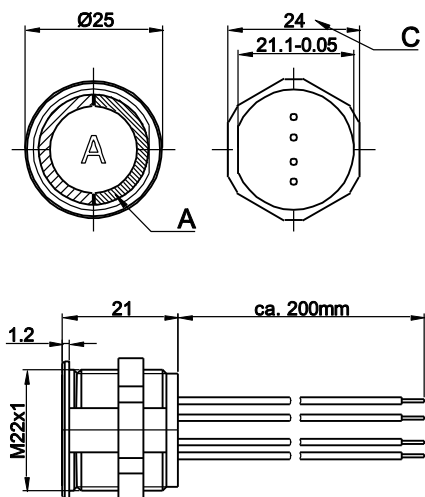

Ring Illumination with Plug Connector

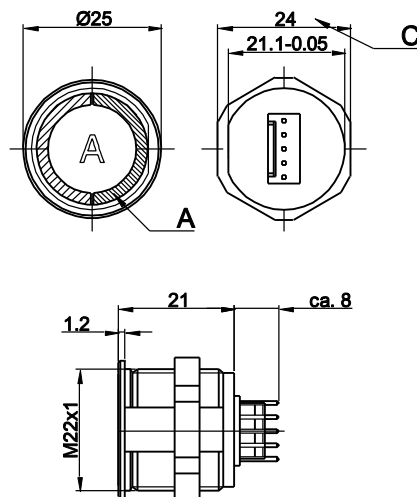

Terminal:
Molex 22-23-2051
6373 Serie

For terminal layout see page 15

Legend:

- A = Illumination Area
- B = Actuating Area
- C = Width Across Flats
- I = Crimp Terminal male 6.3x0.8

Lettering:

- either with/without lettering
- position of the connections with respect to the position of the lettering is not defined

Changes that contribute to technical improvement are subject to alternations.							
Page	Date of issue	Author:	Date of change:	Changed by:	Change No.	Datasheet No.	Index
11 of 24	19.05.2008	SHO	23.08.11	SHO	10474	105.9524.200	f

2.2.4 M24 / M27 / M30 Series with Ring Illumination

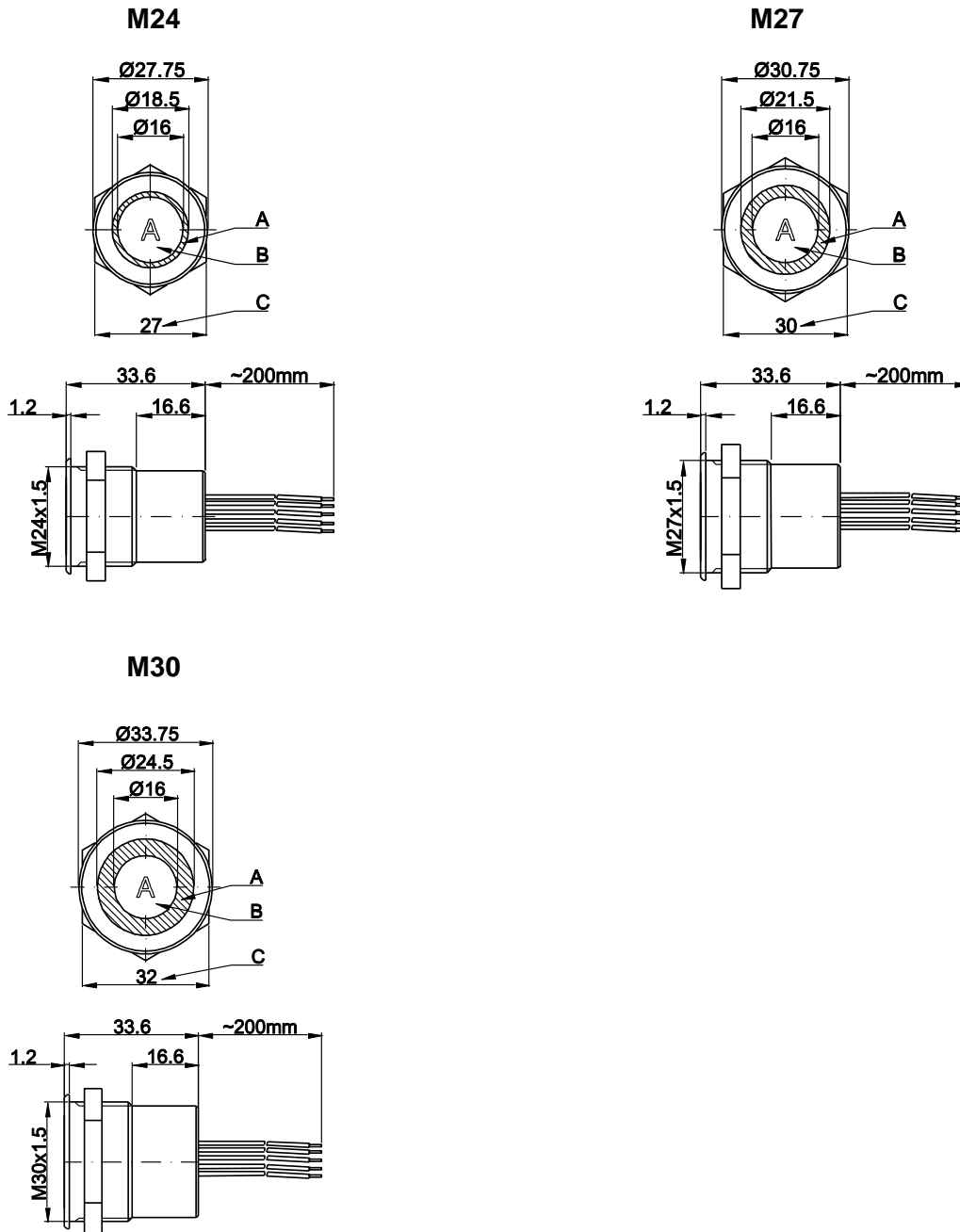

For terminal layout see page 14

Legend:

- A = Illumination Area
- B = Actuating Area
- C = Width Across Flats
- I = Crimp Terminal male 6.3x0.8

Lettering:

- either with/without lettering
- position of the connections with respect to the position of the lettering is not defined

Changes that contribute to technical improvement are subject to alternations.							
Page	Date of issue	Author:	Date of change:	Changed by:	Change No.	Datasheet No.	Index
12 of 24	19.05.2008	SHO	23.08.11	SHO	10474	105.9524.200	f

2.3 Hole Dimensions

M16

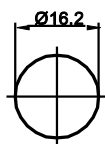

M24

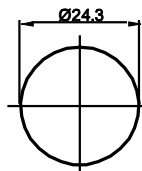

M19

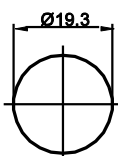

M27

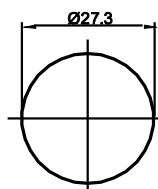

M22

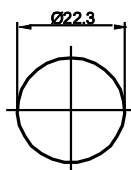

M30

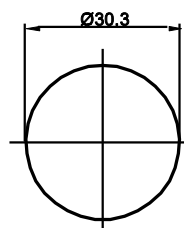

M22 RI

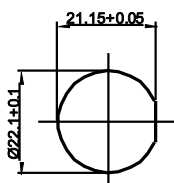

Changes that contribute to technical improvement are subject to alternations.							
Page	Date of issue	Author:	Date of change:	Changed by:	Change No.	Datasheet No.	Index
13 of 24	19.05.2008	SHO	23.08.11	SHO	10474	105.9524.200	f

2.4 Switching Symbols: Illumination

Ring Illumination for the M24, M27, M30, 12/24 VDC Series

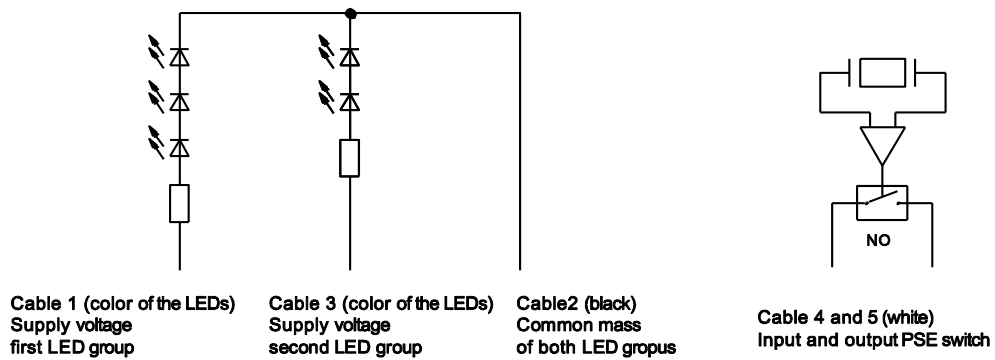

Special Types: 5 VDC

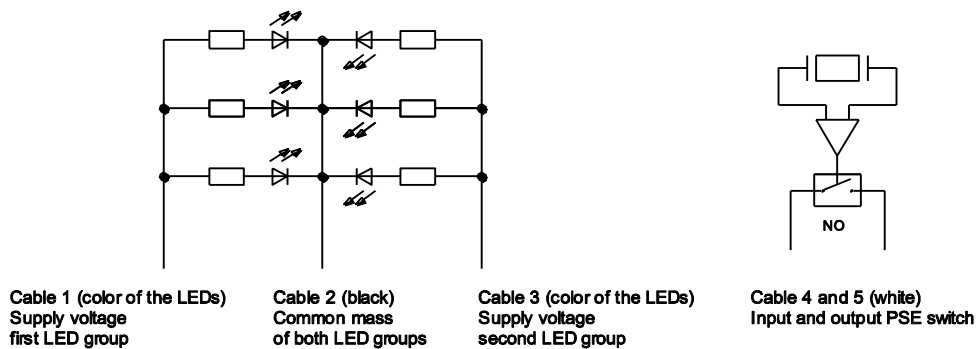

Point Illumination

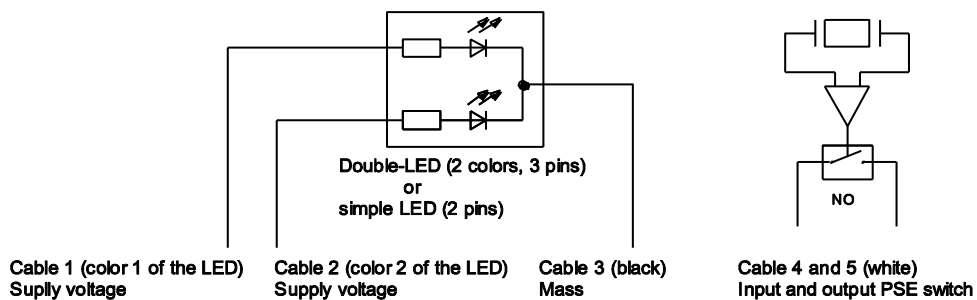

Changes that contribute to technical improvement are subject to alternations.							
Page	Date of issue	Author:	Date of change:	Changed by:	Change No.	Datasheet No.	Index
14 of 24	19.05.2008	SHO	23.08.11	SHO	10474	105.9524.200	f

Ring Illumination for the M22, 12/24 VDC Series with Wires

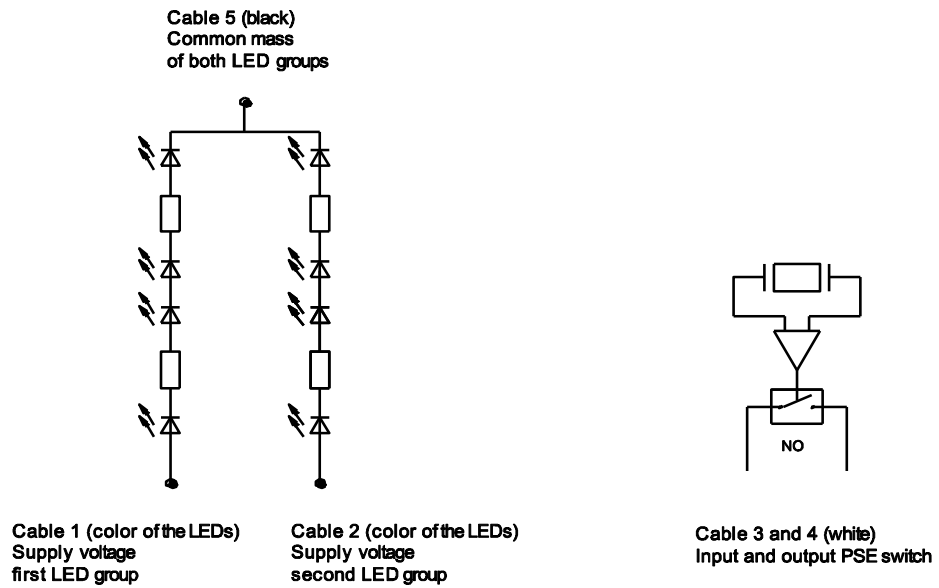

Ring Illumination for the M22, 12/24 VDC Series with Quick Connect Terminal

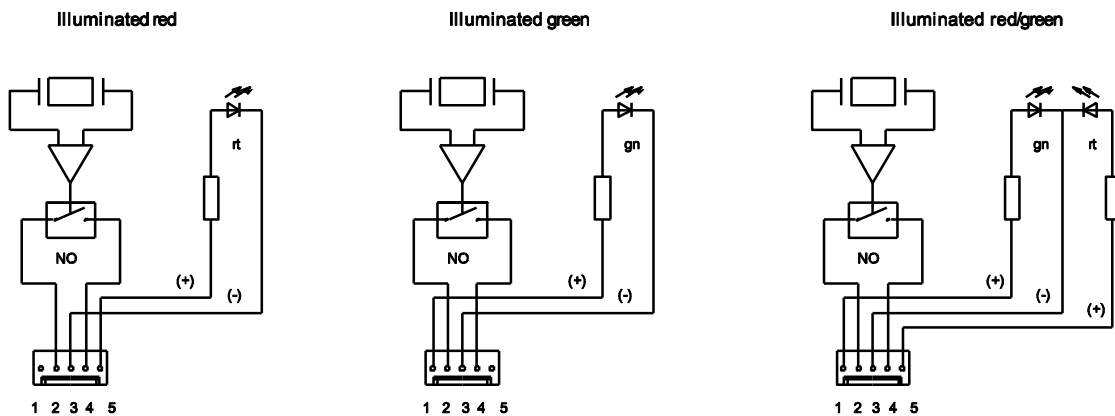

Changes that contribute to technical improvement are subject to alternations.

Page	Date of issue	Author:	Date of change:	Changed by:	Change No.	Datasheet No.	Index
15 of 24	19.05.2008	SHO	23.08.11	SHO	10474	105.9524.200	f

2.5 Accessories

Connection Terminal for version with pins

Order number: 0701.9225

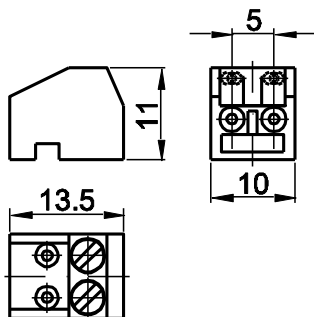

Changes that contribute to technical improvement are subject to alternations.							
Page	Date of issue	Author:	Date of change:	Changed by:	Change No.	Datasheet No.	Index
16 of 24	19.05.2008	SHO	23.08.11	SHO	10474	105.9524.200	f

3 ORDER NUMBERS

3.1 M16 Series

Item Number	Function	Connection	Housing Material	Housing Color
1241.2350	NO	Pins	Plastic	Red
1241.2351	NO	Pins	Plastic	White
1241.2352	NO	Pins	Plastic	Aluminum natural
1241.2353	NO	Pins	Plastic	Black
1241.2411.1	NO	Pins	Aluminum	Gold
1241.2411.3	NO	Pins	Aluminum	Red
1241.2411.4	NO	Pins	Aluminum	Blue
1241.2411.5	NO	Pins	Aluminum	Green
1241.2411.7	NO	Pins	Aluminum	Black
1241.2411.8	NO	Pins	Aluminum	Aluminum natural
1241.2611	NO	Pins	Stainless Steel	
1241.3000	NO	Crimp Terminal male	Aluminum	Red
1241.3001	NO	Crimp Terminal male	Aluminum	Green
1241.3002	NO	Crimp Terminal male	Aluminum	Black
1241.3003	NO	Crimp Terminal male	Aluminum	Aluminum natural

3.2 M19 Series

Item Number	Function	Connection	Housing Material	Housing Color
1241.3123	NO	Pins	Aluminum	Aluminum natural
1241.5003	NO	Cable with Faston	Aluminum	Aluminum natural
1241.3388	NO	Pins	Stainless Steel	

3.3 M22 Series

3.3.1 M22 non-illuminated

Item Number	Function	Connection	Housing Material	Housing Color
1241.3005	NO	Pins	Aluminum	Red
1241.3006	NO	Pins	Aluminum	Green
1241.3007	NO	Pins	Aluminum	Black
1241.3008	NO	Pins	Aluminum	Aluminum natural
1241.3075	NO	Pins	Stainless Steel	
1241.3593	NO	Wire	Aluminum	Aluminum natural

The listed item numbers represent a selection from the range of piezo switches.
Other mounting diameters, materials, colors and connections are available upon request.

Changes that contribute to technical improvement are subject to alternations.							
Page	Date of issue	Author:	Date of change:	Changed by:	Change No.	Datasheet No.	Index
17 of 24	19.05.2008	SHO	23.08.11	SHO	10474	105.9524.200	f

3.3.2 M22 with Point Illumination

Item Number	Function	Connection	Housing Material	Housing Color	Illumination	Voltage
1241.3020.M	NO	Crimp Terminal male	Aluminum	Aluminum natural	Red	24 VDC
1241.3047.M	NO	Crimp Terminal male	Aluminum	Aluminum natural	Yellow	24 VDC
1241.3089.M	NO	Crimp Terminal male	Aluminum	Aluminum natural	Green	24 VDC
1241.3244.M	NO	Crimp Terminal male	Aluminum	Aluminum natural	Blue	24 VDC
1241.3166.M	NO	Crimp Terminal male	Aluminum	Red	Red	24 VDC
1241.3167.M	NO	Crimp Terminal male	Aluminum	Green	Green	24 VDC
1241.3222.M	NO	Crimp Terminal male	Aluminum	Gold	Yellow	24 VDC
1241.3594.M	NO	Wire	Stainless Steel		Green	24 VDC

3.4 M22 / M24 / M27 / M30 with Ring Illumination

3.4.1 M22 With Ring Illumination

Item Number	Function	Connection	Housing Material	Housing Color	Illumination	Voltage
1241.3250	NO	Wire	Aluminum	Aluminum natural	Red	12 VDC
1241.3251	NO	Wire	Aluminum	Aluminum natural	Green	12 VDC
1241.3252	NO	Wire	Aluminum	Aluminum natural	Red/Green	12 VDC
1241.3253	NO	Plug Connector	Aluminum	Aluminum natural	Red	12 VDC
1241.3254	NO	Plug Connector	Aluminum	Aluminum natural	Green	12 VDC
1241.3255	NO	Plug Connector	Aluminum	Aluminum natural	Red/Green	12 VDC
1241.3256	NO	Wire	Aluminum	Aluminum natural	Red	24 VDC
1241.3257	NO	Wire	Aluminum	Aluminum natural	Green	24 VDC
1241.3258	NO	Wire	Aluminum	Aluminum natural	Red/Green	24 VDC
1241.3259	NO	Plug Connector	Aluminum	Aluminum natural	Red	24 VDC
1241.3260	NO	Plug Connector	Aluminum	Aluminum natural	Green	24 VDC
1241.3261	NO	Plug Connector	Aluminum	Aluminum natural	Red/Green	24 VDC
1241.3390	NO	Wire	Aluminum	Aluminum natural	Blue	12 VDC*
1241.3413	NO	Wire	Aluminum	Aluminum natural	Blue	24 VDC

*Illumination blue 12 VDC: voltage supply 12 VDC +10% / -1%

*The listed item numbers represent a selection from the range of piezo switches.
Other mounting diameters, materials, colors and connections are available upon request.*

Changes that contribute to technical improvement are subject to alternations.							
Page	Date of issue	Author:	Date of change:	Changed by:	Change No.	Datasheet No.	Index
18 of 24	19.05.2008	SHO	23.08.11	SHO	10474	105.9524.200	f

3.4.2 M24 Series

Item Number	Function	Connection	Housing Material	Housing Color	Illumination	Voltage
1241.3010	NO	Wire	Aluminum	Aluminum natural	Red/Green	24 VDC
<i>1241.3134</i>	<i>NO</i>	<i>Wire</i>	<i>Aluminum</i>	<i>Aluminum natural</i>	<i>Red/Green</i>	<i>12 VDC</i>

3.4.3 M27 Series

Item Number	Function	Connection	Housing Material	Housing Color	Illumination	Voltage
1241.3011	NO	Wire	Aluminum	Aluminum natural	Red/Green	24 VDC
<i>1241.3138</i>	<i>NO</i>	<i>Wire</i>	<i>Aluminum</i>	<i>Aluminum natural</i>	<i>Red/Green</i>	<i>12 VDC</i>

3.4.4 M30 Series

Item Number	Function	Connection	Housing Material	Housing Color	Illumination	Voltage
1241.3012	NO	Wire	Aluminum	Aluminum natural	Red/Green	24 VDC
<i>1241.3230</i>	<i>NO</i>	<i>Wire</i>	<i>Aluminum</i>	<i>Aluminum natural</i>	<i>Red/Green</i>	<i>12 VDC</i>
1241.3189	NO	Wire	Aluminum	Aluminum natural	Blue	24 VDC
1241.3237	NO	Wire	Stainless steel		Blue	24 VDC

- *Items in italics are available upon request*
- *Other supply voltages available upon request*

*The listed item numbers represent a selection from the range of piezo switches.
Other mounting diameters, materials, colors and connections are available upon request.*

3.5 Lettering:

The last three figures of the order number relate to the type of lettering.

001-074 Standard Lettering
101- Customized Lettering

Example for ordering with lettering

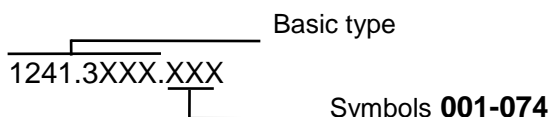

Order Indices for Lettering

001= A	016= P	031= 4	046= \updownarrow	061= EIN
002= B	017= Q	032= 5	047= \rightarrow	062= AUS
003= C	018= R	033= 6	048= \leftarrow	063= AUF
004= D	019= S	034= 7	049= \downarrow	064= AB
005= E	020= T	035= 8	050= \uparrow	065= ON
006= F	021= U	036= 9	051= %	066= OFF
007= G	022= V	037= +	052= $\sqrt{\quad}$	067= UP
008= H	023= W	038= -	053= CTRL	068= DOWN
009= I	024= X	039= .	054= RETURN	069= HIGH
010= J	025= Y	040= x	055= SHIFT	070= LOW
011= K	026= Z	041= ÷	056= LOCK	071= ON/OFF
012= L	027= 0	042= *	057= STOP	072= START
013= M	028= 1	043= =	058= ENTER	073= RESET
014= N	029= 2	044= #	059= BACK	074= ⏻
015= O	030= 3	045= \leftrightarrow	060= LINE	

Font Size

PSE M16 / M19 / M24 / M30

Individual characters:	Height: 5 mm; font: Helvetica normal DIN1451-1E
Lettering, max. 3 characters:	Height: 3 mm; font: Helvetica normal DIN1451-1E
Symbols (Indices 037-052):	Height of capital letters: 5 mm; font: True Type, Symbol

PSE M22

Individual characters:	Height: 5 mm; font: Helvetica normal DIN1451-1E
Lettering, max. 3 characters:	Height: 5 mm; font: Helvetica normal DIN1451-1E
Lettering, max. 6 characters:	Height: 2.5 mm; font: Helvetica condensed DIN1451-1E
Symbols (Indices 037-052):	Height of capital letters: 5 mm; font: True Type, Symbol

Laser Lettering

<u>Material</u>	<u>Colour</u>	
Stainless Steel:	Black	Filled letters
Aluminum natural:	Grey	Filled letters (only after customer approval)
Anodized Aluminum:	White	Filled letters

Changes that contribute to technical improvement are subject to alternations.							
Page	Date of issue	Author:	Date of change:	Changed by:	Change No.	Datasheet No.	Index
21 of 24	19.05.2008	SHO	23.08.11	SHO	10474	105.9524.200	f

4 PACKAGING

PSE Switches

M16		10 pieces per carton with inlay
M19		10 pieces per carton with inlay
M22		10 pieces per carton with inlay
M24 / M27 / M30 with Ring Illumination	Air-cushion bag 1 piece	10 pieces per carton

Nuts with sealing rings are packaged separately and are enclosed in the carton.



Changes that contribute to technical improvement are subject to alternations.							
Page	Date of issue	Author:	Date of change:	Changed by:	Change No.	Datasheet No.	Index
22 of 24	19.05.2008	SHO	23.08.11	SHO	10474	105.9524.200	f

5 QUALIFICATION TESTS

5.1 IP Protection Class

IP Protection Class IEC/DIN/EN 60529	front side	IP 67
IP Protection Class DIN 40050-9:1993 (High-pressure steam jet cleaning test)	front side	IP 69K
DIN EN 60068-2-30 Db (moist heat (air test with 55°C / 93% humidity))	front side / back side	

5.2 IK Protection Class

Tested centrally

IK Protection Class DIN EN 50102	IK 02
----------------------------------	-------

5.3 Salt-Spray Test

Salt-spray test according to DIN 50021- SS
24h, 48h and 96h test duration

After 8h, the start of corrosion may be discerned; after 96h, this corrosion has spread across large areas of the switch.

This surface corrosion may be removed under running water.

5.4 Hygienic Switches for Food Processing Equipment

The PSE switches meet the requirements for food processing equipment:

DGUV test certificate FW 11 040

As housing material, stainless steel is recommended for use in food processing equipment.
At the final equipment, the installation position for switches with anodized aluminum housing may not be located above the food area.

Changes that contribute to technical improvement are subject to alternations.							
Page	Date of issue	Author:	Date of change:	Changed by:	Change No.	Datasheet No.	Index
23 of 24	19.05.2008	SHO	23.08.11	SHO	10474	105.9524.200	f

6 APPROVALS

Test	Norm
Thermal Shock	MIL-STD 202F Method 107G
High Temperature	MIL-STD 810E Method 501.3
Low Temperature	MIL-STD 810E Method 502.3
Humidity	MIL-STD 810E Method 507.3
Vibration	MIL-STD 202F Method 204D
Mechanical Shock	MIL-STD 202F Method 213B
RFI	MIL-STD 416D Method RS103
ESD	EN 61000-4-2 (+/- 6 kV Kontakt, +/- 16 kV Luft)
Burst	EN 61000-4-4 (+/- 1kV einzeln, +/- 2kV parallel)
Surge	EN 61000-4-5 (+/- 1kV unsym. , +/- 0,5kV sym.)

7 COMPLIANCE

All articles are ROHS-compliant and in compliance to the EMV - Directive (2004/108/EWG).



Changes that contribute to technical improvement are subject to alternations.							
Page	Date of issue	Author:	Date of change:	Changed by:	Change No.	Datasheet No.	Index
24 of 24	19.05.2008	SHO	23.08.11	SHO	10474	105.9524.200	f

Mouser Electronics

Authorized Distributor

Click to View Pricing, Inventory, Delivery & Lifecycle Information:

Schurter:

[1241.3075](#) [1241.3078](#) [1241.3086.7](#) [1241.3087](#) [1241.3098](#) [1241.3099](#) [1241.3101](#) [1241.3108](#) [1241.3111](#)
[1241.3123](#) [1241.3267](#) [1241.3268](#) [1241.3312](#) [1241.3315](#) [1241.3318](#) [1241.3406](#) [1241.3406.001](#) [1241.3406.028](#)
[1241.3406.029](#) [1241.3406.030](#) [1241.3406.031](#) [1241.3406.032](#) [1241.3406.033](#) [1241.3406.034](#) [1241.3407](#)
[1241.3427](#) [1241.3428](#) [1241.3442](#) [1241.31](#) [1241.327](#)



Компания «ЭлектроПласт» предлагает заключение долгосрочных отношений при поставках импортных электронных компонентов на взаимовыгодных условиях!

Наши преимущества:

- Оперативные поставки широкого спектра электронных компонентов отечественного и импортного производства напрямую от производителей и с крупнейших мировых складов;
- Поставка более 17-ти миллионов наименований электронных компонентов;
- Поставка сложных, дефицитных, либо снятых с производства позиций;
- Оперативные сроки поставки под заказ (от 5 рабочих дней);
- Экспресс доставка в любую точку России;
- Техническая поддержка проекта, помощь в подборе аналогов, поставка прототипов;
- Система менеджмента качества сертифицирована по Международному стандарту ISO 9001;
- Лицензия ФСБ на осуществление работ с использованием сведений, составляющих государственную тайну;
- Поставка специализированных компонентов (Xilinx, Altera, Analog Devices, Intersil, Interpoint, Microsemi, Aeroflex, Peregrine, Syfer, Eurofarad, Texas Instrument, Miteq, Cobham, E2V, MA-COM, Hittite, Mini-Circuits, General Dynamics и др.);

Помимо этого, одним из направлений компании «ЭлектроПласт» является направление «Источники питания». Мы предлагаем Вам помощь Конструкторского отдела:

- Подбор оптимального решения, техническое обоснование при выборе компонента;
- Подбор аналогов;
- Консультации по применению компонента;
- Поставка образцов и прототипов;
- Техническая поддержка проекта;
- Защита от снятия компонента с производства.



Как с нами связаться

Телефон: 8 (812) 309 58 32 (многоканальный)

Факс: 8 (812) 320-02-42

Электронная почта: org@eplast1.ru

Адрес: 198099, г. Санкт-Петербург, ул. Калинина, дом 2, корпус 4, литера А.