

Features

- Bushing mount
- Optional ± 0.05 linearity option
- Excellent wiper stability
- High stop strength
- Sealable
- RoHS compliant*

BOURNS®

3400 - Precision Potentiometer

Electrical Characteristics¹

Standard Resistance Range.....	100 to 500 K ohms
Total Resistance Tolerance.....	$\pm 3\%$
Independent Linearity.....	$\pm 0.15\%$
Effective Electrical Angle.....	$3600^\circ + 4^\circ, -0^\circ$
Absolute Minimum Resistance.....	1 ohm or 0.15 % maximum (whichever is greater)
Noise.....	100 ohms ENR maximum
Dielectric Withstanding Voltage.....	MIL-STD-202, Method 301
Sea Level.....	1,000 VAC minimum
80,000 Feet.....	300 VAC minimum
Power Rating (Voltage Limited By Power Dissipation, or 1,000 VAC, Whichever Is Less).....	(40 °C) 5 watts (125 °C) 0 watt
Insulation Resistance (500 VDC).....	1,000 megohms minimum
Resolution.....	See recommended part number

Environmental Characteristics¹

Operating Temperature Range.....	+1 °C to +125 °C
Storage Temperature Range.....	-65 °C to +125 °C
Temperature Coefficient Over Storage Temperature Range ²	± 20 ppm/°C maximum/unit
Vibration.....	10 G
Wiper Bounce.....	0.1 millisecond maximum
Total Resistance Shift.....	$\pm 2\%$ maximum
Voltage Ratio Shift.....	$\pm 0.1\%$ maximum
Shock.....	50 G
Wiper Bounce.....	0.1 millisecond maximum
Total Resistance Shift.....	$\pm 2\%$ maximum
Voltage Ratio Shift.....	$\pm 0.1\%$ maximum
Load Life.....	1,000 hours, 5 watts
Total Resistance Shift.....	$\pm 2\%$ maximum
Rotational Life (No Load).....	2,000,000 shaft revolutions ²
Total Resistance Shift.....	$\pm 5\%$ maximum
Moisture Resistance (MIL-STD-202, Method 103, Condition B)	
Total Resistance Shift.....	$\pm 2\%$ maximum
IP Rating.....	IP 40

Mechanical Characteristics¹

Stop Strength.....	53 N-cm (75 oz.-in.) min.
Mechanical Angle.....	$1080^\circ + 10^\circ, -0^\circ$ (3543); $1800^\circ + 10^\circ, -0^\circ$ (3545)
Torque (Starting & Running).....	0.35 N-cm (0.5 oz.-in.) max.
Mounting.....	170-200 N-cm (15-18 lb.-in.)
Shaft Runout.....	0.08 mm (0.003 in.) T.I.R.
Lateral Runout.....	0.13 mm (0.005 in.) T.I.R.
Shaft End Play.....	0.25 mm (0.010 in.) T.I.R.
Shaft Radial Play.....	0.08 mm (0.003 in.) T.I.R.
Pilot Diameter Runout.....	0.08 mm (0.003 in.) T.I.R.
Backlash.....	1.0 ° maximum
Weight.....	Approximately 21 gm
Terminals.....	Gold-plated solder lugs
Soldering Condition	
Manual Soldering.....	96.5Sn/3.0Ag/0.5Cu solid wire or no-clean rosin cored wire; 370 °C (700 °F) max. for 3 seconds
Wave Soldering.....	96.5Sn/3.0Ag/0.5Cu solder with no-clean flux; 260 °C (500 °F) max. for 5 seconds
Wash processes.....	Not recommended
Marking.....	Manufacturer's name and part number, resistance value and tolerance, linearity tolerance, wiring diagram, and date code.
Ganging (Multiple Section Pots.).....	2 cups maximum
Hardware.....	One lockwasher (H-37-2) and one mounting nut (H-38-2) is shipped with each potentiometer.

- 1 At room ambient: +25 °C nominal and 50 % relative humidity nominal, except as noted.
- 2 Consult manufacturer for complete specification details for resistances below 500 ohms and above 100K ohms.

Recommended Part Numbers

Part Number	Resistance (Ω)	Resolution (%)
3400S-1-102L	1,000	.020
3400S-1-502L	5,000	.013
3400S-1-103L	10,000	.010

BOLDFACE LISTINGS ARE IN STOCK AND READILY AVAILABLE THROUGH DISTRIBUTION.

FOR OTHER OPTIONS CONSULT FACTORY.

ROHS IDENTIFIER:
L = COMPLIANT

Product Dimensions

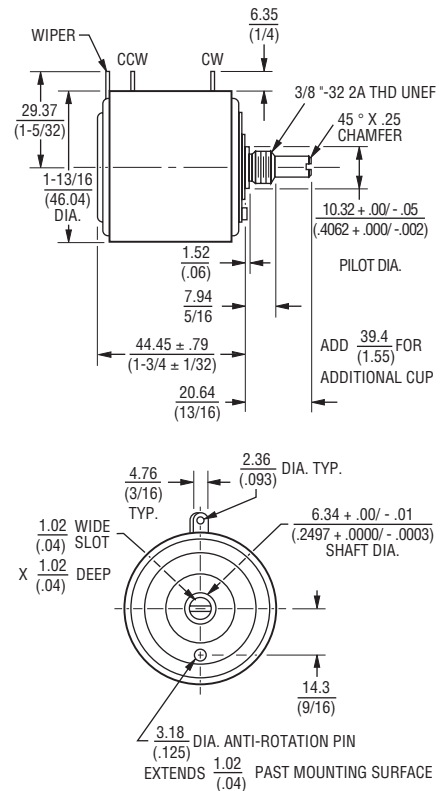

RECOMMENDED PANEL LAYOUT

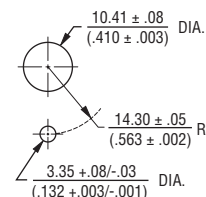

RECOMMENDED PCB THICKNESS: $\frac{2.46}{.097}$
MOUNTING TORQUE: 15-18 LB.-IN.

TOLERANCES: EXCEPT WHERE NOTED
DECIMALS: XX $\pm \frac{.25}{(.010)}$, XXX $\pm \frac{.13}{(.005)}$
FRACTIONS: $\pm 1/64$
DIMENSIONS: $\frac{MM}{(IN.)}$

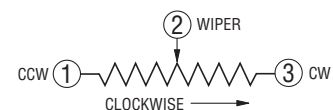

*RoHS Directive 2002/95/EC Jan. 27, 2003 including annex and
RoHS Recast 2011/65/EU June 8, 2011.

Specifications are subject to change without notice.

Customers should verify actual device performance in their specific applications.

3400 - Precision Potentiometer

BOURNS®

Panel Thickness Dimensions

(For Bushing Mount Only)

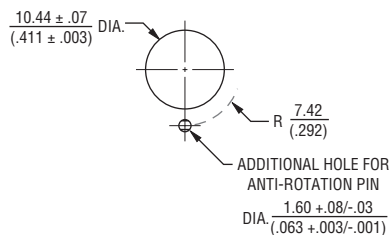
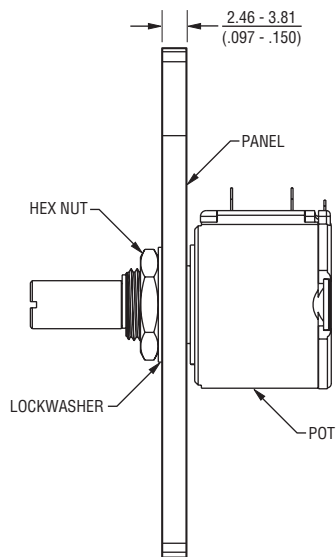

Anti-rotation pin hole is shown at six o'clock position for reference only. The actual location is determined by the customer's application. Refer to the front view of the potentiometer to see the location of the optional A/R pin.

Panel thickness and hole diameters are recommended for best fit. However, customers may adjust the dimensions to suit their specific application.



Компания «ЭлектроПласт» предлагает заключение долгосрочных отношений при поставках импортных электронных компонентов на взаимовыгодных условиях!

Наши преимущества:

- Оперативные поставки широкого спектра электронных компонентов отечественного и импортного производства напрямую от производителей и с крупнейших мировых складов;
- Поставка более 17-ти миллионов наименований электронных компонентов;
- Поставка сложных, дефицитных, либо снятых с производства позиций;
- Оперативные сроки поставки под заказ (от 5 рабочих дней);
- Экспресс доставка в любую точку России;
- Техническая поддержка проекта, помощь в подборе аналогов, поставка прототипов;
- Система менеджмента качества сертифицирована по Международному стандарту ISO 9001;
- Лицензия ФСБ на осуществление работ с использованием сведений, составляющих государственную тайну;
- Поставка специализированных компонентов (Xilinx, Altera, Analog Devices, Intersil, Interpoint, Microsemi, Aeroflex, Peregrine, Syfer, Eurofarad, Texas Instrument, Miteq, Cobham, E2V, MA-COM, Hittite, Mini-Circuits, General Dynamics и др.);

Помимо этого, одним из направлений компании «ЭлектроПласт» является направление «Источники питания». Мы предлагаем Вам помощь Конструкторского отдела:

- Подбор оптимального решения, техническое обоснование при выборе компонента;
- Подбор аналогов;
- Консультации по применению компонента;
- Поставка образцов и прототипов;
- Техническая поддержка проекта;
- Защита от снятия компонента с производства.



Как с нами связаться

Телефон: 8 (812) 309 58 32 (многоканальный)

Факс: 8 (812) 320-02-42

Электронная почта: org@eplast1.ru

Адрес: 198099, г. Санкт-Петербург, ул. Калинина, дом 2, корпус 4, литера А.