



Agilent ABA-52563 3.5 GHz Broadband Silicon RFIC Amplifier Data Sheet

Description

Agilent's ABA-52563 is an economical, easy-to-use, internally 50-ohm matched silicon monolithic amplifier that offers excellent gain and flat broadband response from DC to 3.5 GHz. Packaged in an ultraminiature industry-standard SOT-363 package, it requires half the board space of a SOT-143 package.

At 2 GHz, the ABA-52563 offers a small-signal gain of 21.5 dB, output P1dB of 9.8 dBm and 19.9 dBm output third order intercept point. It is suitable for use as buffer amplifiers for wideband applications. They are designed for low cost gain blocks in cellular applications, DBS tuners, LNB and other wireless communications systems.

ABA-52563 is fabricated using Agilent's HP25 silicon bipolar process, which employs a double-diffused single polysilicon process with self-aligned submicron emitter geometry. The process is capable of simultaneous high f_T and high NPN breakdown (25 GHz f_T at 6V BVCEO). The process utilizes industry standard device oxide isolation technologies and submicron aluminum multilayer interconnect to achieve superior performance, high uniformity, and proven reliability.

Surface Mount Package SOT-363 / SC70



Pin Connections and Package Marking

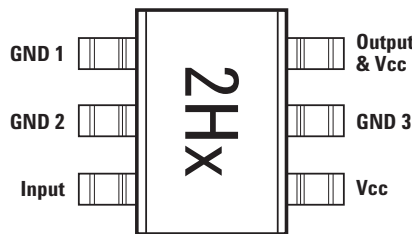

Note:
Top View. Package marking provides orientation and identification. "x" is character to identify date code.

Simplified Schematic

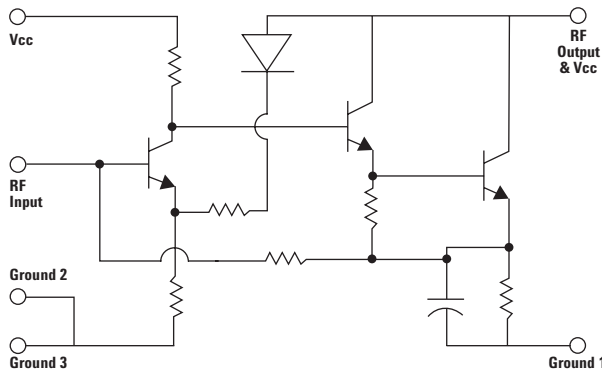

Features

- Operating frequency: DC ~ 3.5 GHz
- 21.5 dB gain
- VSWR < 2.0 throughout operating frequency
- 9.8 dBm output P1dB
- 3.3 dB noise figure
- Unconditionally stable
- Single 5V supply ($I_d = 35$ mA)
- Lead-free option available

Applications

- Amplifier for cellular, cordless, special mobile radio, PCS, ISM, wireless LAN, DBS, TVRO, and TV tuner applications



ABA-52563 Absolute Maximum Ratings^[1]

Symbol	Parameter	Units	Absolute Max.
V_{cc}	Device Voltage, RF output to ground (T = 25°C)	V	+7
P_{in}	CW RF Input Power (V _{cc} = 5V)	dBm	+20
P_{diss}	Total Power Dissipation ^[3]	W	0.4
T_j	Junction Temperature	°C	150
T_{STG}	Storage Temperature	°C	-65 to 150

Thermal Resistance^[2] (V_{cc} = 5V):

$$\theta_{jc} = 106^\circ\text{C/W}$$

Notes:

1. Operation of this device in excess of any of these limits may cause permanent damage.
2. Thermal resistance measured using 150°C Liquid Crystal Measurement Technique.
3. Board (package belly) temperature, T_b, is 25°C. Derate 3.5 mW/°C for T_b > 109°C.

Electrical Specifications

T_c = +25°C, Z₀ = 50 Ω, P_{in} = -30 dBm, V_{cc} = 5V, Freq = 2 GHz, unless stated otherwise.

Symbol	Parameter and Test Condition	Units	Min.	Typ.	Max.	Std Dev.
G _p ^[1]	Power Gain ($ S_{21} ^2$)	dB	20	21.5		0.2
ΔG _p	Power Gain Flatness, f = 0.1 ~ 2.5 GHz f = 0.1 ~ 3.5 GHz	dB		0.5 2.1		
NF ^[1]	Noise Figure	dB		3.3	4	0.12
P1dB ^[1]	Output Power at 1dB Gain Compression	dBm		9.8		0.15
OIP3 ^[1]	Output Third Order Intercept Point	dBm		19.9		0.18
VSWR _{in} ^[1]	Input VSWR			1.2		
VSWR _{out} ^[1]	Output VSWR			1.4		
I _{cc} ^[1]	Device Current	mA		35	43	0.5
t _d ^[1]	Group Delay	ps		150		

Notes:

1. Measurements taken on 50Ω test board shown on Figure 1. Excess circuit losses had been de-embedded from actual measurements. Standard deviation and typical data based on at least 500 parts sample size from 6 wafer lots. Future wafers allocated to this product may have nominal values anywhere within the upper and lower spec limits.

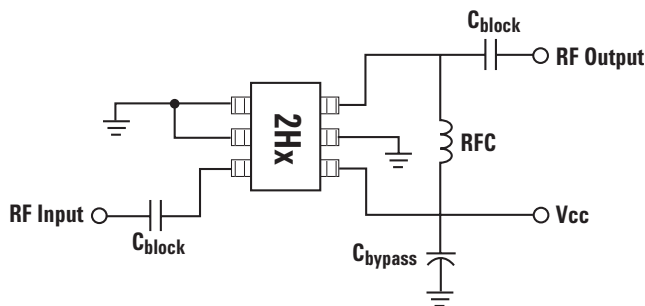

Figure 1. ABA-52563 Production Test Circuit.

ABA-52563 Typical Performance

$T_c = +25^\circ\text{C}$, $Z_o = 50\Omega$, $V_{cc} = 5\text{V}$ unless stated otherwise.

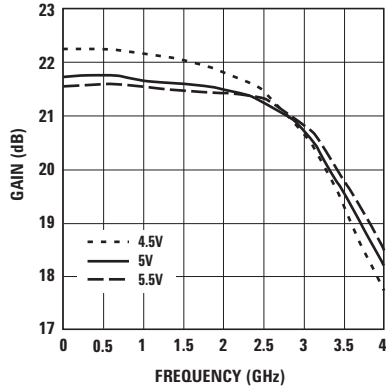

Figure 2. Gain vs. Frequency and Voltage.

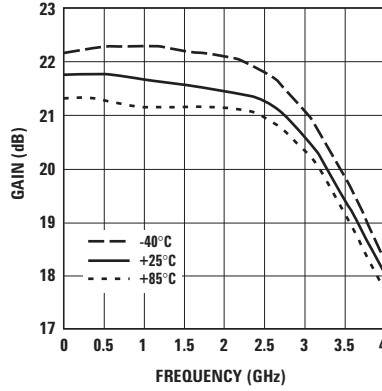

Figure 3. Gain vs. Frequency and Temperature.

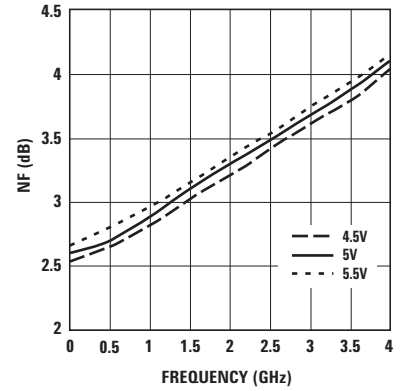

Figure 4. Noise Figure vs. Frequency and Voltage.

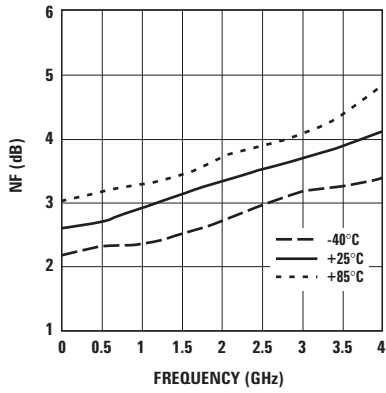

Figure 5. Noise Figure vs. Frequency and Temperature.

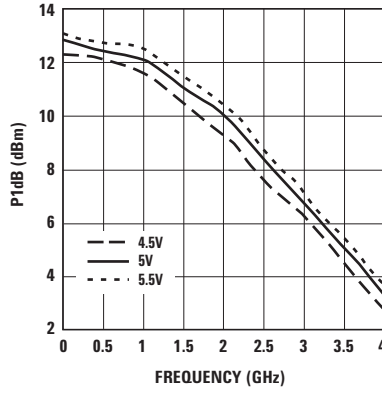

Figure 6. Output Power for 1 dB Gain Compression vs. Frequency and Voltage.

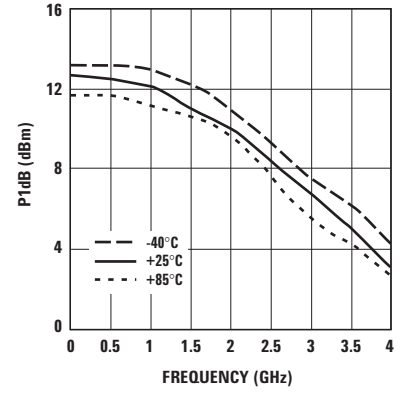

Figure 7. Output Power for 1 dB Gain Compression vs. Frequency and Temperature.

ABA-52563 Typical Performance, continued

$T_c = +25^\circ\text{C}$, $Z_o = 50\Omega$, $V_{cc} = 5\text{V}$ unless stated otherwise.

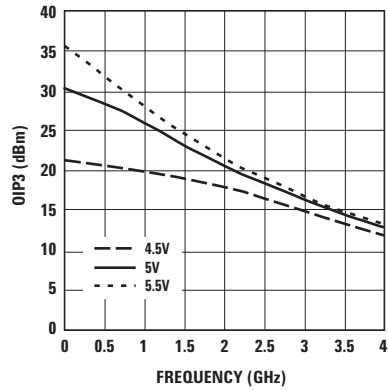

Figure 8. Output IP3 vs. Frequency and Voltage.

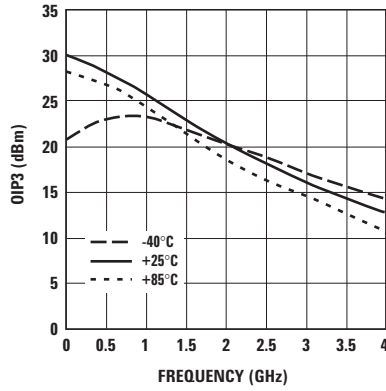

Figure 9. Output IP3 vs. Frequency and Temperature.

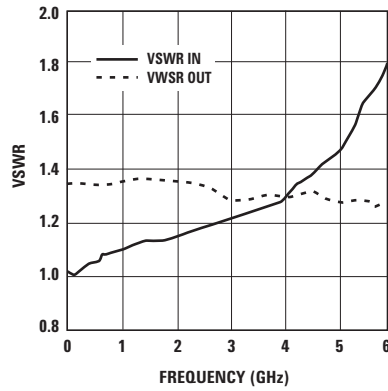

Figure 10. Input and Output VSWR vs. Frequency.

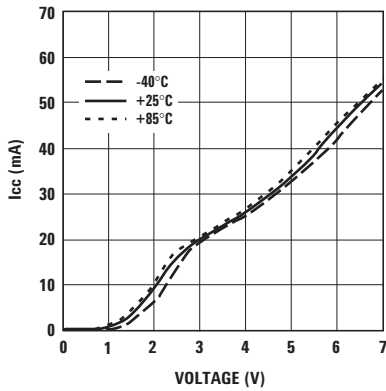

Figure 11. Supply Current vs. Voltage and Temperature.

ABA-52563 Typical Scattering Parameters

T_C = +25°C, V_{CC} = 5V, Z₀ = 50 Ω, unless stated otherwise

Freq (GHz)	S ₁₁ Mag.	S ₁₁ Ang.	S ₂₁ dB	S ₂₁ Mag.	S ₂₁ Ang.	S ₁₂ dB	S ₁₂ Mag.	S ₁₂ Ang.	S ₂₂ Mag.	S ₂₂ Ang.	K Factor
0.05	0.01	146.6	21.7	12.10	-2.6	-30.2	0.03	0.3	0.15	-2.4	1.492
0.10	0.00	134.0	21.7	12.11	-4.8	-30.5	0.03	-0.3	0.15	-5.1	1.528
0.20	0.00	-40.6	21.7	12.16	-9.6	-30.5	0.03	0.1	0.15	-9.6	1.523
0.30	0.01	-53.2	21.7	12.19	-14.5	-30.8	0.03	1.2	0.15	-13.0	1.560
0.40	0.02	-56.7	21.7	12.19	-19.5	-30.8	0.03	2.4	0.14	-15.7	1.560
0.50	0.03	-141.5	21.8	12.26	-24.8	-30.5	0.03	1.0	0.15	-15.7	1.516
0.60	0.03	-128.1	21.8	12.24	-29.8	-30.8	0.03	3.1	0.15	-17.6	1.557
0.70	0.04	-127.5	21.7	12.21	-34.9	-30.5	0.03	4.3	0.15	-20.3	1.520
0.80	0.04	-126.7	21.7	12.18	-39.8	-30.5	0.03	6.1	0.15	-22.5	1.523
0.90	0.05	-123.9	21.7	12.16	-44.7	-30.8	0.03	7.4	0.15	-24.2	1.563
1.00	0.05	-125.0	21.7	12.13	-49.7	-30.8	0.03	11.7	0.15	-26.4	1.566
1.20	0.05	-123.4	21.7	12.10	-59.6	-30.2	0.03	10.8	0.15	-29.4	1.490
1.40	0.06	-127.4	21.6	12.05	-69.4	-30.2	0.03	12.4	0.15	-32.4	1.491
1.60	0.06	-133.8	21.6	12.04	-79.6	-29.6	0.03	13.0	0.15	-35.3	1.424
1.80	0.06	-136.7	21.6	12.00	-89.8	-29.1	0.04	14.7	0.15	-37.8	1.370
2.00	0.07	-142.5	21.5	11.94	-100.4	-29.4	0.03	14.3	0.15	-38.3	1.402
2.20	0.07	-143.9	21.5	11.87	-111.2	-28.6	0.04	16.7	0.15	-37.8	1.326
2.40	0.08	-146.1	21.4	11.75	-121.9	-28.4	0.04	16.2	0.15	-37.3	1.309
2.60	0.09	-148.4	21.3	11.56	-133.2	-28.0	0.04	17.3	0.14	-36.9	1.279
2.80	0.09	-149.5	21.1	11.33	-144.5	-27.7	0.04	15.6	0.14	-36.4	1.273
3.00	0.10	-152.7	20.8	10.95	-156.1	-27.3	0.04	15.8	0.13	-35.9	1.263
3.20	0.10	-158.7	20.4	10.51	-167.5	-27.1	0.04	15.6	0.13	-35.4	1.275
3.40	0.11	-163.2	20.0	9.97	-178.7	-27.3	0.04	15.5	0.13	-34.9	1.338
3.50	0.11	-167.6	19.7	9.67	175.9	-26.6	0.05	16.0	0.13	-34.6	1.285
4.00	0.12	165.9	18.3	8.25	150.6	-.26.2	0.05	12.0	0.13	-33.4	1.386
4.50	0.16	138.3	16.9	6.98	126.3	-25.5	0.05	12.7	0.14	-37.1	1.462
5.00	0.19	122.8	15.1	5.71	105.0	-24.7	0.06	9.5	0.12	-48.4	1.585
5.50	0.25	112.3	13.7	4.85	86.7	-23.5	0.07	6.0	0.12	-63.0	1.565
6.00	0.30	99.3	12.3	4.14	70.4	-23.1	0.07	1.0	0.11	-83.5	1.680

Device Models

Refer to Agilent's web site
www.agilent.com/view/rf

Ordering Information

Part Number	Devices per Container	Container
ABA-52563-TR1	3000	7" reel
ABA-52563-TR2	10000	13" reel
ABA-52563-BLK	100	antistatic bag
ABA-52563-TR1G	3000	7" reel
ABA-52563-TR2G	10000	13" reel
ABA-52563-BLKG	100	antistatic bag

Note: For lead-free option, the part number will have the character "G" at the end.

Package Dimensions

Outline 63 (SOT-363/SC-70)

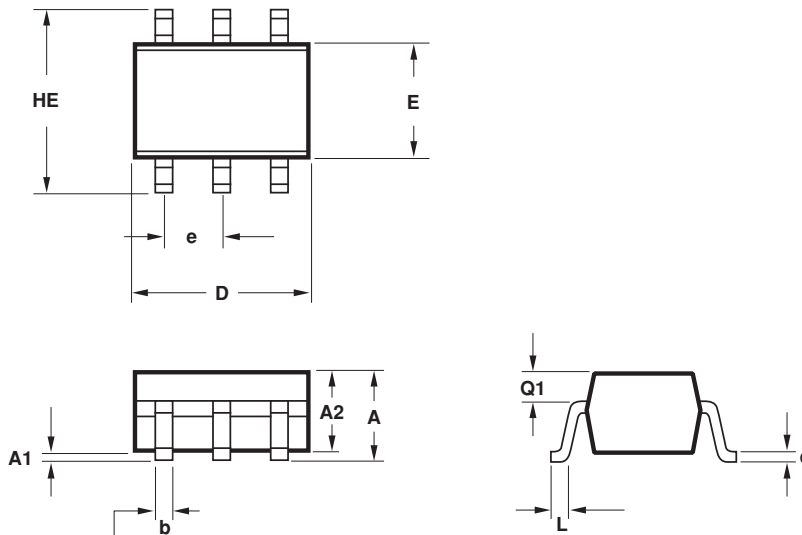

SYMBOL	DIMENSIONS (mm)	
	MIN.	MAX.
E	1.15	1.35
D	1.80	2.25
HE	1.80	2.40
A	0.80	1.10
A2	0.80	1.00
A1	0.00	0.10
Q1	0.10	0.40
e	0.650 BCS	
b	0.15	0.30
c	0.10	0.20
L	0.10	0.30

NOTES:

- All dimensions are in mm.
- Dimensions are inclusive of plating.
- Dimensions are exclusive of mold flash & metal burr.
- All specifications comply to EIAJ SC70.
- Die is facing up for mold and facing down for trim/form, ie: reverse trim/form.
- Package surface to be mirror finish.

Recommended PCB Pad Layout for Agilent's SC70 6L/SOT-363 Products

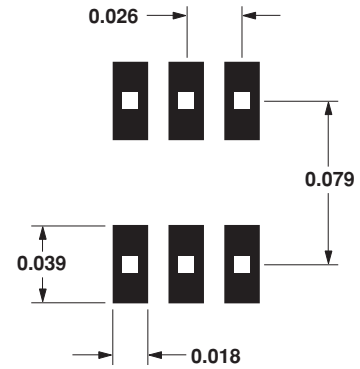

Dimensions in inches.

Device Orientation

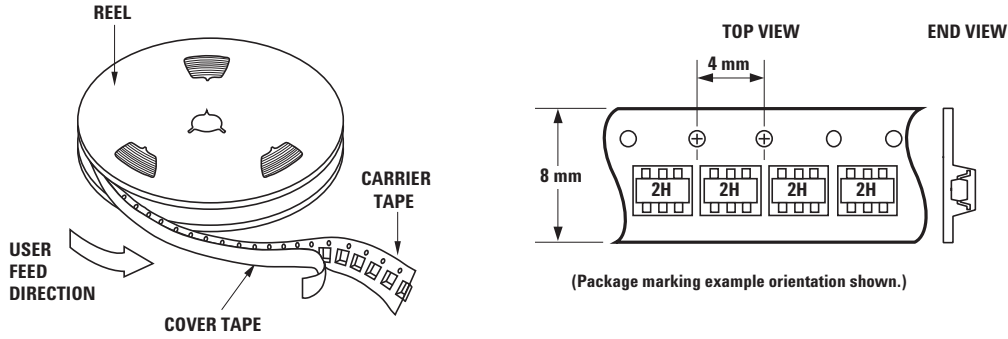

Tape Dimensions and Product Orientation for Outline 63

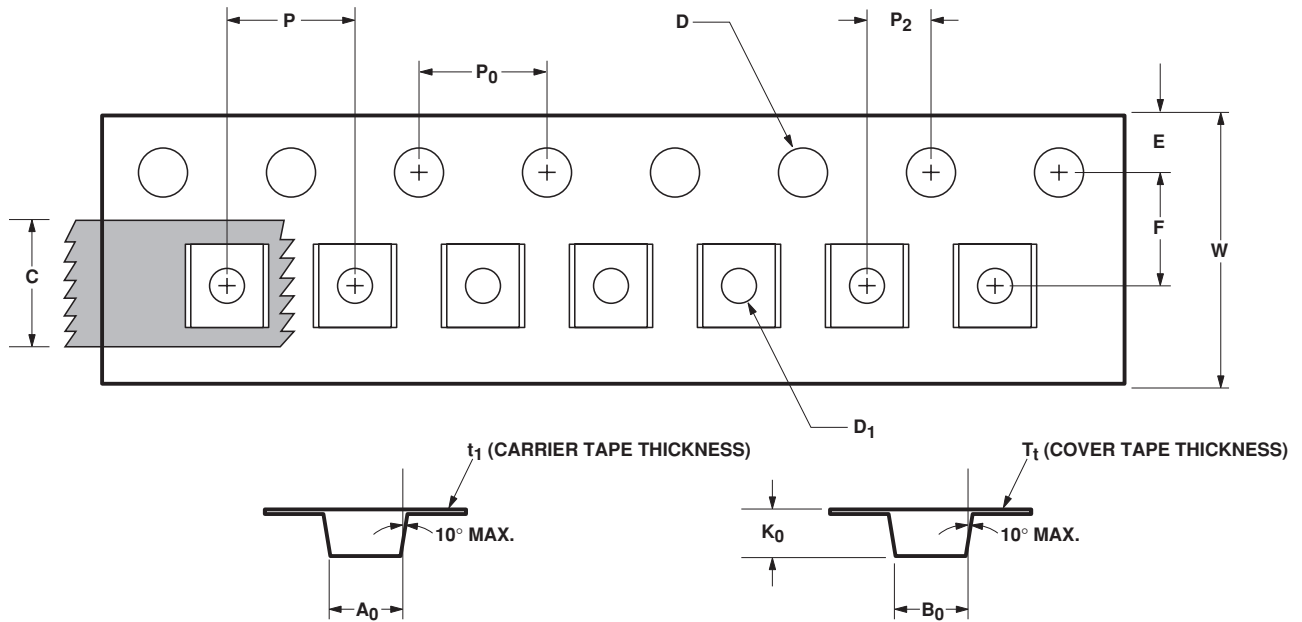

DESCRIPTION		SYMBOL	SIZE (mm)	SIZE (INCHES)
CAVITY	LENGTH	A ₀	2.40 ± 0.10	0.094 ± 0.004
	WIDTH	B ₀	2.40 ± 0.10	0.094 ± 0.004
	DEPTH	K ₀	1.20 ± 0.10	0.047 ± 0.004
	PITCH	P	4.00 ± 0.10	0.157 ± 0.004
	BOTTOM HOLE DIAMETER	D ₁	1.00 + 0.25	0.039 + 0.010
PERFORATION	DIAMETER	D	1.50 ± 0.10	0.061 + 0.002
	PITCH	P ₀	4.00 ± 0.10	0.157 ± 0.004
	POSITION	E	1.75 ± 0.10	0.069 ± 0.004
CARRIER TAPE	WIDTH	W	8.00 + 0.30 - 0.10	0.315 + 0.012
	THICKNESS	t ₁	0.254 ± 0.02	0.0100 ± 0.0008
COVER TAPE	WIDTH	C	5.40 ± 0.10	0.205 + 0.004
	TAPE THICKNESS	T _t	0.062 ± 0.001	0.0025 ± 0.0004
DISTANCE	CAVITY TO PERFORATION (WIDTH DIRECTION)	F	3.50 ± 0.05	0.138 ± 0.002
	CAVITY TO PERFORATION (LENGTH DIRECTION)	P ₂	2.00 ± 0.05	0.079 ± 0.002

www.agilent.com/semiconductors

For product information and a complete list of distributors, please go to our web site.

For technical assistance call:

Americas/Canada: +1 (800) 235-0312 or
(916) 788-6763

Europe: +49 (0) 6441 92460

China: 10800 650 0017

Hong Kong: (65) 6756 2394

India, Australia, New Zealand: (65) 6755 1939

Japan: (+81 3) 3335-8152(Domestic/International), or
0120-61-1280(Domestic Only)

Korea: (65) 6755 1989

Singapore, Malaysia, Vietnam, Thailand, Philippines,
Indonesia: (65) 6755 2044

Taiwan: (65) 6755 1843

Data subject to change.

Copyright © 2004 Agilent Technologies, Inc.

Obsoletes 5989-0951EN

December 4, 2004

5989-1971EN



Agilent Technologies



Компания «ЭлектроПласт» предлагает заключение долгосрочных отношений при поставках импортных электронных компонентов на взаимовыгодных условиях!

Наши преимущества:

- Оперативные поставки широкого спектра электронных компонентов отечественного и импортного производства напрямую от производителей и с крупнейших мировых складов;
- Поставка более 17-ти миллионов наименований электронных компонентов;
- Поставка сложных, дефицитных, либо снятых с производства позиций;
- Оперативные сроки поставки под заказ (от 5 рабочих дней);
- Экспресс доставка в любую точку России;
- Техническая поддержка проекта, помощь в подборе аналогов, поставка прототипов;
- Система менеджмента качества сертифицирована по Международному стандарту ISO 9001;
- Лицензия ФСБ на осуществление работ с использованием сведений, составляющих государственную тайну;
- Поставка специализированных компонентов (Xilinx, Altera, Analog Devices, Intersil, Interpoint, Microsemi, Aeroflex, Peregrine, Syfer, Eurofarad, Texas Instrument, Miteq, Cobham, E2V, MA-COM, Hittite, Mini-Circuits, General Dynamics и др.);

Помимо этого, одним из направлений компании «ЭлектроПласт» является направление «Источники питания». Мы предлагаем Вам помощь Конструкторского отдела:

- Подбор оптимального решения, техническое обоснование при выборе компонента;
- Подбор аналогов;
- Консультации по применению компонента;
- Поставка образцов и прототипов;
- Техническая поддержка проекта;
- Защита от снятия компонента с производства.



Как с нами связаться

Телефон: 8 (812) 309 58 32 (многоканальный)

Факс: 8 (812) 320-02-42

Электронная почта: org@eplast1.ru

Адрес: 198099, г. Санкт-Петербург, ул. Калинина, дом 2, корпус 4, литера А.