



A New Direction in Mixed-Signal

May 2014

XRP7724/7725EVB-DEMO-2

Quad Channel Digital PWM/PFM Demo Board Programmable Power Management System

Rev. 1.0.0

GENERAL DESCRIPTION

The XRP7724/7725EVB-DEMO-2 board is a complete four channel power system. It is configured to provide 3.3V, 2.5V 1.5V and 1V at a maximum of 3A, 3A, 5A and 10A loads respectively. The 1.5V and 1V supplies can be adjusted in 2.5mV increments, the 2.5V supply in 5mV increments, and the 3.3V supply is adjustable in 10mV increments. The order and ramp rates for each supply can be programmed to accommodate any sequencing requirement. All power supply operations can be controlled over an I²C interface. Faults, output voltages and currents can also be monitored. Two GPIO and three PSIO signals are available and can be programmed to provide a variety of functions. Unused GPIO/PSIO pins can be programmed as I/O expansion for a microcontroller. The board is supported by PowerArchitect™ 5.1 or later and plugs directly onto the interposer board acting as an interface to an Arduino controller or Exar's XCM.

EVALUATION BOARD MANUAL

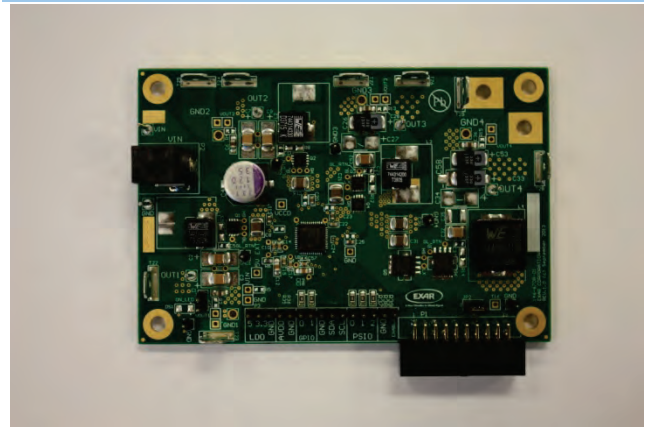

XRP7724/7725EVB-DEMO-2

FEATURES

- **XRP24/7725 Programmable Controller**
- **4 Channel Power System**
- **Wide Input Voltage Range: 5.5V-25V**
- **I²C Interface**
 - Programming
 - Remote re-configurability
 - Monitoring
 - Control
- **Arduino GPIO, PSIO and ENABLE control**



A New Direction in Mixed-Signal

May 2014

XRP7724/7725EVB-DEMO-2

Quad Channel Digital PWM/PFM Demo Board Programmable Power Management System

Rev. 1.0.0

EVALUATION BOARD SCHEMATICS

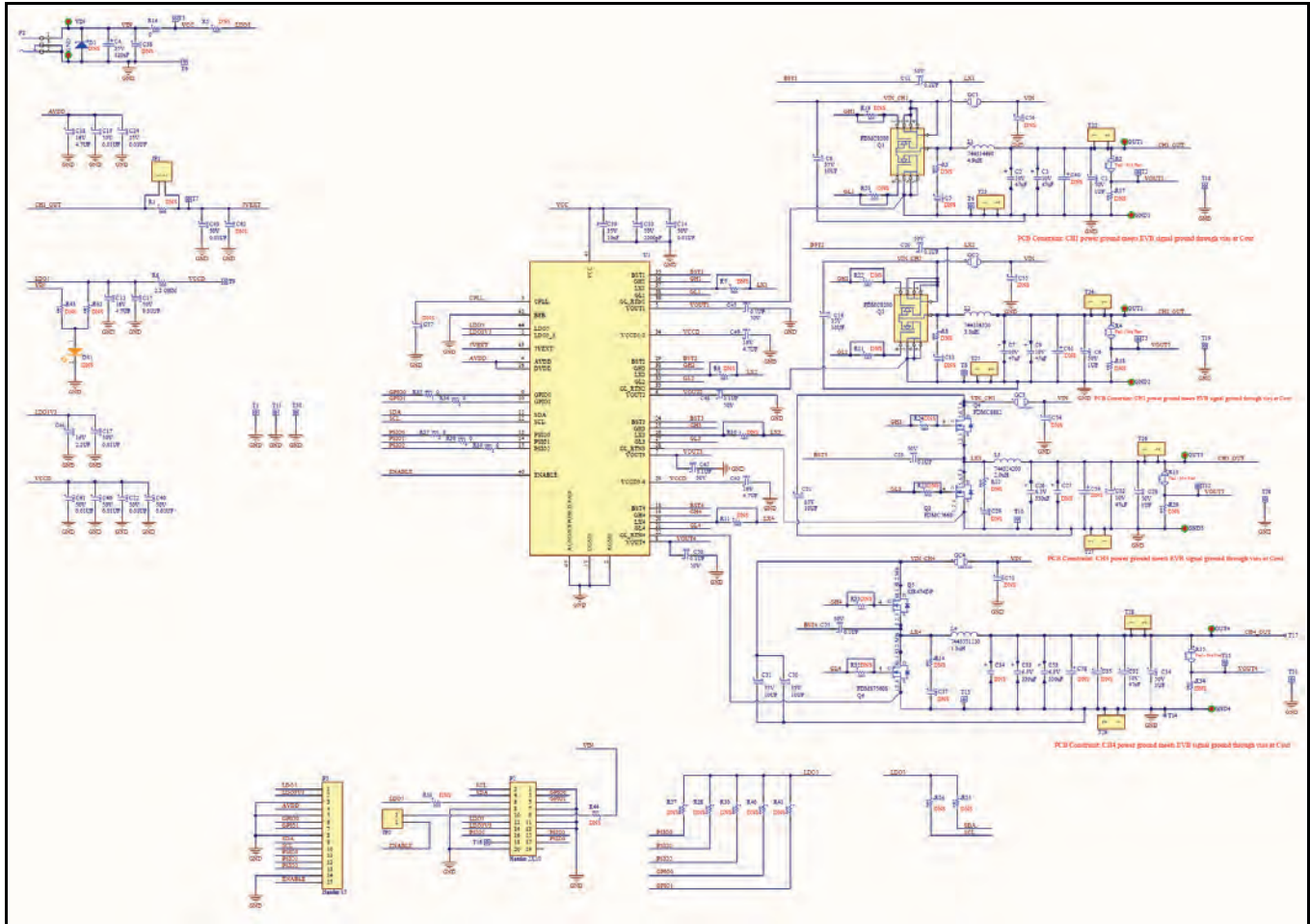

Figure 1 XRP7724/7725 Evaluation Board Schematics

PIN ASSIGNMENT

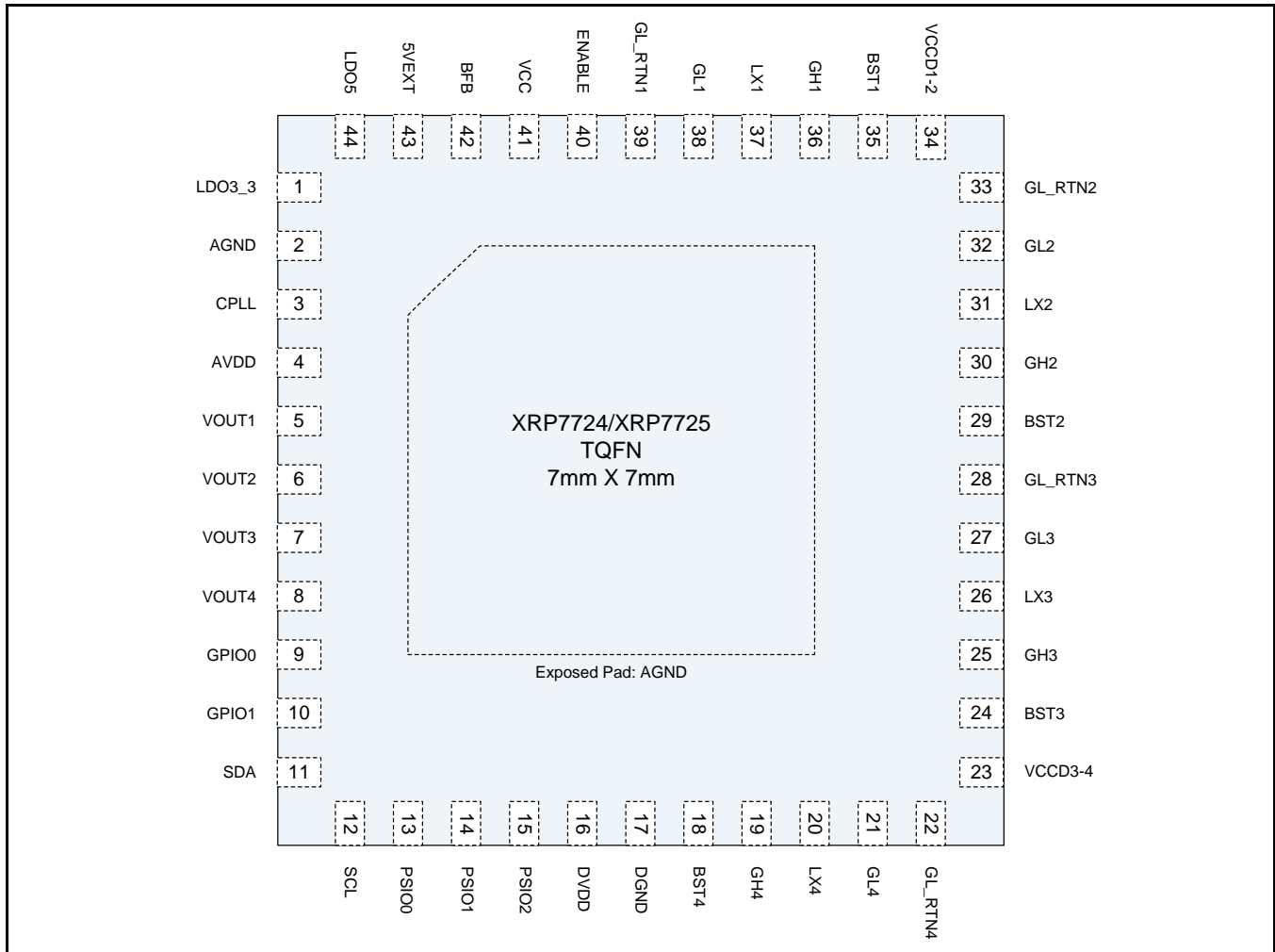

Figure 2 XRP7724/7725 Pin Assignment

PIN DESCRIPTION

Name	Pin Number	Description
VCC	41	Input voltage. Place a decoupling capacitor close to the pin. This input is used in UVLO fault generation.
DVDD	16	1.8V supply for digital circuitry. Connect pin to AVDD. Place a decoupling capacitor close to the pin.
VCCD1-2 VCCD3-4	23,34	Gate Drive supply. Two independent gate drive supply pins where pin 34 supplies drivers 1 and 2 and pin 23 supplies drivers 3 & 5. One of the two pins must be connected to the LDO5 pin to enable two power rails initially. It is recommended that the other VCCD pin be connected to the output of a 5V switching rail (for improved efficiency or for driving larger external FETs), if available, otherwise this pin may also be connected to the LDO5 pin. A bypass capacitor (>1uF) to PAD is recommended for each VCCD pin with the pin(s) connected to LDO5 with shortest possible etch.
AGND	2	Analog ground pin. This is the small signal ground connection.
GL_RTNA1-4	39,33, 28,22	Ground connection for the low side gate driver. This should be routed as a signal trace with GL. Connect to the source of the low side MOSFET.
GL1-GL4	38,32, 27,21	Output pin of the low side gate driver. Connect directly to the gate of an external N-channel MOSFET.



XRP7724/7725EVB-DEMO-2

Quad Channel Digital PWM/PFM Demo Board Programmable Power Management System

Name	Pin Number	Description
GH1-GH4	36,30, 25,19	Output pin of the high side gate driver. Connect directly to the gate of an external N-channel MOSFET.
LX1-LX4	37,31, 26,20	Lower supply rail for the GH high-side gate driver. Connect this pin to the switching node at the junction between the two external power MOSFETs and the inductor. These pins are also used to measure voltage drop across bottom MOSFETs in order to provide output current information to the control engine.
BST1-BST4	35,29, 24,18	High side driver supply pin(s). Connect BST to the external capacitor as shown in the Typical Application Circuit on page 5. The high side driver is connected between the BST pin and LX pin and delivers the BST pin voltage to the high side FET gate each cycle.
GPIO-GPIO1	9,10	These pins can be configured as inputs or outputs to implement custom flags, power good signals, enable/disable controls and synchronization to an external clock.
PSIO0-PSIO2	13,14,15	Open drain, these pins can be used to control external power MOSFETs to switch loads on and off, shedding the load for fine grained power management. They can also be configured as standard logic outputs or inputs just as any of the GPIOs can be configured, but as open drains require an external pull-up when configured as outputs.
SDA, SCL	11,12	SMBus/I ² C serial interface communication pins. These pins can be configured open drain or pseudo-TTL requiring a pull-up resistor.
VOUT1-VOUT4	5,6,7,8	Connect to the output of the corresponding power stage. The output is sampled at least once every switching cycle
LDO5	44	Output of a 5V LDO. This is a micro power LDO that can remain active while the rest of the IC is in the stand-by mode. This LDO is also used to power the internal Analog Blocks.
LDO3_3	1	Output of the 3.3V standby LDO. This is a micro power LDO that can remain active while the rest of the IC is in shutdown.
ENABLE	40	If ENABLE is pulled high or allowed to float high, the chip is powered up (logic is reset, registers configuration loaded, etc.). The pin must be held low for the XRP7724 to be placed into shutdown. Active channels will automatically be ramped down, if desired, prior to the disabling of the chip.
BFB	42	Input from the 15V output created by the external boost supply. When this pin goes below a pre-defined threshold, a pulse is created on the low side drive to charge this output back to the original level. If not used, this pin should be connected to GND.
DGND	17	Digital ground pin. This is the logic ground connection, and should be connected to the ground plane close to the PAD.
CPLL	3	PLL compensation capacitor

ORDERING INFORMATION

Part Number	Description
XRP7724EVB-DEMO-2	XRP7724EVB-DEMO-2 Evaluation Board
XRP7724EVB-DEMO-2-KIT	Evaluation kit includes XRP7724EVB-DEMO-2 Evaluation Board with Power Architect software and interface board
XRP7724EVB-DEMO-2-KITA	Evaluation kit includes XRP7724EVB-DEMO-2 Evaluation Board with Power Architect software, interface and Arduino controller boards
XRP7725EVB-DEMO-2	XRP7725EVB-DEMO-2 Evaluation Board
XRP7725EVB-DEMO-2-KIT	Evaluation kit includes XRP7725EVB-DEMO-2 Evaluation Board with Power Architect software and interface board
XRP7725EVB-DEMO-2-KITA	Evaluation kit includes XRP7725EVB-DEMO-2 Evaluation Board with Power Architect software, interface and Arduino controller boards
XR77EVB-INT-1	Interface board designed for use with an Arduino controller and compatible evaluation boards. Also has connectivity for the Exar Configuration Module (XCM)
XRP77XXEVB-XCM	Exar Configuration Module (XCM). USB to I2C interface board.

USING THE EVALUATION BOARD

INPUT VOLTAGE RANGE

The input voltage range of these boards is from 5.5V to 25V. The power components have been optimized for a 12V input rail. When running the board at an input voltage other than 12V, use PowerArchitect™ 5.1 to evaluate the system performance.

I²C INTERFACE

The XRP7724 and XRP7725 programmable power controllers employ a standard I²C interface. Although the I²C signals can be pulled up to LDO5 on board by means of installing resistors at the locations R25 and R26, the I²C bus signals are pulled up on the controller interface board (XR77EVB-INT-1) by default (refer to Appendix – jumpers installed shorting pins 2 and 3 together at the locations JP6 and JP7).

OPERATING THE EVALUATION BOARD

The XRP7724/7725EVB-DEMO-2 is designed to be powered from either an AC/DC wall wart (the output voltage must be in the range of the controllers - 5.5V to 25V) connected to the barrel connector or a test bench DC power supply (the voltage must be in the range of the controllers - 5.5V to 25V) connected to the V_{IN} connectors.

BRING UP PROCEDURE

Plug the XRP7724/7725EVB-DEMO-2 evaluation board and the Arduino board into the controller interface board as shown below.



Load the [latest](#) PowerArchitect™ 5 software and run it.

After selecting the proper family (Chips) and the device (XRP7724 or XRP7725), select the “Get Started with the EVB-DEMO2” option when prompted as shown below.

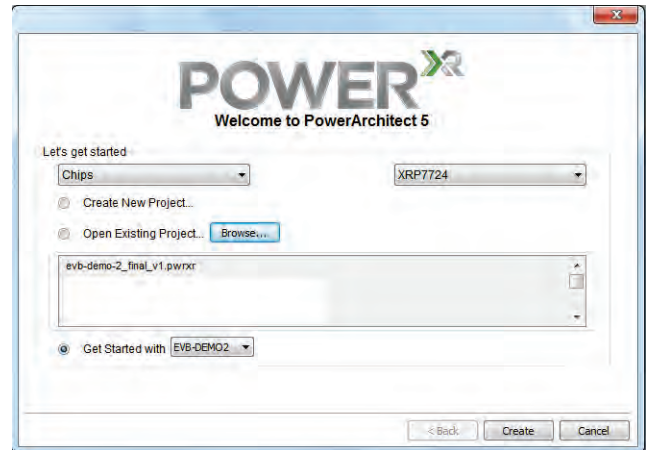

When done, click “Create”. PowerArchitect™ 5 will load the default configuration automatically.

Apply Power to the board. Please refer to the sections above on how to properly supply power to the board and what voltage range to use.

Turn on the Power supply.

Use USB cable to connect the computer (type A) and the Arduino controller board (type B).

Go to the Tools tab in PA 5 and select Boards. The software will identify communication ports where it found the Arduino controller board. Select the port.

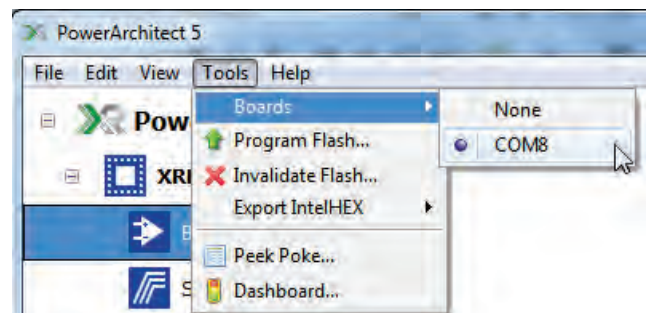

PA 5 is now communicating with the Arduino controller board which is indicated in the lower left corner.

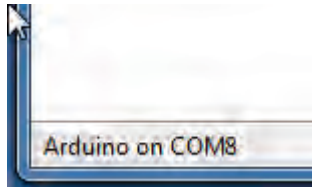

Programming the Configuration onto XRP7724/7725

To program a configuration go to the Tools tab in PA 5 and select Program Flash.

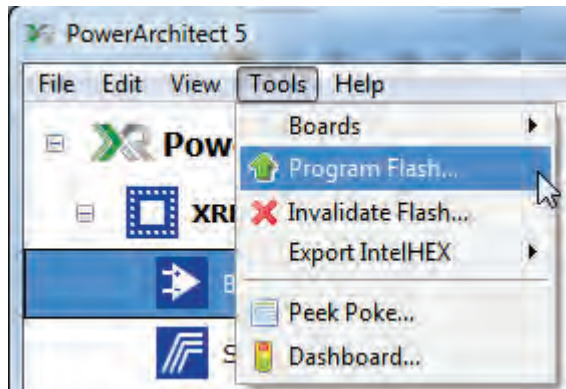

The program Flash window will appear.

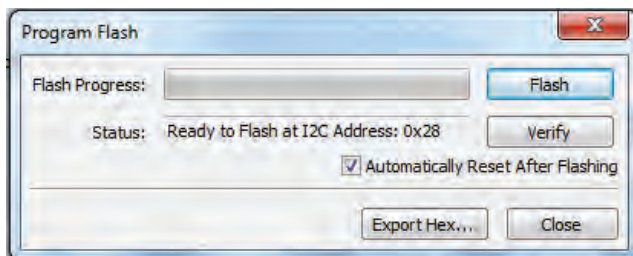

Click the Flash button.

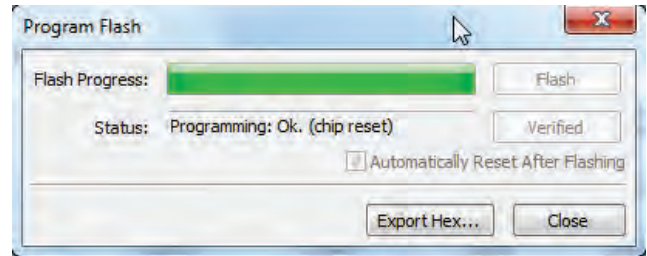

PA 5 will go through the process of loading configuration in the flash. Once it has successfully completed the task, it will report the outcome as seen above and reset the device if "Automatically Reset After Flashing" box checked (default option).

Close the window.

Note that XRP7724/7725EVb-DEMO-2 boards will be pre-loaded with the default configuration.

Regulation

To enable channel regulation go to the Tools tab in PA 5 and select Dashboard.

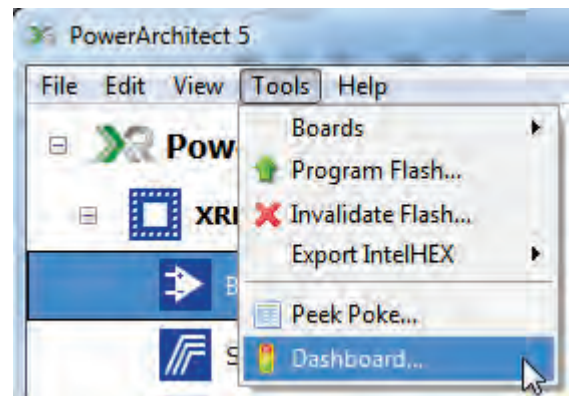

In Dashboard turn Group 1 and Group 2 on. The configuration groups the channels 1 and 2 into the group 1, and the channels 3 and 4 into the group 2. The channels are now in regulation as indicated by V_{OUT} readings as well as the in-regulation indicators.



desired. To do this, one will need to populate the locations R27, R28, R30.

EVALUATION BOARD CONNECTIONS

The following picture illustrates how V_{IN} supplied from a test bench DC power supply and instruments attached to the outputs would be connected to the XRP7724/7725EVB-DEMO-2 board.

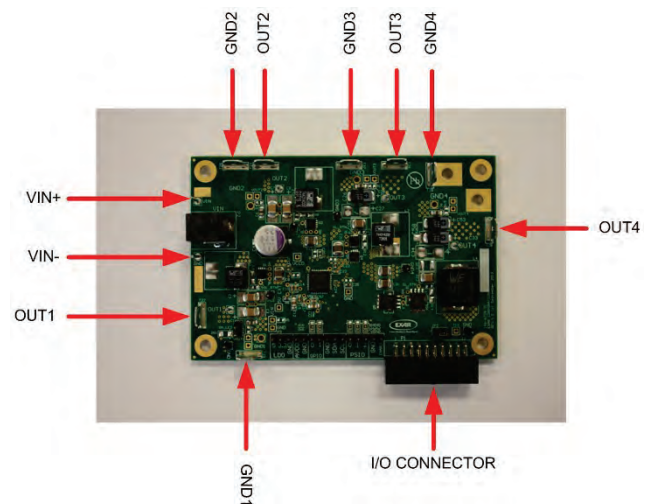

Channels can be turned on individually if desired.

GPIO and PISO interface

The GPIOs, PSIOs and ENABLE can be controlled from the Arduino controller dynamically in the dashboard.

ENABLE signal is connected to the Arduino controller board by default (JP2 header is shorted). Arduino drives the ENABLE pin low to place XRP7724/7725 into the shutdown mode. It releases the ENABLE pin to enable the device. If leaving the ENABLE pin floating is desired, the jumper at JP2 shall be removed.

The PSIOs are not pulled up on XRP7724/7725EVB-DEMO-2 by default. There is a loading option to pull PSIOs up to LDO5 if

INTERFACE BOARD CONNECTIONS

The following picture illustrates connections on the interface board - XR77EVB-INT-1. Its primary task is to provide interface between the Arduino controller board and EVB. In addition, as explained in the subsequent sections, it can be used to make connection between XCM and EVB using 10-wire ribbon cable.

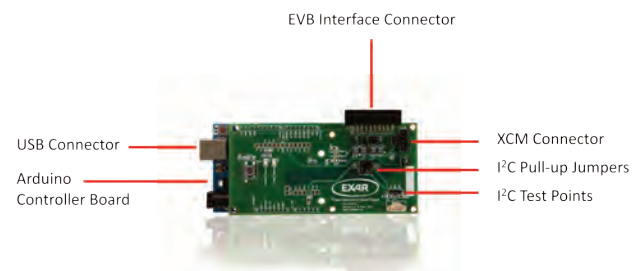

USING EXAR CONFIGURATION MODULE (XCM) TO COMMUNICATE WITH THE EVALUATION BOARD

It is possible to use the XCM (firmware version v62) to communicate with the XRP7724/7725EVB-DEMO-2 board. PA 5 supports XCM. The main task will be connecting XCM to the evaluation board.

Using Interface Board

If the interface board is available use following steps:

- Make sure no Arduino controller board is connected to the interface board
- Remove I2C pull-up jumpers at location JP6 and JP7 (need to be open in all positions)
- If the 10-wire ribbon cable is available connect the XCM to the interface board as shown below

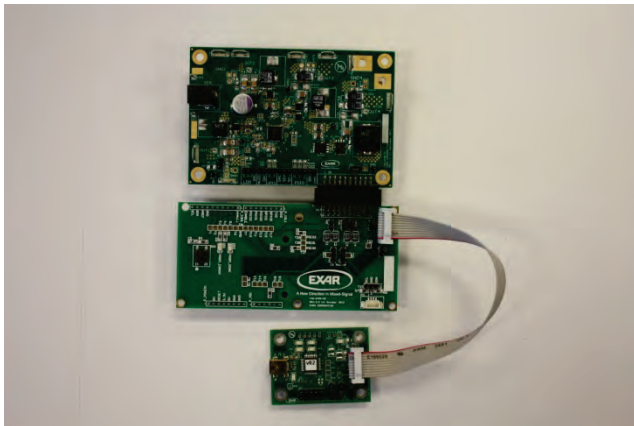

- Use I2C pull-up resistors on XCM (install headers at the locations JP2 and JP3 shorting pins 2 and 3)
- If 10-wire ribbon cable is not available use 3-wire connection between JP4 pins 1-3 on XCM (pin 1 – SCL; pin 2 – GND; pin 3 – SDA) to test points T23 (SCL), T24 (GND) and T25 (SDA) on the interface board. Make a use of the silkscreen labels on both boards.
- Connect the interface board and the evaluation board as shown above.

Wiring XCM directly to the Evaluation Board

Use 3-wire connection between JP4 pins 1-3 on the XCM (pin 1 – SCL; pin 2 – GND; pin 3 – SDA) to the P3 connector on the evaluation board, the pin 8 (GND), the pin 9 (SDA) and the pin 10 (SCL) on the interface board. Make a use of the silkscreen labels on both boards.

EVALUATION BOARD SCHEMATICS

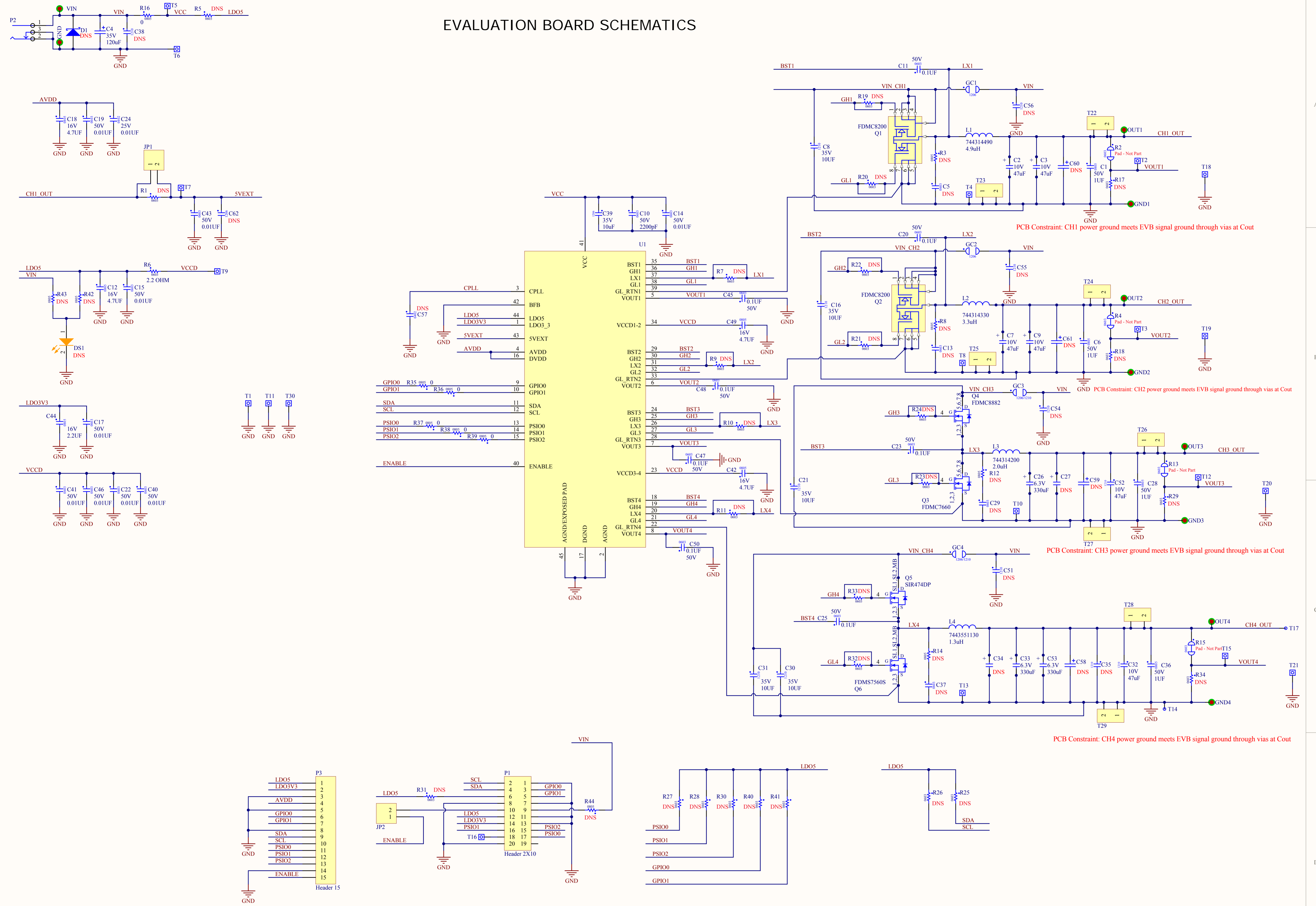

BILL OF MATERIAL

Ref.	Qty	Manufacturer	Part Number	Size	Component
	1	Exar Corporation	146-6708-01	4.05x2.70in	PCB
U1	1	Exar Corporation	XRP7724/XRP7725	TQFN44	2nd Generation 4Ch. Sw. Controller
Q1,Q2	2	Fairchild	FDMC8200	Power 33	Dual N-Channel Power Trench MOSFET
Q3	1	Fairchild	FDMC7660	Power 33	N-Channel Power Trench MOSFET
Q4	1	Fairchild	FDMC8882	MLP 3.3X3.3	N-Channel Power Trench MOSFET
Q5	1	Vishay Siliconix	SIR474DP	PowerPAK SO-8	N-Ch. 30-V (D-S) MOSFET
Q6	1	Fairchild	FDMS7560S	Power 56	N-Channel Power Trench SyncFET
L1	1	Würth Elektronik	744314490	7.0x6.9mm	Inductor 4.9uH, 14.5mΩ, 6.5A
L2	1	Würth Elektronik	744314330	7.0x6.9mm	Inductor 3.3uH, 9.0mΩ, 9.0A
L3	1	Würth Elektronik	744314200	7.0x6.9mm	Inductor 2.0uH, 5.85mΩ, 11.5A
L4	1	Würth Elektronik	7443551130	13.2X12.8mm	Inductor 1.3uH, 1.8mΩ, 25A
C1, C6, C28, C36	4	Murata Corporation	GRM21BR71H105KA12L	0805	Ceramic Capacitor 1μF, 50V, X7R
C2, C3, C7, C9, C32, C52	6	Murata Corporation	GRM32ER71A476KE15L	1210	Ceramic Capacitor 47μF, 10V, X7R
C4	1	Panasonic/Sanyo	35SVPF120M	F12	OSCON Capacitor 120μF, 35V
C8, C16, C21, C30, C31	5	Murata Corporation	GRM32ER71H106KA12L	1210	Ceramic Capacitor 10μF, 50V, X7R
C10	1	Murata Corporation	GRM188R71H222KA01D	0603	Ceramic Capacitor 2200pF, 50V, X7R
C11, C20, C23, C25, C45, C47, C48, C50	8	Murata Corporation	GRM188R71H104KA93D	0603	Ceramic Capacitor 0.1μF, 50V, X7R
C12, C18, C42, C49	4	Murata Corporation	GRM21BR71C475KA73	0805	Ceramic Capacitor 4.7μF, 16V, X7R
C14, C15, C17, C19, C22, C40, C41, C43, C46	9	Murata Corporation	GRM188R71H103KA01D	0603	Ceramic Capacitor 0.01μF, 50V, X7R



A New Direction in Mixed-Signal

XRP7724/7725EVB-DEMO-2

Quad Channel Digital PWM/PFM Demo Board Programmable Power Management System

Ref.	Qty	Manufacturer	Part Number	Size	Component
C24	1	Murata Corporation	GRM155R71H103KA88D	0402	Ceramic Capacitor 0.01 μ F, 50V, X7R
C26, C33, C53	3	Panasonic/Sanyo	6TPF330M9L	7343 D3L	POSCAP Capacitor 330 μ F, 6.3V, 9m Ω
C39	1	TDK Corporation	C3216X7R1V106K160AC	1206	Ceramic Capacitor 10 μ F, 35V, X7R
C44	1	Murata Corporation	GRM21BR71C225KA12L	0805	Ceramic Capacitor 2.2 μ F, 16V, X7R
GC1, GC2	2	Vishay Dale	CRCW12060000Z0EAHP	1206	RES 0 Ω , 1/2W, SMD
GC3, GC4	2	Vishay Dale	CRCW12100000Z0EA	1210	RES 0 Ω , 1/2W, SMD
R6	1	Panasonic	ERJ-3RQF2R2V	0603	RES 2.2 Ω , 1/10W, 1%, SMD
R16, R35, R36, R37, R38, R39	6	Panasonic	ERJ-6GEY0R00V	0805	RES 0 Ω , 1/8W, SMD
JP1, JP2	2	Würth Elektronik	61300211121	0.20x0.10in	Connector, Male Header, 2 Positions, 100mil Spacing, Vertical, TH
P1	1	Sullins Connector Solutions	SFH11-PBPC-D10-RA-BK	1.20x0.55in	Connector, Female Header, 20 Positions, 100mil Spacing, RA, TH
P2	1	Switchcraft	RAPC722X	0.60x0.40in	Connector, Power Jack Mini R/A, T/H
P3	1	Würth Elektronik	61301511121	1.50x0.10in	Connector, Male Header, 15 Positions, 100mil Spacing, Vertical, TH
T1, T4, T8, T10, T13, T30	6	Würth Elektronik	61300111121	0.10x0.10in	Square Test Posts, TH
T22, T23, T24, T25, T26, T27, T28, T29	8	Würth Elektronik	7471287	0.32x0.10in	Mounting Tabs
GND, OUT1, OUT2, OUT3, OUT4, VIN	6	Vector Electronics	K30C/M		Round Test Posts, TH

EVALUATION BOARD LAYOUT

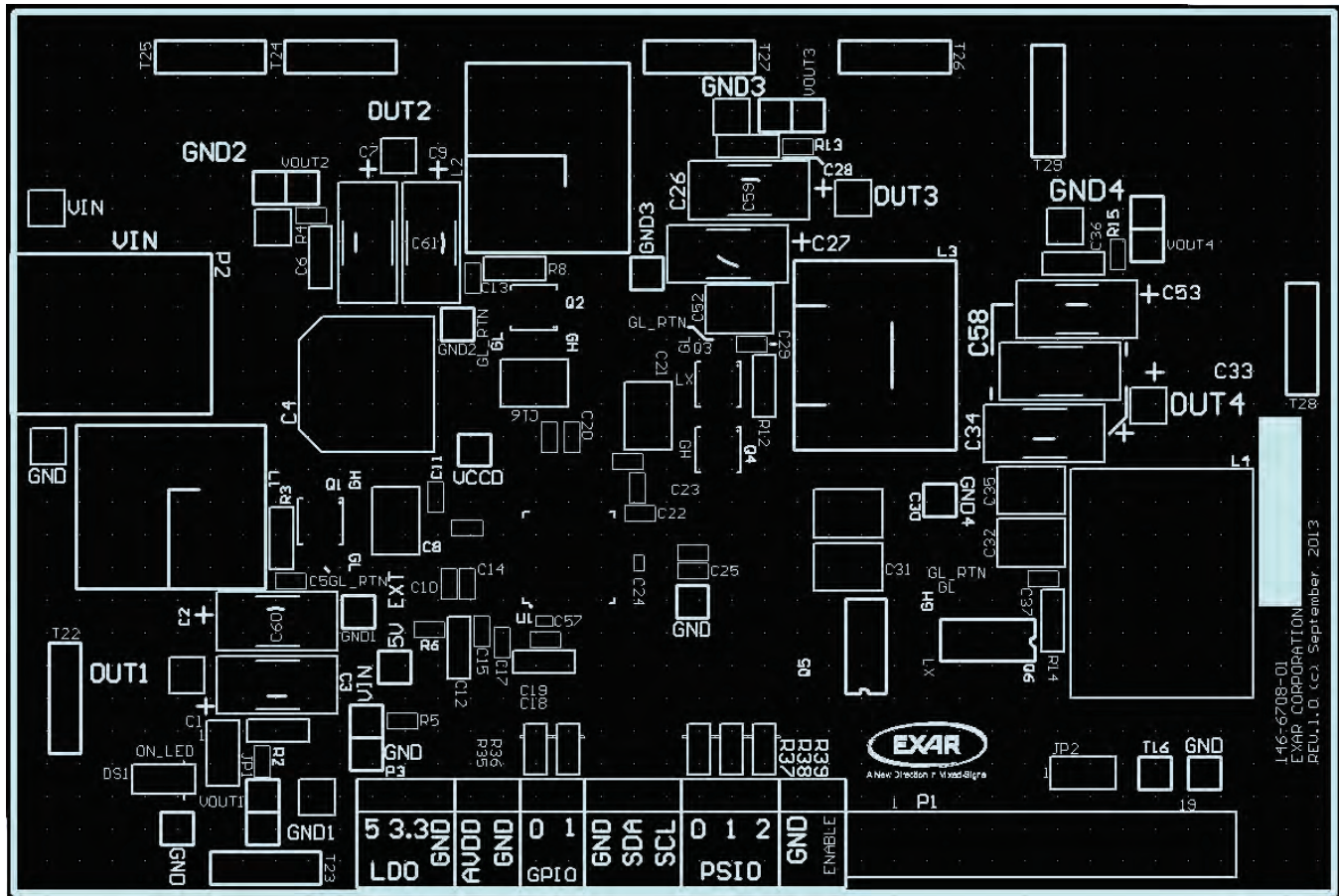

Figure 3 Component Placement – Top Side



A New Direction in Mixed-Signal

XRP7724/7725EVB-DEMO-2

Quad Channel Digital PWM/PFM Demo Board Programmable Power Management System

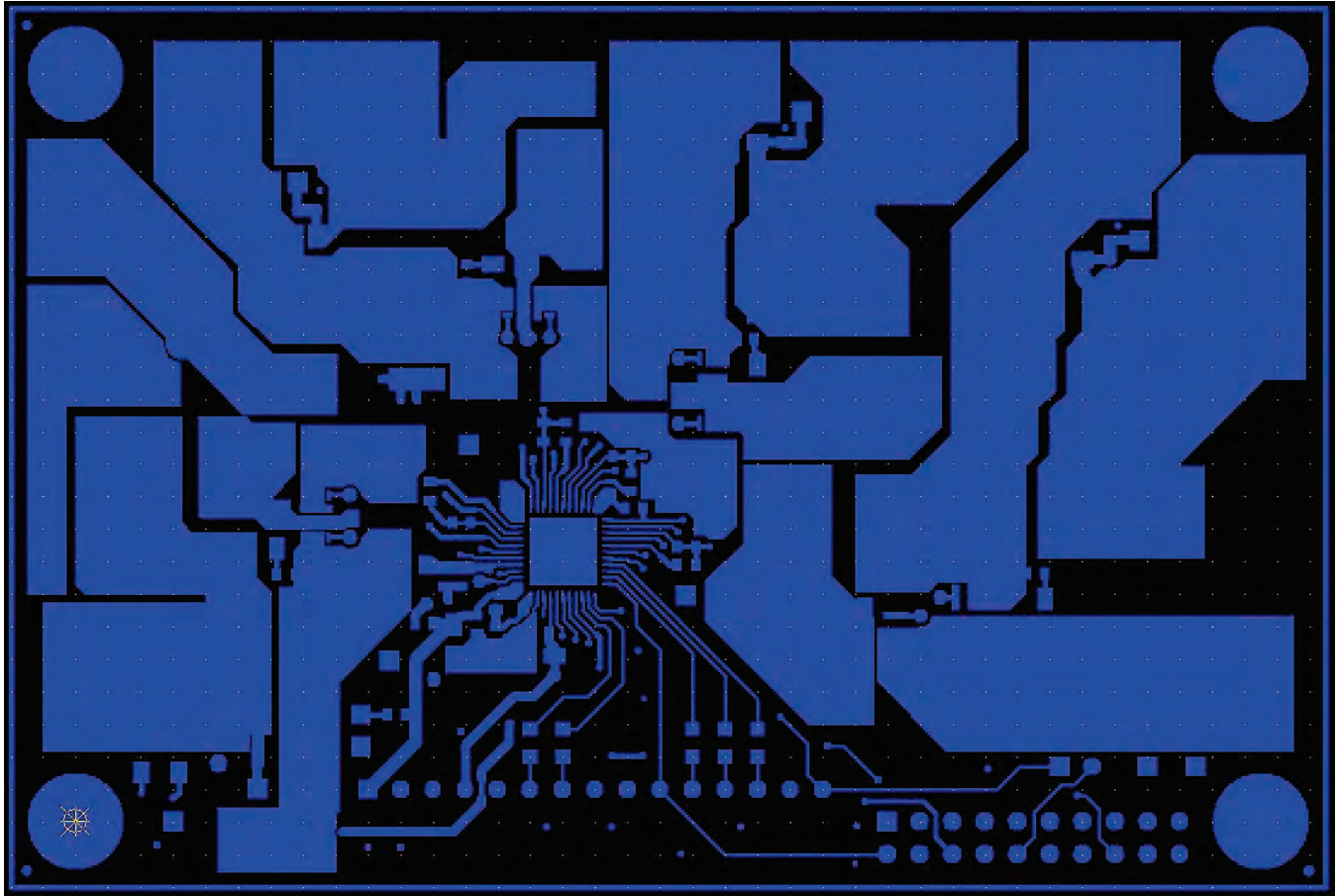

Figure 4 Layout – Top Layer



A New Direction in Mixed-Signal

XRP7724/7725EVB-DEMO-2

Quad Channel Digital PWM/PFM Demo Board Programmable Power Management System

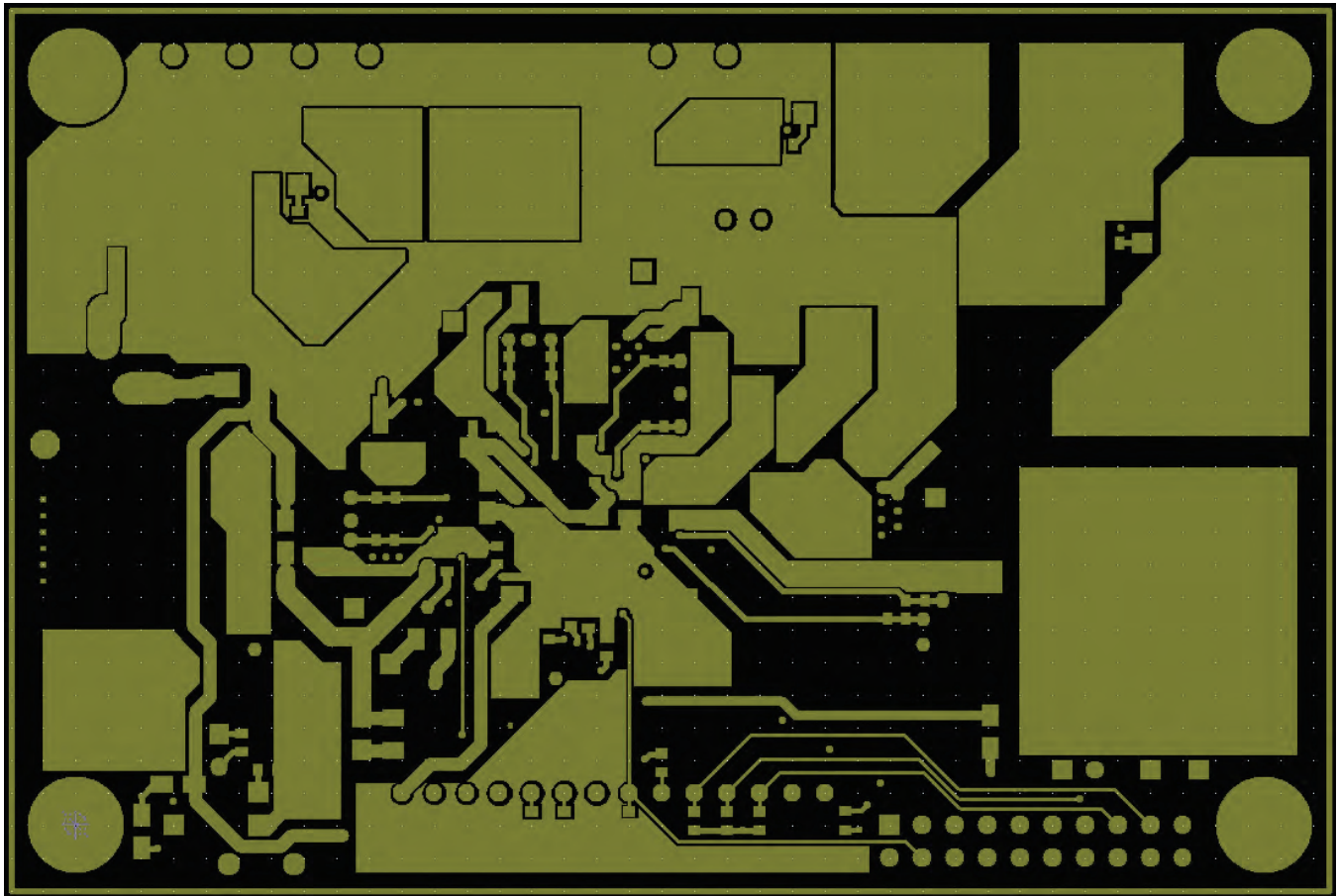

Figure 5 Layout – Bottom Layer

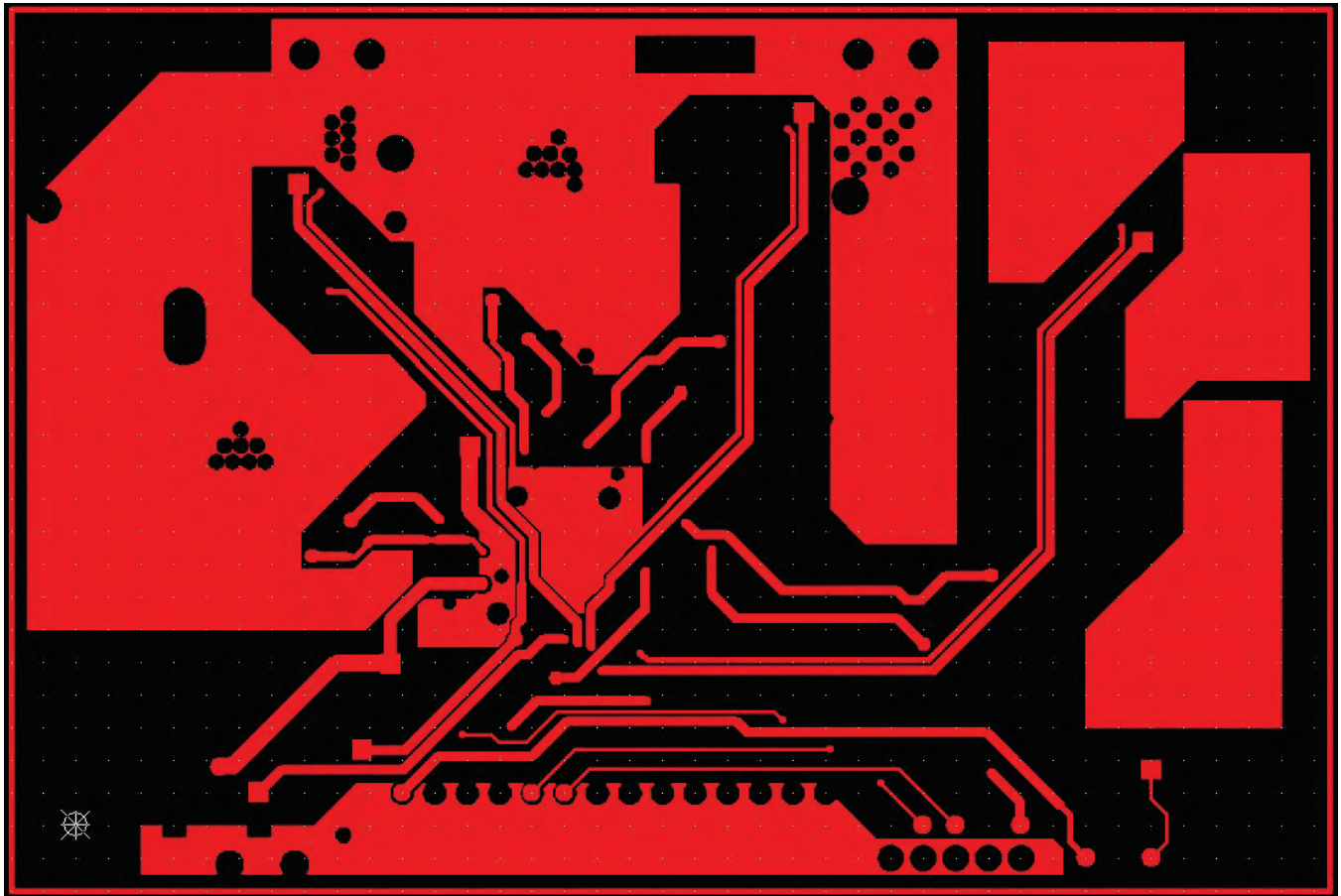

Figure 6 Layout – Middle Layer 1



A New Direction in Mixed-Signal

XRP7724/7725EVB-DEMO-2

Quad Channel Digital PWM/PFM Demo Board Programmable Power Management System

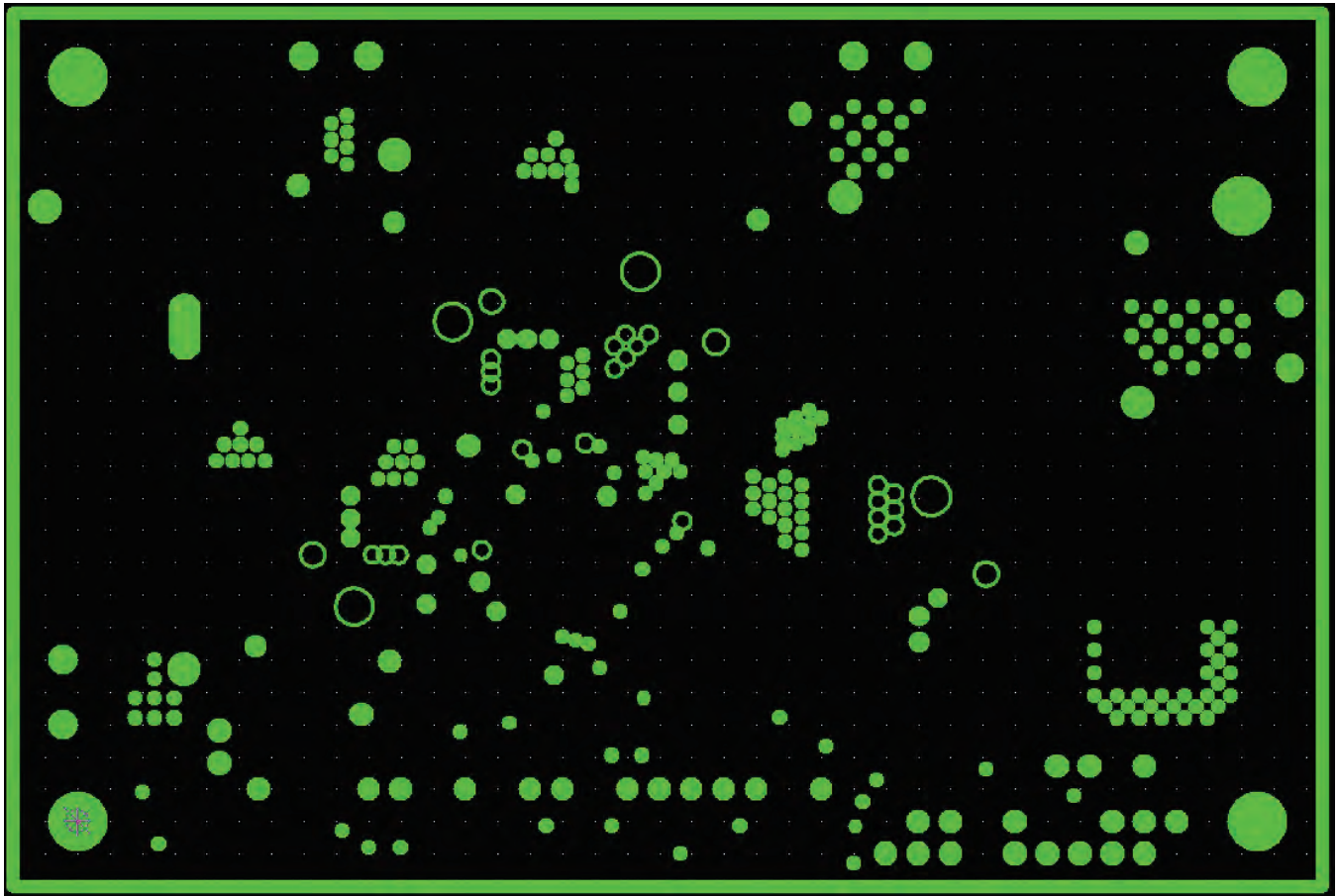
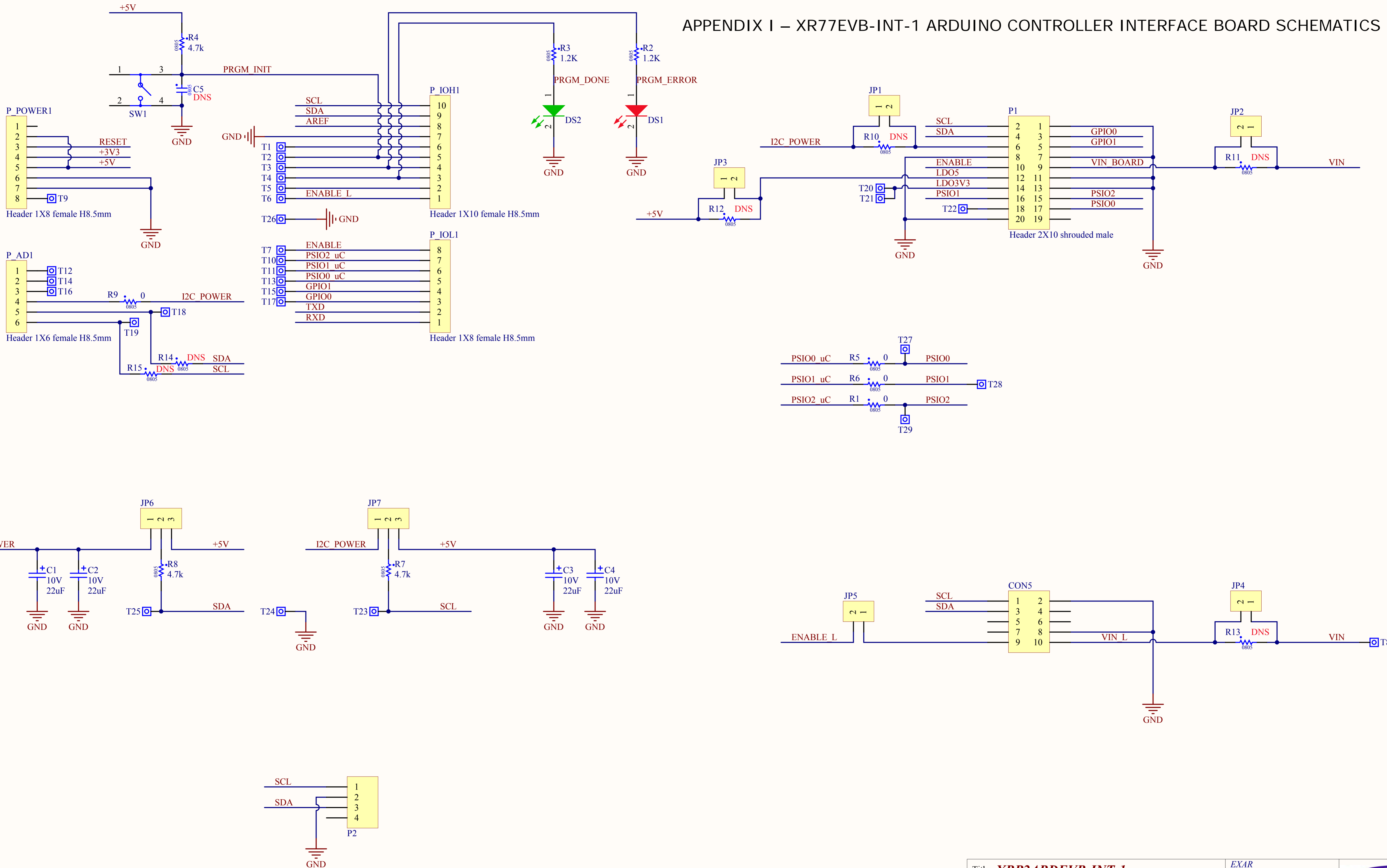

Figure 7 Layout – Signal Ground Plane

APPENDIX I – XR77EVb-INT-1 ARDUINO CONTROLLER INTERFACE BOARD SCHEMATICS



BILL OF MATERIAL - XR77EVB-INT-1 ARDUINO CONTROLLER INTERFACE BOARD

Ref.	Qty	Manufacturer	Part Number	Size	Component
	1	Exar Corporation	146-6703-01	4.40x2.10	PCB
DS1	1	Würth Elektronik	150120RS75000	1206	SMD Red Chip LED
DS2	1	Würth Elektronik	150120VS75000	1206	SMD Green Chip LED
C1, C2, C3, C4	4	Vishay Sprague	293D226X9010B2TE3	B	Tantalum Capacitor 22 μ F, 10V, 10%
R1, R5, R6, R9	4	Panasonic	ERJ-6GEY0R00V	0805	RES 0 Ω , 1/8W, 5% SMD
R2, R3	2	Panasonic	ERJ-6GEYJ122V	0805	RES 1.2k Ω , 1/8W, 5%, SMD
R4, R7, R8	3	Panasonic	ERJ-6GEYJ472V	0805	RES 4.7k Ω , 1/8W, 5%, SMD
SW1	1	Würth Elektronik	430182050816	6x6mm	Tact Switch, SMD
CON5	1	Würth Elektronik	61301021121	0.50x0.20in	Connector, Male Header, 10 Positions, Dual Row, 100mil Spacing, Vertical, TH
JP1, JP2, JP3, JP4, JP5	5	Würth Elektronik	61300211121	0.20x0.10in	Connector, Male Header, 2 Positions, 100mil Spacing, Vertical, TH
JP6, JP7	2	Würth Elektronik	61300311121	0.30x0.10in	Connector, Male Header, 3 Positions, 100mil Spacing, Vertical, TH
P1	1	Würth Elektronik	612020235221	1.20x0.55in	Connector, Male Header, 20 Positions, Dual Row, 100mil Spacing, Shrouded, RA, TH
P2	1	Würth Elektronik	653104124022	11x6mm	Wire-to-Board Connector, Male, 4 Positions, 1.25mm Spacing, Shrouded, SMT
P_IOH1	1	Würth Elektronik	61301011121	1.00x0.10in	Connector, Male Header, 10 Positions, 100mil Spacing, Vertical, TH
P_POWER1, P_IOL1	2	Würth Elektronik	61300811121	0.80x0.10in	Connector, Male Header, 8 Positions, 100mil Spacing, Vertical, TH
P_AD1	1	Würth Elektronik	61300611121	0.60x0.10in	Connector, Male Header, 6 Positions, 100mil Spacing, Vertical, TH
T23, T24, T25	3	Würth Elektronik	61300111121	0.10x0.10in	Square Test Posts, TH



XRP7724/7725EVB-DEMO-2

Quad Channel Digital PWM/PFM Demo Board Programmable Power Management System

DOCUMENT REVISION HISTORY

Revision	Date	Description
1.0.0	05/12/2014	Initial release of document

BOARD REVISION HISTORY

Board Revision	Date	Description
XRP7724/7725EVB-DEMO-2-01	05/12/14	Initial release of the evaluation board

FOR FURTHER ASSISTANCE

Email:

customersupport@exar.com

powertechsupport@exar.com

Exar Technical Documentation:

<http://www.exar.com/TechDoc/default.aspx?>



EXAR CORPORATION

HEADQUARTERS AND SALES OFFICES

48720 Kato Road

Fremont, CA 94538 – USA

Tel.: +1 (510) 668-7000

Fax: +1 (510) 668-7030

www.exar.com

NOTICE

EXAR Corporation reserves the right to make changes to the products contained in this publication in order to improve design, performance or reliability. EXAR Corporation assumes no responsibility for the use of any circuits described herein, conveys no license under any patent or other right, and makes no representation that the circuits are free of patent infringement. Charts and schedules contained here in are only for illustration purposes and may vary depending upon a user's specific application. While the information in this publication has been carefully checked; no responsibility, however, is assumed for inaccuracies.

EXAR Corporation does not recommend the use of any of its products in life support applications where the failure or malfunction of the product can reasonably be expected to cause failure of the life support system or to significantly affect its safety or effectiveness. Products are not authorized for use in such applications unless EXAR Corporation receives, in writing, assurances to its satisfaction that: (a) the risk of injury or damage has been minimized; (b) the user assumes all such risks; (c) potential liability of EXAR Corporation is adequately protected under the circumstances.

Reproduction, in part or whole, without the prior written consent of EXAR Corporation is prohibited.



Компания «ЭлектроПласт» предлагает заключение долгосрочных отношений при поставках импортных электронных компонентов на взаимовыгодных условиях!

Наши преимущества:

- Оперативные поставки широкого спектра электронных компонентов отечественного и импортного производства напрямую от производителей и с крупнейших мировых складов;
- Поставка более 17-ти миллионов наименований электронных компонентов;
- Поставка сложных, дефицитных, либо снятых с производства позиций;
- Оперативные сроки поставки под заказ (от 5 рабочих дней);
- Экспресс доставка в любую точку России;
- Техническая поддержка проекта, помощь в подборе аналогов, поставка прототипов;
- Система менеджмента качества сертифицирована по Международному стандарту ISO 9001;
- Лицензия ФСБ на осуществление работ с использованием сведений, составляющих государственную тайну;
- Поставка специализированных компонентов (Xilinx, Altera, Analog Devices, Intersil, Interpoint, Microsemi, Aeroflex, Peregrine, Syfer, Eurofarad, Texas Instrument, Miteq, Cobham, E2V, MA-COM, Hittite, Mini-Circuits, General Dynamics и др.);

Помимо этого, одним из направлений компании «ЭлектроПласт» является направление «Источники питания». Мы предлагаем Вам помощь Конструкторского отдела:

- Подбор оптимального решения, техническое обоснование при выборе компонента;
- Подбор аналогов;
- Консультации по применению компонента;
- Поставка образцов и прототипов;
- Техническая поддержка проекта;
- Защита от снятия компонента с производства.



Как с нами связаться

Телефон: 8 (812) 309 58 32 (многоканальный)

Факс: 8 (812) 320-02-42

Электронная почта: org@eplast1.ru

Адрес: 198099, г. Санкт-Петербург, ул. Калинина, дом 2, корпус 4, литера А.