

PERFORMANCE SPECIFICATION SHEET

CIRCUIT BREAKERS, MAGNETIC, PANEL SEAL,  
TRIP-FREE, SERIES TRIP, THREE POLE  
(0.2 TO 30 AMPERES)

This specification is approved for use by all Departments and Agencies of the Department of Defense.

The requirements for acquiring the product described herein shall consist of this specification sheet and [MIL-PRF-55629](#).

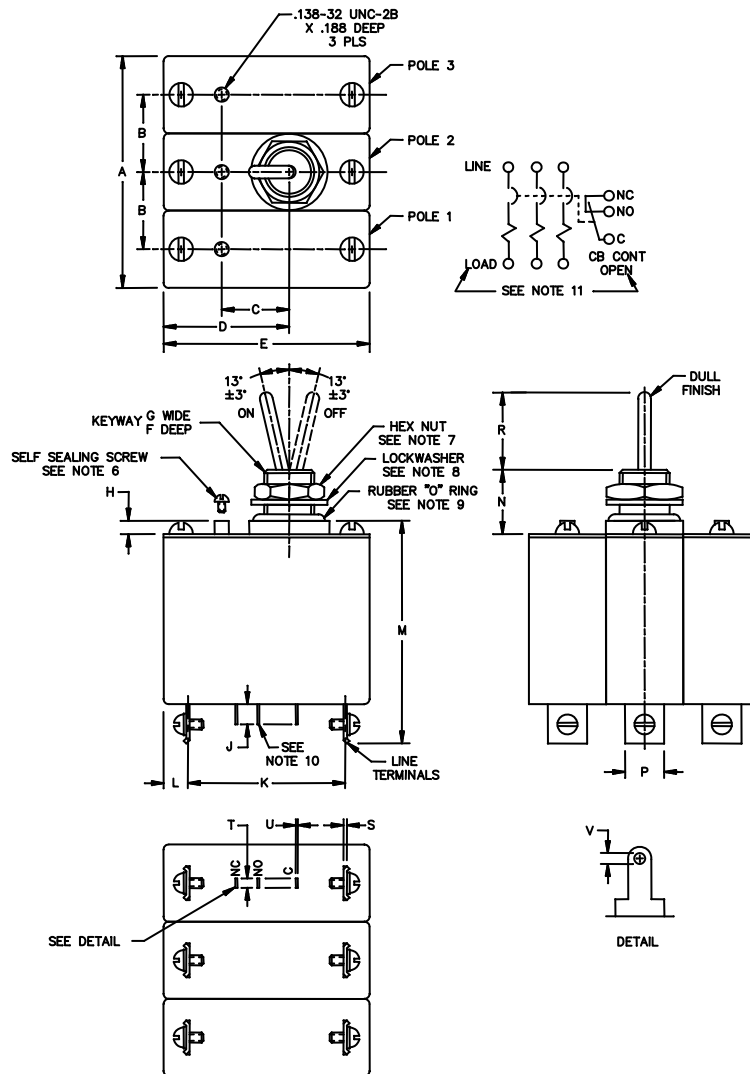

FIGURE 1. Dimensions and configurations (configuration 1).

Ltr	Inches		mm	
	Min	Max	Min	Max
A	---	2.265	---	
B	.735	.765	18.67	19.43
C	.641	.671	16.28	17.04
D	1.189	1.251	30.20	31.78
E	1.969	2.031	50.01	51.59
F	.030	.035	0.76	0.89
G	.060	.065	1.52	1.65
H	.115	.145	2.92	3.68
J	.312 REF	.374 REF	7.92 REF	9.50 REF
K	1.499	1.561	38.07	39.65
L	.199	.261	5.05	6.63
M	---	2.232	---	56.69
N	.594	.656	15.09	16.66
P	.349	.395	8.86	10.03
R	.719	.781	18.26	19.84
S	.030	.035	0.76	0.89
T	.079 REF	.141 REF	2.01 REF	3.58 REF
U	.019 REF	.021 REF	0.48 REF	0.53 REF
V	.019 REF	.081 REF	0.48 REF	2.06 REF

## NOTES:

1. Dimensions are in inches.
2. Metric equivalents are given for general information only.
3. Unless otherwise specified, tolerance is  $\pm 0.031$  (0.79 mm).
4. Lockwasher, split, No. 8 [NASM35338-137](#) or equivalent.
5. Terminal screw, No. 8, .164-32 UNC-2A, .187  $\pm 0.015$  long, material: Brass, tin plated ([ASTM-B545](#) or equivalent).
6. Passivated - corrosion resisting steel screw, slotted head with integral O-ring, may be replaced by the [NASM3212-12](#) with cross-recessed head or equivalent.
7. Hex mounting nut .500-32 UNF-2B thread, .625  $\pm 0.010$  across flats, .120/.125 thick, brass nickel plated, [SAE-AMS-QQ-N-290](#) nonglare; may be replaced with [MS25082-B22](#) or equivalent.
8. Internal tooth lockwasher, .625  $\pm 0.005$  O.D., .510  $\pm 0.005$  I.D., .028  $\pm 0.005$  thick, stainless steel.
9. O-ring, material: Material shall be selected to enable the O-ring to meet the performance requirements of this specification. Butadiene acrylonitrile has been successfully used in the past and should be considered for meeting the O-ring requirements of the specification.
10. Auxiliary switch terminals shall provide for soldered connections.
11. Physical item marking of the words "LOAD" and "CB CONT OPEN" is optional.

FIGURE 1. Dimensions and configurations (configuration 1) – Continued.

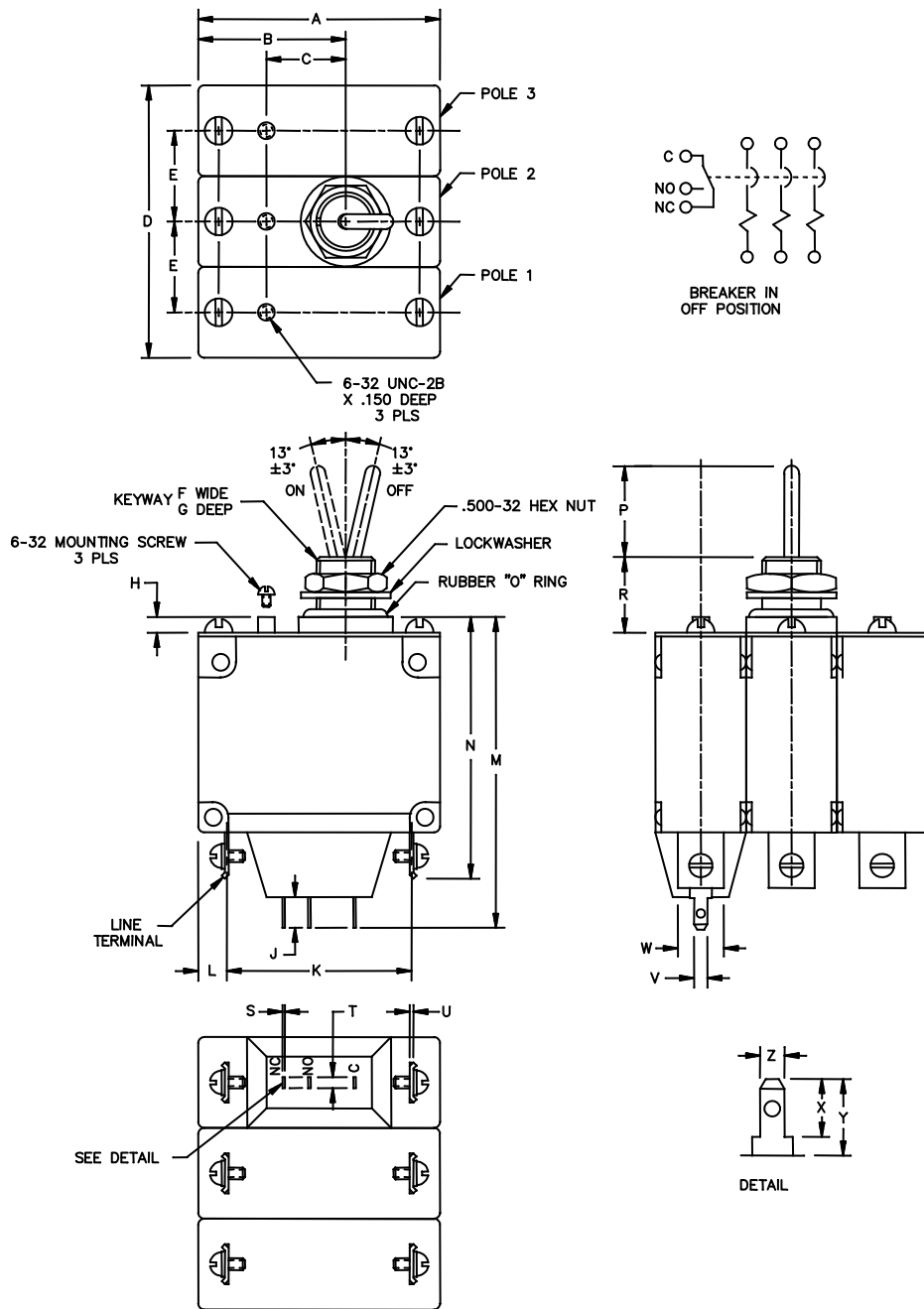

FIGURE 2. Dimensions and configurations (configuration 2).

Ltr	Inches		mm	
	Min	Max	Min	Max
A	1.985	2.015	50.42	51.18
B	1.205	1.235	30.61	31.37
C	.641	.671	16.28	17.04
D	---	2.265	---	57.53
E	.735	.765	18.67	19.43
F	.060	.065	1.52	1.65
G	.030	.035	0.76	0.89
H	.115	.145	2.92	3.68
J	.280	.310	7.11	7.87
K	1.515	1.545	38.48	39.24
L	.215	.245	5.46	6.22
M	---	2.620	---	66.55
N	---	2.256	---	57.30
P	.735	.765	18.67	19.43
R	.610	.640	15.50	16.26
S	.019	.021	0.48	0.53
T	.095	.125	2.41	3.18
U	.030	.033	0.76	0.84
V	.095	.125	2.41	3.18
W	.360	.390	9.14	9.91
X	.245	.275	6.22	6.99
Y	.329	.359	8.36	9.12
Z	.095	.125	2.41	3.18

## NOTES:

1. Dimensions are in inches.
2. Metric equivalents are given for general information only.
3. Unless otherwise specified, tolerance is  $\pm .015$  (0.38 mm).
4. Lockwasher, split, No. 8 [NASM35338-137](#) or equivalent.
5. Terminal screw, No. 8, .164-32UNC-2A, .187  $\pm$ .015 long. Material: Brass, tin plated ([ASTM B545](#) or equivalent).
6. Passivated - corrosion resisting steel screw - slotted head with integral O-ring, may be replaced by the [NASM3212-12](#) with cross-recessed head or equivalent.
7. Hex mounting nut: .500 - 32 UNF-2B thread, .625  $\pm$ .010 across flats, .120/.125 thick, brass nickel plated, [SAE-AMS-QQ-N-290](#) nonglare or equivalent; may be replaced with [MS25082-B22](#) or equivalent.
8. Internal tooth lockwasher, .625  $\pm$ .005 O.D., .510  $\pm$ .005 I.D., .028  $\pm$ .005 thick, stainless steel.
9. O-ring, material: Material shall be selected to enable the O-ring to meet the performance requirements of this specification. Butadiene acrylonitrile has been successfully used in the past and should be considered for meeting the O-ring requirements of the specification.
10. Auxiliary switch terminals shall provide for soldered connections.
11. Physical item marking of the words "LOAD" and "CB CONT OPEN" is optional.

FIGURE 2. Dimensions and configurations (configuration 2) - Continued.

## REQUIREMENTS

Dimensions and configuration: See figure 1 and figure 2.

Current ratings: See table I.

High Inrush: Applies unless otherwise specified. 1/

Voltage ratings: See table II. Ratings are maximum; the minimum operating voltage is limited by the internal resistance or impedance of the circuit breaker (see table I).

Auxiliary contacts:

Contact capacity shall be 10 amperes to 250 volts 60/400 Hz and 2 amperes resistive, 1 ampere inductive to 50 V dc.

Tripping-time delays: See table I and table II.

Terminal and mounting hardware: See figure 1.

Terminals: See figure 1. Solderability is applicable to auxiliary contact terminals.

Actuator strength: 25 pounds.

Actuator operating force: 12 pounds, maximum.

Terminal strength:

Applied load: 30 pounds.

Applied torque: 10 inch-pounds.

Interrupting capacities:

2,000 amperes at 50 V dc.

2,000 amperes at 120 V ac, 60 Hz.

1,500 amperes at 120 V ac, 400 Hz.

1,000 amperes at 240 V ac, 60 and 400 Hz.

Seal: Panel seal test applies.

MIL-PRF-55629/22G

Part or Identifying Number (PIN): The PIN to be cataloged and stocked by the Government consists of the prefix M55629/22 and six succeeding code letters as follows: 1/, 2/

For pole identification, see figure 1

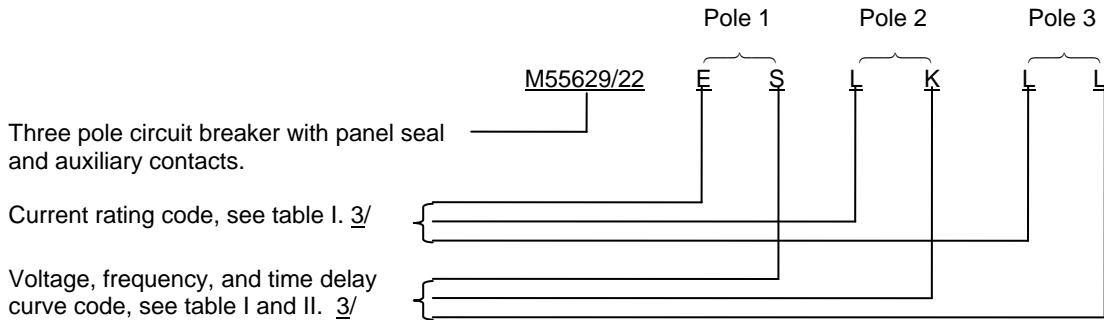

Three pole circuit breaker with panel seal and auxiliary contacts.

Current rating code, see table I. 3/

Voltage, frequency, and time delay curve code, see table I and II. 3/

When circuit breakers without auxiliary contacts, are installed in new equipment, replacement spares should possess this feature since it is more economical for the DoD to stock one version of this item instead of two. Therefore, stock numbers should not be requested (or assigned) for this special PIN.

- 1/ Special PINs for equipment manufacturers use only. Equipment manufacturers who do not require the auxiliary contacts in specific production applications may order circuit breakers without this feature by modifying the prefix as follows: M55629/22XXXXXX. Replace slash with A for items without auxiliary contacts (M55629A22XXXXXX).
- 2/ Replace slash with D for items requiring configuration 2 (M55629D22XXXXXX). Replace slash with E for items requiring configuration 2 without auxiliary contacts (M55629E22XXXXXX). Replace slash with F for items requiring configuration 2 without the high-inrush feature (M55629F22XXXXXX). Replace slash with G for items requiring configuration 2 without the high-inrush feature or auxiliary contacts (M55629G22XXXXXX).
- 3/ If all poles have identical ratings, code letters will repeat for each pole. If all poles are not identical, poles 1, 2, and 3, respectively (see figure 1) shall be coded in ascending order of the current rating code letter. If all poles have identical current ratings but different voltage, frequency, and time delay code letters, then these code letters shall be coded in ascending order.

TABLE I. Circuit breaker dash numbers and applicable characteristics (configuration 1).

Current rating		Voltage frequency and tripping time delay code letter from table II	Resistance or impedance ohms (max)	Current rating		Voltage frequency and tripping time delay code letter from table II	Resistance or impedance ohms (max)
Amperes	Code letter			Amperes	Code letter		
0.1	A	K or L	120 at dc	4.0	K	K or L	.1 at dc
0.1	A	M or N	120 at 60 Hz	4.0	K	M or N	.1 at 60 Hz
0.1	A	P, R, or S	350 at 400 Hz	4.0	K	P, R, or S	.3 at 400 Hz
0.250	B	K or L	21 at dc	5.0	L	K or L	.08 at dc
0.250	B	M or N	23 at 60 Hz	5.0	L	M or N	.08 at 60 Hz
0.250	B	P, R, or S	43 at 400 Hz	5.0	L	P, R, or S	.15 at 400 Hz
0.35	C	K or L	12 at dc	7.5	M	K or L	.035 at dc
0.35	C	M or N	12 at 60 Hz	7.5	M	M or N	.035 at 60 Hz
0.35	C	P, R, or S	30 at 400 Hz	7.5	M	P, R, or S	.11 at 400 Hz
0.5	D	K or L	6 at dc	10.0	N	K or L	.02 at dc
0.5	D	M or N	6 at 60 Hz	10.0	N	M or N	.02 at 60 Hz
0.5	D	P, R, or S	12 at 400 Hz	10.0	N	P, R, or S	.04 at 400 Hz
0.75	E	K or L	3 at dc	12.5	P	K or L	.013 at dc
0.75	E	M or N	3 at 60 Hz	12.5	P	M or N	.015 at 60 Hz
0.75	E	P, R, or S	7 at 400 Hz	12.5	P	P, R, or S	.03 at 400 Hz
1.0	F	K or L	2 at dc	15.0	R	K or L	.01 at dc
1.0	F	M or N	2 at 60 Hz	15.0	R	M or N	.011 at 60 Hz
1.0	F	P, R, or S	4 at 400 Hz	15.0	R	P, R, or S	.02 at 400 Hz
1.75	G	K or L	0.9 at dc	20.0	S	K or L	.007 at dc
1.75	G	M or N	0.9 at 60 Hz	20.0	S	M or N	.007 at 60 Hz
1.75	G	P, R, or S	2 at 400 Hz	20.0	S	P, R, or S	.01 at 400 Hz
2.5	H	K or L	.35 at dc	25.0	T	K or L	.006 at dc
2.5	H	M or N	.35 at 60 Hz	25.0	T	M or N	.006 at 60 Hz
2.5	H	P, R, or S	.6 at 400 Hz	25.0	T	P, R, or S	.007 at 400 Hz
3.0	J	K or L	.3 at dc	30.0	U	K or L	.005 at dc
3.0	J	M or N	.3 at 60 Hz	30.0	U	M or N	.005 at 60 Hz
3.0	J	P, R, or S	.5 at 400 Hz	30.0	U	P, R, or S	.006 at 400 Hz

TABLE II. Circuit breaker dash numbers and applicable characteristics (configuration 2).

Current rating		Voltage frequency and tripping time delay code letter from table II	Resistance or impedance ohms (max)	Current rating		Voltage frequency and tripping time delay code letter from table II	Resistance or impedance ohms (max)
Amperes	Code letter			Amperes	Code letter		
0.1	A	K or L	186 at dc	4.0	K	K or L	0.113 at dc
0.1	A	M or N	142 at 60 Hz	4.0	K	M or N	0.1 at 60 Hz
0.1	A	P, R, or S	350 at 400 Hz	4.0	K	P, R, or S	0.3 at 400 Hz
0.250	B	K or L	26.4 at dc	5.0	L	K or L	0.08 at dc
0.250	B	M or N	26.4 at 60 Hz	5.0	L	M or N	0.08 at 60 Hz
0.250	B	P, R, or S	60 at 400 Hz	5.0	L	P, R, or S	0.175 at 400 Hz
0.35	C	K or L	13.2 at dc	7.5	M	K or L	0.035 at dc
0.35	C	M or N	13.2 at 60 Hz	7.5	M	M or N	0.035 at 60 Hz
0.35	C	P, R, or S	30 at 400 Hz	7.5	M	P, R, or S	0.11 at 400 Hz
0.5	D	K or L	6 at dc	10.0	N	K or L	0.02 at dc
0.5	D	M or N	6.36 at 60 Hz	10.0	N	M or N	0.02 at 60 Hz
0.5	D	P, R, or S	13.2 at 400 Hz	10.0	N	P, R, or S	0.04 at 400 Hz
0.75	E	K or L	3 at dc	12.5	P	K or L	0.016 at dc
0.75	E	M or N	3 at 60 Hz	12.5	P	M or N	0.015 at 60 Hz
0.75	E	P, R, or S	7 at 400 Hz	12.5	P	P, R, or S	0.03 at 400 Hz
1.0	F	K or L	2 at dc	15.0	R	K or L	0.012 at dc
1.0	F	M or N	2 at 60 Hz	15.0	R	M or N	0.011 at 60 Hz
1.0	F	P, R, or S	4 at 400 Hz	15.0	R	P, R, or S	0.02 at 400 Hz
1.75	G	K or L	0.9 at dc	20.0	S	K or L	0.0075 at dc
1.75	G	M or N	0.9 at 60 Hz	20.0	S	M or N	0.007 at 60 Hz
1.75	G	P, R, or S	2 at 400 Hz	20.0	S	P, R, or S	0.01 at 400 Hz
2.5	H	K or L	0.35 at dc	25.0	T	K or L	0.006 at dc
2.5	H	M or N	0.35 at 60 Hz	25.0	T	M or N	0.006 at 60 Hz
2.5	H	P, R, or S	0.7 at 400 Hz	25.0	T	P, R, or S	0.009 at 400 Hz
3.0	J	K or L	0.3 at dc	30.0	U	K or L	0.005 at dc
3.0	J	M or N	0.3 at 60 Hz	30.0	U	M or N	0.005 at 60 Hz
3.0	J	P, R, or S	0.5 at 400 Hz	30.0	U	P, R, or S	0.006 at 400 Hz



TABLE III. Operating voltage, frequency, and tripping-time delay delay (configuration 1). 1/

Time delay percent rated current	Tripping-time delay at 25°C ±2°C (tripping time in seconds)													
	50 V dc				240 V ac, 60 Hz				240 V ac, 400 Hz					
	K		L		M		N		P		R		S	
	Max	Min	Max	Min	Max	Min	Max	Min	Max	Min	Max	Min	Max	Min
100	no trip one hour		no trip one hour		no trip one hour		no trip one hour		no trip one hour		no trip one hour		no trip one hour	
125	100	10	12	.5	120	10	18	1	N/A	N/A	N/A	N/A	N/A	N/A
150	N/A	N/A	N/A	N/A	N/A	N/A	N/A	N/A	60	6	5.8	.6	500	60
200	20	2.5	1.5	.13	20	3	1.6	.16	20	2.1	2	.2	160	20
400	2	.36	.29	.031	2.3	.3	.3	.04	4	.4	.35	.035	19	2
600	1	.13	.15	Inst	.1	.13	.17	Inst	.6	Inst	.125	Inst	3.5	.250
800	.6	Inst	.06	Inst	.6	Inst	.09	Inst	.06	Inst	.05	Inst	.5	.025
1,000	.29	Inst	.05	Inst	.29	Inst	.043	Inst	.045	Inst	.036	Inst	.043	Inst
1,800	no trip		no trip		no trip		no trip		no trip		no trip		no trip	
2/	no trip		no trip		no trip		no trip		no trip		no trip		no trip	

See footnotes at end of table IV.

6

MIL-PRF-55629/22G

TABLE IV. Operating voltage, frequency, and tripping-time delay (configuration 1) - Continued. <sup>1/</sup>

Time delay percent rated current	Tripping-time delay at high and low temperature °C (tripping time in seconds) <sup>3/</sup>													
	50 V dc				240 V ac, 60 Hz				240 V ac, 400 Hz					
	K		L		M		N		P		R		S	
	-40° Max	+85° Min	-40° Max	+85° Min	-40° Max	+85° Min	-40° Max	+85° Min	-40° Max	+85° Min	-40° Max	+85° Min	-40° Max	+85° Min
100	no trip one hour		no trip one hour		no trip one hour		no trip one hour		no trip one hour		no trip one hour		no trip one hour	
125	500	.5	100	.1	500	1	100	.1	N/A	N/A	N/A	N/A	N/A	N/A
150	N/A	N/A	N/A	N/A	N/A	N/A	N/A	N/A	500	.5	100	.1	1500	5
200	100	.1	10	.05	100	.05	10	.05	100	.1	10	.05	500	.5
400	20	Inst	3	Inst	20	Inst	3	Inst	20	Inst	3	Inst	100	Inst
600	5	Inst	1	Inst	5	Inst	1	Inst	5	Inst	1	Inst	5	Inst
800	2	Inst	.5	Inst	.5	Inst	.5	Inst	.5	Inst	.5	Inst	.5	Inst

<sup>1/</sup> Circuit breakers shall not trip at 100 percent rated current but must trip at 125 or 150 percent of rated current. Between 100 percent and 125 or 150 percent, they may trip. Instantaneous is defined as less than 15 milliseconds.

<sup>2/</sup> Items without the high-inrush feature (for use in production only) are not subject to this requirement. High-inrush test shall be performed using one alternation which has a peak value of 1800 percent of rated current. 400 Hz and dc delays shall be subjected to a 400 Hz waveform, 60 Hz delays shall be subjected to a 60 Hz waveform.

<sup>3/</sup> High and low test temperature tolerances are  $\pm 2^{\circ}\text{C}$ .

TABLE V. Operating voltage, frequency, and tripping-time delay (configuration 2). 1/

Time delay percent rated current	Tripping-time delay at 25°C ±2°C (tripping time in seconds)													
	50 V dc				240 V ac, 60 Hz				240 V ac, 400 Hz					
	K		L		M		N		P		R		S	
	Max	Min	Max	Min	Max	Min	Max	Min	Max	Min	Max	Min	Max	Min
100	no trip one hour		no trip one hour		no trip one hour		no trip one hour		no trip one hour		no trip one hour		no trip one hour	
125	60	7	6.5	0.5	120	10	12	0.7	N/A	N/A	N/A	N/A	N/A	N/A
150	N/A	N/A	N/A	N/A	N/A	N/A	N/A	N/A	70	5	8	0.5	400	40
200	10	0.6	1.2	0.13	20	2.2	3	0.13	25	2.1	1.9	0.15	150	9.5
400	2	0.15	0.5	0.031	3	0.3	1	0.03	5	0.4	0.4	0.02	19	1.9
600	1	Inst	0.25	Inst	2	Inst	0.3	Inst	2.4	Inst	0.25	Inst	7	Inst
800	0.5	Inst	0.1	Inst	0.8	Inst	0.15	Inst	1	Inst	0.1	Inst	0.4	Inst
1,000	0.1	Inst	Inst	Inst	0.25	Inst	0.1	Inst	0.1	Inst	0.05	Inst	0.043	Inst
1,800 2/	no trip		no trip		no trip		no trip		no trip		no trip		no trip	

See footnotes at end of table VI.

TABLE VI. Operating voltage, frequency, and tripping-time delay (configuration 2) - Continued. <sup>1/</sup>

Time delay percent rated current	Tripping-time delay at high and low temperature °C (tripping time in seconds)													
	50 V dc				240 V ac, 60 Hz				240 V ac, 400 Hz					
	K		L		M		N		P		R		S	
	-40°C Max	+85°C Min	-40°C Max	+85°C Min	-40°C Max	+85°C Min	-40°C Max	+85°C Min	-40°C Max	+85°C Min	-40°C Max	+85°C Min	-40°C Max	+85°C Min
100	no trip one hour		no trip one hour		no trip one hour		no trip one hour		no trip one hour		no trip one hour		no trip one hour	
125	500	5	100	0.1	700	1	100	0.1	N/A	N/A	N/A	N/A	N/A	N/A
150	N/A	N/A	N/A	N/A	N/A	N/A	N/A	N/A	600	0.5	100	0.1	1500	5
200	100	0.1	10	0.05	160	0.05	10	0.05	130	0.1	10	0.05	500	0.5
400	20	Inst	3	Inst	26	Inst	3	Inst	32	Inst	3	Inst	100	Inst
600	5	Inst	1	Inst	13	Inst	1	Inst	26	Inst	1	Inst	24	Inst
800	2	Inst	0.5	Inst	2.8	Inst	0.5	Inst	8.4	Inst	0.5	Inst	3	Inst

<sup>1/</sup> Circuit breakers shall not trip at 100 percent rated current but must trip at 125 or 150 percent of rated current. Between 100 percent and 125 or 150 percent, they may trip. Instantaneous is defined as less than 15 milliseconds.

<sup>2/</sup> High-inrush test shall be performed using one alternation, which has a peak value of 1,800 percent of rated current. 400 Hz and dc delays shall be subjected to a 400 Hz waveform, 60 Hz delays shall be subjected to a 60 Hz waveform.

<sup>3/</sup> High and low test temperature tolerances are  $\pm 2$  degree Celsius.

Circuit breakers covered by this specification replace commercial types as specified in table III providing they have equivalent current, voltage, frequency, and time delay ratings.

Circuit breakers without either auxiliary contacts or the high-inrush feature should be replaced by equivalently rated military items with both of these features.

TABLE VII. Supersession and substitution data.

Superseding military PIN	Superseded manufacturers PIN
M55629/22XXXXXX	CAGE 81541
	Type APGN-666
	UPGN-666 IEGN-666

Reference documents. In addition to [MIL-PRF-55629](#), this document references the following:

- [ASTM-B545](#)
- [MS25082](#)
- [NASM3212](#)
- [NASM35338](#)
- [SAE-AMS-QQ-N-290](#)

| The margins of this specification are marked with vertical lines to indicate where changes from the previous issue were made. This was done as a convenience only and the Government assumes no liability whatsoever for any inaccuracies in these notations. Bidders and contractors are cautioned to evaluate the requirements of this document based on the entire content irrespective of the marginal notations and relationship to the last previous issue.

Custodians:  
 Army - CR  
 Navy - EC  
 Air Force - 85  
 DLA - CC

Preparing activity:  
 Army - CR  
 Agent:  
 DLA - CC

| Review activities:  
 Army - AV, CR4, MI  
 Navy - AS, MC, OS  
 Air Force - 19, 99

(Project 5925-2010-022)

NOTE: The activities listed above were interested in this document as of the date of this document. Since organizations and responsibilities can change, you should verify the currency of the information above using the ASSIST Online database at <https://assist.daps.dla.mil>.



Компания «ЭлектроПласт» предлагает заключение долгосрочных отношений при поставках импортных электронных компонентов на взаимовыгодных условиях!

Наши преимущества:

- Оперативные поставки широкого спектра электронных компонентов отечественного и импортного производства напрямую от производителей и с крупнейших мировых складов;
- Поставка более 17-ти миллионов наименований электронных компонентов;
- Поставка сложных, дефицитных, либо снятых с производства позиций;
- Оперативные сроки поставки под заказ (от 5 рабочих дней);
- Экспресс доставка в любую точку России;
- Техническая поддержка проекта, помощь в подборе аналогов, поставка прототипов;
- Система менеджмента качества сертифицирована по Международному стандарту ISO 9001;
- Лицензия ФСБ на осуществление работ с использованием сведений, составляющих государственную тайну;
- Поставка специализированных компонентов (Xilinx, Altera, Analog Devices, Intersil, Interpoint, Microsemi, Aeroflex, Peregrine, Syfer, Eurofarad, Texas Instrument, Miteq, Cobham, E2V, MA-COM, Hittite, Mini-Circuits, General Dynamics и др.);

Помимо этого, одним из направлений компании «ЭлектроПласт» является направление «Источники питания». Мы предлагаем Вам помощь Конструкторского отдела:

- Подбор оптимального решения, техническое обоснование при выборе компонента;
- Подбор аналогов;
- Консультации по применению компонента;
- Поставка образцов и прототипов;
- Техническая поддержка проекта;
- Защита от снятия компонента с производства.



#### Как с нами связаться

**Телефон:** 8 (812) 309 58 32 (многоканальный)

**Факс:** 8 (812) 320-02-42

**Электронная почта:** [org@eplast1.ru](mailto:org@eplast1.ru)

**Адрес:** 198099, г. Санкт-Петербург, ул. Калинина, дом 2, корпус 4, литера А.