

# Ceramic Capacitor Solutions

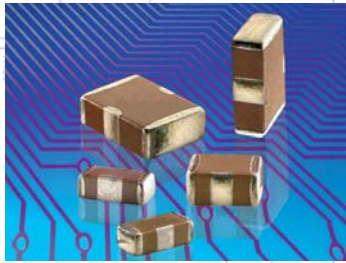

**X2Y Low ESL**



**High Voltage**

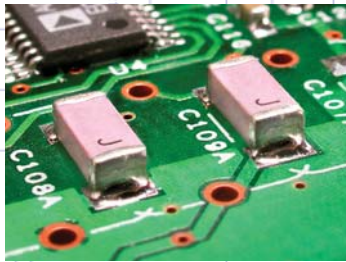

**AC Safety**

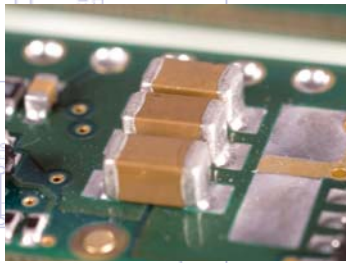

**High Capacitance**



**Stacked SMPS**

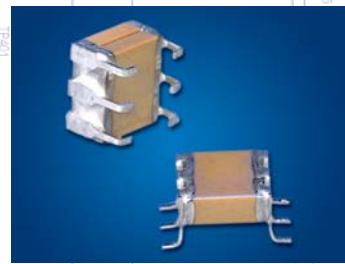

**Mini-SMPS**

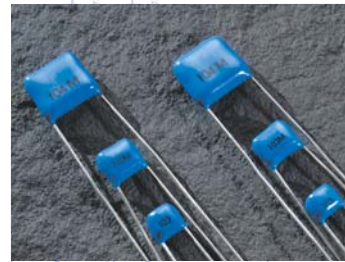

**Radial Leaded**

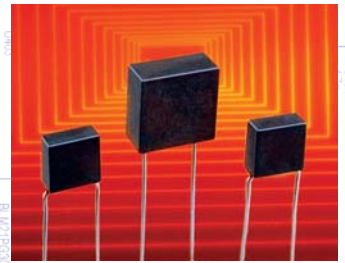

**High Temperature**

1. power supply, 5-12V  
 2. power supply 0V  
 3. lay coil positive  
 4. lay coil negative  
 5. output measure input, 0-100V  
 6. output measure input, 0-100V  
 Comment:  
 USER\_01  
 USER\_02  
 USER\_03  
 USER\_04  
 USER\_05  
 USER\_06  
 USER\_07  
 USER\_08  
 USER\_09  
 USER\_10  
 USER\_11  
 USER\_12  
 USER\_13  
 USER\_14  
 USER\_15  
 USER\_16  
 USER\_17  
 USER\_18  
 USER\_19  
 USER\_20

# Your Technology Partner



The mission of the Johanson Companies is to translate our customer needs into quality electronic components, produced in factories that are models of excellence, supported by innovative service. With over 30 years of experience, Johanson Dielectrics provides both standard and custom technology solutions tailored to your specific electronic applications.

Our standard product range includes High Voltage and AC Safety Capacitors providing solutions for Lighting, IT and Business Equipment designs. Our X2Y<sup>®</sup> Capacitor line provides advanced EMI filtering and IC decoupling solutions and our High Capacitance Tanceram<sup>®</sup> products provide the highest capacitance values in the smallest cases sizes.

## HIGH FREQUENCY CERAMIC SOLUTIONS

are offered by our sister company, Johanson Technology Inc., Camarillo CA. Products include High Q Capacitors, Ceramic and Wire-wound Chip Inductors, and a broad range of LTCC based RF IPCs such as Antennas, Filters, Baluns, Couplers, Matched Filter Baluns, etc.

[www.johansontechnology.com](http://www.johansontechnology.com)

Customized solutions in the areas of High Temperature and High AC power ceramic capacitors are available to customers who require a partnered technology solution.

Johanson Dielectrics design and manufacturing operations are located in Sylmar, California and Zhoaqing, PRC. Our quality minded management system utilizes continuous improvement programs focused on increased product reliability, manufacturing throughput, and product performance. Our broad experience, applications support, and responsive service enhance our ability to drive down your total cost of procurement and speed your time to market.



*Johanson Dielectrics, Inc. reserves the right to make design and price changes without notice. All sales are subject to the terms and conditions printed on the back side of our sales order acknowledgment forms, including a limited warranty and remedies for non-conforming goods or defective goods. We will be pleased to provide a copy of these terms and conditions for your review.*



[www.johansondielectrics.com](http://www.johansondielectrics.com)

## SURFACE MOUNT CERAMIC CAPACITORS

|   |       |
|---|-------|
| Ceramic Capacitor Prototyping Kits                | 4-5   |
| High Voltage Capacitors 250 - 6,000 VDC           | 6-7   |
| Safety Capacitors 250 VAC, Y2, Y3, Japan Standard | 8-9   |
| Low Inductance X2Y <sup>®</sup> Capacitors        | 10-13 |
| Low Inductance Capacitors                         | 14    |
| Chip Feedthru Filter Capacitors                   | 15    |
| High Power AC Capacitors                          | 16    |
| High Temperature - 200°C Capacitors               | 17    |
| High Capacitance Tanceram <sup>®</sup> Capacitors | 18-19 |
| SMT Multi-layer Ceramic Capacitors 10 - 200 VDC   | 20-21 |

## LEADED CERAMIC CAPACITORS

|   |       |
|---|-------|
| SMPS Stacked Capacitors, 125°C & 200°C versions                     | 22-23 |
| Mini-SMPS Stacked Capacitors  | 24-25 |
| Maxi-Cap <sup>™</sup> SMPS Capacitors                               | 26-27 |
| X2Y <sup>®</sup> Low ESL SMPS Stacked Capacitors                    | 28-29 |
| Switch-mode Radial Leaded Capacitors                                | 30-31 |
| High Voltage Radial Leaded Capacitors, 125°C, 200°C, 250°C versions | 32-33 |
| Part Number, Dielectric, Packaging Specifications                   | 34-35 |

### ON-LINE PRODUCTS

N2200 Chip Capacitors  
200°C Radial Leaded Capacitors  
Tin-Lead Termination Capacitors  
Polyterm<sup>®</sup> Termination Capacitors  
Large Size Multi-layer Ceramic Capacitors  
X2Y Filter Eval. & PCB Design Guide

### ON-LINE INFORMATION

Dielectric Characteristics  
Packaging & Marking  
Environmental Compliance Policies  
Lead-Free Reflow Processing  
High Voltage PCB Design  
Capacitor Power Handling



# CERAMIC CAPACITOR ENGINEERING DESIGN KITS

Johanson Dielectrics, Inc. offers a variety of multi-layer chip capacitor sample kits for proto-type design work. Each kit is grouped by type, size, or voltage and contains a selection of popular values and tolerances. The chips are individually packaged in labeled plastic compartments for easy access. The general range of kit contents is described below. Specific part number details may be found at [JohansonDielectrics.com](http://JohansonDielectrics.com)



| 0402 CERAMIC CHIP CAPACITOR KIT                                     |                  |              |                  |             | P/N: S-0402 |
|---|------------------|--------------|------------------|-------------|-------------|
| 1400 piece sample assortment of selected values from 1.0pF to 0.1µF |                  |              |                  |             |             |
| Chip Size   | Voltage Rating   | Dielectric   | Capacitanc Range | Qty / Value | Total Qty   |
| 0402  | 50 VDC - 6.3 VDC | NPO, X7R,Y5V | 1.0pF to 0.22µF  | 50 pcs      | 1400 pcs    |

| 0603 CERAMIC CHIP CAPACITOR KIT                                     |                 |              |                  |             | P/N: S-0603 |
|---|-----------------|--------------|------------------|-------------|-------------|
| 1400 piece sample assortment of selected values from 1.0pF to 0.1µF |                 |              |                  |             |             |
| Chip Size   | Voltage Rating  | Dielectric   | Capacitanc Range | Qty / Value | Total Qty   |
| 0603  | 50 VDC - 16 VDC | NPO, X7R,Y5V | 10pF to 0.22µF   | 50 pcs      | 1400 pcs    |

| 0805 CERAMIC CHIP CAPACITOR KIT                                     |                  |            |                  |             | P/N: S-0805 |
|---|------------------|------------|------------------|-------------|-------------|
| 1400 piece sample assortment of selected values from 1.0pF to 0.1µF |                  |            |                  |             |             |
| Chip Size   | Voltage Rating   | Dielectric | Capacitanc Range | Qty / Value | Total Qty   |
| 0805  | 100 VDC - 16 VDC | NPO, X7R   | 10pF to 0.47µF   | 50 pcs      | 1400 pcs    |

| TANCERAM® HIGH CAPACITANCE CERAMIC CHIP CAPACITOR KIT              |                  |            |                  |             | P/N: S-TAN-X5R |
|--|------------------|------------|------------------|-------------|----------------|
| 500 piece sample assortment of selected values from 1.0µF to 100µF |                  |            |                  |             |                |
| Chip Size  | Voltage Rating   | Dielectric | Capacitanc Range | Qty / Value | Total Qty      |
| 0402, 0603, 0805<br>1206, 1210                                     | 25 VDC - 6.3 VDC | X5R        | 1.0µF - 100µF    | 10 - 25 pcs | 500 pcs        |

| 500 VDC CERAMIC CHIP CAPACITOR KIT                                |                |            |                  |             | P/N: S-500 |
|---|----------------|------------|------------------|-------------|------------|
| 400 piece sample assortment of selected values from 33pF to 0.1µF |                |            |                  |             |            |
| Chip Size   | Voltage Rating | Dielectric | Capacitanc Range | Qty / Value | Total Qty  |
| 0805 - 1812   | 500 VDC        | NPO, X7R   | 33pF to 0.1µF    | 10-20 pcs   | 400 pcs    |

| 1000 VDC CERAMIC CHIP CAPACITOR KIT                               |                |            |                  |             | P/N: S-1KV |
|---|----------------|------------|------------------|-------------|------------|
| 400 piece sample assortment of selected values from 22pF to 0.1µF |                |            |                  |             |            |
| Chip Size   | Voltage Rating | Dielectric | Capacitanc Range | Qty / Value | Total Qty  |
| 0805 - 2225   | 1000 VDC       | NPO, X7R   | 22pF to 0.1µF    | 10-20 pcs   | 400 pcs    |

*Johanson may from time-time adjust actual kit contents based on design demand trends. Check the Johanson web site for design kit updates and kit content changes.*



| 2000 VDC CERAMIC CHIP CAPACITOR KIT                                 |                |            |                  |             | P/N: S-2KV |
|---|----------------|------------|------------------|-------------|------------|
| 300 piece sample assortment of selected values from 22pF to 0.022μF |                |            |                  |             |            |
| Chip Size   | Voltage Rating | Dielectric | Capacitanc Range | Qty / Value | Total Qty  |
| 1206 - 2225   | 2000 VDC       | NPO, X7R   | 22pF to 0.022μF  | 10-20 pcs   | 300 pcs    |

| X2/Y3 SAFETY CERTIFIED CERAMIC CHIP CAPACITOR KIT                   |                 |            |                  |             | P/N: S-SY3 |
|---|-----------------|------------|------------------|-------------|------------|
| 240 piece sample assortment of selected values from 10pF to 1500 pF |                 |            |                  |             |            |
| Chip Size   | Voltage Rating  | Dielectric | Capacitanc Range | Qty / Value | Total Qty  |
| 1808  | 3KV DC / 250 AC | NPO, X7R   | 10pF to 1500 pF  | 20 pcs      | 240 pcs    |

| X1/Y2 SAFETY CERTIFIED CERAMIC CHIP CAPACITOR KIT                   |                 |            |                  |             | P/N: S-SY2 |
|---|-----------------|------------|------------------|-------------|------------|
| 200 piece sample assortment of selected values from 10pF to 2200 pF |                 |            |                  |             |            |
| Chip Size   | Voltage Rating  | Dielectric | Capacitanc Range | Qty / Value | Total Qty  |
| 1808 - 2220   | 5KV DC / 250 AC | NPO, X7R   | 10pF to 2200pF   | 20 pcs      | 200 pcs    |

| X2Y® EMI FILTER CAPACITOR KIT - 0402 SIZE                           |                |            |                  |             | P/N: S-X07CBK |
|---|----------------|------------|------------------|-------------|---------------|
| 600 piece sample assortment of selected values from 1.0pF to 0.01μF |                |            |                  |             |               |
| Chip Size   | Voltage Rating | Dielectric | Capacitanc Range | Qty / Value | Total Qty     |
| 0402  | 10 - 50 VDC    | NPO, X7R   | 1.0pF to 0.01μF  | 50 pcs      | 600 pcs       |

| X2Y® EMI FILTER CAPACITOR KIT - 0603 SIZE                           |                |            |                  |             | P/N: S-X14CBK |
|---|----------------|------------|------------------|-------------|---------------|
| 700 piece sample assortment of selected values from 1.0pF to 0.01μF |                |            |                  |             |               |
| Chip Size   | Voltage Rating | Dielectric | Capacitanc Range | Qty / Value | Total Qty     |
| 0603  | 50 - 100 VDC   | NPO, X7R   | 1.0pF to 0.01μF  | 50 pcs      | 700 pcs       |

| X2Y® POWER BYPASS CAPACITOR KIT - 0603 SIZE                        |                |            |                  |             | P/N: S-X14-PBP |
|--|----------------|------------|------------------|-------------|----------------|
| 300 piece sample assortment of selected values from 1.0nF to 1.0μF |                |            |                  |             |                |
| Chip Size  | Voltage Rating | Dielectric | Capacitanc Range | Qty / Value | Total Qty      |
| 0603   | 6.3 - 100 VDC  | X7R, X5R   | 1.0nF to 1.0μF   | 20 pcs      | 300 pcs        |

| X2Y® EMI FILTER CAPACITOR KIT - 0805 SIZE                           |                |            |                  |             | P/N: S-X15-EMI |
|---|----------------|------------|------------------|-------------|----------------|
| 300 piece sample assortment of selected values from 1.0pF to 0.01μF |                |            |                  |             |                |
| Chip Size   | Voltage Rating | Dielectric | Capacitanc Range | Qty / Value | Total Qty      |
| 0805  | 50 - 100 VDC   | NPO, X7R   | 1.0pF to 0.01μF  | 20 pcs      | 300 pcs        |

| X2Y® DC MOTOR FILTER CAPACITOR KIT                                   |                |            |                  |             | P/N: S-X2Y-MTR |
|--|----------------|------------|------------------|-------------|----------------|
| 300 piece sample assortment of selected values from 0.10μF to 0.47μF |                |            |                  |             |                |
| Chip Size  | Voltage Rating | Dielectric | Capacitanc Range | Qty / Value | Total Qty      |
| 1206 - 1812  | 100 VDC        | X7R        | 0.10μF to 0.47μF | 30 pcs      | 300 pcs        |

*Johanson may from time-time adjust actual kit contents based on design demand trends. Check the Johanson web site for design kit updates and kit content changes.*



# HIGH VOLTAGE SURFACE MOUNT MLCCs 250 - 6,000 VDC



These high voltage capacitors feature a special internal electrode design which reduces voltage concentrations by distributing voltage gradients throughout the entire capacitor. This unique design also affords increased capacitance values in a given case size and voltage rating. The capacitors are designed and manufactured to the general requirement of EIA198 and are subjected to a 100% electrical testing making them well suited for a wide variety of telecommunication, commercial, and industrial applications.





## APPLICATIONS

- Analog & Digital Modems
- Lighting Ballast Circuits
- DC-DC Converters
- LAN/WAN Interface
- Voltage Multipliers
- Back-lighting Inverters

**NOW AVAILABLE** with Polyterm® soft termination option for demanding environments & processes. Visit our website for full details.

## CASE SIZE

## CAPACITANCE SELECTION

| JDI /EIA  | Inches | (mm)       | Rated Voltage | NPO Dielectric |         | X7R Dielectric |         |          |
|---|--------|------------|---------------|----------------|---------|----------------|---------|----------|
|   |        |            |               | Minimum        | Maximum | Minimum        | Maximum |          |
| R15/0805<br> | L      | .080 ±.010 | (2.03 ±.25)   | 250 VDC        | -       | -              | 1000 pF | 0.022 µF |
|   | W      | .050 ±.010 | (1.27 ±.25)   | 500 VDC        | 10 pF   | 680 pF         | 1000 pF | 0.010 µF |
|   | T      | .055 Max.  | (1.40)        | 630 VDC        | 10 pF   | 560 pF         | 1000 pF | 6800 pF  |
|   | E/B    | .020 ±.010 | (0.51±.25)    | 1000 VDC       | 10 pF   | 390 pF         | 100 pF  | 4700 pF  |
|   |        |            |               |                |         |                |         |          |
| R18/1206<br> | L      | .125 ±.010 | (3.17 ±.25)   | 250 VDC        | -       | -              | 1000 pF | 0.068 µF |
|   | W      | .062 ±.010 | (1.57 ±.25)   | 500 VDC        | 10 pF   | 1500 pF        | 1000 pF | 0.047 µF |
|   | T      | .067 Max.  | (1.70)        | 630 VDC        | 10 pF   | 1200 pF        | 1000 pF | 0.027 µF |
|   | E/B    | .020 ±.010 | (0.51±.25)    | 1000 VDC       | 10 pF   | 1000 pF        | 100 pF  | 0.018 µF |
|   |        |            |               | 2000 VDC       | 10 pF   | 220 pF         | 100 pF  | 4700 pF  |
|   |        |            |               | 3000 VDC       | 10 pF   | 82 pF          | 100 pF  | 1000 pF  |
| S41/1210<br> | L      | .125 ±.010 | (3.18 ±.25)   | 250 VDC        | -       | -              | 1000 pF | 0.220 µF |
|   | W      | .095 ±.010 | (2.41 ±.25)   | 500 VDC        | 10 pF   | 3900 pF        | 1000 pF | 0.100 µF |
|   | T      | .080 Max.  | (2.03)        | 630 VDC        | 10 pF   | 2700 pF        | 1000 pF | 0.056 µF |
|   | E/B    | .020 ±.010 | (0.51±.25)    | 1000 VDC       | 10 pF   | 1800 pF        | 100 pF  | 0.047 µF |
|   |        |            |               | 2000 VDC       | 10 pF   | 560 pF         | 100 pF  | 3900 pF  |
|   |        |            |               | 3000 VDC       | 10 pF   | 220 pF         | 100 pF  | 2700 pF  |
| R29/1808<br> | L      | .189 ±.010 | (4.80 ±.25)   | 500 VDC        | 10 pF   | 4700 pF        | 1000 pF | 0.100 µF |
|   | W      | .080 ±.010 | (2.03 ±.25)   | 630 VDC        | 10 pF   | 3300 pF        | 1000 pF | 0.068 µF |
|   | T      | .085 Max.  | (2.16)        | 1000 VDC       | 1.0 pF  | 2200 pF        | 100 pF  | 0.047 µF |
|   | E/B    | .020 ±.010 | (0.51±.25)    | 2000 VDC       | 1.0 pF  | 820 pF         | 100 pF  | 8200 pF  |
|   |        |            |               | 3000 VDC       | 1.0 pF  | 470 pF         | 100 pF  | 3900 pF  |
|   |        |            |               | 4000 VDC       | 1.0 pF  | 180 pF         | 100 pF  | 2200 pF  |
|   |        |            |               | 5000 VDC       | 1.0 pF  | 75 pF          | 47 pF   | 1000 pF  |
|   |        |            |               | 6000 VDC       | 1.0 pF  | 75 pF          | 47 pF   | 100 pF   |





Available cap. values include these significant retma values and their multiples: 1.0 1.2 1.5 1.8 2.2 2.7 3.3 3.9 4.7 5.6 6.8 8.2 (1.0 = 1.0, 10, 100, 1000, etc.) Consult factory for non-retma values and sizes or voltages not shown.



# HIGH VOLTAGE SURFACE MOUNT MLCCs 250 - 6,000 VDC

## CASE SIZE

## CAPACITANCE SELECTION

| JDI /EIA   | Inches             | (mm)  | Rated Voltage  | NPO Dielectric     |   | X7R Dielectric |          |          |         |          |
|--|--------------------|---|--|--------------------|---|----------------|----------|----------|---------|----------|
|  |                    |   |  | Minimum            | Maximum   | Minimum        | Maximum  |          |         |          |
| <b>S43 / 1812</b><br> | L<br>W<br>T<br>E/B | .180 ±.010 (4.57 ±.25)<br>.125 ±.010 (3.17 ±.25)<br>.110 Max. (2.80)<br>.025 ±.015 (0.64±.38) | 250 VDC  | -                  | -   | 0.010 µF       | 0.470 µF |          |         |          |
|  |                    |   | 500 VDC  | 100 pF             | 8200 pF   | 1000 pF        | 0.330 µF |          |         |          |
|  |                    |   | 630 VDC  | 100 pF             | 6800 pF   | 1000 pF        | 0.180 µF |          |         |          |
|  |                    |   | 1000 VDC   | 10 pF              | 5600 pF   | 1000 pF        | 0.100 µF |          |         |          |
|  |                    |   | 2000 VDC   | 10 pF              | 1800 pF   | 100 pF         | 0.010 µF |          |         |          |
|  |                    |   | 3000 VDC   | 10 pF              | 1000 pF   | 100 pF         | 6800 pF  |          |         |          |
|  |                    |   | 4000 VDC   | 10 pF              | 390 pF  | 100 pF         | 2200 pF  |          |         |          |
|  |                    |   | 5000 VDC   | 10 pF              | 150 pF  | 100 pF         | 1000 pF  |          |         |          |
|  |                    |   | 6000 VDC   | 10 pF              | 150 pF  | 10 pF          | 680 pF   |          |         |          |
|  |                    |   | <b>S49 / 1825</b><br>   | L<br>W<br>T<br>E/B | .180 ±.010 (4.57 ±.25)<br>.250 ±.010 (6.35 ±.25)<br>.140 Max. (3.56)<br>.025 ±.015 (0.64±.38) | 500 VDC        | 100 pF   | 0.018 µF | 0.01 µF | 1.000 µF |
| 630 VDC  | 100 pF             | 0.015 µF  |  |                    |   | 0.01 µF        | 0.270 µF |          |         |          |
| 1000 VDC   | 10 pF              | 0.012 µF  |  |                    |   | 1000 pF        | 0.047 µF |          |         |          |
| 2000 VDC   | 10 pF              | 5600 pF   |  |                    |   | 100 pF         | 0.022 µF |          |         |          |
| 3000 VDC   | 10 pF              | 2200 pF   |  |                    |   | 100 pF         | 0.010 µF |          |         |          |
| 4000 VDC   | 10 pF              | 1200 pF   |  |                    |   | 100 pF         | 2700 pF  |          |         |          |
| 5000 VDC   | 10 pF              | 390 pF  |  |                    |   | 100 pF         | 1200 pF  |          |         |          |
| 6000 VDC   | 10 pF              | 390 pF  |  |                    |   | 100 pF         | 820 pF   |          |         |          |
| <b>S47 / 2220</b><br> | L<br>W<br>T<br>E/B | .225 ±.015 (5.72 ±.38)<br>.200 ±.015 (5.08 ±.38)<br>.150 Max. (3.81)<br>.025 ±.015 (0.64±.38) |  |                    |   | 500 VDC        | 1000 pF  | 0.018 µF | 0.01 µF | 0.680 µF |
|  |                    |   |  |                    |   | 630 VDC        | 1000 pF  | 0.018 µF | 0.01 µF | 0.470 µF |
|  |                    |   | 1000 VDC   | 100 pF             | 0.015 µF  | 1000 pF        | 0.100 µF |          |         |          |
|  |                    |   | 2000 VDC   | 100 pF             | 5600 pF   | 1000 pF        | 0.047 µF |          |         |          |
|  |                    |   | 3000 VDC   | 10 pF              | 2700 pF   | 100 pF         | 0.015 µF |          |         |          |
|  |                    |   | 4000 VDC   | 10 pF              | 1500 pF   | 100 pF         | 3300 pF  |          |         |          |
|  |                    |   | 5000 VDC   | 10 pF              | 470 pF  | 100 pF         | 2200 pF  |          |         |          |
|  |                    |   | 6000 VDC   | 10 pF              | 470 pF  | 100 pF         | 1500 pF  |          |         |          |
|  |                    |   | <b>S48 / 2225</b><br> | L<br>W<br>T<br>E/B | .225 ±.010 (5.72 ±.25)<br>.255 ±.015 (6.48 ±.38)<br>.160 Max. (4.06)<br>.025 ±.015 (0.64±.38) | 500 VDC        | 1000 pF  | 0.027 µF | 0.01 µF | 1.000 µF |
|  |                    |   |  |                    |   | 630 VDC        | 1000 pF  | 0.022 µF | 0.01 µF | 0.680 µF |
| 1000 VDC   | 100 pF             | 0.018 µF  |  |                    |   | 1000 pF        | 0.220 µF |          |         |          |
| 2000 VDC   | 100 pF             | 8200 pF   |  |                    |   | 1000 pF        | 0.100 µF |          |         |          |
| 3000 VDC   | 10 pF              | 3300 pF   |  |                    |   | 100 pF         | 0.022 µF |          |         |          |
| 4000 VDC   | 10 pF              | 1800 pF   |  |                    |   | 100 pF         | 0.010 µF |          |         |          |
| 5000 VDC   | 10 pF              | 470 pF  |  |                    |   | 100 pF         | 3300 pF  |          |         |          |
| 6000 VDC   | 10 pF              | 470 pF  |  |                    |   | 100 pF         | 1500 pF  |          |         |          |

Available cap. values include these significant retma values and their multiples: 1.0 1.2 1.5 1.8 2.2 2.7 3.3 3.9 4.7 5.6 6.8 8.2 (1.0 = 1.0, 10, 100, 1000, etc.) Consult factory for non-retma values and sizes or voltages not shown.

## ELECTRICAL CHARACTERISTICS

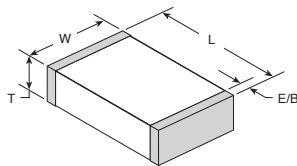

Meets the standard NPO & X7R dielectric specifications listed on page 20

Dielectric Withstanding Voltage

DWV = 1.5 X rated WVDC for ratings ≤ 500 WVDC,

DWV = 1.2 X rated WVDC for ratings ≥ 1,000 WVDC

NOTE: Capacitors may require a surface coating to prevent external arcing. Solder mask should not be used beneath capacitors. For more information see JDI Tech Note "Surface Arc Season"

## HOW TO ORDER HIGH VOLTAGE SURFACE MOUNT

P/N written: 202R18W102KV4E

| 202  | R18  | W                  | 102  | K                                  | V  | 4                            | E  |
|--|--|--------------------|--|------------------------------------|--|------------------------------|--|
| VOLTAGE  | SIZE   | DIELECTRIC         | CAPACITANCE  | TOLERANCE                          | TERMINATION  | MARKING                      | PACKING  |
| 501 = 500 V<br>631 = 630 V<br>102 = 1000 V<br>202 = 2000 V<br>302 = 3000 V<br>402 = 4000 V<br>502 = 5000 V<br>602 = 6000 V | R15=0805<br>R18=1206<br>R29=1808<br>S41=1210<br>S43=1812<br>S47=2220<br>S48=2225<br>S49=1825 | N = NPO<br>W = X7R | 1st two digits are significant; third digit denotes number of zeros.<br>102 = 1000 pF<br>104 = 0.10 µF | J = ± 5%<br>K = ± 10%<br>M = ± 20% | V = Ni Barrier with 100% Sn Plating (Matte)<br><br>F = Polyterm flexible termination<br><br>T = SnPb | 4 = Unmarked<br>6 = EIA Code | E = Embossed 7"<br>T = Punched 7"<br><br>No code = bulk<br><br>Tape specs. per EIA RS481 |



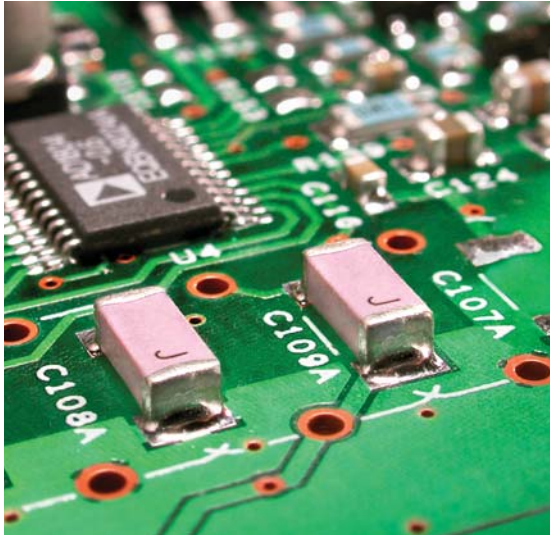

Johanson Dielectrics Type SC ceramic chip capacitors are designed for AC voltage surge and lightning protection in line-to-ground interface applications in computer networks, modem, facsimile and other equipment. Johanson's safety capacitor offering includes four different case sizes and NPO and X7R dielectric materials. These devices are surface mount ready with barrier terminations and tape and reel packaging. Information on capacitor safety ratings and certification details may be found below.

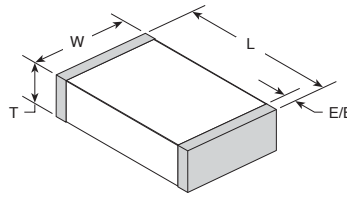

Polyterm® soft termination option available for demanding environments & processes.

| SAFETY RATING  | VOLTAGE RATING | WITHSTANDING VOLTAGE | IMPULSE VOLTAGE | CASE SIZE | JOHANSON ORDERING P/N |
|--|----------------|----------------------|-----------------|-----------|-----------------------|
| X2/Y3  | 250 VAC        | 1,500 VAC            | 2,500 V         | 1808      | 302R29____V3E-****-SC |
| STANDARDS: EN 60384-14:2005, EN 60950 2001 • UL 60950-01 CERTIFICATIONS: TUV Rheinland T72110251 • UL File E212609 • Semko 0026092-1 & 0003222-1   |                |                      |                 |           |                       |
| Y3   | 250 VAC        | 1,500 VAC            | 2,500 V         | 1812      | 302S43____V3E-****-SC |
| STANDARDS: EN 60384-14:2005, EN 60950:2001 CERTIFICATIONS: TUV Rheinland T72110251   |                |                      |                 |           |                       |
| X1/Y2  | 250 VAC        | 1,500 VAC            | 5,000 V         | 1808      | 502R29____V3E-****-SC |
| STANDARDS: EN 60384-14:2005 • UL 60950-01 CERTIFICATIONS: TUV Rheinland T72110897 / UL File E212609-A1-UL-1  |                |                      |                 |           |                       |
| Y2   | 250 VAC        | 1,500 VAC            | 5,000 V         | 2211      | 502R30____V3E-****-SC |
| STANDARDS: EN 60384-14:2005 • UL 60950-01 CERTIFICATIONS: TUV Rheinland T72110897 • UL File: E212609-A1-UL-1   |                |                      |                 |           |                       |
| X1/Y2  | 250 VAC        | 1,500 VAC            | 5,000 V         | 2220      | 502S47____V3E-****-SC |
| STANDARDS: EN 60384-14:2005 • UL 60950-01 CERTIFICATIONS: TUV Rheinland T72110897 • UL File: E212609-A1-UL-1   |                |                      |                 |           |                       |
| Japan  | 250 VAC        | 1,500 VAC            | N/A             | 2220      | AC2____V4E-****-JS    |
| STANDARDS: JIS-C-5102 • JIS-C-5150 CERTIFICATIONS: N/A   |                |                      |                 |           |                       |
| X Capacitors are defined as suitable for use in situations where failure of the capacitor would not lead to danger of electric shock.<br>Y Capacitors are defined as suitable for use in situations where failure of the capacitor could lead to danger of electric shock. |                |                      |                 |           |                       |

## HOW TO ORDER AC SAFETY CAPACITORS





P/N written: 302R29W102MV3E-\*\*\*\*-SC

| 302   | R29  | W                  | 102  | M                                  | V  | 3                           | E  | -****-SC                                   |
|---|--|--------------------|--|------------------------------------|--|-----------------------------|--|--|
| VOLTAGE   | SIZE   | DIELECTRIC         | CAPACITANCE  | TOLERANCE                          | TERMINATION  | MARKING                     | PACKING  | TYPE                                       |
| 302 = 250VAC<br>[3000V Impulse]<br>502 = 250VAC<br>[5000V Impulse]<br>AC2 = 250VAC<br>[N/A] | R29=1808<br>R30=2211<br>S43=1812<br>S47=2220<br>AC2=2220 | N = NPO<br>W = X7R | 1st two digits are significant; third digit denotes number of zeros, R = decimal.<br>102 = 1000 pF<br>104 = 0.10 µF<br>5R0 = 5.0pF | J = ± 5%<br>K = ± 10%<br>M = ± 20% | V = Ni Barrier with 100% Sn Plating (Matte)<br><br>F = Polyterm flexible termination | 3 = Special<br>4 = Unmarked | E = Embossed 7"<br>No code = bulk<br><br>Tape specs. per EIA RS481 | SC = Safety Certified<br>JS = Japan Safety |





## SAFETY CERTIFIED



|  |        |            | 5 pF        | 10 pF | 12 pF | 15 pF | 18 pF | 22 pF | 27 pF | 33 pF | 47 pF | 56 pF | 68 pF | 100 pF | 120 pF | 150 pF | 180 pF | 220 pF | 270 pF | 330 pF | 470 pF | 560 pF | 680 pF | 1000 pF | 1200 pF | 1500 pF | 1800 pF | 2200 pF | 2700 pF | 3300 pF | 4700 pF |  |  |  |  |  |  |
|--|--------|------------|-------------|-------|-------|-------|-------|-------|-------|-------|-------|-------|-------|--------|--------|--------|--------|--------|--------|--------|--------|--------|--------|---------|---------|---------|---------|---------|---------|---------|---------|--|--|--|--|--|--|
| <b>R29 / 1808</b><br><br><b>X2/Y3</b>   | INCHES | (mm)       |             |       |       |       |       |       |       |       |       |       |       |        |        |        |        |        |        |        |        |        |        |         |         |         |         |         |         |         |         |  |  |  |  |  |  |
|  | L      | .189 ±.010 | (4.80 ±.25) |       |       |       |       |       |       |       |       |       |       |        |        |        |        |        |        |        |        |        |        |         |         |         |         |         |         |         |         |  |  |  |  |  |  |
|  | W      | .080 ±.010 | (2.03 ±.25) |       |       |       |       |       |       |       |       |       |       |        |        |        |        |        |        |        |        |        |        |         |         |         |         |         |         |         |         |  |  |  |  |  |  |
|  | T      | .085 Max.  | (2.16)      |       |       |       |       |       |       |       |       |       |       |        |        |        |        |        |        |        |        |        |        |         |         |         |         |         |         |         |         |  |  |  |  |  |  |
|  | E/B    | .020 ±.010 | (0.51±.25)  |       |       |       |       |       |       |       |       |       |       |        |        |        |        |        |        |        |        |        |        |         |         |         |         |         |         |         |         |  |  |  |  |  |  |
| <b>S43 / 1812</b><br><br><b>Y3</b>      | INCHES | (mm)       |             |       |       |       |       |       |       |       |       |       |       |        |        |        |        |        |        |        |        |        |        |         |         |         |         |         |         |         |         |  |  |  |  |  |  |
|  | L      | .175 ±.010 | (4.45 ±.25) |       |       |       |       |       |       |       |       |       |       |        |        |        |        |        |        |        |        |        |        |         |         |         |         |         |         |         |         |  |  |  |  |  |  |
|  | W      | .125 ±.010 | (3.17 ±.25) |       |       |       |       |       |       |       |       |       |       |        |        |        |        |        |        |        |        |        |        |         |         |         |         |         |         |         |         |  |  |  |  |  |  |
|  | T      | .115 Max.  | (2.92)      |       |       |       |       |       |       |       |       |       |       |        |        |        |        |        |        |        |        |        |        |         |         |         |         |         |         |         |         |  |  |  |  |  |  |
|  | E/B    | .025 ±.015 | (0.64±.38)  |       |       |       |       |       |       |       |       |       |       |        |        |        |        |        |        |        |        |        |        |         |         |         |         |         |         |         |         |  |  |  |  |  |  |
| <b>R29 / 1808</b><br><br><b>X1/Y2</b>   | INCHES | (mm)       |             |       |       |       |       |       |       |       |       |       |       |        |        |        |        |        |        |        |        |        |        |         |         |         |         |         |         |         |         |  |  |  |  |  |  |
|  | L      | .189 ±.010 | (4.80 ±.25) |       |       |       |       |       |       |       |       |       |       |        |        |        |        |        |        |        |        |        |        |         |         |         |         |         |         |         |         |  |  |  |  |  |  |
|  | W      | .080 ±.010 | (2.03 ±.25) |       |       |       |       |       |       |       |       |       |       |        |        |        |        |        |        |        |        |        |        |         |         |         |         |         |         |         |         |  |  |  |  |  |  |
|  | T      | .085 Max.  | (2.16)      |       |       |       |       |       |       |       |       |       |       |        |        |        |        |        |        |        |        |        |        |         |         |         |         |         |         |         |         |  |  |  |  |  |  |
|  | E/B    | .012 ±.005 | (0.30±.13)  |       |       |       |       |       |       |       |       |       |       |        |        |        |        |        |        |        |        |        |        |         |         |         |         |         |         |         |         |  |  |  |  |  |  |
| <b>R30 / 2211</b><br><br><b>Y2</b>      | INCHES | (mm)       |             |       |       |       |       |       |       |       |       |       |       |        |        |        |        |        |        |        |        |        |        |         |         |         |         |         |         |         |         |  |  |  |  |  |  |
|  | L      | .225 ±.016 | (5.72 ±.40) |       |       |       |       |       |       |       |       |       |       |        |        |        |        |        |        |        |        |        |        |         |         |         |         |         |         |         |         |  |  |  |  |  |  |
|  | W      | .110 ±.010 | (2.80 ±.25) |       |       |       |       |       |       |       |       |       |       |        |        |        |        |        |        |        |        |        |        |         |         |         |         |         |         |         |         |  |  |  |  |  |  |
|  | T      | .115 Max.  | (2.92)      |       |       |       |       |       |       |       |       |       |       |        |        |        |        |        |        |        |        |        |        |         |         |         |         |         |         |         |         |  |  |  |  |  |  |
|  | E/B    | .020 ±.010 | (0.51±.25)  |       |       |       |       |       |       |       |       |       |       |        |        |        |        |        |        |        |        |        |        |         |         |         |         |         |         |         |         |  |  |  |  |  |  |
| <b>S47 / 2220</b><br><br><b>X1/Y2</b> | INCHES | (mm)       |             |       |       |       |       |       |       |       |       |       |       |        |        |        |        |        |        |        |        |        |        |         |         |         |         |         |         |         |         |  |  |  |  |  |  |
|  | L      | .225 ±.015 | (5.72 ±.38) |       |       |       |       |       |       |       |       |       |       |        |        |        |        |        |        |        |        |        |        |         |         |         |         |         |         |         |         |  |  |  |  |  |  |
|  | W      | .200 ±.015 | (5.08 ±.38) |       |       |       |       |       |       |       |       |       |       |        |        |        |        |        |        |        |        |        |        |         |         |         |         |         |         |         |         |  |  |  |  |  |  |
|  | T      | .150 Max.  | (3.81)      |       |       |       |       |       |       |       |       |       |       |        |        |        |        |        |        |        |        |        |        |         |         |         |         |         |         |         |         |  |  |  |  |  |  |
|  | E/B    | .025 ±.015 | (0.64±.38)  |       |       |       |       |       |       |       |       |       |       |        |        |        |        |        |        |        |        |        |        |         |         |         |         |         |         |         |         |  |  |  |  |  |  |

**DIELECTRIC**

NPO

X7R

## JAPAN STANDARD

|   |        |            | 470pF       | 1000pF | 2200pF | 3300pF | 4700pF | 0.01µF | 0.022µF | 0.047µF | 0.10µF |  |
|---|--------|------------|-------------|--------|--------|--------|--------|--------|---------|---------|--------|--|
| <b>J29 / 1808</b><br><br><b>Japan Safety</b> | INCHES | (mm)       |             |        |        |        |        |        |         |         |        |  |
|   | L      | .189 ±.010 | (4.80 ±.25) |        |        |        |        |        |         |         |        |  |
|   | W      | .080 ±.010 | (2.03 ±.25) |        |        |        |        |        |         |         |        |  |
|   | T      | .085 Max.  | (2.16)      |        |        |        |        |        |         |         |        |  |
|   | E/B    | .020 ±.010 | (0.51±.25)  |        |        |        |        |        |         |         |        |  |
| <b>J43 / 1812</b><br><br><b>Japan Safety</b> | INCHES | (mm)       |             |        |        |        |        |        |         |         |        |  |
|   | L      | .175 ±.010 | (4.45 ±.25) |        |        |        |        |        |         |         |        |  |
|   | W      | .125 ±.010 | (3.17 ±.25) |        |        |        |        |        |         |         |        |  |
|   | T      | .115 Max.  | (2.92)      |        |        |        |        |        |         |         |        |  |
|   | E/B    | .025 ±.015 | (0.64±.38)  |        |        |        |        |        |         |         |        |  |
| <b>J47 / 2220</b><br><br><b>Japan Safety</b> | INCHES | (mm)       |             |        |        |        |        |        |         |         |        |  |
|   | L      | .225 ±.015 | (5.72 ±.38) |        |        |        |        |        |         |         |        |  |
|   | W      | .200 ±.015 | (5.08 ±.38) |        |        |        |        |        |         |         |        |  |
|   | T      | .150 Max.  | (3.81)      |        |        |        |        |        |         |         |        |  |
|   | E/B    | .025 ±.015 | (0.64±.38)  |        |        |        |        |        |         |         |        |  |

# X2Y® FILTER & DECOUPLING CAPACITORS

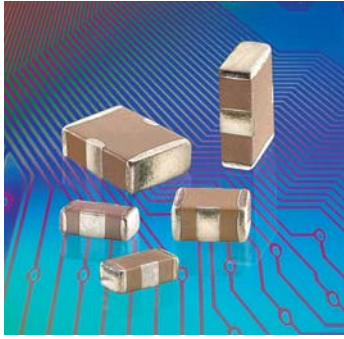

X2Y® filter capacitors employ a unique, patented low inductance design featuring two balanced capacitors that are immune to temperature, voltage and aging performance differences. These components offer superior decoupling and EMI filtering performance, virtually eliminate parasitics, and can replace multiple capacitors and inductors saving board space and reducing assembly costs.

## ADVANTAGES

- One device for EMI suppression or decoupling
- Replace up to 7 components with one X2Y
- Differential and common mode attenuation
- Matched capacitance line to ground, both lines
- Low inductance due to cancellation effect

## APPLICATIONS

- Amplifier Filter & Decoupling
- High Speed Data Filtering
- EMC I/O Filtering
- FPGA / ASIC /  $\mu$ -P Decoupling
- DDR Memory Decoupling

| EMI Filtering (1 Y-Cap.) |           | <10pF | 10pF | 22pF | 27pF | 33pF | 47pF | 100pF | 220pF | 470pF | 1000pF | 1500pF | 2200pF | 4700pF | .010 $\mu$ F | .015 $\mu$ F | .022 $\mu$ F | .039 $\mu$ F | .047 $\mu$ F | 0.10 $\mu$ F | 0.18 $\mu$ F | 0.22 $\mu$ F | 0.33 $\mu$ F | 0.40 $\mu$ F | 0.47 $\mu$ F | 1.0 $\mu$ F |  |
|--------------------------|-----------|-------|------|------|------|------|------|-------|-------|-------|--------|--------|--------|--------|--------------|--------------|--------------|--------------|--------------|--------------|--------------|--------------|--------------|--------------|--------------|-------------|--|
| Power Bypass (2 Y-Caps.) |           | <20pF | 20pF | 44pF | 54pF | 66pF | 94pF | 200pF | 440pF | 940pF | 2000pF | 3000pF | 4400pF | 9400pF | .020 $\mu$ F | .030 $\mu$ F | .044 $\mu$ F | .078 $\mu$ F | .094 $\mu$ F | 0.20 $\mu$ F | 0.36 $\mu$ F | 0.44 $\mu$ F | 0.68 $\mu$ F | 0.80 $\mu$ F | 0.94 $\mu$ F | 2.0 $\mu$ F |  |
| SIZE                     | CAP. CODE | XRX   | 100  | 220  | 270  | 330  | 470  | 101   | 221   | 471   | 102    | 152    | 222    | 472    | 103          | 153          | 223          | 393          | 473          | 104          | 184          | 224          | 334          | 404          | 474          | 105         |  |
| 0402 (X07)               | NPO       | 50    | 50   | 50   | 50   | 50   | 50   |       |       |       |        |        |        |        |              |              |              |              |              |              |              |              |              |              |              |             |  |
|                          | X7R       |       |      |      |      |      |      |       | 50    | 50    | 50     | 50     | 50     | 50     | 16           |              |              |              |              |              |              |              |              |              |              |             |  |
| 0603 (X14)               | NPO       | 100   | 100  | 100  | 100  | 100  | 50   | 50    | 50    |       |        |        |        |        |              |              |              |              |              |              |              |              |              |              |              |             |  |
|                          | X7R       |       |      |      |      |      | 100  | 100   | 100   | 100   | 100    | 100    | 100    | 100    | 50           | 25           | 25           |              | 16           | 10           |              | 6.3          |              |              |              |             |  |
|                          | X5R       |       |      |      |      |      |      |       |       |       |        |        |        |        |              |              |              |              |              |              |              | 16           | 10           |              | 10           | 10          |  |
| 0805 (X15)               | NPO       |       | 100  | 100  | 100  | 100  | 100  | 100   | 100   | 50    |        |        |        |        |              |              |              |              |              |              |              |              |              |              |              |             |  |
|                          | X7R       |       |      |      |      |      |      | 100   | 100   | 100   | 100    | 100    | 100    | 100    | 100          | 50           | 50           |              | 50           | 25           | 10           |              |              |              |              |             |  |
| 1206 (X18)               | NPO       |       |      |      |      |      |      |       |       |       | 100    |        |        |        |              |              |              |              |              |              |              |              |              |              |              |             |  |
|                          | X7R       |       |      |      |      |      |      |       |       |       |        |        |        |        | 100          | 100          | 100          |              | 100          | 100          |              | 16           | 16           |              | 10           |             |  |
| 1210 (X41)               | X7R       |       |      |      |      |      |      |       |       |       |        |        |        |        | 500          |              |              |              | 100          |              | 100          | 100          |              | 25           | 16           |             |  |
| 1410 (X44)               | X7R       |       |      |      |      |      |      |       |       |       |        |        |        |        |              | 500          |              |              |              |              |              |              |              | 100          |              |             |  |
| 1812 (X43)               | X7R       |       |      |      |      |      |      |       |       |       |        |        |        |        |              |              |              | 500          |              |              |              |              |              |              | 100          |             |  |

Contact factory for part combinations not shown.  
Filtering capacitance is specified as Line-to-Ground ( Terminal A or B to G) Power Bypass capacitance is specified Power-to-Ground (A + B to G)  
Rated voltage is from line to ground in Circuit 1, power to ground in Circuit 2 .

## HOW TO ORDER X2Y® FILTER & DECOUPLING CAPACITORS

P/N written: 101X14W102MV4T

| 100   | X14  | W                             | 102   | M  | V   | 4                               | T  |
|---|--|-------------------------------|---|--|---|---------------------------------|--|
| VOLTAGE   | SIZE   | DIELECTRIC                    | CAPACITANCE   | TOLERANCE  | TERMINATION   | MARKING                         | PACKING  |
| 6R3 = 6.3 V<br>100 = 10 V<br>160 = 16 V<br>250 = 25 V<br>500 = 50 V<br>101 = 100 V<br>501 = 500 V | X07=0402<br>X14=0603<br>X15=0805<br>X18=1206<br>X41=1210<br>X44=1410<br>X43=1812 | N = NPO<br>W = X7R<br>X = X5R | 1st two digits are significant; third digit denotes number of zeros, R = decimal.<br>102 = 1000 pF<br>104 = 0.10 $\mu$ F<br>5R6 = 5.6pF | M = $\pm$ 20%<br>* D = $\pm$ 0.50 pF<br>*Values < 10 pF only | V = Ni Barrier with 100% Tin Plating (Matte)<br>F = Polyterm flexible termination<br>T = SnPb | 4 = Unmarked<br>(Not available) | E = Embossed 7"<br>T = Punched 7"<br>No code = bulk<br>Tape specs. per EIA RS481 |

X2Y® technology patents and registered trademark under license from X2Y ATTENUATORS, LLC



## EMI Filtering S21 Signal-to-Ground

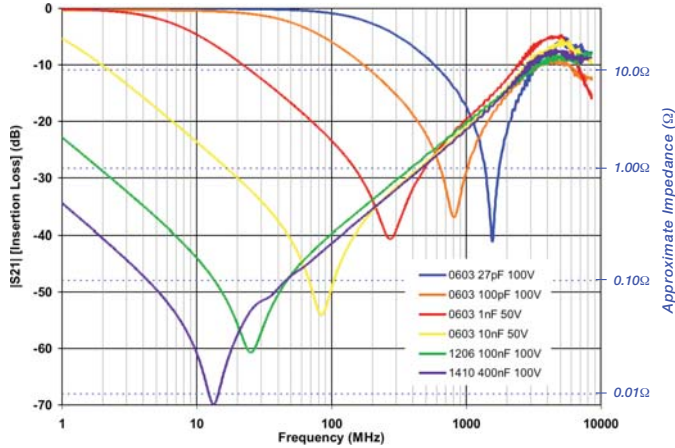
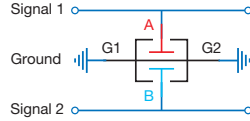

## Power Bypass S21 Power-to-Ground

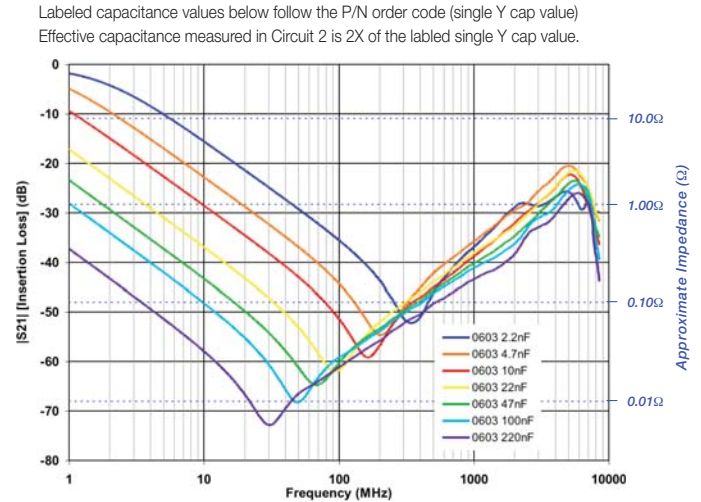
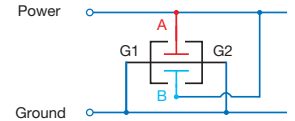

Labeled capacitance values below follow the P/N order code (single Y cap value)  
Effective capacitance measured in Circuit 2 is 2X of the labeled single Y cap value.

## ELECTRICAL CHARACTERISTICS

|   | NPO  | X7R   | X5R   |
|---|--|---|---|
| Temperature Coefficient:                  | ±15% (-55 to +125°C)   | ±15% (-55 to +125°C)  | ±15% (-55 to +85°C)                               |
| Dielectric Strength:                      | Rated ≤100VDC: DWV = 2.5 X WVDC, 25°C, 50mA max.   |   | Rated = 500VDC: DWV = 1.5 X WVDC, 25°C, 50mA max. |
| Dissipation Factor:                       | 0.1% max.  | WVDC ≥ 50 VDC: 2.5% max.<br>WVDC = 25 VDC: 3.5% max.<br>WVDC = 10-16 VDC: 5.0% max.<br>WVDC = 6.3 VDC: 10% max. | WVDC ≥ 50 VDC: 5% max.<br>WVDC ≤ 25 VDC: 10% max. |
| Insulation Resistance (Min. @ 25°C, WVDC) | C ≤ 0.047μF: 1000 ΩF or 100 GΩ, whichever is less<br>C > 0.047μF: 500 ΩF or 10 GΩ, whichever is less |   |   |
| Test Conditions:                          | C > 100 pF; 1kHz ±50Hz; 1.0±0.2 VRMS<br>C ≤ 100 pF; 1Mhz ±50kHz; 1.0±0.2 VRMS                        | 1.0kHz±50Hz @ 1.0±0.2 Vrms  |   |
| Other:                                    | See main catalog page 35 for additional dielectric specifications.                                   |   |   |

### Equivalent Circuits

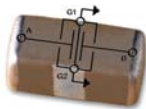
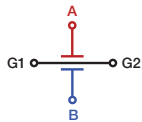

### Cross-sectional View

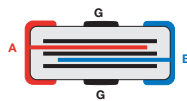

### Dimensional View

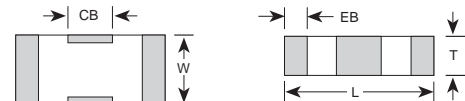

## CASE SIZE

|    | 0402 (X07)    |               | 0603 (X14)    |               | 0805 (X15)    |               | 1206 (X18)    |               | 1210 (X41)    |               | 1410 (X44)    |               | 1812 (X43)    |               |
|----|---------------|---------------|---------------|---------------|---------------|---------------|---------------|---------------|---------------|---------------|---------------|---------------|---------------|---------------|
|    | IN            | mm            | IN            | mm            | IN            | mm            | IN            | mm            | IN            | mm            | IN            | mm            | IN            | mm            |
| L  | 0.045 ± 0.003 | 1.143 ± 0.076 | 0.064 ± 0.005 | 1.626 ± 0.127 | 0.080 ± 0.008 | 2.032 ± 0.203 | 0.124 ± 0.010 | 3.150 ± 0.254 | 0.125 ± 0.010 | 3.175 ± 0.254 | 0.140 ± 0.010 | 3.556 ± 0.254 | 0.174 ± 0.010 | 4.420 ± 0.254 |
| W  | 0.025 ± 0.003 | 0.635 ± 0.076 | 0.035 ± 0.005 | 0.889 ± 0.127 | 0.050 ± 0.008 | 1.270 ± 0.203 | 0.063 ± 0.010 | 1.600 ± 0.254 | 0.098 ± 0.010 | 2.489 ± 0.254 | 0.098 ± 0.010 | 2.490 ± 0.254 | 0.125 ± 0.010 | 3.175 ± 0.254 |
| T  | 0.020 max     | 0.508 max     | 0.026 max     | 0.660 max     | 0.040 max     | 1.016 max     | 0.050 max     | 1.270 max     | 0.070 max     | 1.778 max     | 0.070 max     | 1.778 max     | 0.090 max     | 2.286 max     |
| EB | 0.008 ± 0.003 | 0.203 ± 0.076 | 0.010 ± 0.006 | 0.254 ± 0.152 | 0.012 ± 0.008 | 0.305 ± 0.203 | 0.016 ± 0.010 | 0.406 ± 0.254 | 0.018 ± 0.010 | 0.457 ± 0.254 | 0.018 ± 0.010 | 0.457 ± 0.254 | 0.022 ± 0.012 | 0.559 ± 0.305 |
| CB | 0.012 ± 0.003 | 0.305 ± 0.076 | 0.018 ± 0.004 | 0.457 ± 0.102 | 0.022 ± 0.005 | 0.559 ± 0.127 | 0.040 ± 0.005 | 1.016 ± 0.127 | 0.045 ± 0.005 | 1.143 ± 0.127 | 0.045 ± 0.005 | 1.143 ± 0.127 | 0.045 ± 0.005 | 1.143 ± 0.127 |



## The X2Y® Design - A Balanced, Low ESL, “Capacitor Circuit”

The X2Y® capacitor design starts with standard 2 terminal MLC capacitor’s opposing electrode sets, A & B, and adds a third electrode set (G) which surround each A & B electrode. The result is a highly versatile three node capacitive circuit containing two tightly matched, low inductance capacitors in a compact, four-terminal SMT chip.

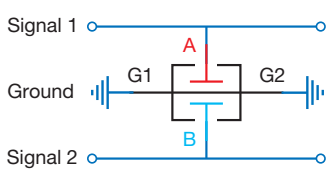
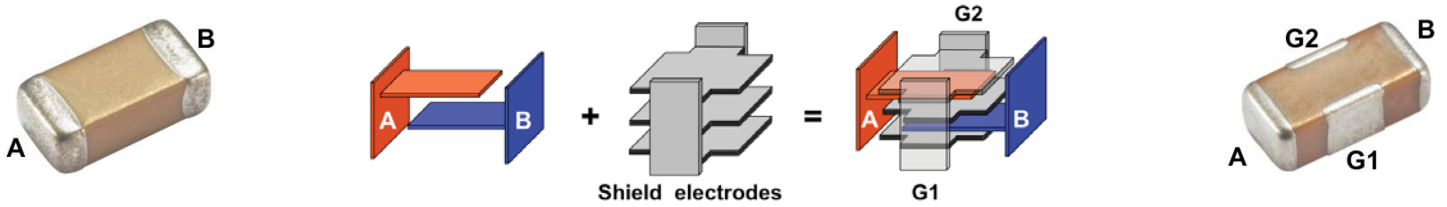

### EMI Filtering:

The X2Y® component contains two shunt or “line-to-ground” Y capacitors. Ultra-low ESL (equivalent series inductance) and tightly matched inductance of these capacitors provides unequalled high frequency Common-Mode noise filtering with low noise mode conversion. X2Y® components reduce EMI emissions far better than unbalanced discrete shunt capacitors or series inductive filters. Differential signal loss is determined by the cut off frequency of the single line-to-ground (Y) capacitor value of an X2Y.

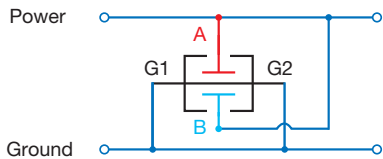

### Power Bypass / Decoupling

For Power Bypass applications, X2Ys® two “Y” capacitors are connected in parallel. This doubles the total capacitance and reduces their mounted inductance by 80% or 1/5th the mounted inductance of similar sized MLC capacitors enabling high-performance bypass networks with far fewer components and vias. Low ESL delivers improved High Frequency performance into the GHz range.

## GSM RFI Attenuation in Audio & Analog

GSM handsets transmit in the 850 and 1850 MHz bands using a TDMA pulse rate of 217Hz. These signals cause the GSM buzz heard in a wide range of audio products from headphones to concert hall PA systems or “silent” signal errors created in medical, industrial process control, and security applications. Testing was conducted where an 840MHz GSM handset signal was delivered to the inputs of three different amplifier test circuit configurations shown below whose outputs were measured on a HF spectrum analyzer.

- 1) No input filter, 2 discrete MLC 100nF power bypass caps.
- 2) 2 discrete MLC 1nF input filter, 2 discrete MLC 100nF power bypass caps.
- 3) A single X2Y 1nF input filter, a single X2Y 100nF power bypass cap.

X2Y configuration provided a nearly flat response above the ambient and up to 10 dB improved rejection than the conventional MLCC configuration.

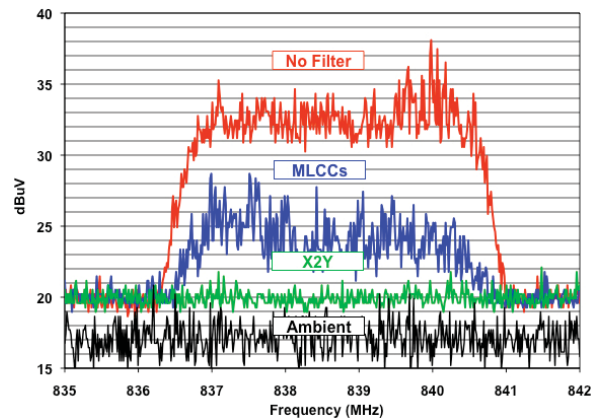

## Amplifier Input Filter Example

In this example, a single Johanson X2Y® component was used to filter noise at the input of a DC instrumentation amplifier. This reduced component count by 3-to-1 and costs by over 70% vs. conventional filter components that included 1% film Y-capacitors.

| Parameter             | X2Y®<br>10nF  | Discrete<br>10nF, 2 @ 220 pF | Comments          |
|-----------------------|---------------|------------------------------|-------------------|
| DC offset shift       | < 0.1 $\mu$ V | < 0.1 $\mu$ V                | Referred to input |
| Common mode rejection | 91 dB         | 92 dB                        |                   |

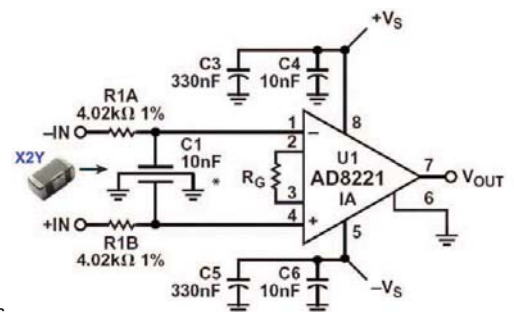

Source: Analog Devices, “A Designer’s Guide to Instrumentation Amplifiers (2nd Edition)” by Charles Kitchin and Lew Counts

## Common Mode Choke Replacement

- Superior High Frequency Emissions Reduction
- Smaller Sizes, Lighter Weight
- No Current Limitation
- Vibration Resistant
- No Saturation Concerns

See our website for a detailed application note with component test comparisons and circuit emissions measurements.

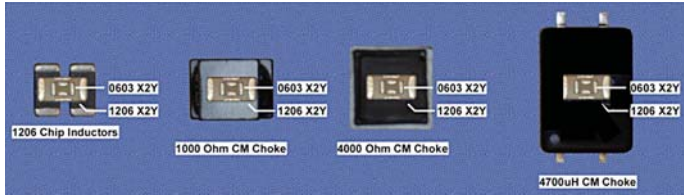

## Measured Common Mode Rejection

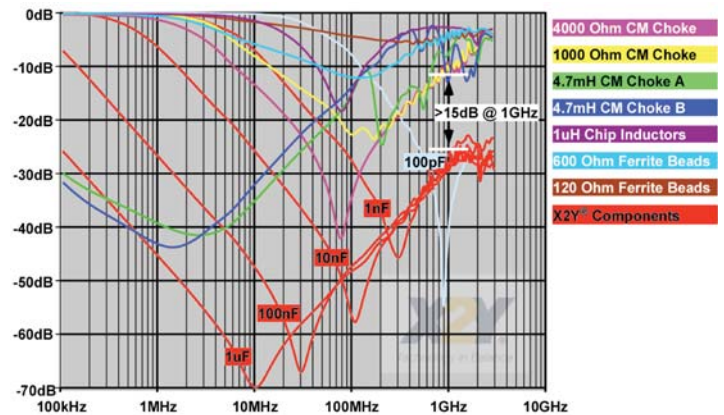

## Parallel Capacitor Solution

A common design practice is to parallel decade capacitance values to extend the high frequency performance of the filter network. This causes an unintended and often over-looked effect of anti-resonant peaks in the filter networks combined impedance. X2Y's very low mounted inductance allows designers to use a single, higher value part and completely avoid the anti-resonance problem. The impedance graph on right shows the combined mounted impedance of a 1nF, 10nF & 100nF 0402 MLC in parallel in RED. The MLC networks anti-resonance peaks are nearly 10 times the desired impedance. A 100nF and 47nF X2Y are plotted in BLUE and GREEN. (The total capacitance of X2Y (Circuit 2) is twice the value, or 200nF and 98nF in this example.) The single X2Y is clearly superior to the three paralleled MLCs.

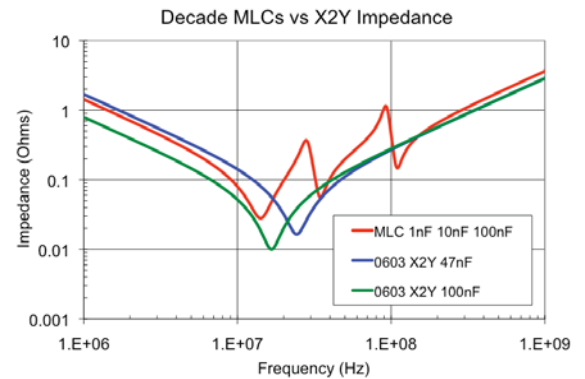

## X2Y High Performance Power Bypass - Improve Performance, Reduce Space & Vias

Actual measured performance of two high performance SerDes FPGA designs demonstrate how a 13 component X2Y bypass network significantly outperforms a 38 component MLC network. For more information see [http://johansondielectrics.com/pdfs/JDI\\_X2Y\\_STXII.pdf](http://johansondielectrics.com/pdfs/JDI_X2Y_STXII.pdf)

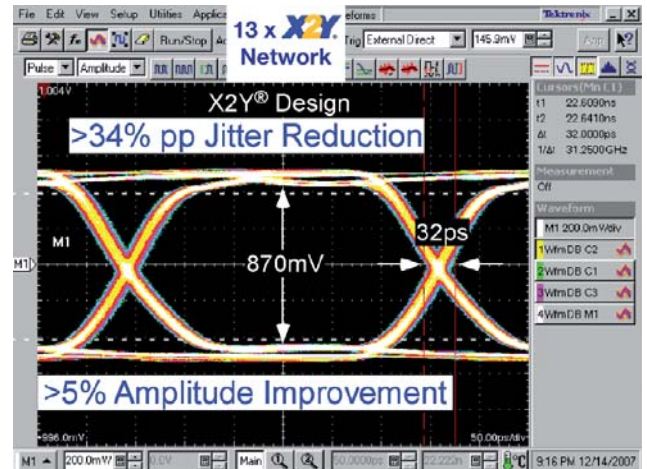
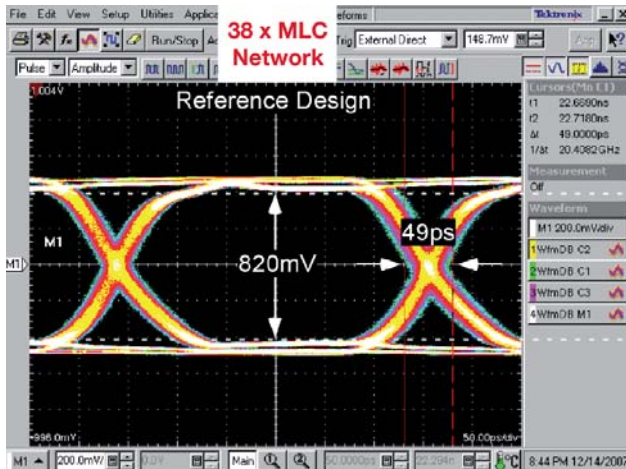
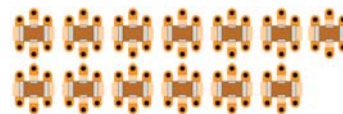
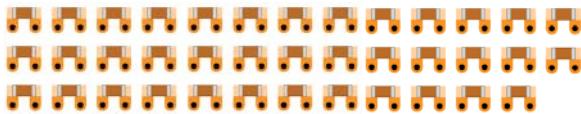

# LOW INDUCTANCE CHIP CAPACITORS (LICC)



LICC capacitors are specially designed to exhibit lower inductance by altering the aspect ratio of the terminations. The smaller current loop length results in Equivalent Series Inductance (ESL) that is typically 60% lower than standard MLCs of the same size. This ESL improvement is extremely advantageous in the high frequency power decoupling of high speed digital MPU, FPGA, DSP, etc..

## FEATURES

- Low Inductance
- High Series Resonant Frequency
- RoHS Compliant
- Sn-Pb and Polyterm® Termination Options
- Surface Mount
- Small Size

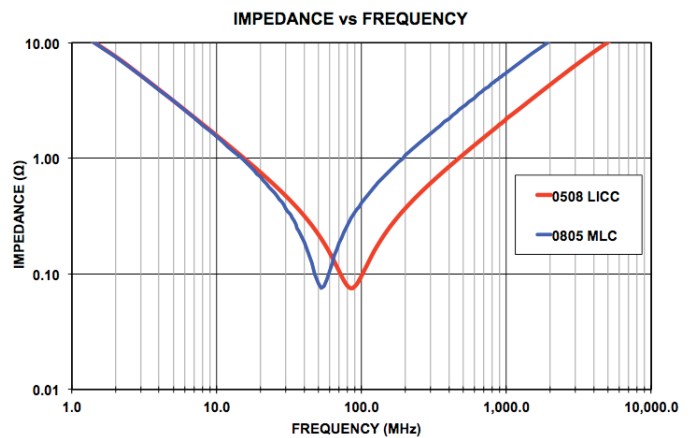
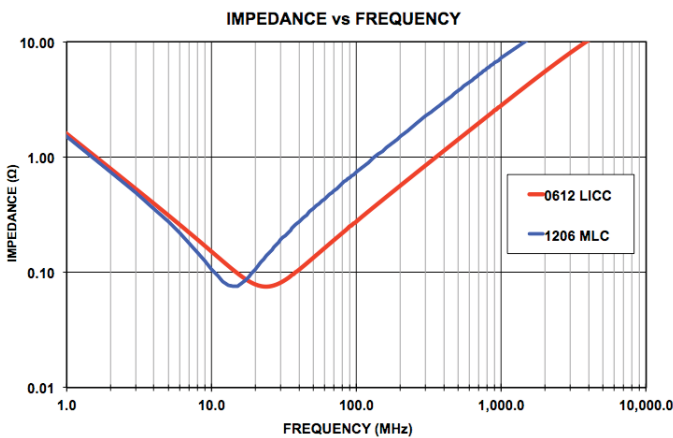
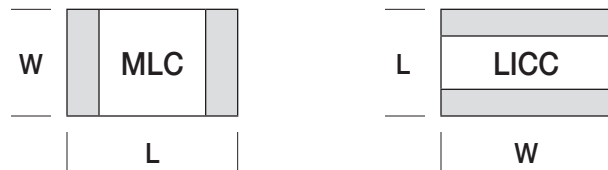

## CASE SIZE

## AVAILABLE CAPACITANCE

|                     | CASE SIZE    |             | Dielectric | AVAILABLE CAPACITANCE |      |      |        |        |        |        |        |       |      |
|---------------------|--------------|-------------|------------|-----------------------|------|------|--------|--------|--------|--------|--------|-------|------|
|                     | Inches       | (mm)        |            | 10nF                  | 22nF | 47nF | 0.10µF | 0.22µF | 0.47µF | 1.00µF | 2.2 µF | 4.7µF | 10µF |
| <b>0306<br/>B14</b> | L .032 ±.008 | (0.81 ±.20) | X7R        | 25V                   | 25V  | 25V  | 16V    | 6.3V   |        |        |        |       |      |
|                     | W .063 ±.008 | (1.60 ±.20) | X5R        |                       |      |      | 10V    | 10V    | 6.3V   | 6.3V   | 6.3V   |       |      |
| <b>0508<br/>B15</b> | L .050 ±.010 | (1.27 ±.25) | X7R        | 50V                   | 50V  | 25V  | 25V    | 16V    | 6.3V   | 6.3V   |        |       |      |
|                     | W .080 ±.010 | (2.03 ±.25) | X5R        |                       |      |      |        |        | 10V    | 10V    | 6.3V   |       |      |
| <b>0612<br/>B18</b> | L .062 ±.010 | (1.57 ±.25) | X7R        | 50V                   | 50V  | 50V  | 50V    | 25V    | 16V    | 6.3V   |        |       |      |
|                     | W .125 ±.010 | (3.17 ±.25) | X5R        |                       |      |      |        |        |        | 10V    | 10V    | 6.3V  | 6.3V |
|                     | T .035 Max.  | (0.90)      |            |                       |      |      |        |        |        |        |        |       |      |
|                     | EB .010±.005 | (0.25±.13)  |            |                       |      |      |        |        |        |        |        |       |      |
|                     |              |             |            |                       |      |      |        |        |        |        |        |       |      |
|                     |              |             |            |                       |      |      |        |        |        |        |        |       |      |

Please visit our website for additional product details and ordering information



# CHIP FILTER / FEED-THRU CAPACITORS



Our Feed-Thru Capacitors provide excellent EMI, I/O & Power Line filtering exhibiting much lower inductance than standard SMT capacitors which results in broader frequency response. These are Precious Metal Electrode (PME) products with higher current ratings than comparable Base Metal Electrode (BME) parts.

## FEATURES

- 1 Amp Current Rating
- Low Inductance, High SRF
- Surface Mount Non-polarized
- Sn-Pb and Polyterm<sup>®</sup> Termination Options

## APPLICATIONS

- DC Power Line EMI Filter
- RF Immunity Filter
- RF Amplifier Gain Filter

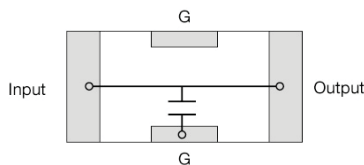

## AVAILABLE CAPACITANCE

| CASE SIZE   |        |             | VDC           | CAPACITANCE |      |       |       |       |       |       |       |      |      |      |       |       |
|-------------|--------|-------------|---------------|-------------|------|-------|-------|-------|-------|-------|-------|------|------|------|-------|-------|
| EIA / JDI   | Inches | (mm)        |               | 22pF        | 47pF | 100pF | 220pF | 470pF | 1.0nF | 2.2nF | 4.7nF | 10nF | 22nF | 47nF | 100nF | 220nF |
| 0603<br>F14 | L      | .064 ± .005 | (1.60 ± 0.20) | 50          | ■    | ■     | ■     |       |       |       |       |      |      |      |       |       |
|             | W      | .035 ± .005 | (0.81 ± 0.20) | 50          | ■    | ■     | ■     |       |       |       |       |      |      |      |       |       |
|             | T      | .026 Max.   | (0.66)        | 50          |      |       |       |       |       |       |       |      |      |      |       |       |
|             | EB     | .009 ± .004 | (0.23 ± 0.10) | 25          |      |       |       |       | ■     | ■     | ■     | ■    | ■    | ■    | ■     | ■     |
| 0805<br>F15 | L      | .080 ± .080 | (2.03 ± 0.25) | 100         | ■    | ■     | ■     | ■     |       |       |       |      |      |      |       |       |
|             | W      | .050 ± .080 | (1.27 ± 0.25) | 100         | ■    | ■     | ■     | ■     |       |       |       |      |      |      |       |       |
|             | T      | .040 Max.   | (1.02)        | 100         |      |       |       |       |       |       |       |      |      |      |       |       |
|             | EB     | .009 ± .004 | (0.23 ± 0.10) | 50          |      |       |       |       | ■     | ■     | ■     | ■    | ■    | ■    | ■     | ■     |
| 1206<br>F18 | L      | .124 ± .010 | (3.15 ± 0.25) | 100         | ■    | ■     | ■     | ■     |       |       |       |      |      |      |       |       |
|             | W      | .063 ± .010 | (1.60 ± 0.25) | 100         | ■    | ■     | ■     | ■     |       |       |       |      |      |      |       |       |
|             | T      | .050 Max.   | (1.27)        | 100         |      |       |       |       |       |       |       |      |      |      |       |       |
|             | EB     | .009 ± .004 | (0.23 ± 0.10) | 50          |      |       |       |       |       | ■     | ■     | ■    | ■    | ■    | ■     | ■     |
| 1206<br>F18 | CB     | .040 ± .005 | (1.02 ± 0.13) | 50          |      |       |       |       |       | ■     | ■     | ■    | ■    | ■    | ■     | ■     |

Please visit our website for additional product details and ordering information



# HIGH VOLTAGE AC POWER CERAMIC CAPACITORS



This capacitor series was developed for applications requiring AC power handling. Because ceramic chips have an MSL (moisture sensitivity level) of 1.0, they exhibit far better lead-free solder reflow performance than competing FILM caps. This series is also available with Polyterm® flexible terminations which increases their resistance to cracking from excessive PCB flexure.

## APPLICATIONS

- Film Cap Replacement
- Florescent and HID Lighting Ballasts
- Industrial Controls • Networking

## TYPICAL POWER RATINGS VS CHIP SIZE

| EIA Size | JDI Size | Rated Power |
|----------|----------|-------------|
| 1206     | R18      | 0.08 W      |
| 1210     | S41      | 0.20 W      |
| 1812     | S43      | 0.40 W      |

TYPICAL RIPPLE CURRENT 1KV 1812 NPO

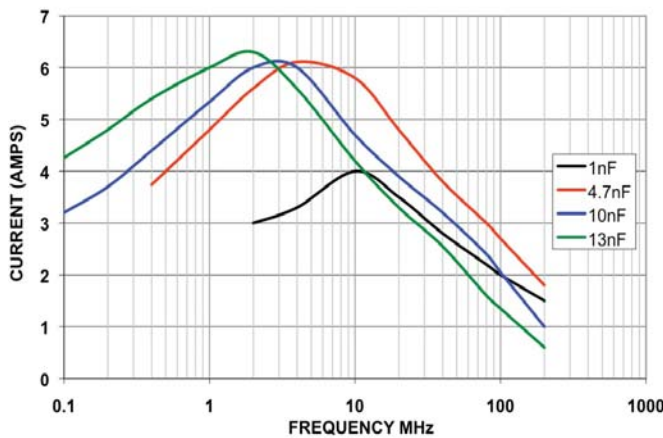

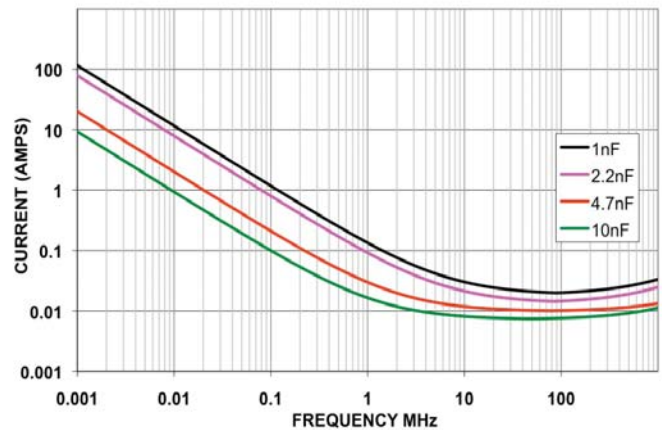

TYPICAL ESR 1KV 1812 NPO



## CASE SIZE

## RATED VOLTAGE

## AVAILABLE CAPACITANCE

|  | CASE SIZE |                        | RATED VOLTAGE |          | AVAILABLE CAPACITANCE |         |                |          |
|--|-----------|------------------------|---------------|----------|-----------------------|---------|----------------|----------|
|  | Inches    | (mm)                   | DC            | AC       | NPO Dielectric        |         | X7R Dielectric |          |
|  |           |                        |               |          | Minimum               | Maximum | Minimum        | Maximum  |
| <b>R18/1206</b><br> | L         | .125 ±.010 (3.17 ±.25) | 250 VDC       | 141 Vrms | -                     | -       | 1000 pF        | 0.068 µF |
|  | W         | .062 ±.010 (1.57 ±.25) | 500 VDC       | 283 Vrms | 10 pF                 | 1500 pF | 1000 pF        | 0.027 µF |
|  | T         | .067 Max. (1.70)       | 630 VDC       | 356 Vrms | 10 pF                 | 1200 pF | 1000 pF        | 0.010 µF |
|  | E/B       | .020 ±.010 (0.51 ±.25) | 1000 VDC      | 566 Vrms | 10 pF                 | 1000 pF | 100 pF         | 5600 pF  |
|  |           |                        |               |          |                       |         |                |          |
| <b>S41/1210</b><br> | L         | .125 ±.010 (3.18 ±.25) | 250 VDC       | 141 Vrms | -                     | -       | 1000 pF        | 0.120 µF |
|  | W         | .095 ±.010 (2.41 ±.25) | 500 VDC       | 283 Vrms | 10 pF                 | 3900 pF | 1000 pF        | 0.047 µF |
|  | T         | .080 Max. (2.03)       | 630 VDC       | 356 Vrms | 10 pF                 | 2700 pF | 1000 pF        | 0.027 µF |
|  | E/B       | .020 ±.010 (0.51 ±.25) | 1000 VDC      | 566 Vrms | 10 pF                 | 1800 pF | 100 pF         | 0.010 µF |
|  |           |                        |               |          |                       |         |                |          |
| <b>S43/1812</b><br> | L         | .180 ±.010 (4.57 ±.25) | 250 VDC       | 141 Vrms | -                     | -       | 0.010 µF       | 0.220 µF |
|  | W         | .125 ±.010 (3.17 ±.25) | 500 VDC       | 283 Vrms | 100 pF                | 8200 pF | 1000 pF        | 0.150 µF |
|  | T         | .110 Max. (2.80)       | 630 VDC       | 356 Vrms | 100 pF                | 6800 pF | 1000 pF        | 0.100 µF |
|  | E/B       | .025 ±.015 (0.64 ±.38) | 1000 VDC      | 566 Vrms | 10 pF                 | 5600 pF | 1000 pF        | 0.022 µF |
|  |           |                        |               |          |                       |         |                |          |

Please visit our website for additional product details and ordering information







Johanson's high temperature MLCC series exhibit stable performance across an extended operating temperature range of -55°C to +200°C. Both Class I and Class II parts are available with DC voltage ratings of 50, 100 and 200V satisfying a wide range of demanding applications.

## FEATURES

- Stable 200°C Operation
- Compact SMD Chip
- Polyterm® Termination Option
- Sn-Pb Termination Option

## APPLICATIONS

- Deep Hole Drilling Electronics
- High Temperature Modules
- Industrial Equipment
- Automotive • Avionics

## ELECTRICAL CHARACTERISTICS

|                        | NPO   | X7R               |
|------------------------|---|-------------------|
| OPERATING RANGE:       | -55 to +200°C   | -55 to +200°C     |
| TEMP. COEFFICIENT:     | 0±30ppm/°C  | +15% -45%         |
| DISSIPATION FACTOR:    | 0.001 (0.1%) max.   | 0.020 (2.0%) max. |
| AGING RATE:            | None  | <1.0% per decade  |
| INSULATION RESISTANCE: | 25°C IR >100GΩ or 1000 ΩF whichever<br>200°C IR >10 ΩF or 100 ΩF is less      |                   |
| WITHSTANDING VOLTAGE:  | 2.5 X WVDC for ratings ≤ 200 VDC<br>1.5 X WVDC for ratings 201-500 VDC        |                   |
| TEST CONDITIONS:       | C > 100 pF; 1kHz ±50Hz; 1.0±0.2 VRMS<br>C ≤ 100 pF; 1Mhz ±50kHz; 1.0±0.2 VRMS |                   |

## TEMPERATURE - VOLTAGE COEFFICIENT

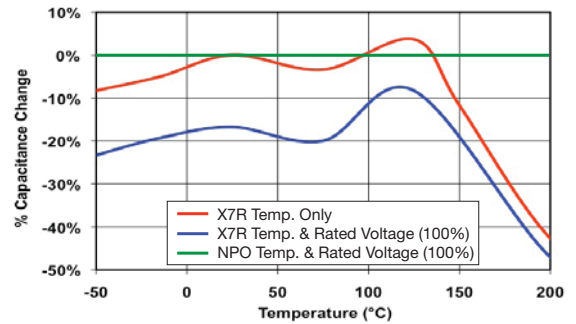

| CASE SIZE  | Inches  |            | (mm)        |         | Rated Voltage | NPO Dielectric |          | X7R Dielectric |          |
|------------|---------|------------|-------------|---------|---------------|----------------|----------|----------------|----------|
|            | Minimum | Maximum    | Minimum     | Maximum |               | Minimum        | Maximum  | Minimum        | Maximum  |
| ■ T14/0603 | L       | .063 ±.008 | (1.60 ±.20) |         | 50 VDC        | 10 pF          | 330 pF   | 100 pF         | 0.010 μF |
|            | W       | .032 ±.008 | (0.81 ±.20) |         | 100 VDC       | 10 pF          | 220 pF   | 100 pF         | 2200 pF  |
|            | T       | .035 Max.  | (0.89)      |         | 200 VDC       | 10 pF          | 120 pF   | 100 pF         | 5600 pF  |
| ■ T15/0805 | L       | .080 ±.010 | (2.03 ±.25) |         | 50 VDC        | 10 pF          | 1500 pF  | 1000 pF        | 0.033 μF |
|            | W       | .050 ±.010 | (1.27 ±.25) |         | 100 VDC       | 10 pF          | 1000 pF  | 1000 pF        | 0.010 μF |
|            | T       | .055 Max.  | (1.40)      |         | 200 VDC       | 10 pF          | 680 pF   | 1000 pF        | 2200 pF  |
| ■ T18/1206 | L       | .125 ±.010 | (3.17 ±.25) |         | 50 VDC        | 10 pF          | 3300 pF  | 1000 pF        | 0.100 μF |
|            | W       | .062 ±.010 | (1.57 ±.25) |         | 100 VDC       | 1.0 pF         | 2200 pF  | 1000 pF        | 0.022 μF |
|            | T       | .067 Max.  | (1.70)      |         | 200 VDC       | 1.0 pF         | 1500 pF  | 1000 pF        | 5600 pF  |
| ■ T41/1210 | L       | .125 ±.010 | (3.18 ±.25) |         | 50 VDC        | 10 pF          | 5600 pF  | 0.047 μF       | 0.220 μF |
|            | W       | .095 ±.010 | (2.41 ±.25) |         | 100 VDC       | 10 pF          | 4700 pF  | 0.047 μF       | 0.056 μF |
|            | T       | .090 Max.  | (2.03)      |         | 200 VDC       | 10 pF          | 3300 pF  | 0.047 μF       | 0.015 μF |
| ■ T43/1812 | L       | .175 ±.010 | (4.45 ±.25) |         | 50 VDC        | 1000 pF        | 0.012 μF | 0.047 μF       | 0.470 μF |
|            | W       | .125 ±.010 | (3.17 ±.25) |         | 100 VDC       | 1000 pF        | 0.010 μF | 0.047 μF       | 0.180 μF |
|            | T       | .110 Max.  | (2.80)      |         | 200 VDC       | 1000 pF        | 8200 pF  | 0.047 μF       | 0.047 μF |

Please visit our website for additional product details and ordering information



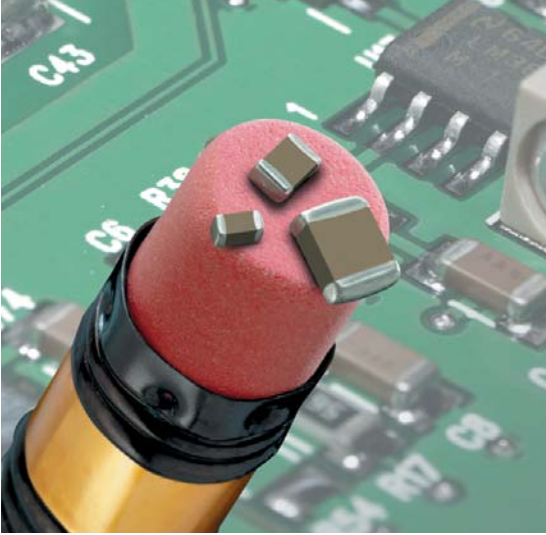

TANCERAM® chip capacitors can replace tantalum capacitors in many applications and offer several key advantages over traditional tantalums. Because Tanceram® capacitors exhibit extremely low ESR, equivalent circuit performance can often be achieved using considerably lower capacitance values. Low DC leakage reduces current drain, extending the battery life of portable products. Tancerams® high DC breakdown voltage ratings offer improved reliability and eliminate large voltage de-rating common when designing with tantalums.

## ADVANTAGES

- Low ESR
- Higher Surge Voltage
- Reduced CHIP Size
- Higher Insulation Resistance
- Low DC Leakage
- Non-polarized Devices
- Improved Reliability
- Higher Ripple Current

## APPLICATIONS

- Switching Power Supply Smoothing (Input/Output)
- DC/DC Converter Smoothing (Input/Output)
- Backlighting Inverters
- General Digital Circuits

Typical ESR Comparison

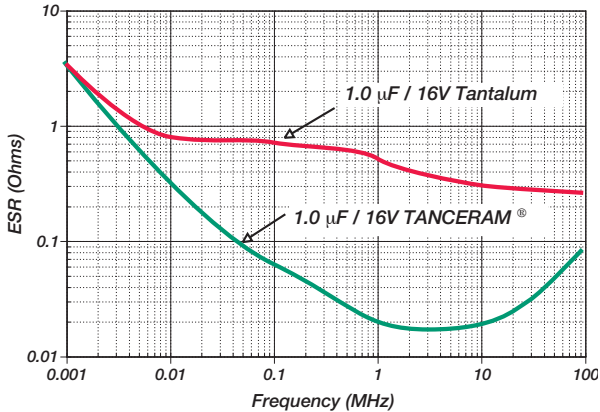

Typical Breakdown Voltage Comparison

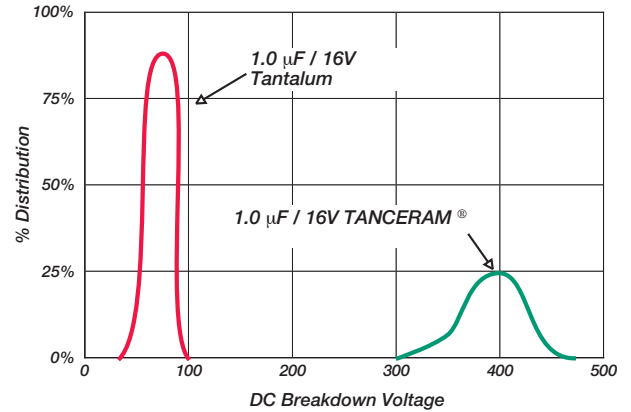

## HOW TO ORDER TANCERAM®

Part number written: 100R15X106MV4E

| 100  | R15         | X                  | 106   | M                    | V   | 4              | E  |
|--|-------------|--------------------|---|----------------------|---|----------------|--|
| <b>VOLTAGE</b>   | <b>SIZE</b> | <b>DIELECTRIC</b>  | <b>CAPACITANCE</b>  | <b>TOLERANCE</b>     | <b>TERMINATION</b>  | <b>MARKING</b> | <b>PACKING</b>   |
| 6R3 = 6.3 V<br>100 = 10 V<br>160 = 16 V<br>250 = 25 V<br>500 = 50 V<br>101 = 100 V | See Chart   | W = X7R<br>X = X5R | 1st two digits are significant; third digit denotes number of zeros.<br>105 = 1.00 µF<br>476 = 4.70 µF<br>107 = 10.0 µF | K = ±10%<br>M = ±20% | V = Nickel Barrier with 100% Tin Plating (Matte)<br><br>T = SnPb*<br>(*available on select parts) | 4 = Unmarked   | Code Type Reel<br>E Plastic 7"<br>T Paper 7"<br>Tape specifications conform to EIA RS481 |



## CASE SIZE

## CAPACITANCE SELECTION

| EIA / JDI   | Inches | (mm)            | VDC             | 1.0 μF | 2.2 μF | 3.3 μF | 4.7 μF | 10 μF | 22 μF | 47 μF | 100 μF |
|-------------|--------|-----------------|-----------------|--------|--------|--------|--------|-------|-------|-------|--------|
| 0402<br>R07 | L      | .040 ±.004      | (1.02 ±.10)     |        |        |        |        |       |       |       |        |
|             | W      | .020 ±.004      | (0.51 ±.10)     |        |        |        |        |       |       |       |        |
|             | T      | .025 Max.       | (0.64)          |        |        |        |        |       |       |       |        |
|             | EB     | .008 ±.004      | (0.20±.10)      |        |        |        |        |       |       |       |        |
| 0603<br>R14 | L      | .063 ±.008      | (1.60 ±.20)     |        |        |        |        |       |       |       |        |
|             | W      | .032 ±.008      | (0.81 ±.20)     |        |        |        |        |       |       |       |        |
|             | T      | .035 Max.       | (0.89)          |        |        |        |        |       |       |       |        |
|             | EB     | .010±.005       | (.25±.13)       |        |        |        |        |       |       |       |        |
| 0805<br>R15 | L      | .080 ±.010      | (2.03 ±.25)     |        |        |        |        |       |       |       |        |
|             | W      | .050 ±.010      | (1.27 ±.25)     |        |        |        |        |       |       |       |        |
|             | T      | .060 Max.       | (1.52)          |        |        |        |        |       |       |       |        |
|             | EB     | .020±.010       | (0.51±.25)      |        |        |        |        |       |       |       |        |
| 1206<br>R18 | L      | .125 ±.010      | (3.17 ±.25)     |        |        |        |        |       |       |       |        |
|             | W      | .062 ±.010      | (1.57 ±.25)     |        |        |        |        |       |       |       |        |
|             | T      | .070 Max.       | (1.78)          |        |        |        |        |       |       |       |        |
|             | EB     | .020 +.015-.010 | (0.51+ .38-.25) |        |        |        |        |       |       |       |        |
|             |        |                 |                 | 100    |        |        |        |       |       |       |        |
|             |        |                 |                 | 50     |        |        |        |       |       |       |        |
| 1210<br>S41 | L      | .125 ±.010      | (3.18 ±.25)     |        |        |        |        |       |       |       |        |
|             | W      | .095 ±.010      | (2.41 ±.25)     |        |        |        |        |       |       |       |        |
|             | T      | .110 Max.       | (2.8)           |        |        |        |        |       |       |       |        |
|             | EB     | .020 +.015-.010 | (0.51+ .38-.25) |        |        |        |        |       |       |       |        |
|             |        |                 |                 | 100    |        |        |        |       |       |       |        |
|             |        |                 |                 | 50     |        |        |        |       |       |       |        |
| 1812<br>S43 | L      | .175 ±.010      | (4.45 ±.25)     |        |        |        |        |       |       |       |        |
|             | W      | .125 ±.010      | (3.17 ±.25)     |        |        |        |        |       |       |       |        |
|             | T      | .140 Max.       | (3.55)          |        |        |        |        |       |       |       |        |
|             | EB     | .035 ±.020      | (0.89 ±0.51)    |        |        |        |        |       |       |       |        |
|             |        |                 |                 | 100    |        |        |        |       |       |       |        |
|             |        |                 |                 | 50     |        |        |        |       |       |       |        |

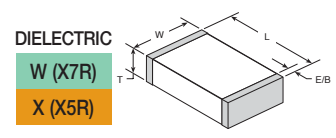

|   |   |   |   |   |   |   |   |   |   |   |   |   |   |   |   |
|---|---|---|---|---|---|---|---|---|---|---|---|---|---|---|---|
| W | X | W | X | W | X | W | X | W | X | W | X | W | X | W | X |
|---|---|---|---|---|---|---|---|---|---|---|---|---|---|---|---|

## ELECTRICAL CHARACTERISTICS

| Dielectric:                               | X7R  | X5R   |
|---|--|---|
| Temperature Coefficient:                  | ±15% (-55 to +125°C)   | ±15% (-55 to +85°C)                             |
| Dissipation Factor:                       | For ≥ 50 VDC: 5% max.<br>For ≤ 25 VDC: 10% max.  | For ≥ 50 VDC: 5% max.<br>For ≤ 25 VDC: 10% max. |
| Insulation Resistance (Min. @ 25°C, Wvdc) | 100 ΩF or 10 GΩ, whichever is less   |   |
| Dielectric Strength:                      | 2.5 X WVDC, 25°C, 50mA max.  |   |
| Test Conditions:                          | Capacitance values ≤ 22 μF: 1.0kHz±50Hz @ 1.0±0.2 Vrms<br>Capacitance values > 22 μF: 120Hz±10Hz @ 0.5V±0.1 Vrms |   |
| Other:                                    | See page 35 for additional dielectric specifications.  |   |





# STACKED SMPS CERAMIC CAPACITORS



Switch-Mode ceramic capacitors feature large capacitance values and exhibit low ESR (equivalent series resistance) and low ESL (equivalent series inductance) making them well suited for high power and high frequency applications where tantalum or aluminum electrolytic capacitors may not be suitable. The P-Series feature mechanical and pin-out configurations per DSCC 87106 and 88011 drawings while the E-Series feature mechanical and pin-out configurations more common in European design applications.

## KEY FEATURES

- P-Series Approved to DSCC Drawings 87106 & 88011 MIL-PRF-49470
- **New T-Series 200°C** for downhole tools and aircraft engine control applications.
- E-Series Common European Lead Styles available to MIL-PRF-49470 requirements.
- NPO & X7R Dielectrics, 50 to 500 VDC Ratings
- Low ESR / Low ESL, Ideal for SMPS Filtering Applications
- Custom Sizes, Voltages, and Values Available

## CASE SIZE

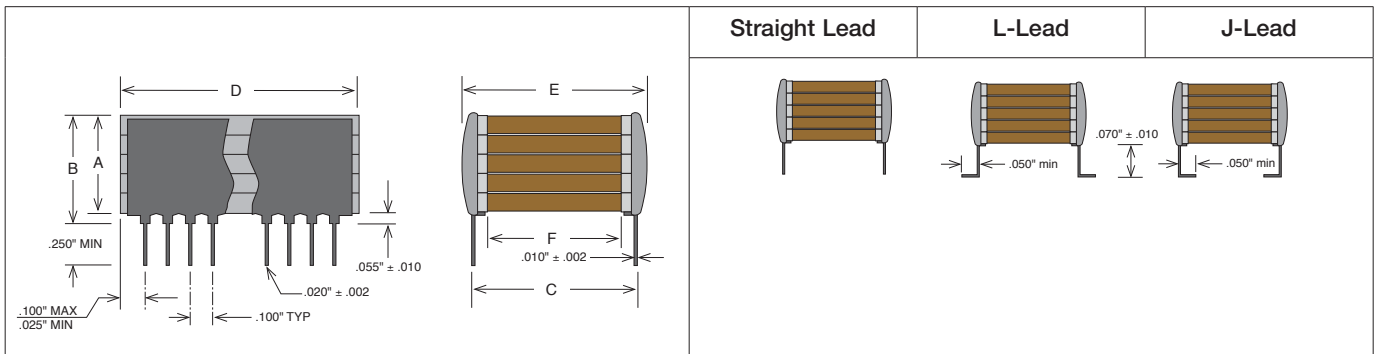

## HOW TO ORDER STACKED SMPS

Part number written: 201P03W275KJ4H

| 201   | P03       | W                            | 275   | K   | J  | 4                             | H   |
|---|-----------|------------------------------|---|---|--|-------------------------------|---|
| VOLTAGE   | SIZE      | DIELECTRIC                   | CAPACITANCE   | TOLERANCE   | TERMINATION  | MARKING                       | PACKING   |
| 500 = 50 V<br>101 = 100 V<br>201 = 200 V<br>501 = 500 V | See Chart | N = NPO<br>B = BX<br>W = X7R | 1st two digits are significant; third digit denotes number of zeros.<br>101 = 100 pF<br>102 = 1000 pF<br>103 = 0.01 μF<br>105 = 1.00 μF | J = ±5%<br>K = ±10%<br>L = ±15%<br>M = ±20%<br>N = ±30%<br>Z = +80% -20%<br>P = +100% -0% | J = "J" Leads (formed in)<br>L = "L" Leads (formed out)<br>M = "L" Leads with reduced height of .045" +/- .010"<br>N = Straight Lead | 4 = Standard<br>3 = Specified | T = Tape and Reel<br>H = High Reliability testing per customer requirements<br>S = Special Part |



# STACKED SMPS CERAMIC CAPACITORS

## P-SERIES DSCC STYLE X7R CAPACITANCE / VOLTAGE SELECTION

| CASE SIZE | NO. CHIPS | LEADS /SIDE | Mechanical Size Range (In.) |           |          | X7R Max Capacitance (µF) |      |      |      |
|-----------|-----------|-------------|-----------------------------|-----------|----------|--------------------------|------|------|------|
|           |           |             | Length (D)                  | Width (E) | Tmax (B) | 50V                      | 100V | 200V | 500V |
| P05       | 1         | 3           | 0.275                       | 0.300     | .185     | 3.0                      | 2.2  | 1.0  | 0.50 |
| P55       | 5         |             |                             |           | .715     | 15                       | 11   | 5.0  | 2.5  |
| P04       | 1         | 4           | 0.425                       | 0.440     | .185     | 9.0                      | 6.5  | 3.0  | 1.5  |
| P54       | 5         |             |                             |           | .715     | 45                       | 32   | 15   | 7.5  |
| P03       | 1         | 10          | 1.075                       | 0.500     | .185     | 28                       | 20   | 9.5  | 4.7  |
| P53       | 5         |             |                             |           | .715     | 140                      | 100  | 47   | 23   |
| P01       | 1         | 20          | 2.075                       | 0.500     | .185     | 50                       | 40   | 19   | 9.4  |
| P51       | 5         |             |                             |           | .715     | 250                      | 200  | 95   | 46   |
| P02       | 1         | 15          | 1.535                       | 0.870     | .185     | 75                       | 55   | 25   | 14   |
| P52       | 5         |             |                             |           | .715     | 370                      | 270  | 125  | 70   |
| P06       | 1         | 20          | 2.075                       | 1.350     | .185     | 160                      | 110  | 50   | 25   |
| P56       | 5         |             |                             |           | .715     | 800                      | 550  | 250  | 125  |

Partial product line listing, please refer to our website for complete offering including NPO & BX capacitance ranges. .

## NEW 200°C T-SERIES CAPACITANCE / VOLTAGE SELECTION

| CASE SIZE | NO. CHIPS | LEADS /SIDE | Mechanical Size Range (In.) |           |          | Max Capacitance (µF) |      |      |
|-----------|-----------|-------------|-----------------------------|-----------|----------|----------------------|------|------|
|           |           |             | Length (D)                  | Width (E) | Tmax (B) | 50V                  | 100V | 200V |
| T05       | 1         | 3           | 0.275                       | 0.300     | .185     | 1.20                 | 0.68 | 0.33 |
| T55       | 5         |             |                             |           | .715     | 5.60                 | 3.30 | 1.50 |
| T04       | 1         | 4           | 0.425                       | 0.440     | .185     | 2.70                 | 1.50 | 0.82 |
| T54       | 5         |             |                             |           | .715     | 15.0                 | 8.20 | 3.90 |
| T03       | 1         | 10          | 1.075                       | 0.500     | .185     | 10.0                 | 5.60 | 2.70 |
| T53       | 5         |             |                             |           | .715     | 47.0                 | 27.0 | 12.0 |

Partial product line listing, please refer to our website for complete offering including NPO capacitance ranges.

## E-SERIES EUROPEAN STYLE X7R CAPACITANCE / VOLTAGE SELECTION

| CASE SIZE | NO. CHIPS | LEADS /SIDE | Mechanical Size Range (mm) |           |          | X7R Max Capacitance (µF) |      |      |      |
|-----------|-----------|-------------|----------------------------|-----------|----------|--------------------------|------|------|------|
|           |           |             | Length (D)                 | Width (E) | Tmax (B) | 50V                      | 100V | 200V | 500V |
| E24       | 1         | 3           | 8.7                        | 9.2       | 3.8      | 5.0                      | 4.0  | 2.5  | 1.0  |
| E54       | 4         |             |                            |           | 14.8     | 20                       | 16   | 10   | 4.0  |
| E26       | 1         | 5           | 13.6                       | 14.9      | 3.       | 16                       | 12   | 7.5  | 3.3  |
| E56       | 4         |             |                            |           | 14.8     | 64                       | 48   | 30   | 13   |
| E21       | 1         | 6           | 16.6                       | 21.6      | 3.8      | 30                       | 22   | 14   | 6.0  |
| E51       | 4         |             |                            |           | 14.8     | 120                      | 88   | 56   | 24   |
| E28       | 1         | 14          | 38.2                       | 12.0      | 3.8      | 35                       | 25   | 16   | 7.0  |
| E58       | 4         |             |                            |           | 14.8     | 140                      | 100  | 64   | 28   |
| E29       | 1         | 14          | 40.6                       | 24.0      | 3.8      | 75                       | 50   | 35   | 16   |
| E59       | 4         |             |                            |           | 14.8     | 300                      | 200  | 140  | 64   |

Partial product line listing, please refer to our website for complete offering including NPO & BX capacitance ranges.



# MINI-SWITCH MODE® CAPACITORS

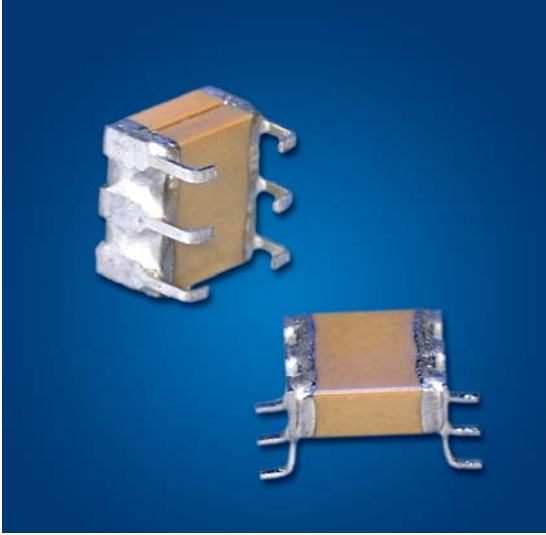

JDI's Mini-Switch Mode® ceramic capacitors combine the advantages of high capacitance found in tantalum capacitors with very low ESR performance of ceramic capacitors. The “J” and “L” lead configurations replace 1825 and 2225 SMT chips to provide stress relief and prevent cracking due to thermal cycling or mechanical board flexing. Another plus of the J-lead style is that this configuration allows use of the same solder lands as the SMT chips. See the Switch-Mode section for larger values. See also the Technical Notes on soldering and handling and suggested solder lands.

## FEATURES

- High Capacitance, Small Size
- Low ESR/ESL
- Leadframe reduces thermal & mechanical stress due to board flexure and TCE mismatch

## APPLICATIONS

- DC-DC Converters
- Power Supply Input & Output Filters

## CAPACITANCE SELECTION

| SIZE CODE | EIA CHIP SIZE | NPO Max Capacitance (uF) |       |       |       |       | X7R Max Capacitance (uF) |     |      |      |      |
|-----------|---------------|--------------------------|-------|-------|-------|-------|--------------------------|-----|------|------|------|
|           |               | 25V                      | 50V   | 100V  | 200V  | 500V  | 25V                      | 50V | 100V | 200V | 500V |
| P09       | 1825          | 0.056                    | 0.047 | 0.039 | 0.027 | 0.018 | 1.5                      | 1.2 | 0.75 | 0.56 | 0.27 |
| P29       | 1825          | 0.11                     | 0.094 | 0.078 | 0.054 | 0.036 | 3.0                      | 2.4 | 1.5  | 1.1  | 0.54 |
| P39       | 1825          | 0.16                     | 0.14  | 0.11  | 0.081 | 0.054 | 4.5                      | 3.6 | 2.2  | 1.6  | 0.81 |
| P49       | 1825          | 0.22                     | 0.18  | 0.15  | 0.10  | 0.07  | 6.0                      | 4.8 | 3.0  | 2.2  | 1.0  |
| P08       | 2225          | 0.068                    | 0.056 | 0.047 | 0.033 | 0.027 | 2.7                      | 2.2 | 1.5  | 1.2  | 0.39 |
| P28       | 2225          | 0.13                     | 0.11  | 0.094 | 0.066 | 0.054 | 5.4                      | 4.4 | 3.0  | 2.4  | 0.78 |
| P38       | 2225          | 0.20                     | 0.16  | 0.14  | 0.10  | 0.081 | 8.1                      | 6.6 | 4.5  | 3.6  | 1.1  |
| P48       | 2225          | 0.27                     | 0.22  | 0.18  | 0.13  | 0.10  | 10                       | 8.8 | 6.0  | 4.8  | 1.5  |



# MINI-SWITCH MODE® CAPACITORS

## CASE SIZE

| Dimensions Applicable to all sizes:      |      |      |       |      |      |      |      |      |       |      |       |      |       |      |       |      |       |      |
|--|------|------|-------|------|------|------|------|------|-------|------|-------|------|-------|------|-------|------|-------|------|
|  | In.  | mm   |       |      |      |      |      |      |       |      |       |      |       |      |       |      |       |      |
| $h \pm .010$                             | .070 | 1.78 |       |      |      |      |      |      |       |      |       |      |       |      |       |      |       |      |
| c Typ.                                   | .100 | 2.54 |       |      |      |      |      |      |       |      |       |      |       |      |       |      |       |      |
| $p \pm .015$                             | .065 | 1.65 |       |      |      |      |      |      |       |      |       |      |       |      |       |      |       |      |
| Dimensions Applicable to specific sizes: |      |      | P08   |      | P09  |      | P28  |      | P29   |      | P38   |      | P39   |      | P48   |      | P49   |      |
|  | In.  | mm   | In.   | mm   | In.  | mm   | In.  | mm   | In.   | mm   | In.   | mm   | In.   | mm   | In.   | mm   | In.   | mm   |
| L max                                    | .280 | 7.11 | 0.24  | 6.1  | 0.28 | 7.11 | 0.24 | 6.1  | 0.28  | 7.11 | 0.24  | 6.1  | 0.28  | 7.11 | 0.24  | 6.1  | 0.28  | 7.11 |
| W max                                    | .270 | 6.86 | 0.27  | 6.86 | 0.27 | 6.86 | 0.27 | 6.86 | 0.27  | 6.86 | 0.27  | 6.86 | 0.27  | 6.86 | 0.27  | 6.86 | 0.27  | 6.86 |
| T max                                    | .095 | 2.41 | 0.095 | 2.41 | 0.19 | 4.83 | 0.19 | 4.83 | 0.285 | 7.24 | 0.285 | 7.24 | 0.285 | 7.24 | 0.285 | 7.24 | 0.285 | 7.24 |

Note: J-Lead and L-Lead options are available on all sizes above

## ELECTRICAL CHARACTERISTICS

| Dielectric:                               | NPO   | X7R                                |
|---|---|------------------------------------|
| Temperature Coefficient:                  | 0 ±30ppm/°C (-55 to +125°C)   | ±15% (-55 to +125°C)               |
| Dissipation Factor:                       | 0.1% max.   | 2.5% max.                          |
| Aging                                     | None  | -2.5% per decade hour              |
| Insulation Resistance (Min. @ 25°C, WVDC) | 1000 ΩF or 100 GΩ, whichever is less  | 500 ΩF or 50 GΩ, whichever is less |
| Dielectric Strength:                      | For 500V Ratings: 750VDC, 25°C, 50mA max<br>For 200V Ratings: 2xWVDC, 25°C, 50mA max<br>For 25-100V Ratings: 2.5xWVDC, 25°C, 50mA max |                                    |
| Test Conditions:                          | 1kHz ±50Hz; 1.0±0.2 VRMS  |                                    |
| Other:                                    | See page 35 for additional dielectric specifications.   |                                    |

## HOW TO ORDER - MINI-SWITCH MODE®

Part number written: 500P28W395KJ4U

| 500   | P28         | W                  | 395  | K  | J   | 4              | U  |
|---|-------------|--------------------|--|--|---|----------------|--|
| <b>VOLTAGE</b>  | <b>SIZE</b> | <b>DIELECTRIC</b>  | <b>CAPACITANCE</b>   | <b>TOLERANCE</b>                                 | <b>TERMINATION</b>                                      | <b>MARKING</b> | <b>PACKING</b>   |
| 250 = 25 V<br>500 = 50 V<br>101 = 100 V<br>201 = 200 V<br>501 = 500 V | See Chart   | N = NPO<br>W = X7R | 1st two digits are significant; third digit denotes number of zeros.<br>103 = 0.01 μF<br>105 = 1.0 μF<br>106 = 10 μF | J = ±5%<br>K = ±10%<br>M = ±20%<br>Z = +80% -20% | J = "J" Leads (formed in)<br>L = "L" Leads (formed out) | 4 = Unmarked   | U = Tape and Reel 16mm, 13" Reel<br>NONE = Bulk pack<br>H = High Reliability testing per customer requirements<br>S = Special Part |





Johanson Dielectrics Maxi-cap™ Series of ultra high capacitance stacked ceramic capacitors exhibit very low ESR/ESL for high current handling capability in small sizes. The J lead configuration provides good mechanical and thermal stress performance and is similar to the leadframe used in high-rel applications. In addition the J-lead configuration allows direct substitution of SMT chip footprints. The standard range is offered in 1 and 2 chip horizontal stacks giving potential board space savings.

## FEATURES

- High Capacitance, Small Size
- Low ESR/ESL
- Leadframe reduces thermal & mechanical stress due to board flexure and TCE mismatch
- Green / ROHS Compliant

## APPLICATIONS

- DC-DC Converters
- Power Supply Input & Output Filters

## AVAILABLE CAPACITANCE (X7R DIELECTRIC)

| RATED DC VOLTAGE | P0A         | P07         | P2A         | P27        |
|------------------|-------------|-------------|-------------|------------|
| 50V              | 4.7 $\mu$ F | 10 $\mu$ F  | 10 $\mu$ F  | 22 $\mu$ F |
| 100V             | 2.2 $\mu$ F | 4.7 $\mu$ F | 4.7 $\mu$ F | 10 $\mu$ F |

## CASE SIZE

| Dimensions Applicable to specific sizes: |  |  | P0A   |     | P07   |     | P2A   |     | P27   |     |      |      |
|--|--|--|-------|-----|-------|-----|-------|-----|-------|-----|------|------|
|  |  |  | In.   | mm  | In.   | mm  | In.   | mm  | In.   | mm  |      |      |
| L Max                                    |  |  | 0.217 | 5.5 | 0.256 | 6.5 | 0.217 | 5.5 | 0.256 | 6.5 |      |      |
| W Max                                    |  |  | 0.157 | 4.0 | 0.217 | 5.5 | 0.157 | 4.0 | 0.217 | 5.5 |      |      |
| H Max                                    |  |  | 0.118 | 3.0 | 0.118 | 3.0 | 0.236 | 6.0 | 0.236 | 6.0 |      |      |
| Dimensions Applicable to all sizes:      |  |  |       |     |       |     |       |     |       |     |      |      |
|  |  |  |       |     |       |     |       |     |       |     | In.  | mm   |
| h1 Max                                   |  |  |       |     |       |     |       |     |       |     | .059 | 1.50 |
| c Typ.                                   |  |  |       |     |       |     |       |     |       |     | .100 | 2.54 |
| p1 Typ.                                  |  |  |       |     |       |     |       |     |       |     | .020 | 0.50 |
| p2 ± 0.02                                |  |  |       |     |       |     |       |     |       |     | .065 | 1.65 |



# MAXI-CAP™ STACKED CAPACITORS



TYPICAL APPLICATION: DC-DC Converter Input & Output Filtering

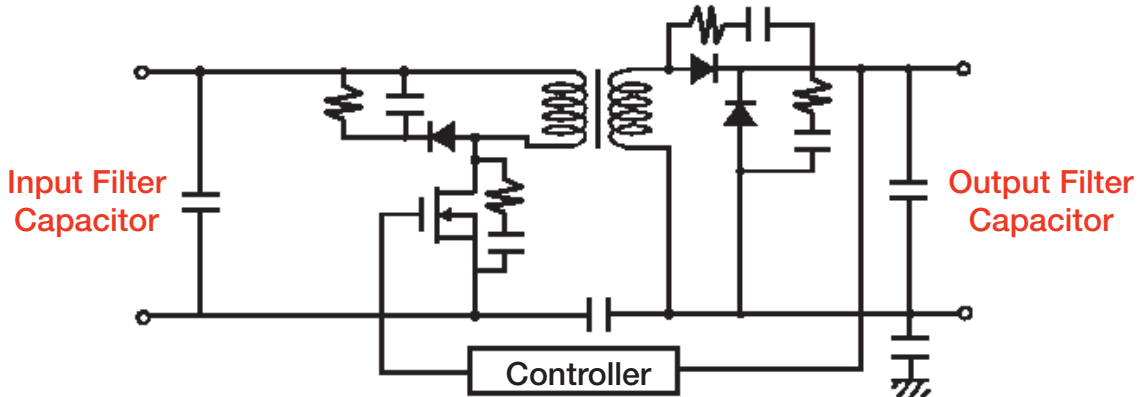

## ELECTRICAL CHARACTERISTICS

|                          |   |
|--------------------------|---|
| OPERATING RANGE:         | -55 to +125°C                                   |
| TEMPERATURE COEFFICIENT: | X7R, ±15%                                       |
| DISSIPATION FACTOR:      | 0.020 (2.0%) max.                               |
| AGING RATE:              | <2.5% per decade                                |
| INSULATION RESISTANCE:   | 25°C IR >100GΩ or 1000 ΩF<br>whichever is less  |
| WITHSTANDING VOLTAGE:    | 2.5 X WVDC for 50 VDC<br>2.0 X WVDC for 100 VDC |
| TEST CONDITIONS:         | 1kHz ±50Hz; 1.0±0.2 VRMS, 25°C                  |

MAXICAP TEMPERATURE COEFFICIENT

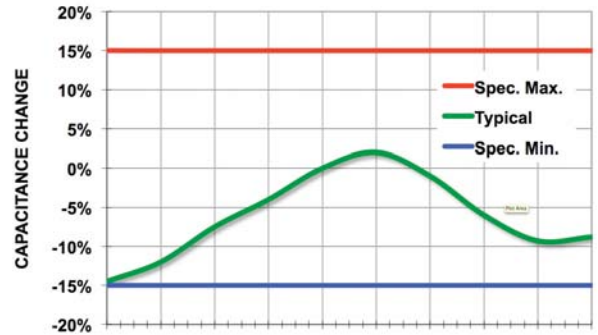

## HOW TO ORDER - MAXI-CAP™

Part number written: 500P07W106MJ4U+RC

|                           |             |                   |   |                  |                           |                |  |                      |
|---------------------------|-------------|-------------------|---|------------------|---------------------------|----------------|--|----------------------|
| <b>500</b>                | <b>P07</b>  | <b>W</b>          | <b>106</b>  | <b>M</b>         | <b>J</b>                  | <b>4</b>       | <b>U</b>                                 | <b>+RC</b>           |
| <b>VOLTAGE</b>            | <b>SIZE</b> | <b>DIELECTRIC</b> | <b>CAPACITANCE</b>  | <b>TOLERANCE</b> | <b>TERMINATION</b>        | <b>MARKING</b> | <b>PACKING</b>                           | <b>ROHS CODE</b>     |
| 500 = 50 V<br>101 = 100 V | See Chart   | W = X7R           | 1st two digits are significant; third digit denotes number of zeros.<br>225 = 2.2 μF<br>106 = 10 uF | M = ±20%         | J = "J" Leads (formed in) | 4 = Unmarked   | U = Embossed Tape 13" Reel per EIA RS481 | +RC = RoHS Compliant |



# X2Y<sup>®</sup> SWITCH-MODE CERAMIC CAPACITORS

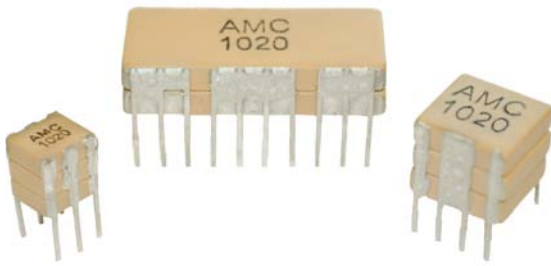

JDI's new X2Y<sup>®</sup> Technology Switch-Mode ceramic capacitors exhibit significantly lower ESL making them ideally suited for applications where high frequency filtering performance is critical. Lower ESL performance translates to significant size and weight reduction because lower capacitance values perform as well or better

## KEY FEATURES

- Low ESR / Low ESL, Ideal for SMPS Filtering Applications
- Same Package Size as DSCC Drawings 87106 & 88011 MIL-PRF-49470
- NPO & X7R Dielectrics, 50 to 500 VDC Ratings
- Custom Sizes, Voltages, and Values Available

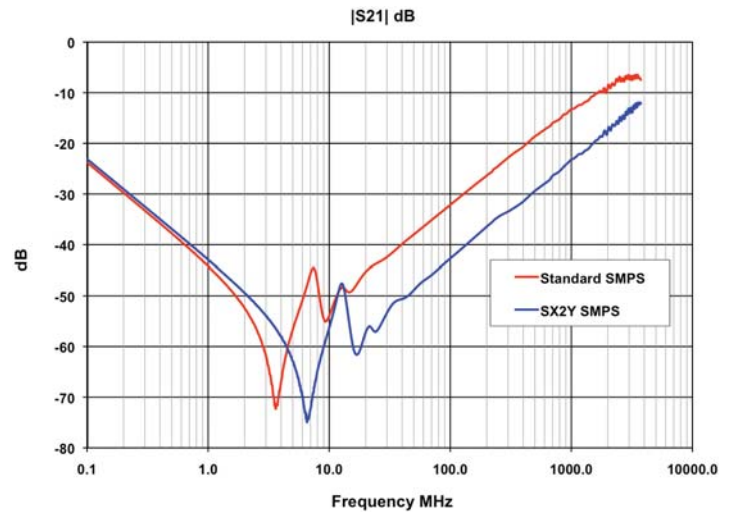
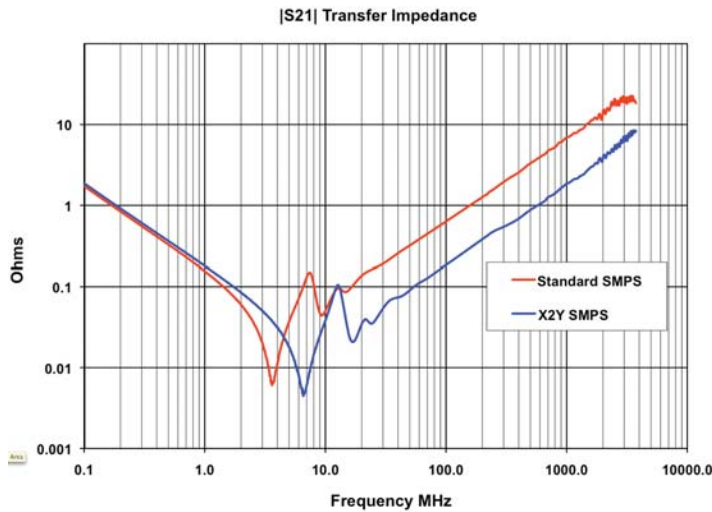

## CAPACITANCE / VOLTAGE SELECTION

| Rated DC Voltage | Maximum X7R Capacitance Per Case Size (µF) |     |     |     |     |     |     |     |     |     |     |     |     |     |     |
|------------------|--|-----|-----|-----|-----|-----|-----|-----|-----|-----|-----|-----|-----|-----|-----|
|                  | Y05  | Y25 | Y35 | Y45 | Y55 | Y04 | Y24 | Y34 | Y44 | Y54 | Y03 | Y23 | Y33 | Y43 | Y53 |
| 50V              | 2.7  | 5.0 | 8.0 | 11  | 14  | 8.3 | 17  | 25  | 33  | 41  | 29  | 58  | 87  | 116 | 145 |
| 100V             | 2.0  | 4.0 | 6.0 | 8.0 | 10  | 6.0 | 12  | 17  | 24  | 29  | 21  | 41  | 62  | 83  | 104 |
| 200V             | 0.9  | 1.8 | 2.7 | 4.0 | 5.0 | 2.8 | 5.5 | 8.3 | 11  | 14  | 9.8 | 20  | 29  | 39  | 49  |
| 500V             | 0.5  | 0.9 | 1.4 | 1.8 | 2.3 | 1.4 | 2.8 | 4.1 | 5.5 | 6.9 | 4.9 | 9.7 | 14  | 19  | 24  |



# X2Y<sup>®</sup> SWITCH-MODE CERAMIC CAPACITORS

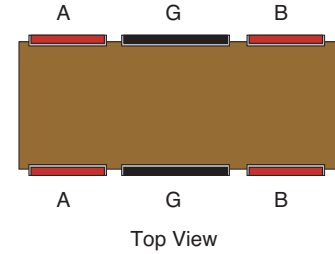
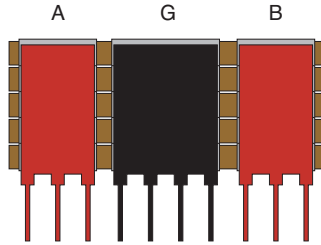
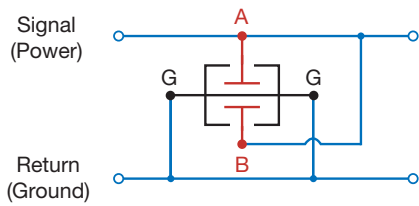

Contact the factory for additional connection options for dual signal line EMI filtering applications.

## CASE SIZE

|             | CASE SIZES  |      |      |      |      |  |      |      |      |      |   |      |      |      |      |
|-------------|---|------|------|------|------|--|------|------|------|------|---|------|------|------|------|
|             | Y05   | Y25  | Y35  | Y45  | Y55  | Y04  | Y24  | Y34  | Y44  | Y54  | Y03   | Y23  | Y33  | Y43  | Y53  |
| <b>A</b>    | .120  | .240 | .360 | .480 | .650 | .120   | .240 | .360 | .480 | .650 | .120  | .240 | .360 | .480 | .650 |
| <b>B</b>    | .185  | .305 | .425 | .545 | .715 | .185   | .305 | .425 | .545 | .715 | .185  | .305 | .425 | .545 | .715 |
| <b>C</b>    | .250  |      |      |      |      | .400   |      |      |      |      | .450  |      |      |      |      |
| <b>D-</b>   | .224  |      |      |      |      | .350   |      |      |      |      | .950  |      |      |      |      |
| <b>D+</b>   | .275  |      |      |      |      | .425   |      |      |      |      | 1.075   |      |      |      |      |
| <b>E</b>    | .300  |      |      |      |      | .440   |      |      |      |      | .500  |      |      |      |      |
| <b>Pins</b> | 3 per side, configuration:<br>a = 1, b = 1, g = 1 |      |      |      |      | 5 per side, configuration<br>a = 1, b = 1, g = 3 |      |      |      |      | 10 per side, configuration<br>a = 3, b = 3, g = 4 |      |      |      |      |

All dimensions are in inches. Tolerances are maximum except: C = ±.025" D- = minimum, D+ = maximum, F = minimum

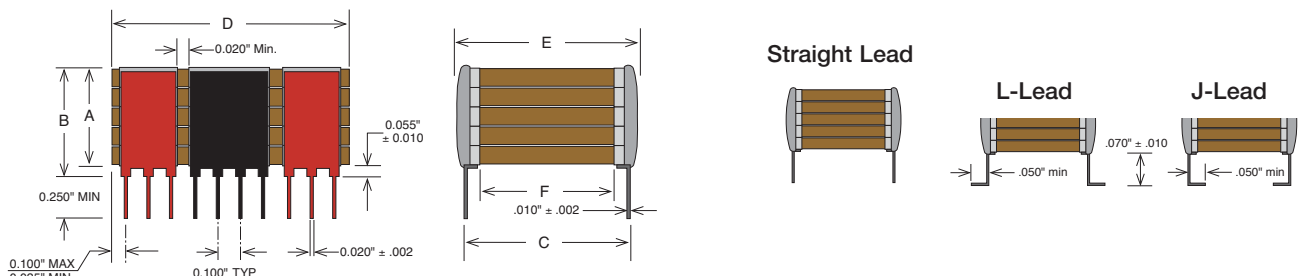

## HOW TO ORDER - X2Y<sup>®</sup> SMPS

Part number written: 201Y03W475KJ4H

| 201   | Y03       | W          | 475   | M         | J  | 4                             | H   |
|---|-----------|------------|---|-----------|--|-------------------------------|---|
| VOLTAGE   | SIZE      | DIELECTRIC | CAPACITANCE   | TOLERANCE | TERMINATION  | MARKING                       | PACKING   |
| 500 = 50 V<br>101 = 100 V<br>201 = 200 V<br>501 = 500 V | See Chart | W = X7R    | 1st two digits are significant; third digit denotes number of zeros.<br><br>104 = 0.10 µF<br>105 = 1.00 µF<br>475 = 4.70 µF | M = ±20%  | J = "J" Leads (formed in)<br>L = "L" Leads (formed out)<br>N = Straight Lead | 4 = Standard<br>3 = Specified | T = Tape and Reel<br>H = High Reliability testing per customer requirements<br>S = Special Part |



# SWITCH-MODE RADIAL LEADED CAPACITORS

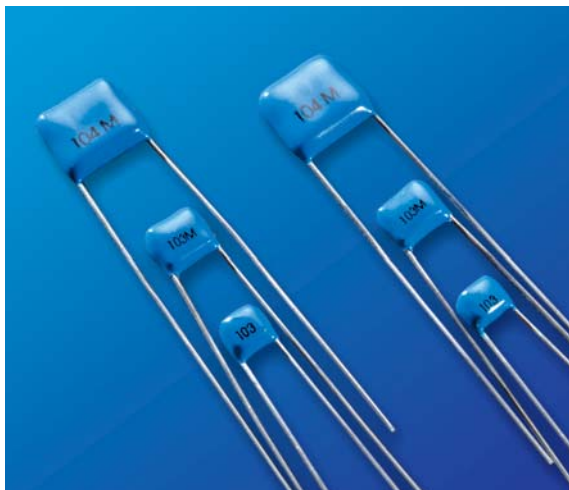





## KEY FEATURES





- Rated Working Voltages from 25 to 500 VDC
- Rugged Epoxy Coating Offers Increased Protection
- Hi-Rel Screened Versions Available
- Custom Sizes, Voltages, and Values Available

## ADVANTAGES

- Power Supplies
- Voltage Multipliers
- Data Isolation
- Surge Protection
- Industrial Control Circuits
- Custom Applications

| CASE SIZE   | In. |           | RATED VOLTAGE | NPO CAPACITANCE (MAX.) |              | X7R CAPACITANCE (MAX.) |              |     |
|---|-----|-----------|---------------|------------------------|--------------|------------------------|--------------|-----|
|   |     | (mm)      |               |                        |              |                        |              |     |
| <br><b>H03</b>  | W   | .300 max. | (7.62 max.)   | 25 VDC                 | .070 $\mu$ F | 703                    | 2.00 $\mu$ F | 205 |
|   | H   | .300 max. | (7.62 max.)   | 50 VDC                 | .060 $\mu$ F | 603                    | 1.60 $\mu$ F | 165 |
|   | T   | .200 max. | (5.08 max.)   | 100 VDC                | .050 $\mu$ F | 503                    | 1.10 $\mu$ F | 115 |
|   | S   | .200 nom. | (5.08 nom.)   | 200 VDC                | .040 $\mu$ F | 403                    | .730 $\mu$ F | 734 |
|   | Ld  | .020 nom. | (.510 nom.)   | 500 VDC                | .020 $\mu$ F | 203                    | .250 $\mu$ F | 254 |
| <br><b>H04</b> | W   | .400 max. | (10.2 max.)   | 25 VDC                 | .120 $\mu$ F | 124                    | 5.10 $\mu$ F | 515 |
|   | H   | .400 max. | (10.2 max.)   | 50 VDC                 | .100 $\mu$ F | 104                    | 4.10 $\mu$ F | 415 |
|   | T   | .200 max. | (5.08 max.)   | 100 VDC                | .082 $\mu$ F | 823                    | 2.70 $\mu$ F | 275 |
|   | S   | .200 nom. | (5.08 nom.)   | 200 VDC                | .050 $\mu$ F | 503                    | 1.80 $\mu$ F | 185 |
|   | Ld  | .020 nom. | (.510 nom.)   | 500 VDC                | .030 $\mu$ F | 303                    | .670 $\mu$ F | 674 |
| <br><b>H05</b> | W   | .500 max. | (12.7 max.)   | 25 VDC                 | .240 $\mu$ F | 244                    | 8.70 $\mu$ F | 875 |
|   | H   | .500 max. | (12.7 max.)   | 50 VDC                 | .200 $\mu$ F | 204                    | 7.20 $\mu$ F | 725 |
|   | T   | .200 max. | (5.08 max.)   | 100 VDC                | .180 $\mu$ F | 184                    | 4.80 $\mu$ F | 485 |
|   | S   | .400 nom. | (10.2 nom.)   | 200 VDC                | .110 $\mu$ F | 114                    | 3.30 $\mu$ F | 335 |
|   | Ld  | .025 nom. | (.635 nom.)   | 500 VDC                | .070 $\mu$ F | 703                    | 1.10 $\mu$ F | 115 |
| <br><b>H06</b> | W   | .870 max. | (22.1 max.)   | 25 VDC                 | .750 $\mu$ F | 754                    | 22.0 $\mu$ F | 226 |
|   | H   | .600 max. | (15.2 max.)   | 50 VDC                 | .620 $\mu$ F | 624                    | 17.0 $\mu$ F | 176 |
|   | T   | .200 max. | (5.08 max.)   | 100 VDC                | .560 $\mu$ F | 564                    | 13.0 $\mu$ F | 136 |
|   | S   | .790 nom. | (20.1 nom.)   | 200 VDC                | .360 $\mu$ F | 364                    | 8.00 $\mu$ F | 805 |
|   | Ld  | .032 nom. | (.813 nom.)   | 500 VDC                | .240 $\mu$ F | 244                    | 2.90 $\mu$ F | 295 |

# SWITCH-MODE RADIAL LEADED CAPACITORS

| CASE SIZE   | In. | (mm)      | RATED VOLTAGE | NPO CAPACITANCE (MAX.) |              | X7R CAPACITANCE (MAX.) |              |     |
|---|-----|-----------|---------------|------------------------|--------------|------------------------|--------------|-----|
|   |     |           |               |                        |              |                        |              |     |
| <br>H07  | W   | 1.10 max. | (27.9 max.)   | 25 VDC                 | .680 $\mu$ F | 684                    | 35.0 $\mu$ F | 356 |
|   | H   | .600 max. | (15.2 max.)   | 50 VDC                 | .560 $\mu$ F | 564                    | 28.0 $\mu$ F | 286 |
|   | T   | .200 max. | (5.08 max.)   | 100 VDC                | .470 $\mu$ F | 474                    | 19.0 $\mu$ F | 196 |
|   | S   | .980 nom. | (24.9 nom.)   | 200 VDC                | .330 $\mu$ F | 334                    | 13.0 $\mu$ F | 136 |
|   | Ld  | .032 nom. | (.813 nom.)   | 500 VDC                | .200 $\mu$ F | 204                    | 4.60 $\mu$ F | 465 |
| <br>H08  | W   | 1.10 max. | (27.9 max.)   | 25 VDC                 | 1.20 $\mu$ F | 125                    | 70.0 $\mu$ F | 706 |
|   | H   | .600 max. | (15.2 max.)   | 50 VDC                 | 1.10 $\mu$ F | 115                    | 56.0 $\mu$ F | 566 |
|   | T   | .350 max. | (8.89 max.)   | 100 VDC                | .820 $\mu$ F | 824                    | 37.0 $\mu$ F | 376 |
|   | S   | .980 nom. | (24.9 nom.)   | 200 VDC                | .470 $\mu$ F | 474                    | 26.0 $\mu$ F | 266 |
|   | Ld  | .032 nom. | (.813 nom.)   | 500 VDC                | .300 $\mu$ F | 304                    | 8.70 $\mu$ F | 875 |
| <br>H09  | W   | .670 max. | (17 max.)     | 25 VDC                 | .450 $\mu$ F | 454                    | 13.0 $\mu$ F | 136 |
|   | H   | .540 max. | (13.7 max.)   | 50 VDC                 | .360 $\mu$ F | 364                    | 10.0 $\mu$ F | 106 |
|   | T   | .200 max. | (5.08 max.)   | 100 VDC                | .330 $\mu$ F | 334                    | 7.20 $\mu$ F | 725 |
|   | S   | .575 nom. | (14.6 nom.)   | 200 VDC                | .240 $\mu$ F | 244                    | 5.00 $\mu$ F | 505 |
|   | Ld  | .025 nom. | (.635 nom.)   | 500 VDC                | .180 $\mu$ F | 184                    | 1.70 $\mu$ F | 175 |
| <br>H10 | W   | .930 max. | (23.6 max.)   | 25 VDC                 | 1.00 $\mu$ F | 105                    | 38.0 $\mu$ F | 386 |
|   | H   | .720 max. | (18.3 max.)   | 50 VDC                 | .900 $\mu$ F | 904                    | 30.0 $\mu$ F | 306 |
|   | T   | .250 max. | (6.35 max.)   | 100 VDC                | .750 $\mu$ F | 754                    | 20.0 $\mu$ F | 206 |
|   | S   | .800 nom. | (20.3 nom.)   | 200 VDC                | .470 $\mu$ F | 474                    | 14.0 $\mu$ F | 146 |
|   | Ld  | .032 nom. | (.813 nom.)   | 500 VDC                | .300 $\mu$ F | 304                    | 5.80 $\mu$ F | 585 |

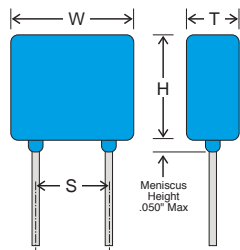

NOTE: Lead lengths are typically 1.25" for orders in bulk packaging. Leads are typically 1.00" for tape and reel packaging. Tape and reel packaging comes in 1000 piece reels.

## HOW TO ORDER SWITCH-MODE RADIALS

Part number written: 201H07W105KQ4

|   |             |                    |   |  |                           |                               |  |
|---|-------------|--------------------|---|--|---------------------------|-------------------------------|--|
| <b>201</b>  | <b>H07</b>  | <b>W</b>           | <b>105</b>  | <b>K</b>   | <b>Q</b>                  | <b>4</b>                      |  |
| <b>VOLTAGE</b>  | <b>SIZE</b> | <b>DIELECTRIC</b>  | <b>CAPACITANCE</b>  | <b>TOLERANCE</b>   | <b>TERMINATION</b>        | <b>MARKING</b>                | <b>PACKING</b>   |
| 250 = 25 V<br>500 = 50 V<br>101 = 100 V<br>201 = 200 V<br>501 = 500 V | See Chart   | N = NPO<br>W = X7R | 1st two digits are significant; third digit denotes number of zeros.<br>101 = 100 pF<br>102 = 1000 pF<br>103 = 0.01 $\mu$ F<br>105 = 1.00 $\mu$ F | J = $\pm$ 5%<br>K = $\pm$ 10%<br>M = $\pm$ 20%<br>Z = +80%<br>-20% | Q = Leaded & Encapsulated | 4 = Standard<br>3 = Specified | T = Tape and Reel<br>H = High Rel<br>Testing per customer requirements<br>S = Special Part |



# HIGH VOLTAGE RADIAL LEADED CAPACITORS

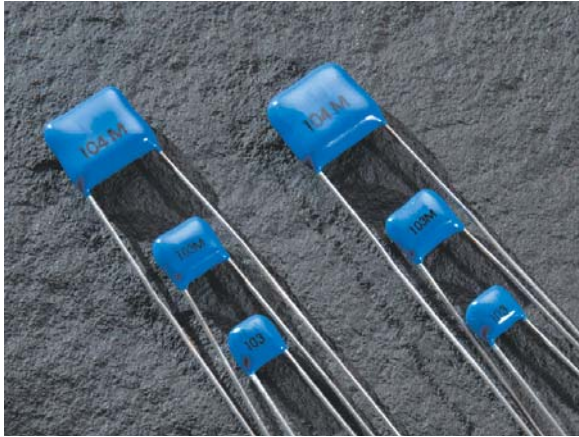





## KEY FEATURES

- Rated Working Voltages from 25 to 500 VDC
- Rugged Epoxy Coating Offers Increased Protection
- Compact MLC Designs Smaller Than Film or Disc
- **NEW 200°C & 250°C** Versions Available for Oil & Geophysical Tool, Aircraft Engine Control Applications
- DSCC Drawing & Other Screened Versions Available

## ADVANTAGES

- Power Supplies
- Voltage Multipliers
- Data Isolation
- Surge Protection
- Industrial Control Circuits
- Custom Applications



## CASE SIZE

|   | In. | (mm)        | RATED VOLTAGE | NPO CAPACITANCE (MAX.) |         | X7R CAPACITANCE (MAX.) |         |     |
|---|-----|-------------|---------------|------------------------|---------|------------------------|---------|-----|
|   |     |             |               |                        |         |                        |         |     |
| <br><b>H42</b>  | W   | 0.250 Max   | (6.35 Max)    | 500 VDC                | 4700 pF | 472                    | .150 μF | 154 |
|   | H   | 0.220 Max   | (5.59 Max)    | 1000 VDC               | 1500 pF | 152                    | .055 μF | 553 |
|   | T   | 0.270 Max   | (6.86 Max)    | 2000 VDC               | 680 pF  | 681                    | 9000 pF | 902 |
|   | S   | 0.170 ±0.03 | (4.32 ±0.76)  | 3000 VDC               | 330 pF  | 331                    | 2800 pF | 282 |
|   | Ld  | 0.025 ±.002 | (0.64 ±0.05)  | 4000 VDC               | 150 pF  | 151                    | 630 pF  | 631 |
|   |     |             |               | 5000 VDC               | 100 pF  | 101                    | 550 pF  | 531 |
| <br><b>H47</b> | W   | 0.370 Max   | (9.40 Max)    | 500 VDC                | .022 μF | 223                    | .480 μF | 484 |
|   | H   | 0.300 Max   | (7.62 Max)    | 1000 VDC               | 3300 pF | 332                    | .170 μF | 174 |
|   | T   | 0.270 Max   | (6.86 Max)    | 2000 VDC               | 1500 pF | 152                    | .025 μF | 253 |
|   | S   | 0.275 ±0.03 | (6.99 ±0.76)  | 3000 VDC               | 680 pF  | 681                    | .011 μF | 113 |
|   | Ld  | 0.025 ±.002 | (0.64 ±0.05)  | 4000 VDC               | 330 pF  | 331                    | 1800 pF | 182 |
|   |     |             |               | 5000 VDC               | 220 pF  | 221                    | 940 pF  | 941 |
| <br><b>H51</b> | W   | 0.470 Max   | (12.0 Max)    | 500 VDC                | .056 μF | 563                    | 1.20 μF | 125 |
|   | H   | 0.400 Max   | (10.2 Max)    | 1000 VDC               | 4700 pF | 472                    | .450 μF | 454 |
|   | T   | 0.320 Max   | (8.13 Max)    | 2000 VDC               | 3300 pF | 332                    | .094 μF | 943 |
|   | S   | 0.375 ±0.03 | (9.53 ±0.76)  | 3000 VDC               | 1500 pF | 152                    | .043 μF | 433 |
|   | Ld  | 0.025 ±.002 | (0.64 ±0.05)  | 4000 VDC               | 1000 pF | 102                    | .010 μF | 103 |
|   |     |             |               | 5000 VDC               | 470 pF  | 471                    | 4900 pF | 492 |
| <br><b>H62</b> | W   | 0.570 Max   | (14.5 Max)    | 500 VDC                | .100 μF | 104                    | 2.20 μF | 225 |
|   | H   | 0.500 Max   | (12.7 Max)    | 1000 VDC               | .010 μF | 103                    | .804 μF | 804 |
|   | T   | 0.320 Max   | (8.13 Max)    | 2000 VDC               | 6800 pF | 682                    | .240 μF | 244 |
|   | S   | 0.475 ±0.03 | (12.1 ±0.76)  | 3000 VDC               | 3300 pF | 332                    | .073 μF | 733 |
|   | Ld  | 0.025 ±.002 | (0.64 ±0.05)  | 4000 VDC               | 2200 pF | 222                    | .028 μF | 283 |
|   |     |             |               | 5000 VDC               | 1000 pF | 102                    | .013 μF | 133 |
| <br><b>H66</b> | W   | 0.670 Max   | (17.0 Max)    | 500 VDC                | .150 μF | 154                    | 3.30 μF | 335 |
|   | H   | 0.600 Max   | (15.2 Max)    | 1000 VDC               | .015 μF | 153                    | 1.20 μF | 125 |
|   | T   | 0.320 Max   | (8.13 Max)    | 2000 VDC               | .010 μF | 103                    | .440 μF | 444 |
|   | S   | 0.575 ±0.03 | (14.6 ±0.76)  | 3000 VDC               | 4700 pF | 472                    | .013 μF | 134 |
|   | Ld  | 0.025 ±.002 | (0.64 ±0.05)  | 4000 VDC               | 3300 pF | 332                    | .041 μF | 413 |
|   |     |             |               | 5000 VDC               | 2200 pF | 222                    | .020 μF | 203 |





# HIGH VOLTAGE RADIAL LEADED CAPACITORS

| CASE SIZE  | CASE SIZE |                                    | RATED VOLTAGE | NPO CAPACITANCE (MAX.) |     | X7R CAPACITANCE (MAX.) |     |
|--|-----------|------------------------------------|---------------|------------------------|-----|------------------------|-----|
|  | In.       | (mm)                               |               |                        |     |                        |     |
| <br>H70 | W         | 0.770 Max (19.6 Max)               | 500 VDC       | .220 $\mu$ F           | 224 | 5.70 $\mu$ F           | 575 |
|  | H         | 0.720 Max (18.3 Max)               | 1000 VDC      | .022 $\mu$ F           | 223 | 2.10 $\mu$ F           | 215 |
|  | T         | 0.320 Max (8.13 Max)               | 2000 VDC      | .015 $\mu$ F           | 153 | .620 $\mu$ F           | 624 |
|  | S         | 0.675 $\pm$ 0.03 (17.1 $\pm$ 0.76) | 3000 VDC      | 6800 pF                | 682 | .190 $\mu$ F           | 194 |
|  | Ld        | 0.025 $\pm$ .002 (0.64 $\pm$ 0.05) | 4000 VDC      | 4700 pF                | 472 | .054 $\mu$ F           | 543 |
|  |           |                                    | 5000 VDC      | 3300 pF                | 332 | .026 $\mu$ F           | 263 |
| <br>H72 | W         | 0.870 Max (22.1 Max)               | 500 VDC       | .330 $\mu$ F           | 334 | 7.30 $\mu$ F           | 735 |
|  | H         | 0.750 Max (19.1 Max)               | 1000 VDC      | .100 $\mu$ F           | 104 | 2.80 $\mu$ F           | 285 |
|  | T         | 0.320 Max (8.13 Max)               | 2000 VDC      | .056 $\mu$ F           | 563 | .800 $\mu$ F           | 804 |
|  | S         | 0.775 $\pm$ 0.03 (19.7 $\pm$ 0.76) | 3000 VDC      | .033 $\mu$ F           | 333 | .250 $\mu$ F           | 254 |
|  | Ld        | 0.025 $\pm$ .002 (0.64 $\pm$ 0.05) | 4000 VDC      | .010 $\mu$ F           | 103 | .080 $\mu$ F           | 803 |
|  |           |                                    | 5000 VDC      | 6800 pF                | 682 | .041 $\mu$ F           | 413 |
| <br>H80 | W         | 1.450 Max (36.8 Max)               | 500 VDC       | .470 $\mu$ F           | 474 | 12.0 $\mu$ F           | 126 |
|  | H         | 0.720 Max (18.3 Max)               | 1000 VDC      | .150 $\mu$ F           | 154 | 4.60 $\mu$ F           | 465 |
|  | T         | 0.320 Max (8.13 Max)               | 2000 VDC      | .082 $\mu$ F           | 823 | 1.20 $\mu$ F           | 125 |
|  | S         | 1.375 $\pm$ 0.03 (34.9 $\pm$ 0.76) | 3000 VDC      | .047 $\mu$ F           | 473 | .390 $\mu$ F           | 394 |
|  | Ld        | 0.025 $\pm$ .002 (0.64 $\pm$ 0.05) | 4000 VDC      | .015 $\mu$ F           | 153 | .130 $\mu$ F           | 134 |
|  |           |                                    | 5000 VDC      | .010 $\mu$ F           | 103 | .068 $\mu$ F           | 683 |

## T-SERIES 200°C & 250°C

Johanson also offers two different series of high temperature radial leaded capacitors for 200°C and 250°C. These components feature rugged pre-molded cases with Hi-Temp epoxy fill. The 200°C line is offered in voltage ratings of 25V to 4KV and maximum capacitance loss of -0.5% in NPO and -45% in X7R. The 250°C line is offered in voltage ratings of 50V & 100V with maximum capacitance loss of -1.5% in NPO and -55% in X7R. Please visit our website for complete component selection & specifications

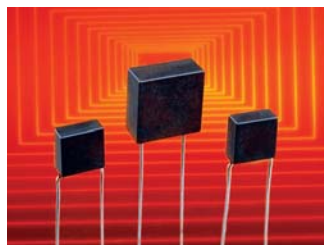

### APPLICATIONS

- Oil Well Logging (Downhole)
- Geophysical Probes
- Jet Engine Controls

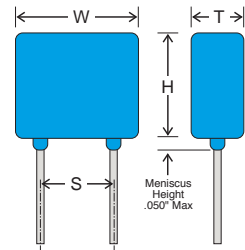

NOTE: Lead lengths are typically 1.25" for orders in bulk packaging. Leads are typically 1.00" for tape and reel packaging. Tape and reel packaging comes in 1000 piece reels.

## HOW TO ORDER HIGH VOLTAGE RADIALS

Part number written: 102H42W101KQ4

| 102  | H42       | W                  | 101   | K  | Q                         | 4                             |  |
|--|-----------|--------------------|---|--|---------------------------|-------------------------------|--|
| VOLTAGE  | SIZE      | DIELECTRIC         | CAPACITANCE   | TOLERANCE  | TERMINATION               | MARKING                       | PACKING  |
| 501 = 500 V<br>102 = 1000 V<br>202 = 2000 V<br>302 = 3000 V<br>402 = 4000 V<br>502 = 5000 V* | See Chart | N = NPO<br>W = X7R | 1st two digits are significant; third digit denotes number of zeros.<br>102 = 1000 pF<br>103 = 0.01 $\mu$ F<br>105 = 1.00 $\mu$ F | J = $\pm$ 5%<br>K = $\pm$ 10%<br>M = $\pm$ 20%<br>Z = +80%<br>-20% | Q = Leaded & Encapsulated | 4 = Standard<br>3 = Specified | T = Tape and Reel<br>H = High Rel<br>Testing per customer requirements<br>S = Special Part |



# CAPACITOR PACKAGING

Johanson capacitors are available taped per EIA standard 481. Tape options include 7" and 13" diameter reels. Johanson uses high quality, dust free, punched 8mm paper tape and plastic embossed 8mm tape for thicker MLCCs. Quantity per reel ranges are listed in the tables below and are dependent on chip thickness.

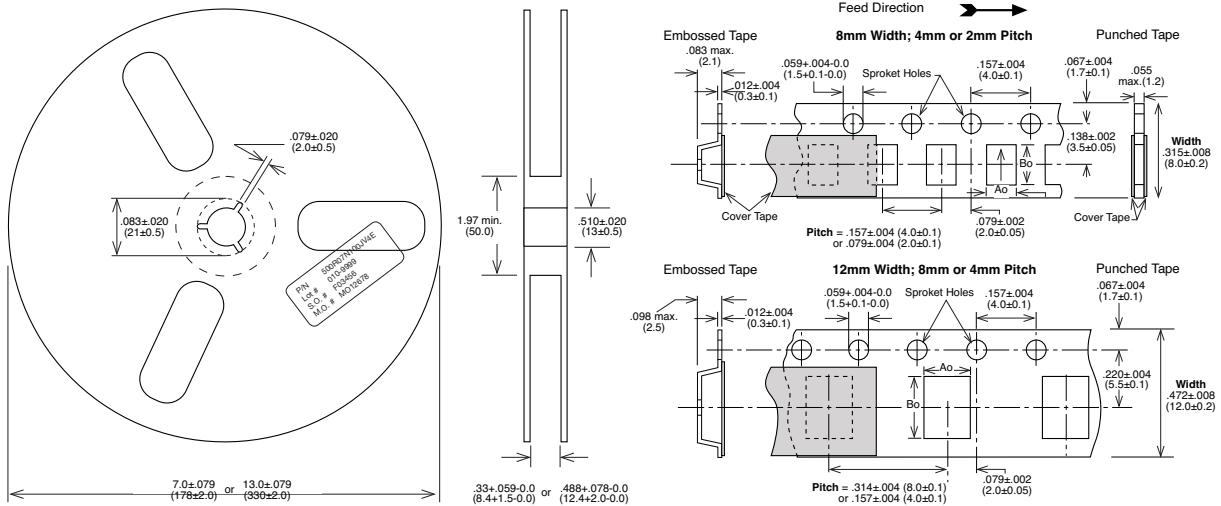
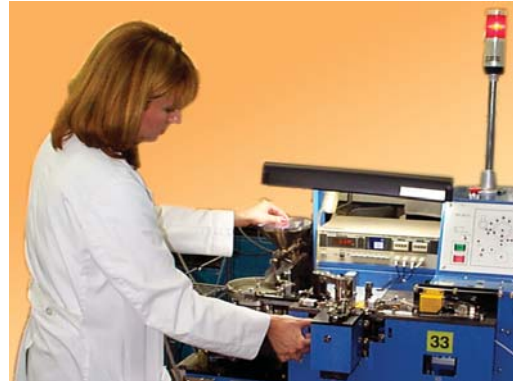

| COMPONENT       | 7" DIAMETER REEL |                  |               |       | 13" DIAMETER REEL |                  |               |       |
|-----------------|------------------|------------------|---------------|-------|-------------------|------------------|---------------|-------|
|                 | REEL QTY         | TAPE TYPE        | WIDTH / PITCH | CODE  | REEL QTY          | TAPE TYPE        | WIDTH / PITCH | CODE  |
| R05 / 0201 MLCC | 15000            | Paper            | 8mm/2mm       | T     | N/A               | N/A              |               | N/A   |
| R07 / 0402 MLCC | 10000            | Paper            | 8mm/2mm       | T     | N/A               | N/A              |               | N/A   |
| R14 / 0603 MLCC | 4000             | Paper            | 8mm/4mm       | T     | 10000             | Paper            | 8mm/4mm       | R     |
| R15 / 0805 MLCC | 4000 / 3000      | Paper / Embossed | 8mm/4mm       | T / E | 10000             | Paper / Embossed | 8mm/4mm       | R / U |
| R18 / 1206 MLCC | 4000 / 3000      | Paper / Embossed | 8mm/4mm       | T / E | 10000             | Paper / Embossed | 8mm/4mm       | R / U |
| S41 / 1210 MLCC | 2000 - 4000      | Embossed         | 8mm/4mm       | E     | 5000-10000        | Embossed         | 8mm/4mm       | U     |
| R29 / 1808 MLCC | 2000             | Embossed         | 12mm/4mm      | E     | 5000 - 8000       | Embossed         | 12mm/4mm      | U     |
| R30 / 2211 MLCC | 1000 - 2000      | Embossed         | 12mm/4mm      | E     | 2000 - 5000       | Embossed         | 12mm/4mm      | U     |
| S43 / 1812 MLCC | 500 - 1000       | Embossed         | 12mm/8mm      | E     | 3000 - 5000       | Embossed         | 12mm/8mm      | U     |
| S47 / 2220 MLCC | 250 - 1000       | Embossed         | 12mm/8mm      | E     | 2000 - 5000       | Embossed         | 12mm/8mm      | U     |
| S49 / 1825 MLCC | 250 - 1000       | Embossed         | 12mm/8mm      | E     | 2000 - 4000       | Embossed         | 12mm/8mm      | U     |
| S48 / 2225 MLCC | 250 - 1000       | Embossed         | 12mm/8mm      | E     | 2000 - 4000       | Embossed         | 12mm/8mm      | U     |
| X07 / 0402 X2Y  | 4000             | Paper            | 8mm/2mm       | T     | 10000             | Paper            | 8mm/2mm       | R     |
| X14 / 0603 X2Y  | 4000             | Paper            | 8mm/4mm       | T     | 10000             | Paper            | 8mm/4mm       | R     |
| X15 / 0805 X2Y  | 4000             | Embossed         | 8mm/4mm       | E     | 10000             | Embossed         | 8mm/4mm       | U     |
| X18 / 1206 X2Y  | 3000 - 4000      | Embossed         | 8mm/4mm       | E     | 10000             | Embossed         | 8mm/4mm       | U     |
| X41 / 1210 X2Y  | 2000 - 3000      | Embossed         | 8mm/4mm       | E     |                   |                  |               |       |
| X44 / 1410 X2Y  | 1000 - 2000      | Embossed         | 8mm/4mm       | E     |                   |                  |               |       |
| X43 / 1812 X2Y  | 1000             | Embossed         | 12mm/8mm      | E     |                   |                  |               |       |

Actual reel quantities based on part thickness and tape type. Contact sales for reel quantities of specific part numbers.

# ELECTRICAL CHARACTERISTICS

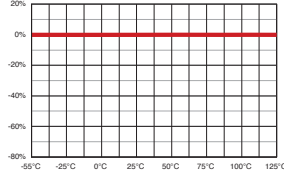
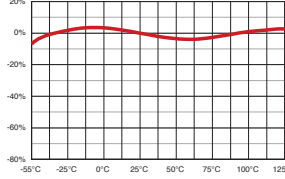
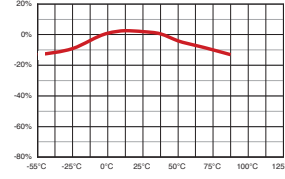
| PARAMETER                | NPO  |               | X7R   |               | X5R   |              |
|--------------------------|--|---------------|---|---------------|---|--------------|
| TEMPERATURE COEFFICIENT: | 0± 30 ppm/°C   | -55 to +125°C | ± 15%   | -55 to +125°C | ± 15%   | -55 to +85°C |
|                          |   |               |   |               |  |              |
| DISSIPATION FACTOR:      | .001 (0.1%) max  |               | WVDC ≥ 50 VDC, DF = 2.5% max<br>WVDC = 25 VDC, DF = 3.0% max<br>WVDC = 16 VDC, DF = 3.5% max                                |               | For Vrated ≥ 50 VDC, DF = 5% max<br>For Vrated ≤ 25 VDC: DF = 10% max               |              |
| AGING:                   | None   |               | 2.5% / decade hour  |               | 2.5 % / decade hour   |              |
| INSULATION RESISTANCE:   | 1000ΩF or 100GΩ<br>whichever is less @ 25°C, WVDC  |               | 500ΩF or 50GΩ<br>whichever is less @ 25°C, WVDC   |               | 100ΩF or 10GΩ<br>whichever is less @ 25°C, WVDC                                     |              |
| DIELECTRIC STRENGTH:     | For Vrated = 6 - 200 VDC, DWV = 2.5 X WVDC, 25°C, 50mA max.<br>For Vrated = 201 - 499 VDC, DWV = 2.0 X WVDC, 25°C, 50mA max.<br>For Vrated = 500 - 999 VDC, DWV = 1.5 X WVDC, 25°C, 50mA max.<br>For Vrated = 1000+ VDC, DWV = 1.2 X WVDC, 25°C, 50mA max. |               |   |               | DWV = 2.5 X WVDC, 25°C, 50mA max.   |              |
| TEST PARAMETERS:         | C > 100 pF; 1kHz ±50Hz; 1.0±0.2 VRMS<br>C ≤ 100 pF 1Mhz ±50kHz; 1.0±0.2 VRMS   |               | 1kHz ±50Hz; 1.0±0.2 VRMS  |               | 1kHz ±50Hz; 0.5±0.2 VRMS  |              |
| NOTES:                   |  |               | Tanceram IR = 100 ΩF or 10 GΩ<br>Tanceram DF for Vrated ≥ 50 VDC = 5% max.<br>Tanceram DF for Vrated ≤ 25 VDC, DF = 10% max |               |   |              |

## PART NUMBER BREAKDOWN

Part number written: 500R15N101JV4T

| 500  | R15  | N                             | 101  | J   | V   | 4  | T  |
|--|--|-------------------------------|--|---|---|--|--|
| VOLTAGE  | SIZE   | DIELECTRIC                    | CAPACITANCE  | TOLERANCE   | TERMINATION   | MARKING  | PACKING  |
| 6R3 = 6.3 V<br>100 = 10 V<br>160 = 16 V<br>250 = 25 V<br>500 = 50 V<br>101 = 100 V<br>201 = 200 V<br>251 = 250 V<br>301 = 300 V<br>501 = 500 V<br>631 = 630 V<br>102 = 1000 V<br>202 = 2000 V<br>302 = 3000 V<br>402 = 4000 V<br>502 = 5000 V<br>ACJ = 250 VAC | R05=0201<br>R07=0402<br>R14=0603<br>R15=0805<br>A18=0612<br>R18=1206<br>S41=1210<br>R29=1808<br>R30=2011<br>S43=1812<br>S47=2220<br>S49=1825<br>S48=2225<br>X07=0402 X2Y<br>X14=0603 X2Y<br>X15=0805 X2Y<br>X18=1206 X2Y<br>X41=1210 X2Y<br>X44=1410 X2Y<br>X43=1812 X2Y | N = NPO<br>W = X7R<br>X = X5R | 1st two digits are significant; third digit denotes number of zeros, R = decimal.<br><br>100 = 10 pF<br>102 = 1,000 pF<br>474 = 0.47 μF<br>475 = 4.7 μF<br>106 = 10 μF | * B = ± 0.10 pF<br>* C = ± 0.25 pF<br>* D = ± 0.50 pF<br><br>F = ± 1 %<br>G = ± 2 %<br>J = ± 5 %<br>K = ± 10 %<br>M = ± 20 %<br>Z = +80 -20 %<br><br>*Values < 10 pF only | V = Nickel Barrier with 100% Tin Plating (Matte)<br><br>F = Polyterm flexible termination<br><br>T = SnPb<br><br>P = PdAg | 3 = Special (J)<br>4 = Unmarked<br>6 = EIA Code*<br><br>*Not available on sizes ≥ 0402 | E = Embossed 7"<br>T = Punched 7"<br>U = Embossed 13"<br>R = Punched 13"<br><br>No code = bulk pack<br><br>Tape specifications conform to EIA RS481<br><br>Not all tape styles are available on all parts. |

PLEASE NOTE: Not all combinations of JDI P/Ns are valid. Please refer to the appropriate "How to Order" section for a particular product or contact your Sales Representative if you need assistance.



# *Your Technology Partner*



High Voltage

AC Safety



X2Y

Tanceram



Low Voltage

Tin-Lead



High Temperature

AC Power



Feedthru Filter

Low ESL



SMPS

Radial Leaded



## CORPORATE HEADQUARTERS

15191 Bledsoe Street  
Sylmar, California 91342  
Tel (818) 364-9800 • FAX (818) 364-6100  
<http://www.johansondielectrics.com>



## JOHANSON HONG KONG LTD.

Unit E, 11/F, Phase 1, Kaiser Estate  
41 Man Yue Street  
Hungghom, Kowloon, Hong Kong  
Tel: (852) 2334 6310 • Fax: (852) 2334 8858



Компания «ЭлектроПласт» предлагает заключение долгосрочных отношений при поставках импортных электронных компонентов на взаимовыгодных условиях!

Наши преимущества:

- Оперативные поставки широкого спектра электронных компонентов отечественного и импортного производства напрямую от производителей и с крупнейших мировых складов;
- Поставка более 17-ти миллионов наименований электронных компонентов;
- Поставка сложных, дефицитных, либо снятых с производства позиций;
- Оперативные сроки поставки под заказ (от 5 рабочих дней);
- Экспресс доставка в любую точку России;
- Техническая поддержка проекта, помощь в подборе аналогов, поставка прототипов;
- Система менеджмента качества сертифицирована по Международному стандарту ISO 9001;
- Лицензия ФСБ на осуществление работ с использованием сведений, составляющих государственную тайну;
- Поставка специализированных компонентов (Xilinx, Altera, Analog Devices, Intersil, Interpoint, Microsemi, Aeroflex, Peregrine, Syfer, Eurofarad, Texas Instrument, Miteq, Cobham, E2V, MA-COM, Hittite, Mini-Circuits, General Dynamics и др.);

Помимо этого, одним из направлений компании «ЭлектроПласт» является направление «Источники питания». Мы предлагаем Вам помощь Конструкторского отдела:

- Подбор оптимального решения, техническое обоснование при выборе компонента;
- Подбор аналогов;
- Консультации по применению компонента;
- Поставка образцов и прототипов;
- Техническая поддержка проекта;
- Защита от снятия компонента с производства.



#### Как с нами связаться

**Телефон:** 8 (812) 309 58 32 (многоканальный)

**Факс:** 8 (812) 320-02-42

**Электронная почта:** [org@eplast1.ru](mailto:org@eplast1.ru)

**Адрес:** 198099, г. Санкт-Петербург, ул. Калинина, дом 2, корпус 4, литера А.