

# Compact fans for AC and DC

version 2014

**ebmpapst**

The engineer's choice



# Trendsetter in fan technology

*Uncompromising quality made by ebm-papst*



## **Among the best.**

Trendsetting with innovative technologies. Listening to customers' needs. Developing new ideas to meet requirements and realising them with pioneering spirit. This philosophy has made ebm-papst the technological leader in the world of fans.

A brand which has very little real competition because every fan is a product of decades of application expertise gained from large-volume production and because we are in a position to produce highly efficient quality products. Our intelligent solutions for electronics cooling ensure that you are one step ahead of competitors thanks to innovative, reliable top-quality technology which is cost-favourable and in line with market requirements. And if required, tailor-made right down to the last detail. In other words, if you need fans which do not yet actually exist, contact us.

Insist on ebm-papst.

# Table of contents

<b>Information</b>		<b>ACmaxx / GreenTech EC-Compact fans</b>	<b>179</b>
– The company	4	– Axial fans	184
– GreenTech: The Green Company	6	<b>AC axial fans</b>	<b>201</b>
– Expertise and technology	8	– Axial fans	204
– Tailor-made	10	<b>AC centrifugal fans</b>	<b>227</b>
– Optional special designs	12	– Centrifugal fans	230
– Types of fans	13	<b>Accessories</b>	<b>237</b>
– Selecting the correct fan	14	– Guard grilles	238
– Fan installation	15	– Filter guard grilles	246
– Service life	17	– Inlet nozzles	248
– Definitions	18	– Connection cables	251
– Type code	19	– Handheld programmer	252
		– Accessories	253
<b>DC axial fans</b>	<b>25</b>	– Electrical connections	254
– Axial fans	31	<b>ebm-papst representatives &amp; subsidiaries</b>	<b>260</b>
<b>DC centrifugal fans</b>	<b>89</b>		
– Centrifugal fans	93		
– Tangential blowers	134		
– Centrifugal fans and blowers	136		
<b>DC fans - specials</b>	<b>161</b>		
– Speed signal	164		
– Alarm signal	168		
– Vario-Pro®	173		
– Speed setting	174		
– Protected fans, Type of protection: IP 54 / IP 68	177		



## Company profile: ebm-papst

*The entire scope of ventilation and drive technology: this is the world of ebm-papst. More than 11.000 people – in Germany and throughout the world – develop, produce and sell our motors and fans. Our global presence and our unique range of products based on a quality standard that surpasses every other have made us what we are: world market leader in motors and fans. Expertly knowing what our customers need and incessantly striving to arrive at the perfect application solution for a wide variety of different industries is what determines our daily work.*

*Those who know us know the high standards we apply to our work and know our creed: to be as close to our customers as possible and to simply be the best in terms of innovation and reliability.*





### **Our history – Our drive**

Rooted in ebm, PAPST and mvl, the three leading innovators in the development and production of motors and fans, ebm-papst has established itself as the world market leader. Now as ever, our legendary inventive spirit shines through in products that set standards in many segments of industry worldwide. We are proud to say that despite difficult competition, our performance has always been exemplary and outstanding – in business, in our personal relationship with our customers, and of course with respect to technology and engineering. For decades, we have contributed to the world of air technology and drive engineering with small revolutions and large milestones.

To maintain this advantage in skills and knowledge to get maximum quality and thus the highest degree of customer satisfaction, our employees around the world put their passion and dedication to work for you.

### **Passionately involved in R&D**

Our catalogues just list the results of our incessant efforts in R&D: products of highest quality and reliability. After all, it is our passion to constantly try something new and improve what we have. In doing so, we take advantage of the latest development methods and state-of-the-art technology and invest quite heavily in R&D facilities. Best of all, though, we rely on excellently trained and skilled engineers and technicians to be at your service in R&D and Sales & Distribution.

### **Producing and safeguarding high-quality products and services**

This is our promise without any compromise. Whether produced in one of our six factories in Germany or one of our eleven international production sites, our products always have the same high level of quality. This quality control is something you can definitely rely on! And this across all levels of production and throughout all processes: consulting customers,

development, material selection through to picking certified, choice suppliers and on to the production of parts and final delivery. On top of this, our products have to pass the most rigorous tests under all realistic operating conditions: continuous stress test, salt spray test, vibration test, or precision noise measuring, just to mention a few. And the product gets clearance for serial production only after all the desired characteristics have been determined to be just right.

Environmental care is another priority with ebm-papst. This is why we have developed our product line in EC technology, which makes for very low power consumption. Due to our manufacturing philosophy, there is absolute focus on environmental care in production, recycling, waste and wastewater disposal.

### **Global Domestic**

In order to be specialist for customised solutions throughout the world, you need strong partners. Global Domestic – i.e. being present all over the world and being a national company in each individual country – is how we have established ourselves in all important markets on this globe with our successful subsidiaries. And so you will always find ebm-papst close to home, speaking your language, and knowing the demands of your markets. Besides, our worldwide production alliance serves as a basis for competitive pricing. Our global services and logistic outlets, i.e. IT networking, safeguard short reaction times and just-in-time delivery.

All our efforts are documented in a comprehensive quality management system, both for products and services. Being certified as complying with the tough requirements of the international standards DIN EN ISO 9001, ISO/TS 16949-2 and of standard DIN EN ISO 14001 is just one seal of approval we have received for our unceasing efforts to provide only the best quality products and services.

# Sustainability is at the centre of our thoughts and actions. Out of conviction!

*Eco-friendliness and sustainability have always been at the core of our thoughts and actions. For decades, we have worked according to the simple but strict creed of our co-founder Gerhard Sturm: "Each new product we develop has to be better than the last one in terms of economy and ecology." GreenTech is the ultimate expression of our corporate philosophy.*

## **GreenTech is pro-active development.**

Even in the design phase, the materials and processes we use are optimised for the greatest possible eco-friendliness, energy balance and – wherever possible – recyclability. We continually improve the material and performance of our products, as well as the flow and noise characteristics. At the same time, we significantly reduce energy consumption. Close co-operation with universities and scientific institutes and the professorship we endow in the area of power engineering and regenerative energies allows us to profit from the latest research findings in these fields – and at the same time ensure highly qualified young academics.

## **GreenTech is eco-friendly production.**

GreenTech also stands for maximum energy efficiency in our production processes. There, the intelligent use of industrial waste heat and groundwater cooling, photovoltaics and, of course, our own cooling and ventilation technology are of the utmost importance. Our most modern plant, for instance, consumes 91% less energy than currently specified and required. In this way, our products contribute to protecting the environment, from their origin to their recyclable packaging.



**GreenTech is acknowledged and certified.**

Every step in our chain of production meets the stringent standards of environmental specialists and the public.

This supports our position as Germany's most sustainable company 2013, as does the DEKRA Award 2012 we received in the category "Umwelt – Herausforderung Energiewende / Environment – Challenge: Transition to more sustainable energy systems", to name only a few of a large number of examples. The environmental advantage gained in the performance of the products developed from our GreenTech philosophy can also be measured in the fulfillment of the most stringent energy and environmental standards. In many instances, our products are already well below the thresholds energy legislation will impose a few years from now – several times over.

**Our customers profit from this every day.**

The heart of GreenTech is future-oriented EC technology from ebm-papst. The EC technology at the core of our most efficient motors and fans allows efficiency of up to 90%, saves energy at a very high level, significantly extends service life and makes our products maintenance-free. These values pay off not only for the environment, but every cent also pays off for the user! All ebm-papst products – even those for which GreenTech EC technology does not (yet) make sense from an application viewpoint – feature the greatest possible connection of economy and ecology.



GreenTech means  
ecologically improving  
every new product.

# Expertise and technology

## Drive expertise

For the past 60 years, all conceivable types and applications of drive engineering have played an essential role at ebm-papst. A commitment that is the foundation for the development of optimum drive solutions – regardless of the type of fan and its usage. DC fans are generally equipped with electronically commutated external rotor motors; in order to save as much space as possible, commutation electronic components are integrated in the hub of the fan. Our AC fans are mostly driven by shaded-pole or capacitor motors based on the external rotor principle. In the 3900 and 9900 range of particularly slim fans, internal rotor motors are used.

## Low-noise performance

Our aerodynamically optimised design and high mechanical precision produces outstanding noise properties in series production. So-called “soft” commutation electronics of the DC fans ensure an excellent noise performance. By avoiding steep switching edges when the individual coils are switched, this reduces the structure-borne noise from the motor. Computer-aided measurements and series of analyses performed in a state-of-the-art sound measuring chamber are conducted on each fan model from the very beginning.

## Long service life

The bearing system plays a vital role both in the long life time and quietness of device fans. The SINTEC compact bearing provides most of the device fans with a proven bearing system. Constant low noise during the entire operating time and considerably lower shock sensitivity are the outstanding features of this bearing technology. In addition, with regard to temperature endurance, Sintec compact bearings can be used without problems in most applications. Despite the slightly higher noise and shock sensitivity of ball bearings, this bearing technology should be given preference for fans exposed to extreme thermal and adverse application conditions (e.g. extreme environmental conditions, critical installation position, etc.). The service life data provided in this catalogue is based on extensive service life tests and mathematically / scientifically proven service life calculations. Our product descriptions are continuously updated with all relevant data obtained from long-term tests.







### Streamline: Aerodynamics

With the aid of state-of-the-art computer programs, we are able to optimise the fan impellers and the inner shape of the housing. Air output and available motor performance are exactly matched with the size of fan. This guarantees the low noise that is typical for ebm-papst, even at high back pressure.

### Sturdy construction – in metal or plastic

Fans of all-metal construction: Sturdy and resistant. The housing is made of an aluminium alloy whereas the metal surfaces that are subject to corrosion are permanently protected by an impact- and abrasion-resistant electrophoretic baked enamel. This particular version is highly recyclable. Fans with fibreglass-reinforced plastic housing and impeller: Excellent stability and low weight distinguish this highly efficient fan concept. Combinations of metal housing and plastic impeller unite the advantages of both types of design.

### Product images

The dimensioned drawings and product photos that appear in the catalogue are for orientation purposes and may differ in some details from the actual product design.

### Product liability

Motors and fans from ebm-papst are components intended for proper installation. The customer bears responsibility for the overall end product.

### Safety is included



It goes without saying that all ebm-papst fans conform to the approval requirements of the VDE (Association of German Electrical Engineers) and the standards and regulations of UL and CSA. All fans conform to the European Standard EN 60335 or EN 60950 plus those of the UL (Underwriters Laboratories) and CSA (Canadian Standards Association). With few exceptions, our DC fans are designed to meet the requirements of protection class 3 / protection class voltage. AC fans are protection class 1. ebm-papst fans meet the highest requirements of electrical safety. All design variants feature reverse polarity and locked rotor protection.

### Quality in detail

It is in the important details where the motto "made by ebm-papst" comes into its own: Consistent adherence to development and design processes and a targeted commitment to quality along the entire process chain are the foundation for the fans' above-average service life. 100.000 hours and above are now possible.

The no-compromise ebm-papst quality assurance spans over all process levels – from the choice of materials and the use of carefully selected, certified suppliers, from the production of parts up to final assembly. These details combine to result in reliable fan products with an above-average service life.

### ErP guidelines



All products with power consumption between 125 W and 500 kW are subject to the European "Energy-related Products Directive" (ErP) for improving energy efficiency, with the first stage coming into force from 2013 and the second as of 2015. Thanks to ground-breaking GreenTech EC technology, all of our fans and motors in these performance classes already exceed the ErP Directive today.

# Tailor-made to meet your special requirements

## ***Practice-oriented: Fans – customised and intelligent***

*ebm-papst has always developed customer-specific intelligent fans which meet the exact requirements of the application. We provide a wide range of standard fan types, in many sizes and designs; with intelligent motor features, monitoring and control functions as well as special designs for use under extreme conditions. They are all based on the standard type fans which you will find in this catalogue. Special fan types for your application can be produced in economical batch sizes. Our expert engineers will assist you in selecting the right configuration.*

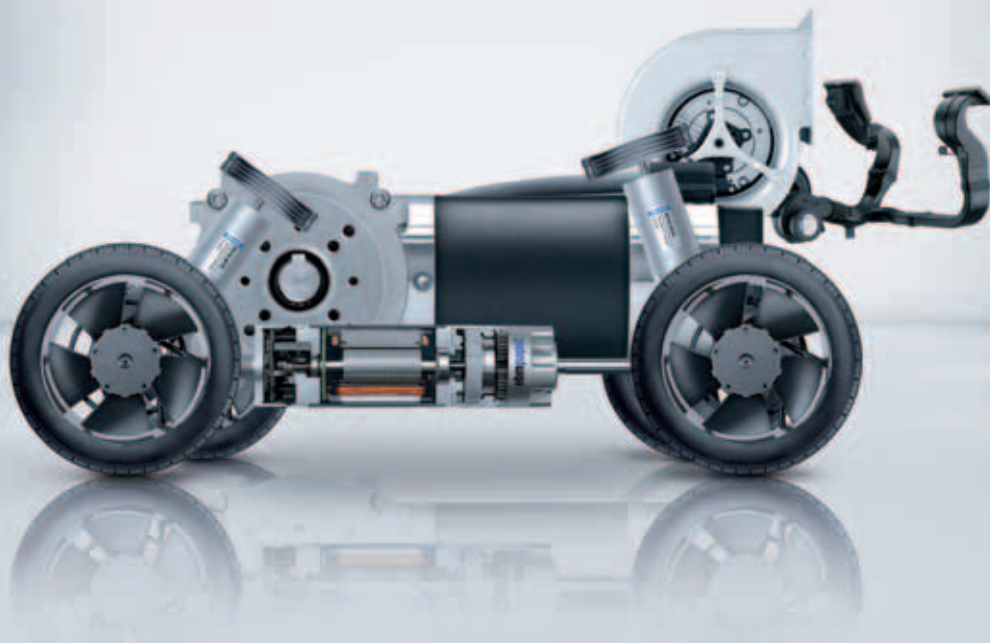



### **Innovation at its best:**

Vario-Pro® with “intelligence inside”. Its programmed intelligence thanks to customer-specifically configured software modules makes the cooling of electronics even more economical and flexible. For example, temperature-dependent speed profiles are possible with a number of freely selectable interpolation points. External speed settings and a variety of combinable alarm and tachometer functions can also be programmed. The digital motor management achieves high control accuracy.

### **Higher type of protection for every type of application**

ebm-papst provides, on request, many fan series in versions which conform to the requirements of type of protection IP 54 and IP 68: Their stator and all electrical components are fully encapsulated. Stainless steel ball bearings can be used for operation in particularly aggressive media and use under extreme environmental conditions, thus providing additional reliability.

### **Virtually everything is possible**

Regardless of your cooling and ventilation tasks, we develop the right solution and what is more, the most economical one. Based on the fans listed in this catalogue, well over 4000 different versions are available.

### **Temperature-controlled fans**

Fans with temperature-controlled speed have particularly quiet cooling characteristics. Thanks to integrated IC technology, they adapt their speed to the current cooling requirements, which results in a drastic reduction of noise in most operating modes. A temperature sensor provides the fan with thermal information: either externally via a single lead or integrated into the hub of the fan.

### **Speed setting via interfaces**

With a wide range of DC fans with separate control input, ebm-papst provides an alternative to the NTC-controlled types of fans. They are especially suitable for systems and units which already have standard interfaces for varying speed via internal switching and control circuits.

The main applications are units which demand load-dependent individual speed profiles or systems with stand-by minimum cooling requirements and varied speed increase at varying power peaks.

### **“Electronic tachometer” thanks to sensor signal**

Do you wish to be informed about the current fan speed at all times? ebm-papst has fans with an integrated “electronic tachometer” which registers the actual value of the fan speed. Via an integrated sensor, the fan generates speed-dependent signals which can be directly utilised. Depending on the number of poles of the motor, 2, 3 or 6 pulses per revolution are generated.

### **Alarm signal for more safety**

If your application requires monitored fan operation, in addition to speed monitoring, ebm-papst also provides a multitude of varying alarm signals. Depending on the type of fan in question, the signal is either static, already evaluated or interface-compatible. The alarm signal output provides reliable longterm monitoring and a status signal if critical operating conditions evolve.

### **S-Force**

The new measure of things!  
When you need to provide extremely fast, powerful and efficient cooling for electronic components of all kinds, the generation of S-Force high-performance fans finishes first: in air performance, pressure build-up and technology. Extremely efficient drives and optimised aerodynamics form the core technology of the S-Force fans, which we offer in both an axial and brand-new centrifugal model.

### **S-Panther**

S-Panther power delivered quietly. Wherever there is need for power and reduced noise, fans from the S-Panther range are the right solution. A strong pressure saddle curve at optimum air flow provides the power of a real big cat.

# Optional special versions

(see chapter DC fans - specials)

In the catalogue, a text box in the upper right corner provides information on the special designs which are technically possible in the fan range.

Please note that these special versions are not possible for all voltages and speeds, and not in all combinations. The special versions are designed for specific customers and projects and are not usually available off the shelf.

max. 44 m <sup>3</sup> /h	<b>DC axial fans</b> Series 630 60 x 60 x 25 mm	
	<ul style="list-style-type: none"><li>- <b>Material:</b> Housing: GRP<sup>1</sup> (PBT) Fan impeller: GRP<sup>1</sup> (PA)</li><li>- <b>Direction of air flow:</b> Exhaust via struts</li><li>- <b>Direction of rotation:</b> Clockwise as seen on rotor</li><li>- <b>Connection:</b> Via single strands AWG 22, TR 64</li><li>- <b>Highlights:</b> Developed for applications with demanding environmental requirements</li><li>- <b>Ground:</b> 70 g</li></ul>	<ul style="list-style-type: none"><li>- <b>Possible special versions:</b> (See chapter DC fans - specials)</li><li>- Speed signal</li><li>- Go / No-go alarm</li><li>- Alarm with limit speed</li><li>- External temperature sensor</li><li>- PWM control input</li><li>- Analogue control input</li><li>- Protection against moisture</li><li>- Protection against salt spray fog</li><li>- Type of protection: IP 54 / IP 68</li></ul>

Possible special designs are depicted on the catalogue page.

## Speed signal /2, /12

The fan uses a separate wire to output information about its speed, and thus about the speed of the rotor. For technical details, please refer to page 164 ff.

## Go / No-go alarm /37, /39

The fan uses a separate wire to output a static signal when it is stationary, thus providing information about whether or not the rotor is turning. For technical details, please refer to page 171 f.

## Alarm with limit speed /17, /19

If one of the speeds defined in the fan electronics is not met, the fan conveys via a static signal that the set limit speed has not been met. For technical details, please refer to page 168 ff.

## External temperature sensor

A NTC resistor (negative temperature coefficient) is attached to the fan via a separate wire and the fan changes its speed depending on the temperature on the NTC. For technical details, please refer to page 174.

## Internal temperature sensor

In this case, the NTC is integrated into the fan and the fan changes its speed depending on the temperature at the NTC. For technical details, please refer to page 174.

## PWM control input

The speed of the fan can be changed via a pulse-width-modulated signal. This signal is applied to a specially provided wire. For technical details, please refer to page 175.

## Analogue control input

The speed of the fan can be changed via a control voltage. This control voltage is applied to a specially provided wire. For technical details, please refer to page 175.

## Multi-option control input

The fan has a control input that the user can trigger either using a PWM signal, an analogue signal or a resistor. For technical details, please refer to page 176.

## Protection against moisture

Protection for the fan's electronics against moisture and condensation. For technical details, please refer to page 177.

## Type of protection IP 54 / IP 68

Protection of motor and PCB board against splashed water and humidity. For technical details, please refer to page. 177.

## Protection against salt fog

Protection of fan against the damaging effects of salt fog. For technical details, please refer to page 177.

## Direction of rotation

On many variants, the direction of rotation can be changed via a control input.

# Types of fans and their function



## **Axial fans:**

### **High air flow with medium to relatively high pressure build-up**

The air flow in axial fans, whose impeller is similar to that of a propeller, is conducted to a great extent parallel to the axis of rotation, in other words in the axial direction. Axial fans with free air delivery at zero static pressure have the lowest power input that rises with increasing back pressure. Axial fans for cooling of electronic equipment are mostly equipped with external housing and an electric motor integrated into the fan hub. This compact design allows space-saving accommodation of all devices; the flange is equipped with mounting holes.



## **Diagonal fans:**

### **High flow rate at relatively high pressure build-up**

At first glance diagonal fans only differ slightly from axial fans. Intake is axial, whereas exhaust is diagonal. Due to the conical shape of the wheel and housing, the air is pressurised more. In direct comparison with axial fans of the same size and comparable performance, these fans are distinguished by the lower operating noise at high pressures.

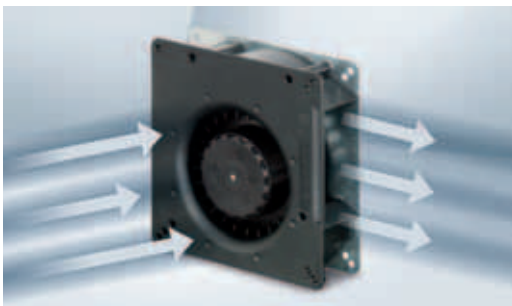

## **Centrifugal fans:**

### **High pressure build-up at limited flow rate**

Many of the cooling problems that occur can be optimally solved by axial and/or diagonal fans. If, for example, the required cooling air has to be conducted at an angle of 90° or if even high pressure is necessary, centrifugal fans are more effective. For your application, ebm-papst offers not only complete centrifugal fans but also motor/impeller combinations without external housing.

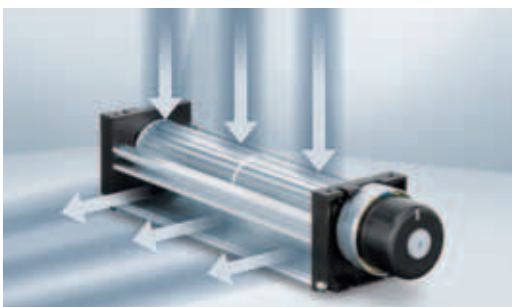

## **Tangential fans:**

### **High flow rate at low pressure**

Tangential fans are used above all-, for large-surface air flow in devices. The air flows through the roller-shaped impellers twice in the radial direction: in the intake area from the outside to the inside and in the outflow area from the inside to the outside. Whirls form in the roller due to the vanes which guarantee a steady flow of air through the impeller.

# Selecting the correct fan

## 1. Dissipated energy

A large amount of the energy consumed by electrical and electronic devices is converted into heat. In selecting the correct fan, therefore, it is important to determine the dissipated energy that must be removed. The electrical power consumption of the unit to be cooled, often represents a suitable value for this purpose.

## 2. Permissible temperature rise

The air flow which the selected fan is required to generate, is determined by the dissipated energy and the permissible rise ( $\Delta T$ ) of the cooling air flow (from entry to exit of the device to be cooled). The max. allowable  $\Delta T$  depends greatly on the temperature sensitivity of the individual device components.

$\Delta T = 5K$  means e.g. that the average air flow leaving the device to be cooled may only be  $5^{\circ}C$  warmer than the ambient temperature (a large volume of air is required for this purpose). A lower air flow rate is sufficient if a higher temperature difference (e.g.  $\Delta T = 20K$ ), can be tolerated.

## 3. Required cooling air flow

- In the below diagram a horizontal line is drawn from the dissipated energy to intersect with the selected  $\Delta T$  line.
- Read down from this point to obtain the required value for the cooling air flow. The diagram is based on the following formula:

$$\dot{V} [\text{m}^3/\text{h}] \approx 3 \cdot \frac{P_v [\text{W}]}{\Delta T [\text{K}]}$$

## 4. Optimum operating range

The required fan, however, must also be able to deliver a suitable static pressure increase  $\Delta p_f$ , in order to force the cooling air through the device. A fan must therefore be selected that provides the required air flow performance within its optimum operating range (see also the air performance curves under technical data).

## 5. Fan selection

If the requirements of an application are fulfilled by more than one fan, the noise level, space requirements, economy and ambient conditions will assist in making the final choice.

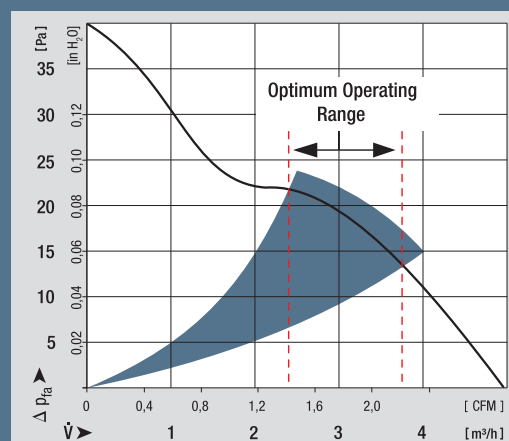
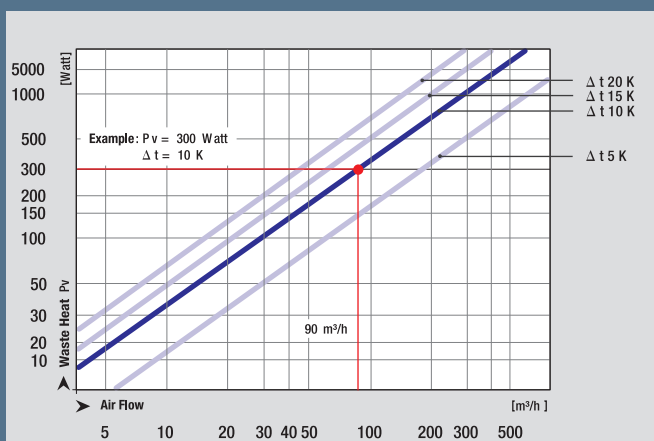

# Fan installation

## Intake or exhaust side installation

Under ideal conditions, the operating point is represented as the intersection between the fan and loss curves, regardless of whether the fan is positioned at the air intake or exhaust side of the device. In addition to ensuring the required flow rate, several additional aspects must be considered for determining an appropriate fan concept. The intake air currents of a fan are mainly laminar, comprising nearly the entire suction area. By contrast, the exhaust air of a fan is generally turbulent, while it flows on a preferred direction, e.g. axial for an axial fan. The turbulences of the exhaust intensify the heat transfer from components within the air currents, so that mounting the fan at the air intake side of the device is recommended for cooling and heating. Mounting the fan at the device intake is also advantageous because the fan will not be subjected to the dissipated heat of the device. Therefore, it operates at low ambient temperatures and has a higher life expectancy.

## Information on installation

When a fan is operated for the first time in an application, the user may have noticed that the flow rate in the device was lower than expected. What is the reason for this?

- The values stated in this catalogue were determined under optimum, constant and comparable measurement conditions.
- Ideal mounting conditions under which free air intake and exhaust are present are seldom feasible in practice. Quite frequently the fans must be mounted in close proximity to other components or cabinet panels. As a consequence, the intake and exhaust currents may be restricted, causing the air flow to diminish and the noise level to increase. Fans are particularly sensitive to obstructions which are positioned directly in front of the output cross section as they often cause an increase in tonal noise.

**Our advice:** The distance between the fan and adjacent components should be at least equal to the installation depth of the fan.

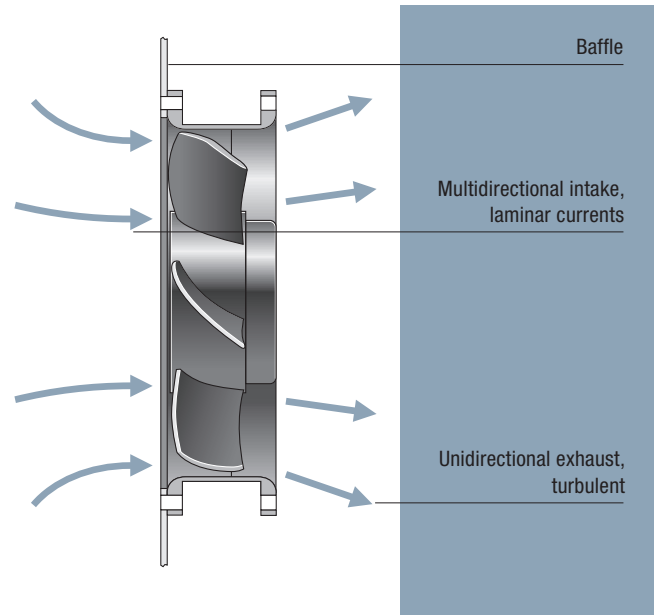

### Accident prevention



The turning rotor and the high speeds that are sometimes involved mean that our fan products carry an inherent risk of injury. They may only be operated after correct installation and with suitable protective facilities (e.g. with a guard grille). More information can be found in the internet at: [www.ebmpapst.com/safety](http://www.ebmpapst.com/safety)

# Connection instructions for S-Force fans



## Special features of S-Force fans

The S-Force series is the most powerful product series on the market. S-Force stands for the highest innovation in motor technology, fluid mechanics and electronics. The one-of-a-kind power density of the products requires special attention to the application at the customer's facility.

## Service life

Due to the high currents in the fans, the load on the electrolyte capacitors is greater, which reduces the service life of the capacitor. As a larger or additional capacitor cannot be housed in the fan, the capacitor must be housed in the supply line.

If the power pack of the application has a corresponding capacitor, in some cases it may be possible to omit the external capacitor.

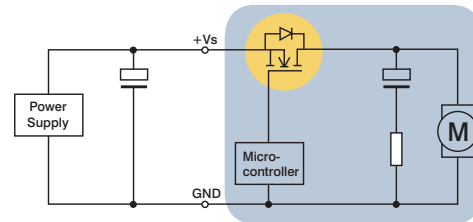

Recommended measure: Additional external capacitor (thus must be installed as close to the fan as possible < 30 cm).

Fan	Capacitor required
<b>S-Force axial</b>	
8200 / 3200 JH3-JH4	no
4100 NH3 / NH4 / NH5 / NH6	no
4100 NH7 / NH8	yes
5300 / 5300 TD	no
6300 / 6300 TD	no
2200 FTD	no
<b>S-Force centrifugal</b>	
RET 97 TD	yes
RER 120 TD	yes
RER 133 TD	no
RER 160 NTDHH / RG 160 NTDHH	yes
REF 175 TD	no
RER 175 TD	no
RER 190 TD / RG 190 TD	no
RER 220 TD / RG 220 TD	no
RER 225 TDM / RG 225 TDM	no
RER 225 TD / RG 225 TD	no

## Recommended capacitors

We recommend using the following capacitors from Rubycon:

24 VDC:

50 ZL 680  $\mu\text{F}$ ; 12,5 mm x 30 mm or

50 ZLH 680  $\mu\text{F}$  12,5 mm x 30 mm

48 VDC:

100 YXG 470  $\mu\text{F}$ ; 16 mm x 35,5 mm or

100 ZLH 470  $\mu\text{F}$  16 mm x 31,5 mm

Other capacitors with equal or greater capacitance and equal or lower serial resistance can also be used.

ebm-papst St. Georgen offers the following capacitors ex stock:

24 VDC: 1000  $\mu\text{F}$  / 50 V, 16 mm x 25 mm

Art. No.: 992 0345 000 (LZ 354)

48 VDC: 680  $\mu\text{F}$  / 100 V, 18 mm x 40 mm

Art. No. : 992 0355 000 (LZ 355)



# Service life

## Service life data from ebm-papst St. Georgen

Our fans catalogue gives three different values for the service life of each product. The first column usually states the service life  $L_{10}$  at 40°C. the second column usually states the service life  $L_{10}$  at  $T_{max}$ . Exceptions are marked in the column headings. The third column states the new value, life expectancy  $L_{10IPC}$  (40 °C).

Bell(A)	Sound power level Surface sleeve bearings Ball bearings	Power consumption Watts	Nominal speed RPM	Temperature range °C	Service life $L_{10}$ (40°C) ebm-papst Standard Hours	Service life $L_{10}$ ( $T_{max}$ ) ebm-papst Standard Hours	Life expectancy $L_{10IPC}$ (40°C) see page 17 Hours	Curve
5,2	■	1,8	5 900	-20...+70	85 000 / 42 500	142 500	①	
5,4	■	1,5	6 300	-20...+70	85 000 / 42 500	142 500	②	

Example of the service life figures on the catalogue page.

## Service life $L_{10}$ (40 °C) and $L_{10}$ ( $T_{max}$ )

The values given in the first two columns have been derived from intensive, in-house service life endurance tests, in which our products are operated in various positions at 40°C and 70°C until they fail. A fan is deemed to have failed when it deviates from its defined air flow and speed values, or when the operating noise becomes noticeable. Such tests can take several years before a representative number of failures have been registered, and even today, some fans are still in the process of endurance testing, even though they began tests in the 1980s. These fans are proof of the legendary "made by ebm-papst" reliability.

Test results are presented in a diagram and the service life of the product  $L_{10}$  at the temperature tested is determined on the basis of the Weibull distribution.

These tests have given us years of experience in the way various design parameters and temperatures can affect the service life of a product. Data for service life at various temperatures for new products can be stated with a very high degree of precision on the basis of tests, product specifications and of commonalities in the design of the product.

## New: Life expectancy $L_{10IPC}$ (40 °C)

The new third service life column states the expected service life  $L_{10IPC}$ . This information is based on the international norm IPC 9591. Again here, the foundations for the service life values are our service life endurance tests at high ambient temperatures. The service life at temperatures below the test temperatures is calculated using fixed factors. This method produces much higher service life values, especially at room temperature (see diagram on right).

## Summary:

The life span calculations have been carried out to the best of our knowledge and are based on experience gained by ebm-papst. The specified  $L_{10}$  (40 °C),  $L_{10}$  ( $T_{max}$ ) and  $L_{10IPC}$  (40 °C) values all allow statements to be made about the theoretical calculated service life under certain assumptions. The values determined here are extrapolations from our own service life tests and from statistical variables. In the respective customer applications, different influences may occur which cannot be included in the calculations due to their complexity. The service life information is explicitly not a guarantee of service life, but strictly a theoretical quality figure.



Fans in an endurance test cabinet at ebm-papst St. Georgen. 1500 fans are operated in temperature cabinets until they fail.

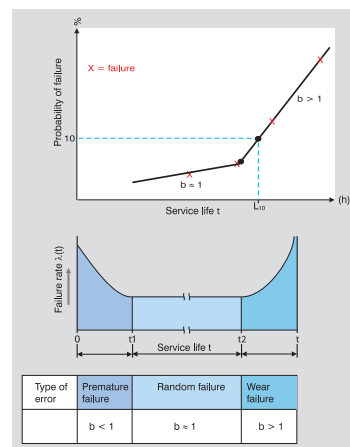

Bathub curve and Weibull distribution.

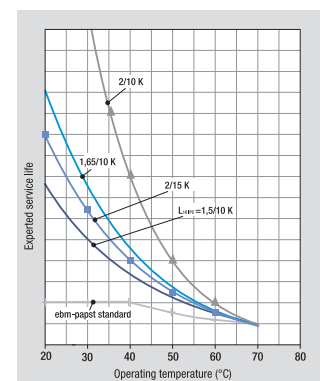

Example of the influence of factors from various manufacturers on the expected service life.

# Definitions

## Nominal voltage (Volts)

The voltage at which the nominal values (the tabular values listed in this catalogue) were determined. The fan operation for DC fans is not limited to the nominal voltage. Fan speed and fan performance can vary according to the permissible voltage range that is specified on the nameplate of each fan. Be aware here that this is not a pulsed or modulated DC voltage.

## Frequency (Hz)

ebm-papst AC fans are made for operating frequencies of 50 Hz or 60 Hz. Their technical data alter accordingly.

## Air flow [m<sup>3</sup>/h]

The air performance of the fan in free air operation, i.e. the fan blows into the free space without static pressure build-up.

## Fan curves

The fan curves are determined in accordance with DIN ISO 5801 specifications on a dual-chamber test stand with intake-side measurement. This measurement technique closely approximates the operating conditions experienced in typical applications for fans and yields realistic performance curves. The curves apply to an air density of  $\rho = 1.2 \text{ kg/m}^3$ , corresponding to an air pressure of 1013 mbar at 20 °C. Variations in air density affect pressure

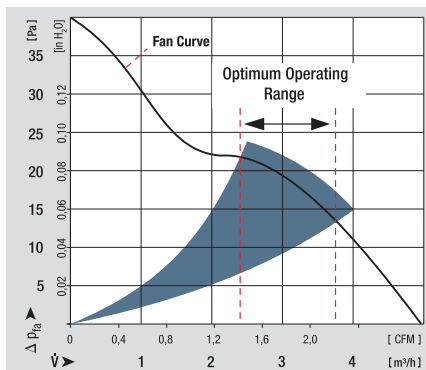

generation but not the flow rate. The pressure generated at other air densities may be estimated with the formula  $\Delta p_2 = \Delta p_1 (\rho_2 / \rho_1)$ . The nominal speed values, air flow and power input listed in the table were measured in free air operation with horizontal shaft at an ambient temperature of 20 +5 °C, air density  $\rho = 1.2 \text{ kg/m}^3$  after a warm-up period of 5 min.

## Optimum operating range

During operation, fans are required to produce an air flow with a simultaneous increase of pressure. These operating conditions are described in the section “Optimum Operating Range”. The optimum operating range is therefore always indicated in this catalogue in the shaded area. In this range the fans operate best with respect to efficiency and noise level. Within this optimum operating range the noise level only fluctuates insignificantly.

## Noise [dB(A), Bel(A)]

### 1. Sound pressure level – dB(A)

Noise ratings of the fan in free air operation, i.e. at maximum flow rate.

### 2. Sound power level – Bel(A) / dB(A)

Extent of the overall sound radiation of the fan. The sound power level is determined in the optimum operating range.

## PAPST Sintec® sleeve bearings

A particularly efficient bearing system with excellent qualities:

- Very precise, large sintered bearings
- Low running noise
- High service life expectancy
- Insensitive to shock and vibration

## Ball bearings

Precision ball bearings for particularly high ambient temperatures and high service life expectancy.

## Input power [Watts]

Input performance of the fan motor when operating free blowing at nominal voltage. Depending on the operating condition in the application, the power input may be higher.

## Temperature range [°C]

The permissible ambient temperature range within which the fan can be expected to run continuously.

## Service life [h]

### Service life L<sub>10</sub> at 40 °C and T<sub>max</sub>

Standard figures for service life at ebm-papst. These two temperatures are based on intensive, in-house endurance tests and on the experience more than 60 years developing fans.

### Life expectancy L<sub>10IPC</sub> (40 °C)

Information calculated in line with the norm IPC 9591. Data based on the internal expected service life at 70°C, more optimistically extrapolated to 40°C.

**We expressly state that none of the information or data in this catalogue is to be construed as a guarantee or warranty of properties.**

## Unit conversion

Air flow	Pressure
1 cfm = 1,7 m <sup>3</sup> /h	1 Pa = 1x10 <sup>-5</sup> bar
1 l/s = 3,6 m <sup>3</sup> /h	1 inch H <sub>2</sub> O = 249 Pa
1 l/min = 0,06 m <sup>3</sup> /h	1 mm H <sub>2</sub> O = 9,81 Pa

Subject to technical alterations.

Our products are not designed for use in the aerospace industry!

German and international patents, registered designs and utility models.

ebm-papst is a registered trademark of ebm-papst Mulfingen GmbH & Co. KG.

PAPST, SINTEC, VARIOFAN and Vario-Pro are registered trademarks of ebm-papst St. Georgen GmbH & Co. KG.

## Type code

## 3-digit DC axial fan e.g. 412 FM

Housing dimensions (W x H x D)		
Value	Edge dimensions (W x H)	Installation depth (D)
2	25 x 25 mm	8 mm
<b>4</b>	<b>40 x 40 mm</b>	<b>10 / 20 / 25 / 28 mm</b>
5	50 x 50 mm	15 mm
6	60 x 60 mm	15 / 25 / 32 mm
7	70 x 70 mm	15 mm

Operating voltage	
Value	Nominal voltage
<b>2</b>	<b>12 V</b>
4	24 V
5	5 V
8	48 V

Motor and housing version	
Value	Version
<b>1</b>	<b>4xx fan, 10 / 20 / 25 / 28 mm (D)</b>
1	6xx fan, 15 / 25 / 32 mm (D)
2	25 / 28 mm (D)
3	63x fan, 25 mm (D)
5	2xx fan, 8 mm (D)

## Options (various versions possible)

A	Analogue speed control input (input voltage: 0...5 / 0...10 V DC)
D	Reinforced flange corners with through-holes (Series 44xx F) Constant speed control independent from operating voltage
E	Economy fan with round flange
<b>F</b>	<b>Flat construction / frequency-modulated signal</b>
G	Sleeve bearing
H	High speed
HH	Further increased speed
H3-H8	Additional further increased speeds (H8 - maximum fan speed)
I	Integrated temperature sensor (NTC behaviour, i.e. thermistor)
J	Jet characteristic / rigid curve
L	Low speed
<b>M</b>	<b>Medium speed</b>
ML	Between low and medium speed
N	Standard or basic speed (only DC fans)
O	Multi-option speed control input (analogue or PWM signal)
P	PWM speed control input (pulse-width modulated signal)
R	Moisture protection coating Circuit board and winding (IP 20), optional stainless steel ball bearing
S	Speed signal (additional wires for hall signal, obsolete technology)
T	External temperature sensor (NTC behaviour, i.e. thermistor)
TD	Turbo drive (extremely powerful 3-phase motor)
U	Environmentally friendly fan (min. IP 54)
V / VP	VARIOFAN
W	Additional wires (standard length 310 mm)
X	Mounting bore hole 3.7 mm
-xxx	Variant number

## 4-digit DC axial fan, e.g. 4312 GM

Housing dimensions (W x H x D)		
Value	Edge dimensions (W x H)	Installation depth (D)
2	∅ 220 x 200 mm	51 mm
3	92 x 92 mm	25 / 32 / 38 mm
<b>4</b>	<b>119 x 119 mm</b>	<b>25 / 32 / 38 mm</b>
5	127 x 127 mm	38 mm
5	135 x 135 mm	38 mm
5	140 x 140 mm	51 mm
6	∅ 172 mm	51 mm
6	∅ 172 x 150 / 160 mm	51 mm
7	∅ 150 mm	38 / 55 mm
8	80 x 80 mm	25 / 32 / 38 mm

## Connection type and direction of rotation

Value	Connection type	Direction of rotation
<b>1</b>	<b>Wires, length = 310 mm</b>	
5	Wires, length = 310 mm	
6	Plug, 2.8 x 0.8 mm	Counter-clockwise (CCW)
7	Plug, 2.8 x 0.8 mm	Clockwise (CW)
8	Plug, 2.8 x 0.5 mm	Counter-clockwise (CCW)
9	Plug, 2.8 x 0.5 mm	Clockwise (CW)

Motor and housing version	
Value	Version
1	38 mm (D)
2	38 mm (D)
<b>3</b>	<b>32 mm (D)</b>
4	25 / 38 / 51 mm (D)

Operating voltage	
Value	Nominal voltage
<b>2</b>	<b>12 V</b>
4	24 V
6	36 V
8	48 V

## Options (various versions possible)

A	Analogue speed control input (input voltage: 0...5 / 0...10 V DC)
D	Reinforced flange corners with through-holes (Series 44xx F) Constant speed control independent from operating voltage
DV	Diagonal Venturi fan
E	Economy fan with round flange
F	Flat construction / frequency-modulated signal
<b>G</b>	<b>Sleeve bearing</b>
H	High speed
HH	Further increased speed
H3-H8	Additional further increased speeds (H8 - maximum fan speed)
I	Integrated temperature sensor (NTC behaviour, i.e. thermistor)
J	Jet characteristic / rigid curve
L	Low speed
<b>M</b>	<b>Medium speed</b>
ML	Between low and medium speed
N	Standard or basic speed (only DC fans)
O	Multi-option speed control input (analogue or PWM signal)
P	PWM speed control input (pulse-width modulated signal)
R	Moisture protection coating Circuit board and winding (IP 20), optional stainless steel ball bearing
S	Speed signal (additional wires for hall signal, obsolete technology)
T	External temperature sensor (NTC behaviour, i.e. thermistor)
TD	Turbo drive (extremely powerful 3-phase motor)
U	Environmentally friendly fan (min. IP 54)
V / VP	VARIOFAN
W	Additional wires (standard length 310 mm)
X	Mounting bore hole 3.7 mm
-xxx	Variant number

All dimensions in millimetres [mm].

# Type code

## DC centrifugal fan e.g. RER 160-28/12 N

Type	Housing and fan impeller versions
	Housing Impeller blade design
RE	None Non-curved, no direction of rotation set
REF	None Forwards/backwards-curved impeller blades, flat
<b>RER</b>	<b>None Backwards-curved impeller blades</b>
RET	None Forwards-curved impeller blades
RG	Square Forwards/backwards-curved impeller blades
RL	Round Forwards-curved impeller blades
RLF	Round Forwards/backwards-curved impeller blades, flat
RV	Round Forwards-curved impeller blades

Height fan impeller blade

Options (various versions possible)	
A	Analogue speed control input (input voltage: 0...5 / 0...10 V DC)
D	Reinforced flange corners with through-holes (Series 44xx F) Constant speed control independent from operating voltage
E	Economy fan with round flange
F	Flat construction / frequency-modulated signal
G	Sleeve bearing
H	High speed
HH	Further increased speed
H3-H8	Additional further increased speeds (H8 - maximum fan speed)
I	Integrated temperature sensor (NTC behaviour, i.e. thermistor)
J	Jet characteristic / rigid curve
L	Low speed
M	Medium speed
ML	Between low and medium speed
<b>N</b>	<b>Standard or basic speed (only DC fans)</b>
O	Multi-option speed control input (analogue or PWM signal)
P	PWM speed control input (pulse-width modulated signal)
R	Moisture protection coating Circuit board and winding (IP 20), optional stainless steel ball bearing
S	Speed signal (additional wires for hall signal, obsolete technology)
T	External temperature sensor (NTC behaviour, i.e. thermistor)
TD	Turbo drive (extremely powerful 3-phase motor)
U	Environmentally friendly fan (min. IP 54)
V / VP	VARIOFAN
W	Additional wires (standard length 310 mm)
X	Mounting bore hole 3.7 mm
-xxx	Variant number

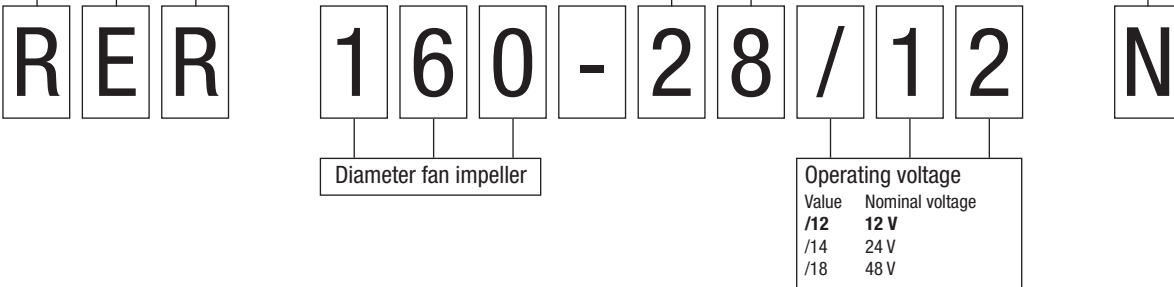

## Tangential blower e.g. QG 030-148/12

Type	Housing and fan impeller versions
	Housing Impeller blade design
<b>QG</b>	<b>Round Compressor drum</b>

Housing dimensions (W x H)			
Value	Edge dimensions (W x H)	Impeller length	Total length
148	48 x 50 mm	148 mm	201 mm
198	48 x 50 mm	198 mm	258 mm
303	48 x 50 mm	303 mm	363 mm
353	48 x 50 mm	353 mm	413 mm

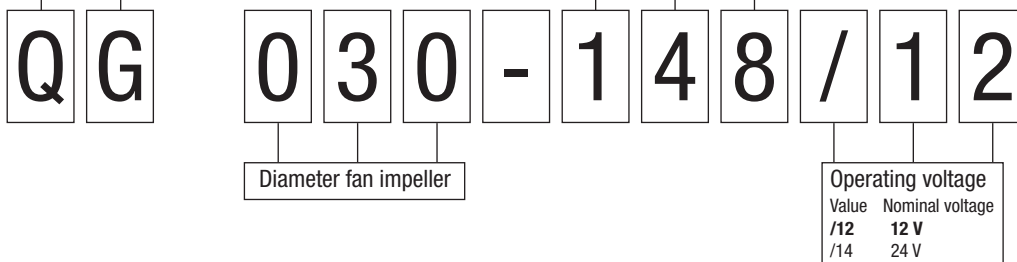

All dimensions in millimetres [mm].

## Type code

## 4-digit GreenTech EC compact fans axial e.g. ACi 4420 HH

Housing dimensions (W x H x D)			Operating voltage				Options (various versions possible)	
Value	Edge dimensions (W x H)	Installation depth (D)	Value	Nominal voltage	Frequency	Design		
1	Ø 98,5 mm	130 mm	0	115 / 230 V	50 / 60 Hz	Wide voltage range input (85-265 V AC)		
3	92 x 92 mm	38 mm	1	115 V	50 Hz			
<b>4</b>	<b>119 x 119 mm</b>	<b>25 / 32 / 38 mm</b>	<b>2</b>	<b>230 V</b>	<b>50 Hz</b>			
6	Ø 172	51 mm						
8	80 x 80 mm	32 mm						

Basic design		Motor and housing version		Bearing type and insulation class	
Value	Design	Value	Version	Value	Insulation class
AC	DC basic fan with integrated AC/DC power supply unit	0	130 mm (D)	0	Ball bearing E
<b>ACi</b>	<b>EC technology (electronics completely integrated)</b>	1	51 mm (D)		
		2	38 / 51 mm (D)		
		3	32 mm (D)		
		<b>4</b>	<b>25 / 38 mm (D)</b>		

Options (various versions possible)	
A	Analogue speed control input (input voltage: 0...5 / 0...10 V DC)
D	Reinforced flange corners with through-holes (Series 44xx F) Constant speed control independent from operating voltage
E	Economy fan with round flange
F	Flat construction / frequency-modulated signal
G	Sleeve bearing
H	High speed
<b>HH</b>	<b>Further increased speed</b>
H3-H8	Additional further increased speeds (H8 - maximum fan speed)
I	Integrated temperature sensor (NTC behaviour, i.e. thermistor)
J	Jet characteristic / rigid curve
L	Low speed
M	Medium speed
ML	Between low and medium speed
N	Standard or basic speed (only DC fans)
O	Multi-option speed control input (analogue or PWM signal)
P	PWM speed control input (pulse-width modulated signal)
R	Moisture protection coating
S	Circuit board and winding (IP 20), optional stainless steel ball bearing
T	Speed signal (additional wires for hall signal, obsolete technology)
TD	External temperature sensor (NTC behaviour, i.e. thermistor)
U	Turbo drive (extremely powerful 3-phase motor)
V / VP	Environmentally friendly fan (min. IP 54)
W	VARIOFAN
X	Additional wires (standard length 310 mm)
-xxx	Mounting bore hole 3.7 mm
	Variant number

## AC axial fan e.g. 3950 L

Housing dimensions (W x H x D)			Operating voltage			Options (various versions possible)			
Value	Edge dimensions (W x H)	Installation depth (D)	Value	Nominal voltage	Frequency	Design			
<b>3</b>	<b>92 x 92 mm</b>	<b>25 / 38 mm</b>	0	115 V	60 Hz	Speed signal			
4	119 x 119 mm	25 / 32 / 38 mm	2	115 V	60 Hz	1 Impulses per 360 degrees (additional magnet sensor and hall sensor)			
5	127 x 127 mm	38 mm	3	115 V	60 Hz	Low speed			
5	135 x 135 mm	38 mm	4	115 V	50 Hz	Medium speed			
5	140 x 140 mm	51 mm	<b>5</b>	<b>230 V</b>	<b>50 Hz</b>	Air intake via struts (Ø mounting bore hole)			
6	Ø 172 mm	51 / 52 mm	6	115 V / 230 V	50 Hz / 60 Hz	Moisture protection coating			
7	Ø 150 mm	55 mm	7	230 V	50 Hz	Circuit board and winding (IP 20), optional stainless steel ball bearing			
7	Ø 150 x 172 mm	38 mm	8	230 V	60 Hz	Integrated temperature switch			
8	80 x 80 mm	38 mm	9	230 V	60 Hz	Assembly bracket			
9	119 x 119 mm	25 mm						U	Environmentally friendly fan (min. IP 54)

Motor and housing version		Bearing type and insulation class	
Value	Version	Value	Insulation class
4	Shaded-pole motor, 55 mm (D) medium speed	0	Sleeve bearing E
5	Shaded-pole motor, 38 mm (D) medium / high speed	5	Ball bearing E
6	Shaded-pole motor, 38 mm (D) high speed	6	Ball bearing F
7	Shaded-pole motor, 38 mm (D) with assembly bracket	8	Ball bearing E
8	Shaded-pole motor, slow / medium speed		
<b>9</b>	<b>Shaded-pole motor, 25 / 38 mm (D)</b>		

Options (various versions possible)	
V	Air exhaust via struts
W	Additional wires (standard length 310 mm)
X	Mounting bore hole 3.7 mm
-xxx	Variant number
Z	Air exhaust via struts, reinforced flange corners with through-holes

All dimensions in millimetres [mm].

# Type code

## AC centrifugal fan e.g. RER 160-28/56 S

Type	Housing and fan impeller versions
RE	Housing Impeller blade design None Non-curved, no direction of rotation set
REF	None Forwards/backwards-curved impeller blades, flat
<b>RER</b>	<b>None Backwards-curved impeller blades</b>
RET	None Forwards-curved impeller blades
RG	Square Forwards/backwards-curved impeller blades
RL	Round Forwards-curved impeller blades
RLF	Round Forwards/backwards-curved impeller blades, flat
RV	Round Forwards-curved impeller blades

Options (various versions possible)	
A	Intake via bars
E	Made by ebm-papst Mulfingen (6xxx, 7xxx range) or round flange
H	Speed signal 1 Impulses per 360 degrees (additional magnet sensor and hall sensor)
L	Low speed
M	Medium speed
N	Fan intake via bars (Ø mounting bore hole)
R	Moisture protection coating Circuit board and winding (IP 20), optional stainless steel ball bearing
<b>S</b>	<b>Integrated temperature switch</b>
T	Assembly bracket
U	Environmentally friendly fan (min. IP 54)
V	Air exhaust via bars
W	Additional wires (standard length 310 mm)
X	Mounting bore hole 3.7 mm
-xxx	Variant number
Z	Air exhaust via bars, reinforced flange joints with through-holes

Height fan impeller blade

R E R      1 6 0 - 2 8 / 5 6      S

Diameter fan impeller

Operating voltage		
Value	Nominal voltage	Frequency
/00	115 V	60 Hz
/06	115 V	60 Hz
/50	230 V	50 Hz
<b>/56</b>	<b>230 V</b>	<b>50 Hz</b>

## DC centrifugal fan e.g. R2E 190-A026-05

Note: This type code specifies fans from ebm-papst Mulfingen and can be used to clearly identify and order them:

Type	Housing and fan impeller versions
A	Axial fan
S	Axial fan with safety grille
W	Axial fan with wall ring
V	Axial combination
<b>R</b>	<b>Centrifugal fan, one-sided intake</b>
G	Centrifugal blower, one-sided intake (with scroll housing)
B	Centrifugal fan, double-sided intake
G	Centrifugal blower, double-sided intake (with scroll housing)
K	Centrifugal combination

Diameter fan impeller

Mechanical design code

Mechanical variants code

R 2 E      1 9 0 - A 0 2 6      - 0 5

Number of poles (AC)	2 <b>2-pole</b>
Number of cores (DC/EC)	1    1-phase/core 3    3-phase/core

Motor type	
D	Three-phase motor
<b>E</b>	<b>One-phase motor with operating capacitor</b>
G	DC/EC motor

Electrical design code

All dimensions in millimetres [mm].





Quiet but powerful.



Our new compact fan in the 420J range is a particularly quiet and energy-efficient DC fan. Compared to its predecessors it uses 70% less power and is up to 5 dB(A) quieter, and it nonetheless achieves an airflow of 38 m<sup>3</sup>/h and a pressure build-up of up to 175 Pa in the saddle area – all squeezed in to just 40 x 40 x 28 mm. It works efficiently even in harsh environmental conditions. The ideal choice for IT servers, routers or compact frequency converters and welding inverters. For more information, visit: [www.ebmpapst.com](http://www.ebmpapst.com)

**ebmpapst**

The engineer's choice



# DC axial fans



DC axial fan overview

27

DC axial fans / DC diagonal fans

31

# DC axial fans

## Technical information



### Range of fans

ebm-papst offers you the widest full product line of DC axial and diagonal fans: From 25 mm to 280 mm in size. Every single type of fan can be optimally integrated in the respective device concept. The highly economical brushless motor technology of these fans provides a unique variety of intelligent innovations that can be realised today at prices that would have been unthinkable just a few years ago.

### Electronic protection against reverse polarity

ebm-papst DC fans have electronically commutated drives with electronic protection against reverse polarity. The electronics are conveniently located in the fan hub.

### Product life expectancy

A distinctive feature of DC fan technology is the convincingly high product life expectancy. Thanks to the excellent efficiency of the brushless drives, the thermal load of the bearings is reduced, thus considerably increasing the life expectancy of the fans.

### Type of protection

DC fans with sleeve and ball bearings are powered by class E insulated motors. All ebm-papst fans conform to the requirements of type of protection IP 20. Fans conforming to IP 54 / IP 68 and special types of protection are also available.

### Voltage range

Many of our DC fans can be operated on voltages that are up to 50% lower and 25% higher than their nominal voltage (see Voltage range in the technical tables). This enables the air performance to be adapted to the cooling requirements and allows the noise to be reduced, even if the fan does not have a control input.

### Closed-loop speed control and monitoring

Closed-loop speed control and function monitoring are becoming increasingly important in many applications. ebm-papst offers many fans in the standard design with a control input and open collector speed signal.

### S-Force

The new S-Force fans with their extremely high blower capacity of up to 950 m<sup>3</sup>/h and pressure build-up of up to 1200 pascals are capable of dealing with the extreme heat load. If needed, these fans can produce up to 100% more output under full load and they work with a much broader delivery bandwidth than current models. This makes them ideal for equipment and systems with a high density of components. Thanks to intelligent motor features, they can be individually adapted for any application. S-Force fans are available in 5 standard dimensions.

### S-Panther

S-Panther power delivered quietly. Wherever there is need for power and reduced noise, fans from the S-Panther range are the right solution. A strong pressure saddle curve at optimum air flow provides the power of a real big cat.

# Axial fans for DC operation

## Overview of air performance

Dimensions	Series	Air flow	Air flow (m³/h)																			Page		
			10	20	30	40	50	60	70	80	90	100	200	300	400	500	600	700	800	900	1000		2000	3000
<input type="checkbox"/> 25 x 8	250	2,3...4,6																						31
<input type="checkbox"/> 40 x 10	400 F	6...9																						32
<input type="checkbox"/> 40 x 20	400	10...13,5																						33
<input type="checkbox"/> 40 x 28	420 J	24...38	NEW																					34
<input type="checkbox"/> 50 x 15	500 F	11...20																						35
<input type="checkbox"/> 60 x 15	600 F	19...33																						36
<input type="checkbox"/> 60 x 25	620	21...67																						37
<input type="checkbox"/> 60 x 25	630	40...44																						38
<input type="checkbox"/> 60 x 25	600 N	21...56																						39
<input type="checkbox"/> 60 x 25	600 N VARIOFAN	16...41																						40
<input type="checkbox"/> 60 x 32	600 J	70...82																						41
<input type="checkbox"/> 70 x 15	700 F	28...44																						42
<input type="checkbox"/> 80 x 25	8450	32...117																						43
<input type="checkbox"/> 80 x 25	8400 N	33...79																						44
<input type="checkbox"/> 80 x 25	8400 N VARIOFAN	20...58																						45
<input type="checkbox"/> 80 x 32	8300	32...80																						46
<input type="checkbox"/> 80 x 38	8200 J	132...222																						47
<input type="checkbox"/> 92 x 25	3400 N	61...102																						48
<input type="checkbox"/> 92 x 25	3400 N VARIOFAN	44...84																						49
<input type="checkbox"/> 92 x 32	3300	56...107																						50
<input type="checkbox"/> 92 x 32	3300 N	56...133	NEW																					51
<input type="checkbox"/> 92 x 38	3200 J	130...280																						52
<input type="checkbox"/> 92 x 38	3250 J	145...270	NEW																					53
<input type="checkbox"/> 119 x 25	4400 F	94...170																						54
<input type="checkbox"/> 119 x 25	4400 FN	200...225																						55
<input type="checkbox"/> 119 x 32	4300	95...204																						56
<input type="checkbox"/> 119 x 32	4300 VARIOFAN	65...170																						57

Subject to alternations



# Axial fans for DC operation

## Overview of air performance

Dimensions	Series	Air flow	Air flow (m³/h)													Page												
			10	20	30	40	50	60	70	80	90	100	200	300	400		500	600	700	800	900	1000	2000	3000				
mm		m³/h																										
□ 119 x 38	4400	100...285																										58/59
□ 119 x 38	4100 N	160...237																										60
□ 119 x 38	4100 NHH..NH6	260...440																										61
□ 119 x 38	4100 NH7..NH8	500...570																										62
□ 119 x 38	DV 4100	280																										63
□ 127 x 38	5200 N	187...340																										64
□ 127 x 38	DV 5200	270...320																										65
□ 135 x 38	5100 N	260																										66
□ 140 x 51	5300	340																										67
□ 140 x 51	5300 TD	410...670																										68
∅ 150 x 38	7100 N	308...360																										69
∅ 150 x 55	7200 N	360																										70
172x160x52	6100 N	350																										71
∅ 172 x 51	6300	395...545																										72
∅ 172 x 51	6300 TD	600...930																										73
172x160x51	6300 TD	710...930																										74
∅ 172 x 51	DV 6300	630...1100	NEW																									75
172x150x51	6400	350...480																										76
172x150x51	6400 TD Turbofan	90...900																										77
172x160x51	DV 6400	530																										78
172x160x51	DV 6400 TD Turbofan	100...680																										79
220x200x51	2200 FTD	790...1220																										80
□ 225 x 80	2200 TD	1000																										81
□ 225 x 80	K1G 200	1020...1245																										82
□ 225 x 89	K3G 200	725...905																										83
∅ 250	W1G 250	2070																										84
∅ 300	*1G 300	2320...2345																										86

Subject to alternations





# Axial fans for DC operation

## Overview of technically feasible designs

Axial fans		Dimensions	VDE, UL, CSA	Sinter sleeve bearings/ball bearings	Speed signal	Go / No-go alarm	Alarm with limit speed	External temperature sensor	Internal temperature sensor	PWM control input	Analogue control input	Multi-option control input	Humidity protection	IP >= IP 54	IP >= IP 68	Salt fog protection	Reversible direction of rotation	Page
Series	mm																	
										OPTIONAL								p.
250	25 x 25 x 8	ja	□	•	-	-	-	-	-	-	-	-	•	-	-	-	-	31
400 F	40 x 40 x 10	ja	□	•	•	-	-	-	-	-	-	-	•	-	-	-	-	32
400	40 x 40 x 20	ja	□	•	•	-	-	-	•	-	-	-	•	-	-	-	-	33
NEW 420 J	40 x 40 x 28	ja	■	•	•	-	•	-	•	-	-	-	•	-	-	•	-	34
500 F	50 x 50 x 15	ja	□	•	•	-	-	-	•	-	-	-	•	-	-	-	-	35
600 F	60 x 60 x 15	ja	□	•	•	-	-	-	•	-	-	-	•	-	-	-	-	36
620	60 x 60 x 25	ja	■	•	•	•	•	•	•	•	-	-	•	-	-	-	-	37
630	60 x 60 x 25	ja	■	•	•	•	•	-	•	•	-	-	•	•	•	•	-	38
600 N	60 x 60 x 25	ja	□/■	•	•	-	-	-	-	-	-	-	•	•	•	-	-	39
600 N VARIOFAN	60 x 60 x 25	ja	□/■	•	•	-	•	•	-	-	-	-	•	-	-	-	-	40
600 J	60 x 60 x 32	ja	■	•	•	-	•	-	•	•	-	-	•	-	-	-	-	41
700 F	70 x 70 x 15	ja	□	•	•	-	-	-	-	-	-	-	•	-	-	-	-	42
8450	80 x 80 x 25	ja	□/■	•	•	•	•	•	•	•	-	-	•	-	-	-	-	43
8400 N	80 x 80 x 25	ja	□/■	•	•	•	•	•	•	•	-	-	•	•	•	-	-	44
8400 N VARIOFAN	80 x 80 x 25	ja	□	•	•	-	•	•	-	-	-	-	•	-	-	-	-	45
8300	80 x 80 x 32	ja	■	•	•	•	•	•	•	•	-	-	•	•	•	•	-	46
<i>S-Face</i> 8200 J	80 x 80 x 38	ja	■	•	•	•	•	•	•	•	-	-	•	•	-	-	-	47
3400 N	92 x 92 x 25	ja	□/■	•	•	•	•	•	•	•	-	-	•	•	•	-	-	48
3400 N VARIOFAN	92 x 92 x 25	ja	□	•	•	-	•	•	-	-	-	-	•	-	-	-	-	49
3300	92 x 92 x 32	ja	□/■	•	•	•	•	•	•	•	-	-	•	•	•	•	-	50
NEW 3300 N	92 x 92 x 38	ja	■	•	•	-	•	•	•	•	-	-	•	•	-	•	-	51
<i>S-Face</i> 3200 J	92 x 92 x 38	ja	■	•	•	•	•	•	•	•	-	-	•	•	•	-	-	52
NEW <i>S-Panther</i> 3250 J	92 x 92 x 38	ja	■	•	•	-	•	•	•	•	-	-	•	•	-	•	-	53
4400 F	119 x 119 x 25	ja	□/■	•	•	•	•	•	•	•	-	-	•	-	-	-	-	54
4400 FN	119 x 119 x 25	ja	■	•	•	•	•	•	•	•	-	-	•	-	-	-	-	55
4300	119 x 119 x 32	ja	□/■	•	•	•	•	•	•	•	-	-	•	•	•	•	-	56
4300 VARIOFAN	119 x 119 x 32	ja	■	•	•	•	•	•	•	•	-	-	•	-	-	-	-	57

\* approvals-applied for    □ not yet available    □ Sleeve bearings  
 • available                    ■ Ball bearings

Please note that these special versions are not possible for all voltages and speeds, and not in all combinations.

The special versions are designed for specific customers and projects. As a rule they are not available off the shelf and are tied to minimum volumes.

Please consult your customer support representative about the feasibility of your special variant.

# Axial fans for DC operation

## Overview of technically feasible designs

Axial fans		Dimensions	VDE, UL, CSA	Sinter sleeve bearings	ball bearings	Speed signal	Go / No-go alarm	Alarm with limit speed	External temperature sensor	Internal temperature sensor	PWM control input	Analogue control input	Multi-option control input	Humidity protection	IP >= IP 54	IP >= IP 68	Salt fog protection	Reversible direction of rotation	Page
Series	mm																		p.
4400	119 x 119 x 38	ja	■	•	•	•	•	•	•	•	•	•	•	•	•	•	•	•	58/59
4100 N	119 x 119 x 38	ja	□/■	•	•	•	•	•	•	•	•	•	•	•	•	•	•	•	60
<i>S-Force</i> 4100 NH..NH6	119 x 119 x 38	ja	■	•	•	•	•	•	•	•	•	•	•	•	•	•	•	•	61
<i>S-Force</i> 4100 NH7..NH8	119 x 119 x 38	ja	■	•	•	•	•	•	•	•	•	•	•	•	•	•	•	•	62
DV 4100	119 x 119 x 38	ja	■	•	•	•	•	•	•	•	•	•	•	•	•	•	•	•	63
5200 N	127 x 127 x 38	ja	■	•	•	•	•	•	•	•	•	•	•	•	•	•	•	•	64
DV 5200	127 x 127 x 38	ja	■	•	•	•	•	•	•	•	•	•	•	•	•	•	•	•	65
5100 N	135 x 135 x 38	ja	■	•	•	•	•	•	•	•	•	•	•	•	•	•	•	•	66
<i>S-Force</i> 5300	140 x 140 x 51	ja	■	•	•	•	•	•	•	•	•	•	•	•	•	•	•	•	67
<i>S-Force</i> 5300 TD	140 x 140 x 51	ja	■	•	•	•	•	•	•	•	•	•	•	•	•	•	•	•	68
7100 N	Ø 150 x 38	ja	■	•	•	•	•	•	•	•	•	•	•	•	•	•	•	•	69
7200 N	Ø 150 x 55	ja	■	•	•	•	•	•	•	•	•	•	•	•	•	•	•	•	70
6100 N	172 x 160 x 51	ja	■	•	•	•	•	•	•	•	•	•	•	•	•	•	•	•	71
<i>S-Force</i> 6300	Ø 172 x 51	ja	■	•	•	•	•	•	•	•	•	•	•	•	•	•	•	•	72
<i>S-Force</i> 6300 TD	Ø 172 x 51	ja	■	•	•	•	•	•	•	•	•	•	•	•	•	•	•	•	73
<i>S-Force</i> 6300 TD	172 x 160 x 51	ja	■	•	•	•	•	•	•	•	•	•	•	•	•	•	•	•	74
NEW DV 6300	172 x 160 x 51	ja	■	•	•	•	•	•	•	•	•	•	•	•	•	•	•	•	75
6400	172 x 150 x 51	ja	■	•	•	•	•	•	•	•	•	•	•	•	•	•	•	•	76
6400 TD <i>Turbofan</i>	172 x 150 x 51	ja	■	•	•	•	•	•	•	•	•	•	•	•	•	•	•	•	77
DV 6400	172 x 160 x 51	ja	■	•	•	•	•	•	•	•	•	•	•	•	•	•	•	•	78
DV 6400 TD	172 x 160 x 51	ja	■	•	•	•	•	•	•	•	•	•	•	•	•	•	•	•	79
2200 FTD	Ø 200 x 51	ja	■	•	•	•	•	•	•	•	•	•	•	•	•	•	•	•	80
<i>S-Force</i> NEW 2200 TD	225 x 225 x 80	ja	■	•	•	•	•	•	•	•	•	•	•	•	•	•	•	•	81
K1G 200	225 x 225 x 80	ja	■	•	•	•	•	•	•	•	•	•	•	•	•	•	•	•	82
K3G 200	225 x 225 x 89	ja	■	•	•	•	•	•	•	•	•	•	•	•	•	•	•	•	83

Subject to alternations

\* approvals-applied for    □ not yet available    □ Sleeve bearings  
 • available                    ■ Ball bearings

Please note that these special versions are not possible for all voltages and speeds, and not in all combinations.

The special versions are designed for specific customers and projects. As a rule they are not available off the shelf and are tied to minimum volumes.

Please consult your customer support representative about the feasibility of your special variant.

max. 4,6 m<sup>3</sup>/h

# DC axial fans

Series 250 25 x 25 x 8 mm



- **Material:** Housing: GRP<sup>1)</sup> (PBT)  
Impeller: GRP<sup>1)</sup> (PA)
  - **Direction of air flow:** Exhaust over struts
  - **Direction of rotation:** Counter-clockwise, seen on rotor
  - **Connection:** Via single wires AWG 28, TR 64
  - **Mass:** 5 g
- **Possible special versions:**  
(See chapter DC fans - specials)
    - Speed signal
    - Protection against moisture

1) Fibreglass-reinforced plastic

Nominal data	Air flow		Nominal voltage	Voltage range	Sound pressure level	Sound power level	Sinter sleeve bearings Ball bearings	Input power	Nominal speed	Temperature range	Service life L <sub>10</sub> (20 °C) ebm-papst Standard	Service life L <sub>10</sub> (60 °C) ebm-papst Standard	Life expectancy L <sub>10</sub> IPC (40 °C) see page 17	Curve
	m <sup>3</sup> /h	CFM												
255 M	2,3	1,2	5	4,5...5,5	5	< 3	■	0,2	6 500	-10...+70	45 000 / 17 500	47 500	①	
255 N	3,5	1,9	5	4,5...5,5	16	< 3	■	0,4	9 600	-10...+70	40 000 / 15 000	42 500	②	
255 H	4,6	2,6	5	4,5...5,5	23	4,4	■	0,6	12 000	-10...+55	35 000 / 15 000*	37 500	③	
252 N	3,4	1,9	12	10...14	15	< 3	■	0,5	9 000	-10...+70	40 000 / 15 000	42 500	②	
252 H	4,6	2,6	12	10...14	23	4,4	■	0,7	12 000	-10...+55	35 000 / 15 000*	37 500	③	

Subject to alternations

\* at 55 °C

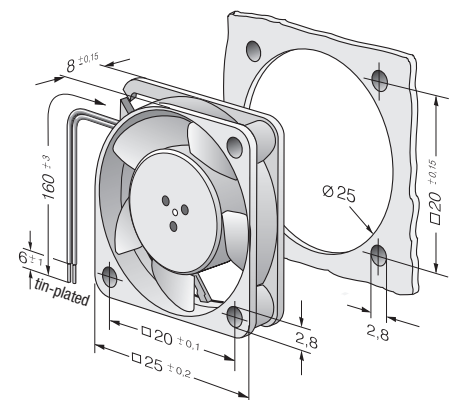
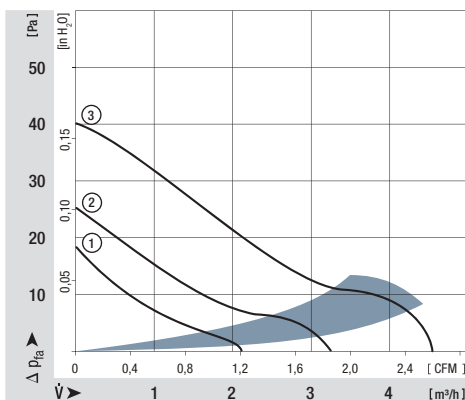

max. 9 m<sup>3</sup>/h

# DC axial fans

Series 400 F 40 x 40 x 10 mm



- **Material:** Housing: GRP<sup>1)</sup> (PBT)  
Impeller: GRP<sup>1)</sup> (PA)
  - **Direction of air flow:** Exhaust over struts
  - **Direction of rotation:** Counter-clockwise, seen on rotor
  - **Connection:** Via single wires AWG 28, TR 64
  - **Highlights:** Some models are suitable for use at high ambient temperatures
  - **Mass:** 17 g
- **Possible special versions:**  
(See chapter DC fans - specials)
    - Speed signal
    - Go / No-go alarm
    - Protection against moisture

1) Fibreglass-reinforced plastic

Nominal data	Air flow		Nominal voltage	Voltage range	Sound pressure level	Sound power level	Sinter sleeve bearings Ball bearings	Input power	Nominal speed	Temperature range	Service life L <sub>10</sub> (20 °C) ebm-papst Standard	Service life L <sub>10</sub> (60 °C) ebm-papst Standard	Life expectancy L <sub>10</sub> IPC (40 °C) see page 17	Curve
	m <sup>3</sup> /h	CFM												
405 F	8	4,7	5	4,5...5,5	22,1	4,4	□	0,7	5 400	-20...+70	45 000 / 17 500	47 500	②	
405 FH	9	5,3	5	4,5...5,5	26,0	4,6	□	0,9	6 000	-20...+70	45 000 / 17 500	47 500	③	
412 FM	6	3,5	12	10...14	17,0	3,8	□	0,5	4 300	-20...+70	45 000 / 17 500	47 500	①	
412 F	8	4,7	12	10...14	22,1	4,4	□	0,7	5 400	-20...+70	45 000 / 17 500	47 500	②	
412 FH	9	5,3	12	10...14	26,0	4,6	□	0,8	6 000	-20...+70	45 000 / 17 500	47 500	③	
414 F	8	4,7	24	20...28	22,1	4,4	□	0,8	5 400	-20...+70	45 000 / 17 500	47 500	②	
414 FH	9	5,3	24	21,6...26,4	26,0	4,4	□	0,9	6 000	-20...+70	45 000 / 17 500	47 500	③	
Model with temperature range up to +85 °C.														
412 FM-074	6	3,5	12	10...14	17,0	3,8	□	0,4	4 300	-20...+85	45 000 / 17 500	47 500	①	
412 F-130	8	4,7	12	10...14	22,1	4,4	□	0,6	5 400	-20...+85	45 000 / 17 500	47 500	②	
412 FH-132	9	5,3	12	10...14	26,0	4,6	□	0,8	6 000	-20...+85	45 000 / 17 500	47 500	③	

Subject to alternations

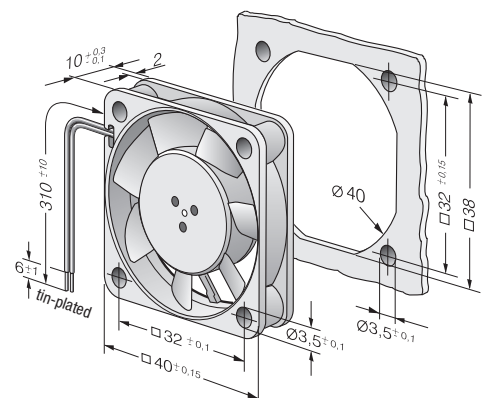
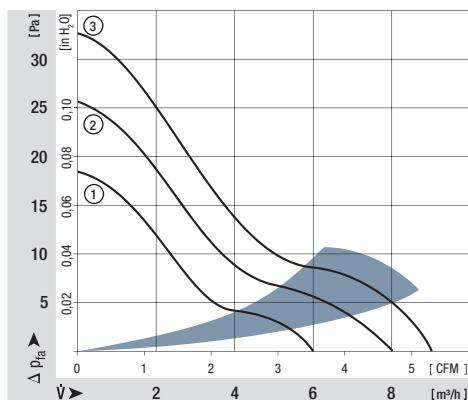

max. 13,5 m<sup>3</sup>/h

# DC axial fans

Series 400 40 x 40 x 20 mm



- **Material:** Housing: GRP<sup>1)</sup> (PBT)  
Impeller: GRP<sup>1)</sup> (PA)
  - **Direction of air flow:** Exhaust over struts
  - **Direction of rotation:** Counter-clockwise, seen on rotor
  - **Connection:** Via single wires AWG 28, TR 64
  - **Highlights:** Some models are suitable for use at high ambient temperatures
  - **Mass:** 27 g
- **Possible special versions:**  
(See chapter DC fans - specials)
    - Speed signal
    - Go / No-go alarm
    - PWM control input
    - Protection against moisture

1) Fibreglass-reinforced plastic

Nominal data	Air flow	Air flow	Nominal voltage	Voltage range	Sound pressure level	Sound power level	Sinter sleeve bearings Ball bearings	Input power	Nominal speed	Temperature range	Service life L <sub>10</sub> (20 °C) ebm-papst Standard	Service life L <sub>10</sub> (60 °C) ebm-papst Standard	Life expectancy L <sub>10</sub> IPC (40 °C) see page 17	Curve
Type	m <sup>3</sup> /h	CFM	VDC	VDC	dB(A)	Bel(A)	□ / ■	Watts	rpm	°C	Hours	Hours	Hours	①
405	10,0	5,9	5	4,5...5,5	18	3,8	□	0,9	6 000	-20...+70	50 000 / 20 000	52 500	52 500	①
412	10,0	5,9	12	10...14	18	3,8	□	0,8	6 000	-20...+70	50 000 / 20 000	52 500	52 500	①
412 H	13,5	7,9	12	10...14	29	4,7	□	1,6	8 100	-20...+60	45 000 / 17 500	47 500	47 500	②
414	10,0	5,9	24	20...28	18	3,8	□	1,0	6 000	-20...+70	50 000 / 20 000	52 500	52 500	①
414 H	13,5	7,9	24	20...26,5	29	4,7	□	1,7	8 100	-20...+60	45 000 / 17 500	47 500	47 500	②
Model with temperature range up to +85 °C.														
412-099	10,0	5,9	12	10...14	18	3,8	□	0,8	6 000	-20...+85	50 000 / 20 000	52 500	52 500	①
Subject to alternations														

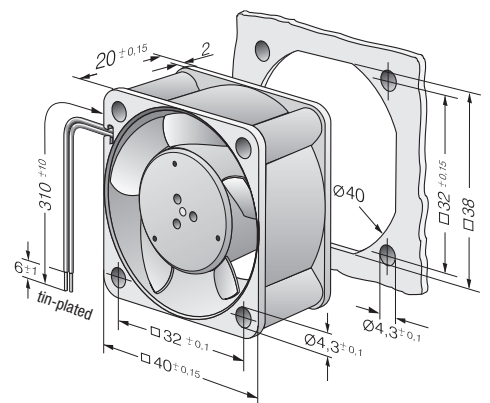
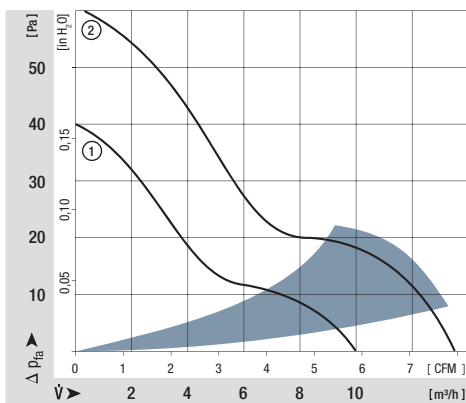

max. 38 m<sup>3</sup>/h

# DC axial fans

Series 420 J 40 x 40 x 28 mm



- **Material:** Housing: GRP<sup>1)</sup> (PBT)  
Impeller: GRP<sup>1)</sup> (PA)
  - **Direction of air flow:** Exhaust over struts
  - **Direction of rotation:** Counter-clockwise, seen on rotor
  - **Connection:** Via single wires AWG 28, UL 1061
  - **Mass:** 45 g
- **Possible special versions:**  
(See chapter DC fans - specials)
    - Speed signal
    - Go / No-go alarm
    - External temperature sensor
    - PWM control input
    - Protection against moisture
    - Protection against salt fog

1) Fibreglass-reinforced plastic

Nominal data	Air flow		Nominal voltage	Voltage range	Sound pressure level	Sound power level	Sinter sleeve bearings Ball bearings	Input power	Nominal speed	Temperature range	Service life L <sub>10</sub> (20 °C) ebm-papst Standard	Service life L <sub>10</sub> (60 °C) ebm-papst Standard	Life expectancy L <sub>10</sub> IPC (40 °C) see page 17	Curve
	m <sup>3</sup> /h	CFM												
422 JM	24	14,2	12	8...13,8	42	5,5	■	2,5	11 100	-20...+70	75 000 / 37 500	127 500	①	
422 JN	31	18,3	12	8...13,8	48	6,0	■	4,0	14 000	-20...+70	67 500 / 35 000	115 000	②	
422 JH	38	22,4	12	8...13,8	54	6,6	■	6,8	17 200	-20...+70	60 000 / 30 000	102 500	③	
424 JM	24	14,2	24	16...28	42	5,5	■	2,7	11 100	-20...+70	75 000 / 37 500	127 500	①	
424 JN	31	18,3	24	16...28	48	6,0	■	4,2	14 000	-20...+70	67 500 / 35 000	115 000	②	
424 JH	38	22,4	24	16...26,4	54	6,6	■	7,1	17 200	-20...+65	60 000 / 32 500	102 500	③	

Subject to alternations

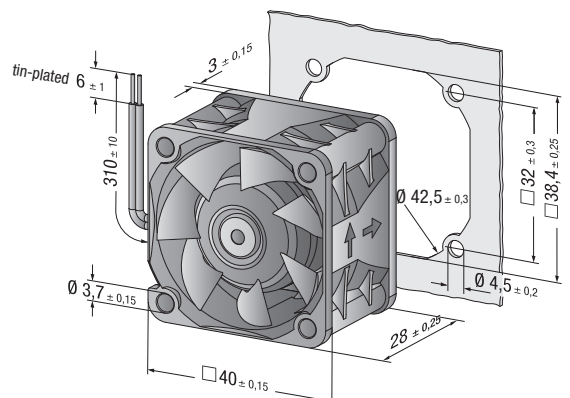
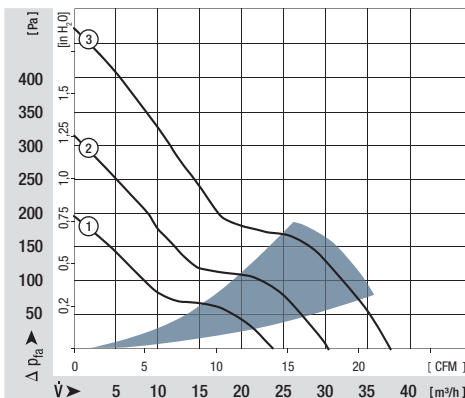



max. 20 m<sup>3</sup>/h

# DC axial fans

Series 500 F 50 x 50 x 15 mm



- **Material:** Housing: GRP<sup>1)</sup> (PBT)  
Impeller: GRP<sup>1)</sup> (PA)
  - **Direction of air flow:** Exhaust over struts
  - **Direction of rotation:** Counter-clockwise, seen on rotor
  - **Connection:** Via single wires AWG 28, TR 64
  - **Highlights:** Some models are suitable for use at high ambient temperatures
  - **Mass:** 27 g
- **Possible special versions:** (See chapter DC fans - specials)
    - Speed signal
    - Go / No-go alarm
    - PWM control input
    - Protection against moisture

1) Fibreglass-reinforced plastic

Nominal data	Air flow	Air flow	Nominal voltage	Voltage range	Sound pressure level	Sound power level	Sinter sleeve bearings Ball bearings	Input power	Nominal speed	Temperature range	Service life L <sub>10</sub> (20 °C) ebm-papst Standard	Service life L <sub>10</sub> (60 °C) ebm-papst Standard	Life expectancy L <sub>10</sub> (IPC (40 °C) see page 17	Curve
Type	m <sup>3</sup> /h	CFM	VDC	VDC	dB(A)	Bel(A)	□ / ■	Watts	rpm	°C	Hours	Hours	Hours	① / ②
512 F	20	11,8	12	10,8...13,2	30	4,5	□	0,8	5 000	-20...+70	50 000 / 20 000	52 500	52 500	②
514 F	20	11,8	24	21,6...26,4	30	4,5	□	0,9	5 000	-20...+70	50 000 / 20 000	52 500	52 500	②
Model with temperature range up to +85 °C.														
512 FL-547	11	6,5	12	10,2...13,8	18	3,7	□	0,4	3 000	-20...+85	50 000 / 20 000	52 500	52 500	①
512 F-532	20	11,8	12	10,8...13,2	30	4,5	□	0,9	5 000	-20...+85	50 000 / 20 000	52 500	52 500	②

Subject to alternations

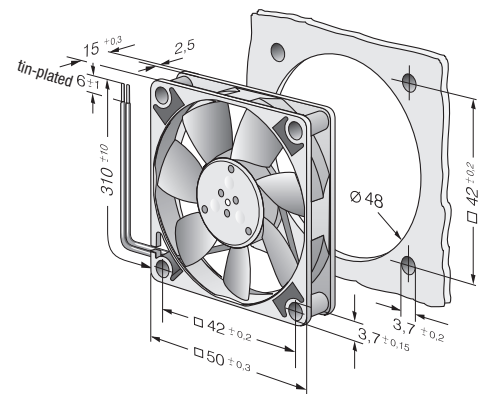
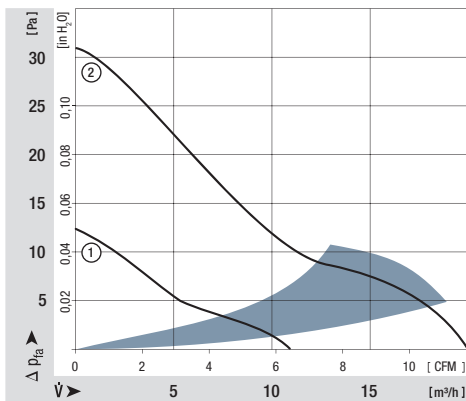

max. 33 m<sup>3</sup>/h

# DC axial fans

Series 600 F 60 x 60 x 15 mm



- **Material:** Housing: GRP<sup>1)</sup> (PBT)  
Impeller: GRP<sup>1)</sup> (PA)
  - **Direction of air flow:** Exhaust over struts
  - **Direction of rotation:** Counter-clockwise, seen on rotor
  - **Connection:** Via single wires AWG 28, TR 64
  - **Highlights:** Some models are suitable for use at high ambient temperatures
  - **Mass:** 30 g
- **Possible special versions:**  
(See chapter DC fans - specials)
    - Speed signal
    - Go / No-go alarm
    - PWM control input
    - Protection against moisture

1) Fibreglass-reinforced plastic

Nominal data	Air flow		Nominal voltage	Voltage range	Sound pressure level	Sound power level	Sinter sleeve bearings Ball bearings	Input power	Nominal speed	Temperature range	Service life L <sub>10</sub> (20 °C) ebm-papst Standard	Service life L <sub>10</sub> (60 °C) ebm-papst Standard	Life expectancy L <sub>10</sub> IPC (40 °C) see page 17	Curve
	m <sup>3</sup> /h	CFM												
605 F	29	17,1	5	4,5...5,2	27	4,4	□	1,1	4 000	-20...+50	50 000 / 20 000	52 500	52 500	②
612 FL	19	11,2	12	11,5...13,2	16	3,6	□	0,4	2 650	-20...+70	50 000 / 20 000	52 500	52 500	①
612 F	29	17,1	12	10,8...13,2	27	4,4	□	1,0	3 900	-20...+70	50 000 / 20 000	52 500	52 500	②
612 FH	33	19,4	12	10,0...13,2	31	4,8	□	1,5	4 500	-20...+60	45 000 / 17 500	47 500	47 500	③
614 F	29	17,1	24	21,6...26,4	27	4,4	□	1,1	3 900	-20...+70	50 000 / 20 000	52 500	52 500	②
614 F/39 H-691	33	19,4	24	16...28	31	4,8	□	1,4	4 500	-20...+60	45 000 / 17 500	47 500	47 500	③
Model with temperature range up to +80 / 85 °C.														
612 FL-680	19	11,2	12	11,5...14	16	3,6	□	0,5	2 650	-20...+85	50 000 / 20 000	52 500	52 500	①
612 F-637	29	17,1	12	10,8...12,6	27	4,4	□	1,0	3 900	-20...+80	50 000 / 20 000	52 500	52 500	②

Subject to alternations

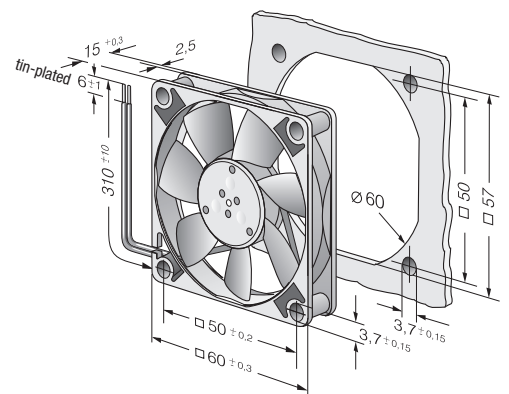
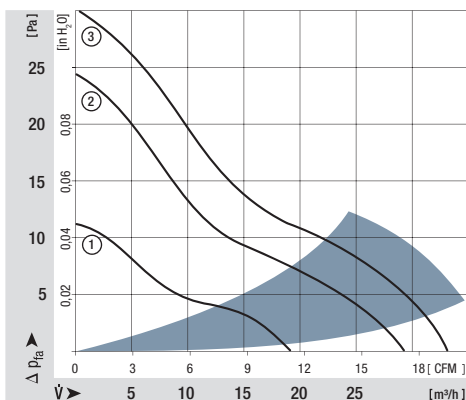

max. 67 m<sup>3</sup>/h

# DC axial fans

Series 620 60 x 60 x 25 mm



- **Material:** Housing: GRP<sup>1)</sup> (PBT)  
Impeller: GRP<sup>1)</sup> (PA)
  - **Direction of air flow:** Exhaust over struts
  - **Direction of rotation:** Clockwise, seen on rotor
  - **Connection:** Via single wires AWG 22, TR 64
  - **Highlights:** Very low-noise motor
  - **Mass:** 85 g
- **Possible special versions:**  
(See chapter DC fans - specials)
    - Speed signal
    - Go / No-go alarm
    - Alarm with limit speed
    - External temperature sensor
    - Internal temperature sensor
    - PWM control input
    - Analogue control input
    - Protection against moisture

1) Fibreglass-reinforced plastic

Nominal data	Air flow		Nominal voltage	Voltage range	Sound pressure level	Sound power level	Sinter sleeve bearings Ball bearings	Input power	Nominal speed	Temperature range	Service life L <sub>10</sub> (40 °C) ebm-papst Standard	Service life L <sub>10</sub> (T <sub>max</sub> ) ebm-papst Standard	Life expectancy L <sub>10</sub> (IPC (40 °C) see page 17	Curve
	m <sup>3</sup> /h	CFM												
622 L	21	12,4	12	8...15	20	3,7	■	0,5	3 200	-20...+85	80 000 / 20 000	135 000	①	
622 M	30	17,7	12	8...15	29	4,3	■	1,0	4 550	-20...+75	77 500 / 30 000	127 500	②	
622 N	40	23,5	12	8...15	35	4,7	■	1,9	6 100	-20...+70	72 500 / 35 000	117 500	③	
622 H	46	27,1	12	8...15	39	5,1	■	2,3	6 850	-20...+70	70 000 / 35 000	117 500	④	
622 HH	56	33,0	12	8...15	43	5,6	■	3,5	8 200	-20...+70	65 000 / 32 500	110 000	⑤	
622/2 H3P	67	39,4	12	8...13,2	48	5,9	■	8,0	9 700	-20...+60	52 500 / 32 500	87 500	⑥	
624 L	21	12,4	24	18...28	20	3,7	■	1,0	3 200	-20...+70	80 000 / 40 000	135 000	①	
624 M	30	17,7	24	12...28	29	4,3	■	1,5	4 550	-20...+70	77 500 / 37 500	130 000	②	
624 N	40	23,5	24	12...28	35	4,7	■	2,2	6 100	-20...+70	72 500 / 35 000	117 500	③	
624 H	46	27,1	24	18...28	39	5,1	■	2,4	6 850	-20...+70	70 000 / 35 000	117 500	④	
624 HH	56	33,0	24	18...28	43	5,6	■	3,6	8 200	-20...+70	65 000 / 32 500	110 000	⑤	
624/2 H3P	67	39,4	24	18...28	48	5,9	■	7,0	9 700	-20...+60	52 500 / 32 500	87 500	⑥	
628 HH	56	33,0	48	36...60	43	5,6	■	4,2	8 200	-20...+70	65 000 / 32 500	110 000	⑤	

Subject to alternations

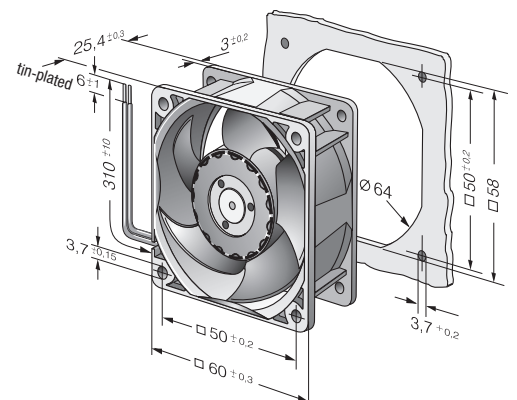
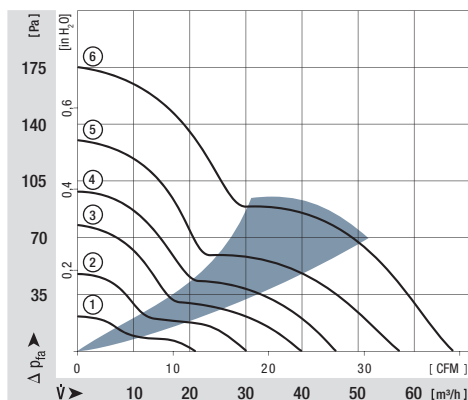

max. 44 m<sup>3</sup>/h

# DC axial fans

Series 630 60 x 60 x 25 mm



- **Material:** Housing: GRP<sup>1)</sup> (PBT)  
Impeller: GRP<sup>1)</sup> (PA)
  - **Direction of air flow:** Exhaust over struts
  - **Direction of rotation:** Clockwise, seen on rotor
  - **Connection:** Via single wires AWG 22, TR 64
  - **Highlights:** Developed for applications with demanding environmental requirements
  - **Mass:** 70 g
- **Possible special versions:**  
(See chapter DC fans - specials)
    - Speed signal
    - Go / No-go alarm
    - Alarm with limit speed
    - External temperature sensor
    - PWM control input
    - Analogue control input
    - Protection against moisture
    - Protection against salt fog
    - Type of protection: IP 54 / IP 68

1) Fibreglass-reinforced plastic

Nominal data	Air flow	Air flow	Nominal voltage	Voltage range	Sound pressure level	Sound power level	Sintec sleeve bearings Ball bearings	Input power	Nominal speed	Temperature range	Service life L <sub>10</sub> (40 °C) ebm-papst Standard	Service life L <sub>10</sub> (T <sub>max</sub> ) ebm-papst Standard	Life expectancy L <sub>10</sub> IPC (40 °C) see page 17	Curve
Type	m <sup>3</sup> /h	CFM	VDC	VDC	dB(A)	Bel(A)	□ / ■	Watts	rpm	°C	Hours	Hours	Hours	
632 NU	40	23,5	12	6...15	33	5,2	■	1,8	5 900	-20...+70	85 000 / 42 500	142 500	142 500	①
632/2 HPU	44	25,9	12	10,8...13,2	35	5,4	■	1,5	6 300	-20...+70	85 000 / 42 500	142 500	142 500	②
634 NU	40	23,5	24	12...30	34	5,1	■	1,6	5 900	-20...+70	85 000 / 42 500	142 500	142 500	①
638/2 HPU	44	25,9	48	40...60	35	5,4	■	1,8	6 300	-20...+70	85 000 / 42 500	142 500	142 500	②

Subject to alternations

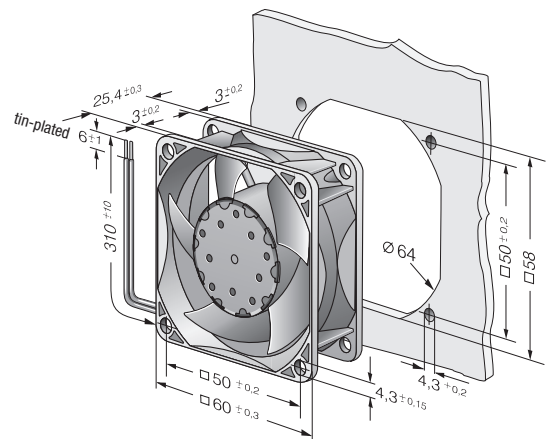
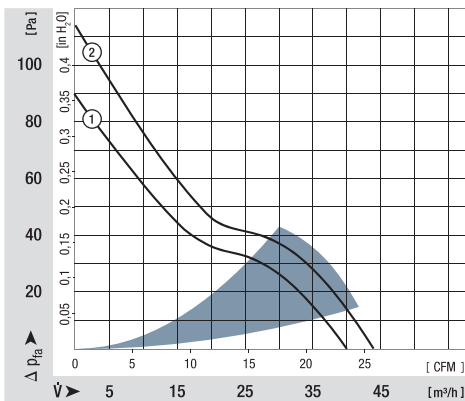

max. 56 m<sup>3</sup>/h

# DC axial fans

Series 600 N 60 x 60 x 25 mm



- **Material:** Housing: GRP<sup>1)</sup> (PBT)  
Impeller: GRP<sup>1)</sup> (PA)
- **Direction of air flow:** Exhaust over struts
- **Direction of rotation:** Clockwise, seen on rotor
- **Connection:** Via single wires AWG 22, TR 64
- **Highlights:** Some models are suitable for use at high ambient temperatures until 85 °C
- **Mass:** 66 g
- **Possible special versions:** (See chapter DC fans - specials)
  - Speed signal
  - Go / No-go alarm
  - Protection against moisture
  - Type of protection: IP 54 / IP 68

1) Fibreglass-reinforced plastic

Nominal data	Air flow		Nominal voltage	Voltage range	Sound pressure level	Sound power level	Sinter sleeve bearings Ball bearings	Input power	Nominal speed	Temperature range	Service life L <sub>10</sub> (40 °C) ebm-papst Standard	Service life L <sub>10</sub> (T <sub>max</sub> ) ebm-papst Standard	Life expectancy L <sub>10</sub> (IPC (40 °C) see page 17	Curve
	Type	m <sup>3</sup> /h												
612 NGLE	21	12,4	12	8...15	16	3,6	■	0,6	2 500	-20...+85	80 000 / 27 500	135 000	①	
612 NLE	21	12,4	12	8...15	16	3,6	■	0,4	2 500	-20...+85	80 000 / 27 500	135 000	①	
612 NGMLE	25	14,7	12	8...15	19	3,9	■	0,7	3 000	-20...+80	80 000 / 32 500	135 000	②	
612 NMLE	25	14,7	12	8...15	19	3,9	■	0,4	3 000	-20...+85	80 000 / 27 500	135 000	②	
612 NGME	35	20,6	12	8...15	28	4,6	■	1,2	4 100	-20...+75	80 000 / 35 000	135 000	③	
612 NME	35	20,6	12	8...15	28	4,6	■	0,8	4 100	-20...+75	80 000 / 35 000	135 000	③	
612 NN	42	24,7	12	8...15	35	5,0	■	1,5	5 100	-20...+70	70 000 / 35 000	117 500	④	
612 NH	43	25,3	12	8...15	37	5,3	■	1,8	5 600	-20...+70	70 000 / 35 000	117 500	⑤	
612 NHH-118	56	33,0	12	8...15	41	5,7	■	2,9	6 800	-20...+70	60 000 / 30 000	102 500	⑥	
614 NGL	21	12,4	24	18...28	16	3,6	■	1,0	2 500	-20...+70	80 000 / 40 000	135 000	①	
614 NL	21	12,4	24	18...28	16	3,6	■	0,8	2 500	-20...+70	80 000 / 40 000	135 000	①	
614 NGML	25	14,7	24	18...28	19	3,9	■	1,2	3 000	-20...+70	80 000 / 40 000	135 000	②	
614 NML	25	14,7	24	18...28	19	3,9	■	1,0	3 000	-20...+70	80 000 / 40 000	135 000	②	
614 NGM	35	20,6	24	18...28	28	4,6	■	1,7	4 100	-20...+70	80 000 / 40 000	135 000	③	
614 NM	35	20,6	24	18...28	28	4,6	■	1,3	4 100	-20...+70	80 000 / 40 000	135 000	③	
614 NN	42	24,7	24	18...28	35	5,0	■	1,8	5 100	-20...+70	70 000 / 35 000	117 500	④	
614 NH	43	25,3	24	18...26	37	5,3	■	2,1	5 600	-20...+70	70 000 / 35 000	117 500	⑤	
614 NHH	56	33,0	24	18...26	41	5,7	■	2,9	6 850	-20...+70	60 000 / 30 000	102 500	⑥	
614 NHH-119	56	33,0	24	18...28	41	5,7	■	2,9	6 850	-20...+70	60 000 / 30 000	102 500	⑥	
618 NM	35	20,6	48	36...56	28	4,6	■	1,9	4 100	-20...+70	80 000 / 40 000	135 000	③	
618 NN	42	24,7	48	36...56	35	5,0	■	2,1	5 100	-20...+65	70 000 / 40 000	117 500	④	

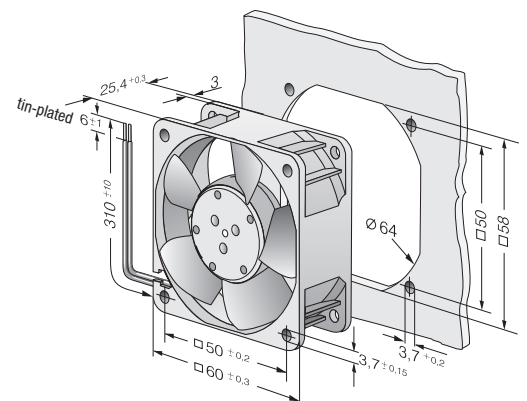
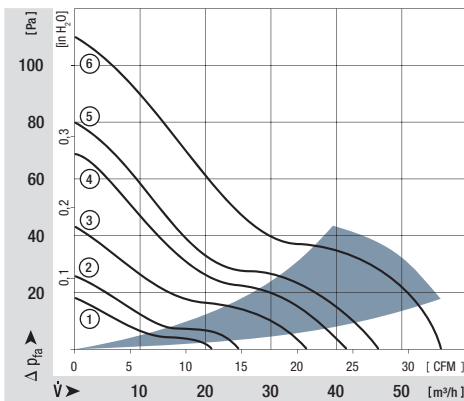

max. 41 m<sup>3</sup>/h

# DC axial fans

Series 600 N VARIOFAN 60 x 60 x 25 mm



- **Material:** Housing: GRP<sup>1)</sup> (PBT)  
Impeller: GRP<sup>1)</sup> (PA)
  - **Direction of air flow:** Exhaust over struts
  - **Direction of rotation:** Clockwise, seen on rotor
  - **Connection:** Via single wires AWG 22, TR 64
  - **Highlights:** Automatic speed adjustment with temperature sensor
  - **Mass:** 66 g
- **Possible special versions:** (See chapter DC fans - specials)
    - Speed signal
    - Go / No-go alarm
    - External temperature sensor
    - Internal temperature sensor
    - Protection against moisture

1) Fibreglass-reinforced plastic

Nominal data		Air flow	Air flow	Nominal voltage	Voltage range	Sound pressure level	Sound power level	Sintec sleeve bearings Ball bearings	Input power	Nominal speed	Temperature range	Service life L <sub>10</sub> (40 °C) ebm-papst Standard	Service life L <sub>10</sub> (T <sub>max</sub> ) ebm-papst Standard	Life expectancy L <sub>10</sub> IPC (40 °C) see page 17	Curve
Type		m <sup>3</sup> /h	CFM	VDC	VDC	dB(A)	Bel(A)	□ / ■	Watts	rpm	°C	Hours	Hours		
30°C 55°C	612 NGMI	18 35	10,6 20,6	12	8...12,6	14 28	3,5 4,6	□	1,3 1,7	2 150 4 100	-20...+65	80 000 / 45 000	135 000		① ②
30°C 55°C	612 NMI	16 35	9,4 20,6	12	8...12,6	16 28	3,6 4,6	■	1,0 1,4	2 400 4 100	-20...+65	80 000 / 45 000	135 000		③ ④
30°C 55°C	612 NGNI	23 41	13,5 24,1	12	8...12,6	18 35	3,8 5,0	□	1,7 2,4	2 900 5 100	-20...+65	70 000 / 40 000	117 500		⑤ ⑥
30°C 55°C	612 NNI	23 41	13,5 24,1	12	8...12,6	18 35	3,8 5,0	■	1,2 1,5	2 900 5 100	-20...+65	70 000 / 40 000	117 500		⑤ ⑥
30°C 55°C	612 NGNV	23 41	13,5 24,1	12	8...12,6	18 35	3,8 5,0	□	1,7 2,4	2 900 5 100	-20...+65	70 000 / 40 000	117 500		⑤ ⑥

Subject to alternations

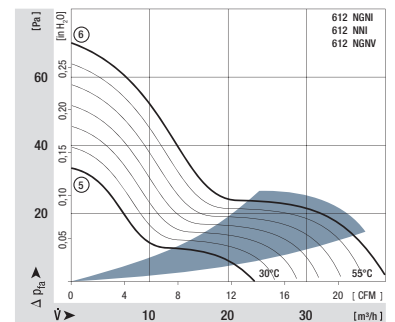
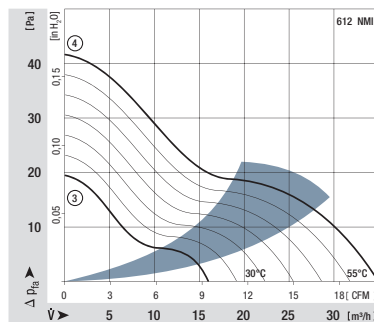
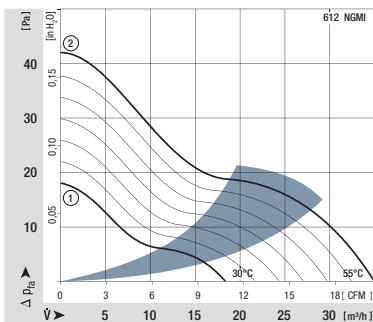

## V-Types

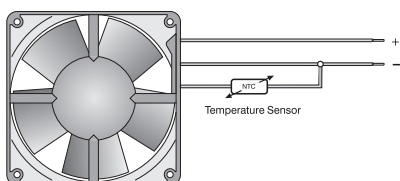

The temperature sensor for controlling the motor speed is not included in delivery.  
Temperature sensor LZ 370 see accessories.

## I-Types

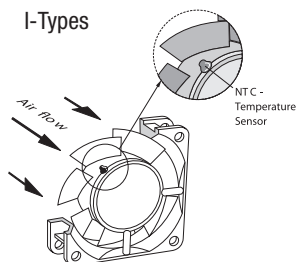

Temperature sensor (NTC-resistor) for controlling the motor speed is positioned directly in the air flow.

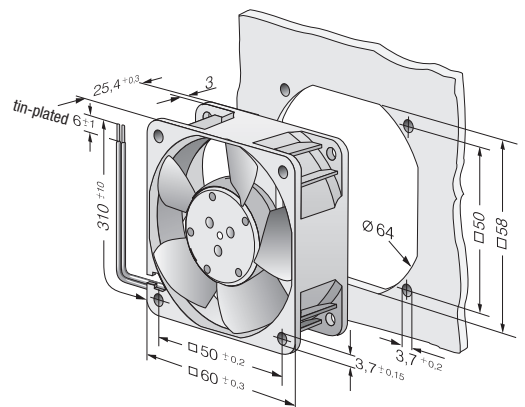



max. 82 m<sup>3</sup>/h

# DC axial fans

Series 600 J 60 x 60 x 32 mm



- **Material:** Housing: GRP<sup>1)</sup> (PBT)  
Impeller: GRP<sup>1)</sup> (PA)
  - **Direction of air flow:** Exhaust over struts
  - **Direction of rotation:** Clockwise, seen on rotor
  - **Connection:** Via single wires AWG 24, TR 64
  - **Mass:** 100 g
- **Possible special versions:**  
(See chapter DC fans - specials)
    - Speed signal
    - Go / No-go alarm
    - Alarm with limit speed
    - External temperature sensor
    - PWM control input
    - Analogue control input
    - Protection against moisture

1) Fibreglass-reinforced plastic

Nominal data	Air flow	Air flow	Nominal voltage	Voltage range	Sound pressure level	Sound power level	Sintec sleeve bearings Ball bearings	Input power	Nominal speed	Temperature range	Service life L <sub>10</sub> (40 °C) ebm-papst Standard	Service life L <sub>10</sub> (T <sub>max</sub> ) ebm-papst Standard	Life expectancy L <sub>10</sub> (IPC (40 °C) see page 17	Curve
Type	m <sup>3</sup> /h	CFM	VDC	VDC	dB(A)	Bel(A)	■ / ■	Watts	rpm	°C	Hours	Hours	Hours	①
612 JH	70	41,1	12	7...13,6	53	6,4	■	7,7	11 700	-20...+70	57 500 / 27 500	97 500	97 500	①
614 JH	70	41,1	24	14...26,4	53	6,4	■	7,7	11 700	-20...+70	57 500 / 27 500	97 500	97 500	①
618 JH	70	41,1	48	36...56	53	6,4	■	7,7	11 700	-20...+70	57 500 / 27 500	97 500	97 500	①
Fan types with streamer and integrated guard grille.														
614 J/2 HHP	82	48,3	24	18...30	62	7,6	■	14,6	15 000	-20...+75	65 000 / 25 000	110 000	110 000	②
618 J/2 HHP	82	48,3	48	38...58	62	7,6	■	14,6	15 000	-20...+75	65 000 / 25 000	110 000	110 000	②

Subject to alternations

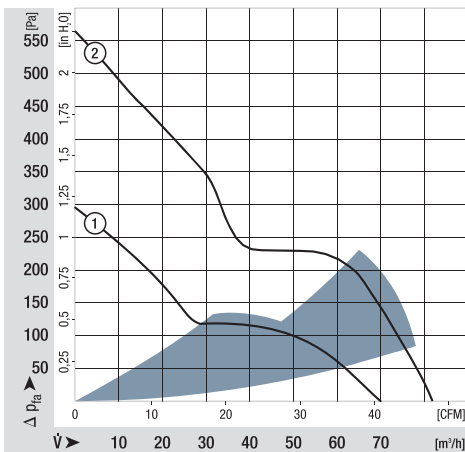

Rear view of types 614 J/2HHP and 618 J/2HHP

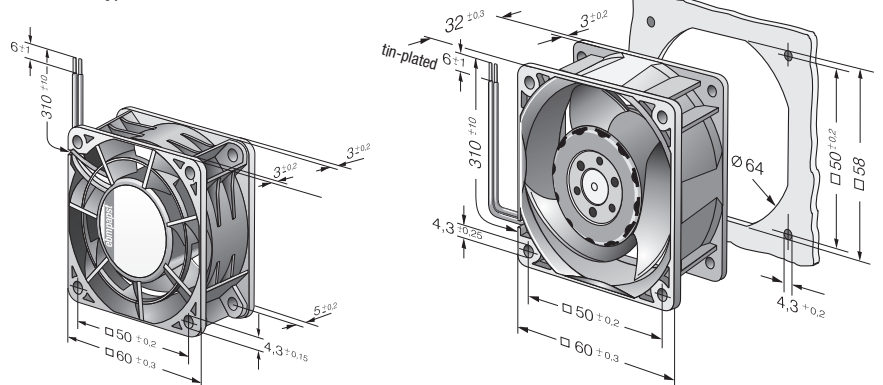

max. 44 m<sup>3</sup>/h

# DC axial fans

Series 700 F 70 x 70 x 15 mm



- **Material:** Housing: GRP<sup>1)</sup> (PBT)  
Impeller: GRP<sup>1)</sup> (PA)
  - **Direction of air flow:** Exhaust over struts
  - **Direction of rotation:** Counter-clockwise, seen on rotor
  - **Connection:** Via single wires AWG 24 to AWG 28, TR 64
  - **Mass:** 53 g
- **Possible special versions:**  
(See chapter DC fans - specials)
    - Speed signal
    - Go / No-go alarm
    - Protection against moisture

1) Fibreglass-reinforced plastic

Nominal data	Air flow		Nominal voltage	Voltage range	Sound pressure level	Sound power level	Sinter sleeve bearings Ball bearings	Input power	Nominal speed	Temperature range	Service life L <sub>10</sub> (40 °C) ebm-papst Standard	Service life L <sub>10</sub> (T <sub>max</sub> ) ebm-papst Standard	Life expectancy L <sub>10</sub> IPC (40 °C) see page 17	Curve
	m <sup>3</sup> /h	CFM												
712 F/2L-005*	28	16,5	12	8...13,8	25	4,7	□	0,6	3 300	-20...+70	60 000 / 30 000	102 500	102 500	①
712 F/2M-006*	36	21,2	12	8...13,8	32	5,0	□	1,1	4 300	-20...+70	60 000 / 30 000	102 500	102 500	②
712 F	44	25,9	12	8...13,8	38	5,3	□	1,7	5 300	-20...+70	60 000 / 30 000	102 500	102 500	③
714 F	44	25,9	24	18...28	38	5,3	□	1,5	5 300	-20...+70	60 000 / 30 000	102 500	102 500	③

Subject to alternations

\*Version with 3-pin Molex plug housing 22-01-2035  
Molex Contacts 08-50-0113

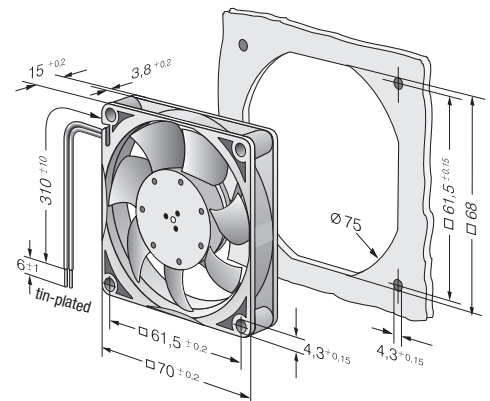
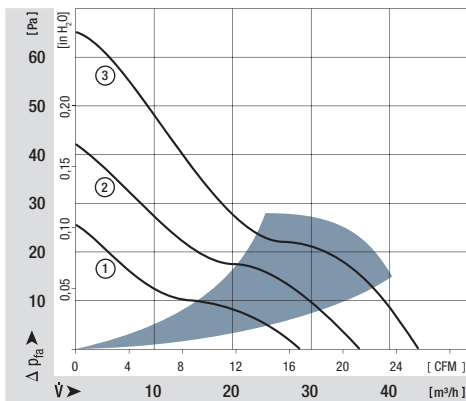

max. 117 m<sup>3</sup>/h

# DC axial fans

Series 8450 80 x 80 x 25 mm



- **Material:** Housing: GRP<sup>1)</sup> (PBT)  
Impeller: GRP<sup>1)</sup> (PA)
  - **Direction of air flow:** Exhaust over struts
  - **Direction of rotation:** Counter-clockwise, seen on rotor
  - **Connection:** Via single wires AWG 24, TR 64
  - **Highlights:** Very low-noise motor
  - **Mass:** 105 g
- **Possible special versions:**  
(See chapter DC fans - specials)
    - Speed signal
    - Go / No-go alarm
    - Alarm with limit speed
    - External temperature sensor
    - Internal temperature sensor
    - PWM control input
    - Analogue control input
    - Protection against moisture

1) Fibreglass-reinforced plastic

Nominal data	Air flow	Air flow	Nominal voltage	Voltage range	Sound pressure level	Sound power level	Sinter sleeve bearings Ball bearings	Input power	Nominal speed	Temperature range	Service life L <sub>10</sub> (40 °C) ebm-papst Standard	Service life L <sub>10</sub> (T <sub>max</sub> ) ebm-papst Standard	Life expectancy L <sub>10</sub> (IPC (40 °C) see page 17	Curve
Type	m <sup>3</sup> /h	CFM	VDC	VDC	dB(A)	Bel(A)	□ / ■	Watts	rpm	°C	Hours	Hours	Hours	Curve
8452 GL	32	18,8	12	8...15	14	3,3	□	0,4	1 700	-20...75	80 000 / 35 000	135 000	135 000	①
8452 GM	58	34,1	12	8...15	32	4,7	□	1,3	3 100	-20...75	80 000 / 35 000	135 000	135 000	②
8452 GN	68	40,0	12	8...15	36	5,0	□	1,8	3 600	-20...70	70 000 / 35 000	117 500	117 500	③
Models with 25 kHz PWM control and speed signal to 4-wire specification (see page 175).														
8452/2 GHP	75	44,1	12	10,8...13,2	38	5,3	□	2,5	4 000	-20...70	70 000 / 35 000	117 500	117 500	④
8452/2 GHHP	83	48,8	12	10,8...13,2	42	5,5	□	3,5	4 400	-20...60	65 000 / 40 000	110 000	110 000	⑤
Models with 1-30 kHz PWM control and speed signal.														
8452/2 H4P	117	68,8	12	8...15	50	6,4	■	6,8	6 200	-20...70	60 000 / 30 000	102 500	102 500	⑥
8454/2 H4P	117	68,8	24	20,0...26,4	50	6,4	■	6,8	6 200	-20...70	60 000 / 30 000	102 500	102 500	⑥

Subject to alternations

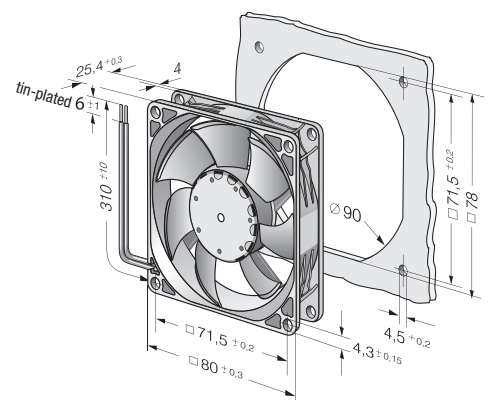
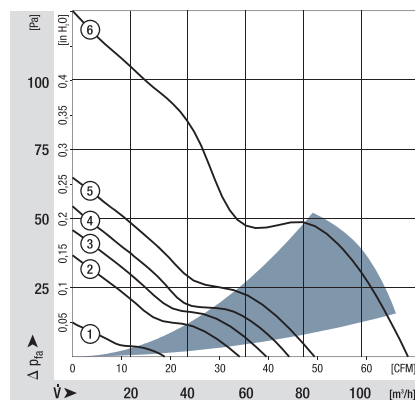

max. 79 m<sup>3</sup>/h

# DC axial fans

Series 8400 N 80 x 80 x 25 mm



- **Material:** Housing: GRP<sup>1)</sup> (PBT)  
Impeller: GRP<sup>1)</sup> (PA)
  - **Direction of air flow:** Exhaust over struts
  - **Direction of rotation:** Counter-clockwise, seen on rotor
  - **Connection:** Via single wires AWG 24, TR 64
  - **Highlights:** Some models are suitable for use at high ambient temperatures until 85 °C
  - **Mass:** 95 g
- **Possible special versions:** (See chapter DC fans - specials)
    - Speed signal
    - Go / No-go alarm
    - Alarm with limit speed
    - External temperature sensor
    - Internal temperature sensor
    - PWM control input
    - Analogue control input
    - Protection against moisture
    - Type of protection: IP 54 / IP 68

1) Fibreglass-reinforced plastic

Nominal data	Air flow		Nominal voltage	Voltage range	Sound pressure level	Sound power level	Sinter sleeve bearings Ball bearings	Input power	Nominal speed	Temperature range	Service life L <sub>10</sub> (40 °C) ebm-papst Standard	Service life L <sub>10</sub> (T <sub>max</sub> ) ebm-papst Standard	Life expectancy L <sub>10</sub> QPC (40 °C) see page 17	Curve
	m <sup>3</sup> /h	CFM												
8412 NGL	33	19,4	12	8...15	12	3,5	■	0,5	1 500	-20...+85	80 000 / 27 500	135 000	①	
8412 NLE	33	19,4	12	8...15	17	3,7	■	0,3	1 500	-20...+85	80 000 / 27 500	135 000	①	
8412 NGMLE	45	26,5	12	8...15	19	3,9	■	0,9	2 050	-20...+80	80 000 / 32 500	135 000	②	
8412 NMLE	45	26,5	12	8...15	21	4,0	■	0,6	2 050	-20...+85	80 000 / 27 500	135 000	②	
8412 NGME	58	34,1	12	8...15	26	4,3	■	1,4	2 600	-20...+75	80 000 / 35 000	135 000	③	
8412 NME	58	34,1	12	8...15	27	4,4	■	1,0	2 600	-20...+75	80 000 / 35 000	135 000	③	
8412 NG	69	40,6	12	8...15	32	4,7	■	2,0	3 100	-20...+70	70 000 / 35 000	117 500	④	
8412 N	69	40,6	12	8...15	32	4,7	■	1,7	3 100	-20...+70	70 000 / 35 000	117 500	④	
8412 NH	79	46,5	12	8...13,2	37	5,0	■	2,1	3 600	-20...+70	70 000 / 35 000	117 500	⑤	
8412 NH-217	79	46,5	12	8...15	37	5,0	■	2,5	3 600	-20...+70	70 000 / 35 000	117 500	⑤	
8414 NGL	33	19,4	24	18...28	12	3,5	■	0,9	1 500	-20...+70	80 000 / 40 000	135 000	①	
8414 NL	33	19,4	24	18...28	17	3,7	■	0,8	1 500	-20...+70	80 000 / 40 000	135 000	①	
8414 NGML	45	26,5	24	18...28	19	3,9	■	1,2	2 050	-20...+70	80 000 / 40 000	135 000	②	
8414 NML	45	26,5	24	18...28	21	4,0	■	1,1	2 050	-20...+70	80 000 / 40 000	135 000	②	
8414 NGM	58	34,1	24	18...28	26	4,3	■	1,4	2 600	-20...+70	80 000 / 40 000	135 000	③	
8414 NM	58	34,1	24	18...28	27	4,4	■	1,4	2 600	-20...+70	80 000 / 40 000	135 000	③	
8414 NG	69	40,6	24	18...28	32	4,7	■	2,2	3 100	-20...+70	70 000 / 35 000	117 500	④	
8414 N	69	40,6	24	18...28	32	4,7	■	1,8	3 100	-20...+70	70 000 / 35 000	117 500	④	
8414 NH	79	46,5	24	18...26	37	5,0	■	2,4	3 600	-20...+70	70 000 / 35 000	117 500	⑤	
8414 NH-221	79	46,5	24	18...28	37	5,0	■	2,2	3 600	-20...+70	70 000 / 35 000	117 500	⑤	
8418 N	69	40,6	48	36...56	32	4,7	■	2,0	3 100	-20...+70	70 000 / 35 000	117 500	④	

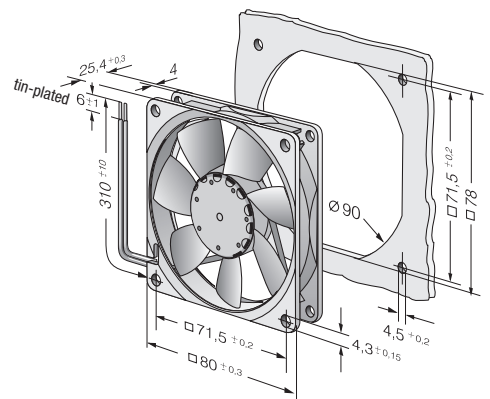
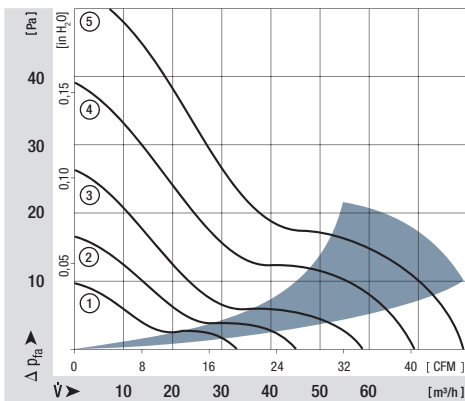

max. 58 m<sup>3</sup>/h

# DC axial fans

Series 8400 N VARIOFAN 80 x 80 x 25 mm



- **Material:** Housing: GRP<sup>1)</sup> (PBT)  
Impeller: GRP<sup>1)</sup> (PA)
  - **Direction of air flow:** Exhaust over struts
  - **Direction of rotation:** Counter-clockwise, seen on rotor
  - **Connection:** Via single wires AWG 24, TR 64
  - **Highlights:** Automatic speed adjustment with temperature sensor
  - **Mass:** 95 g
- **Possible special versions:** (See chapter DC fans - specials)
    - Speed signal
    - Go / No-go alarm
    - External temperature sensor
    - Internal temperature sensor
    - Protection against moisture

1) Fibreglass-reinforced plastic

Nominal data		Air flow		Nominal voltage	Voltage range	Sound pressure level	Sound power level	Sinter sleeve bearings Ball bearings	Input power	Nominal speed	Temperature range	Service life L <sub>10</sub> (40 °C) ebm-papst Standard	Service life L <sub>10</sub> (T <sub>max</sub> ) ebm-papst Standard	Life expectancy L <sub>10</sub> (IPC (40 °C) see page 17	Curve
Type		m <sup>3</sup> /h	CFM	VDC	VDC	dB(A)	Bel(A)	□ / ■	Watts	rpm	°C	Hours	Hours	Hours	
30°C 50°C	8412 NGLV	20 33	11,8 19,4	12	10...14	< 10 12	< 3 3,5	□	0,9 1,1	900 1 500	-20...+65	80 000 / 45 000	135 000	135 000	① ②
30°C 50°C	8412 NGMLV	27 45	15,9 26,6	12	8...14	< 10 19	3,0 3,9	□	1,1 1,5	1 200 2 050	-20...+65	80 000 / 45 000	135 000	135 000	③ ④
30°C 50°C	8412 NGMI	35 58	20,6 34,1	12	8...14	< 13 26	3,5 4,3	□	1,4 2,0	1 600 2 600	-20...+65	80 000 / 45 000	135 000	135 000	⑤ ⑥

Subject to alternations

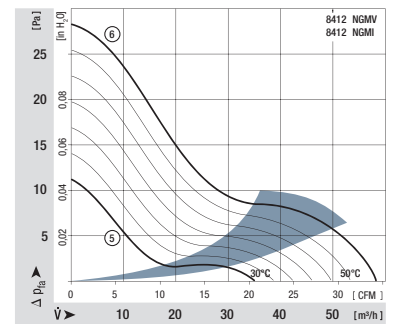
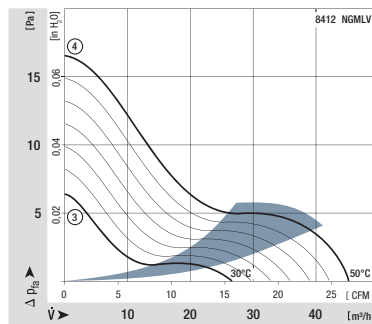
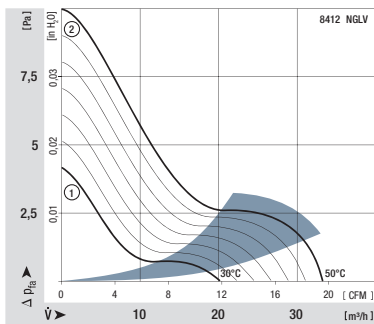

## V-Types

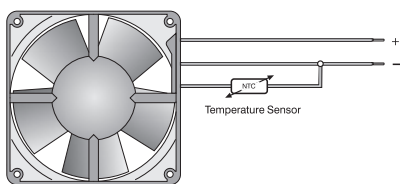

The temperature sensor for controlling the motor speed is not included in delivery. Temperature sensor LZ 370 see accessories.

## I-Types

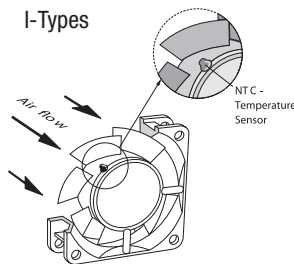

Temperature sensor (NTC-resistor) for controlling the motor speed is positioned directly in the air flow.

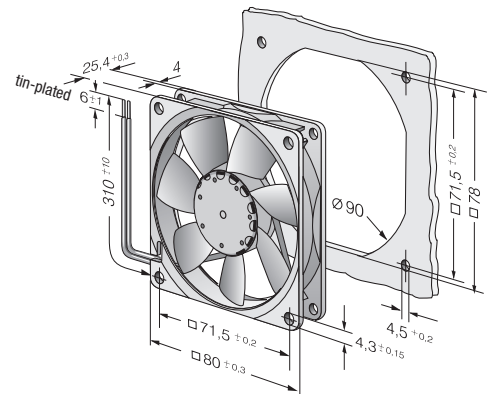



max. 80 m<sup>3</sup>/h

# DC axial fans

Series 8300 80 x 80 x 32 mm



- **Material:** Housing: GRP<sup>1)</sup> (PBT)  
Impeller: GRP<sup>1)</sup> (PA)
  - **Direction of air flow:** Exhaust over struts
  - **Direction of rotation:** Clockwise, seen on rotor
  - **Connection:** Via single wires AWG 22, TR 64
  - **Mass:** 170 g
- **Possible special versions:**  
(See chapter DC fans - specials)
    - Speed signal
    - Go / No-go alarm
    - Alarm with limit speed
    - External temperature sensor
    - Internal temperature sensor
    - PWM control input
    - Analogue control input
    - Protection against moisture
    - Protection against fog
    - Type of protection: IP 54 / IP 68

1) Fibreglass-reinforced plastic

Nominal data	Air flow		Nominal voltage	Voltage range	Sound pressure level	Sound power level	Sinter sleeve bearings Ball bearings	Input power	Nominal speed	Temperature range	Service life L <sub>10</sub> (40 °C) ebm-papst Standard	Service life L <sub>10</sub> (T <sub>max</sub> ) ebm-papst Standard	Life expectancy L <sub>10</sub> IPC (40 °C) see page 17	Curve
	m <sup>3</sup> /h	CFM												
8312 L	32	18,8	12	6...15	24	4,0	■	1,2	2 000	-20...+75	80 000 / 32 500	135 000	①	
8312 M	48	28,3	12	6...15	34	5,0	■	2,2	3 000	-20...+75	70 000 / 27 500	117 500	②	
8312	54	31,8	12	6...15	36	5,2	■	2,6	3 300	-20...+75	70 000 / 27 500	117 500	③	
8312 HL	67	39,4	12	6...15	43	5,8	■	4,0	4 200	-20...+75	62 500 / 25 000	105 000	④	
8312 H	80	47,1	12	6...12,6	48	6,2	■	6,4	5 000	-20...+60	55 000 / 35 000	92 500	⑤	
8314 L	32	18,8	24	12...31,5	24	4,0	■	1,0	2 000	-20...+75	80 000 / 32 500	135 000	①	
8314 M	48	28,3	24	12...31,5	34	5,0	■	2,3	3 000	-20...+75	70 000 / 27 500	117 500	②	
8314	54	31,8	24	12...31,5	36	5,2	■	2,7	3 300	-20...+75	70 000 / 27 500	117 500	③	
8314 HL	67	39,4	24	12...31,5	43	5,8	■	4,3	4 200	-20...+75	62 500 / 25 000	105 000	④	
8314 H	80	47,1	24	12...28	48	6,2	■	6,0	5 000	-20...+75	55 000 / 22 500	92 500	⑤	
8318	54	31,8	48	36...60	36	5,2	■	3,0	3 300	-20...+75	70 000 / 27 500	117 500	③	
8318 HL	67	39,4	48	36...60	43	5,8	■	4,2	4 200	-20...+75	62 500 / 25 000	105 000	④	
8318 H	80	47,1	48	36...60	48	6,2	■	6,2	5 000	-20...+65	55 000 / 30 000	92 500	⑤	

Subject to alterations

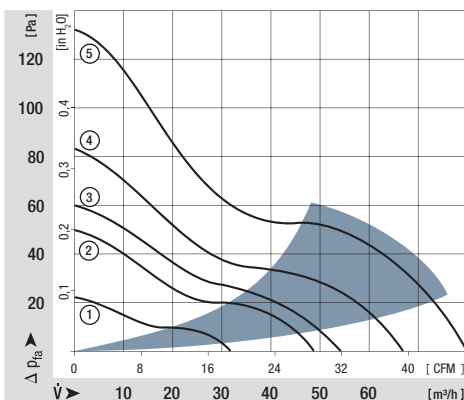

Rotor protrusion max. 0,4 mm.

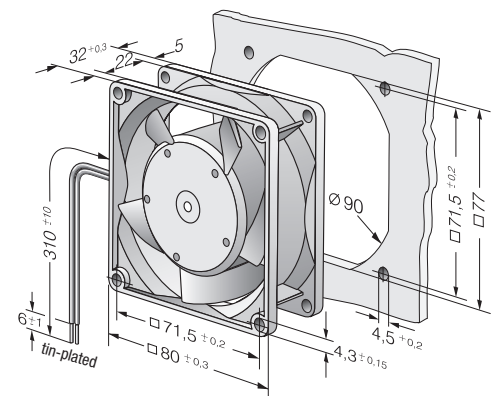



max. 222 m<sup>3</sup>/h

# DC axial fans

Series 8200 J 80 x 80 x 38 mm



- **Material:** Housing: GRP<sup>1)</sup> (PBT)  
Impeller: GRP<sup>1)</sup> (PA)
  - **Direction of air flow:** Exhaust over struts
  - **Direction of rotation:** Counter-clockwise, seen on rotor
  - **Connection:** Via single wires AWG 24 (H3 and H4: AWG 22), TR 64
  - **Mass:** 160 g (H3 and H4: 200 g)
- **Possible special versions:** (See chapter DC fans - specials)
    - Speed signal
    - Go / No-go alarm
    - Alarm with limit speed
    - External temperature sensor
    - Internal temperature sensor
    - PWM control input
    - Analogue control input
    - Protection against moisture
    - Type of protection: IP 54 / IP 68

1) Fibreglass-reinforced plastic

Nominal data	Air flow		Nominal voltage	Voltage range	Sound pressure level	Sound power level	Sinter sleeve bearings Ball bearings	Input power*	Nominal speed	Temperature range	Service life L <sub>10</sub> (40 °C) ebm-papst Standard	Service life L <sub>10</sub> (T <sub>max</sub> ) ebm-papst Standard	Life expectancy L <sub>10</sub> (IPC (40 °C) see page 17	Curve
	m <sup>3</sup> /h	CFM												
8212 JN	132	78	12	7...13,8	55	6,6	■	10	8400	-20...+70	62 500 / 32 500	105 000	105 000	①
8212 JH3 <i>S-Force</i>	190	112	12	6...13,8	66	7,3	■	26*	12 000	-20...+70	55 000 / 27 500	92 500	92 500	②
8212 JH4 <i>S-Force</i>	222	131	12	6...13,8	71	7,8	■	39*	14 000	-20...+70	50 000 / 25 000	85 000	85 000	③
8214 JN	132	78	24	18...26,4	55	6,6	■	11	8400	-20...+70	62 500 / 32 500	105 000	105 000	①
8214 JH3 <i>S-Force</i>	190	112	24	12...27,6	66	7,3	■	26*	12 000	-20...+70	55 000 / 27 500	92 500	92 500	②
8214 JH4 <i>S-Force</i>	222	131	24	12...27,6	71	7,8	■	38*	14 000	-20...+70	50 000 / 25 000	85 000	85 000	③
8218 JN	132	78	48	36...53	55	6,6	■	11	8400	-20...+70	62 500 / 32 500	105 000	105 000	①
8218 JH3 <i>S-Force</i>	190	112	48	36...53	66	7,3	■	25*	12 000	-20...+70	55 000 / 27 500	92 500	92 500	②
8218 JH4 <i>S-Force</i>	222	131	48	20...58	71	7,8	■	36*	14 000	-20...+70	50 000 / 25 000	85 000	85 000	③

Subject to alternations

8200 JH3 and JH4 also available as standard with PWM control input and speed signal.  
Speed control range from 2000 rpm up to maximum nominal speed. Stationary at 0 % PWM, maximum speed at sensor break.  
\* Input power at free air flow, these values can be significantly higher in the operating point.

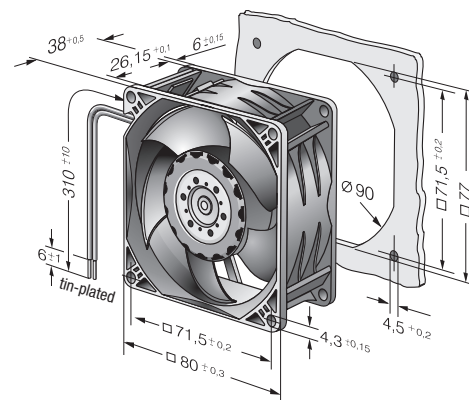
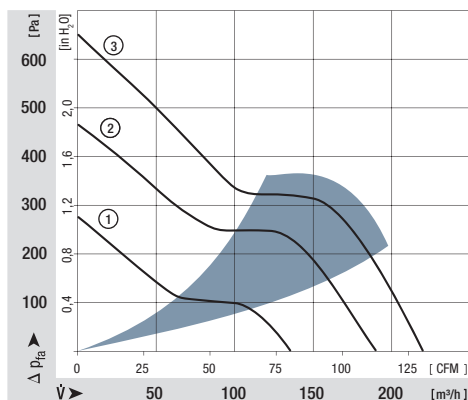

max. 102 m<sup>3</sup>/h

# DC axial fans

Series 3400 N 92 x 92 x 25 mm



- **Material:** Housing: GRP<sup>1)</sup> (PBT)  
Impeller: GRP<sup>1)</sup> (PA)
  - **Direction of air flow:** Exhaust over struts
  - **Direction of rotation:** Counter-clockwise, seen on rotor
  - **Connection:** Via single wires AWG 24, TR 64
  - **Mass:** 100 g
- **Possible special versions:**  
(See chapter DC fans - specials)
    - Speed signal
    - Go / No-go alarm
    - Alarm with limit speed
    - External temperature sensor
    - Internal temperature sensor
    - PWM control input
    - Analogue control input
    - Protection against moisture
    - Type of protection: IP 54 / IP 68

1) Fibreglass-reinforced plastic

Nominal data	Air flow		Nominal voltage	Voltage range	Sound pressure level	Sound power level	Sinter sleeve bearings Ball bearings	Input power	Nominal speed	Temperature range	Service life L <sub>10</sub> (40 °C) ebm-papst Standard	Service life L <sub>10</sub> (T <sub>max</sub> ) ebm-papst Standard	Life expectancy L <sub>10</sub> (IPC (40 °C) see page 17	Curve
	m <sup>3</sup> /h	CFM												
3412 NGLE	61	35,9	12	8...15	23	4,0	■	1,1	1 950	-20...+80	80 000 / 22 500	135 000	①	
3412 NLE	61	35,9	12	8...15	23	4,0	■	0,8	1 950	-20...+85	80 000 / 17 500	135 000	①	
3412 NGME	72	42,4	12	8...15	28	4,3	■	1,6	2 300	-20...+75	75 000 / 27 500	127 500	②	
3412 NME	72	42,4	12	8...15	28	4,3	■	1,1	2 300	-20...+75	75 000 / 27 500	127 500	②	
3412 NG	84	49,4	12	8...15	32	4,7	■	1,9	2 700	-20...+70	70 000 / 35 000	117 500	③	
3412 N	84	49,4	12	8...15	32	4,7	■	1,7	2 700	-20...+70	70 000 / 35 000	117 500	③	
3412 NGH	94	55,3	12	8...15	36	5,0	■	2,3	3 000	-20...+70	70 000 / 35 000	117 500	④	
3412 NH	94	55,3	12	8...15	36	5,0	■	2,1	3 000	-20...+70	70 000 / 35 000	117 500	④	
3412 NGHH	102	60,0	12	8...13,2	39	5,1	■	3,2	3 250	-20...+60	70 000 / 45 000	127 500	⑤	
3412 NHH	102	60,0	12	8...13,2	39	5,1	■	2,9	3 250	-20...+60	70 000 / 45 000	127 500	⑤	
3412 NHH-379	102	60,0	12	8...15	39	5,1	■	2,7	3 250	-20...+70	70 000 / 35 000	117 500	⑤	
3414 NGL	61	35,9	24	18...28	23	4,0	■	1,4	1 950	-20...+70	80 000 / 40 000	135 000	①	
3414 NL	61	35,9	24	18...28	23	4,0	■	1,1	1 950	-20...+70	80 000 / 40 000	135 000	①	
3414 NGM	72	42,4	24	18...28	28	4,3	■	1,7	2 300	-20...+70	75 000 / 37 500	127 500	②	
3414 NM	72	42,4	24	18...28	28	4,3	■	1,4	2 300	-20...+70	75 000 / 37 500	127 500	②	
3414 NG	84	49,4	24	18...28	32	4,7	■	2,5	2 700	-20...+70	70 000 / 35 000	117 500	③	
3414 N	84	49,4	24	18...28	32	4,7	■	2,1	2 700	-20...+70	70 000 / 35 000	117 500	③	
3414 NGH	94	55,3	24	18...26	36	5,0	■	3,0	3 000	-20...+70	70 000 / 35 000	117 500	④	
3414 NH	94	55,3	24	18...26	36	5,0	■	2,3	3 000	-20...+70	70 000 / 35 000	117 500	④	
3414 NGHH	102	60,0	24	18...26	39	5,1	■	3,2	3 250	-20...+70	70 000 / 35 000	117 500	⑤	
3414 NGH-389	102	60,0	24	18...28	39	5,1	■	3,2	3 250	-20...+70	70 000 / 35 000	117 500	⑤	
3414 NHH	102	60,0	24	18...26	39	5,1	■	3,1	3 250	-20...+70	70 000 / 35 000	117 500	⑤	
3414 NHH-386	102	60,0	24	18...28	39	5,1	■	3,2	3 250	-20...+70	70 000 / 35 000	117 500	⑤	
3418 N	84	49,4	48	36...56	32	4,7	■	2,4	2 700	-20...+70	70 000 / 35 000	117 500	③	

Other 48 VDC models on request.

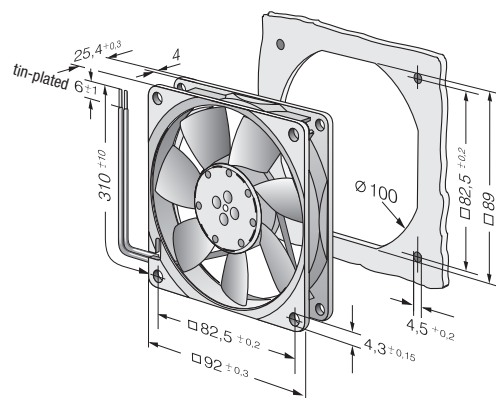
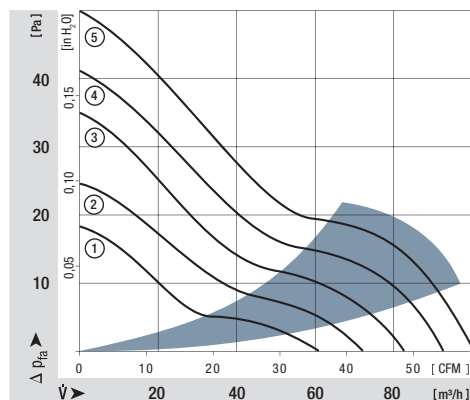

max. 84 m<sup>3</sup>/h

# DC axial fans

Series 3400 N VARIOFAN 92 x 92 x 25 mm



- **Material:** Housing: GRP<sup>1)</sup> (PBT)  
Impeller: GRP<sup>1)</sup> (PA)
  - **Direction of air flow:** Exhaust over struts
  - **Direction of rotation:** Counter-clockwise, seen on rotor
  - **Connection:** Via single wires AWG 24, TR 64
  - **Highlights:** Automatic speed adjustment with temperature sensor
  - **Mass:** 100 g
- **Possible special versions:**  
(See chapter DC fans - specials)
    - Speed signal
    - Go / No-go alarm
    - External temperature sensor
    - Internal temperature sensor
    - Protection against moisture

1) Fibreglass-reinforced plastic

Nominal data		Air flow	Air flow	Nominal voltage	Voltage range	Sound pressure level	Sound power level	Sinter sleeve bearings Ball bearings	Input power	Nominal speed	Temperature range	Service life L <sub>10</sub> (40 °C) ebm-papst Standard	Service life L <sub>10</sub> (T <sub>max</sub> ) ebm-papst Standard	Life expectancy L <sub>10</sub> (IPC (40 °C) see page 17	Curve
Type		m <sup>3</sup> /h	CFM	VDC	VDC	dB(A)	Bel(A)	□ / ■	Watts	rpm	°C	Hours	Hours	Hours	
30°C 50°C	3412 NGMV	44 72	25,9 42,4	12	8...14	14 28	3,5 4,3	□	1,5 2,0	1 400 2 300	-20...+65	75 000 / 42 500	127 500	127 500	① ②
30°C 50°C	3412 NGV	50 84	29,4 49,4	12	8...12,6	16 32	3,7 4,7	□	1,6 2,5	1 600 2 700	-20...+65	75 000 / 42 500	127 500	127 500	③ ④

Subject to alternations

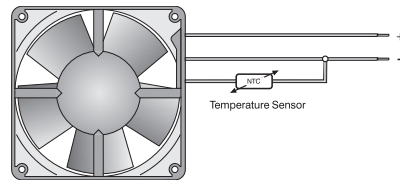
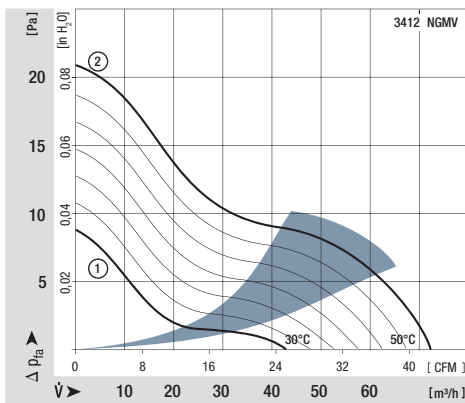

The temperature sensor for controlling the motor speed is not included in delivery.  
Temperature sensor LZ 370 see accessories.

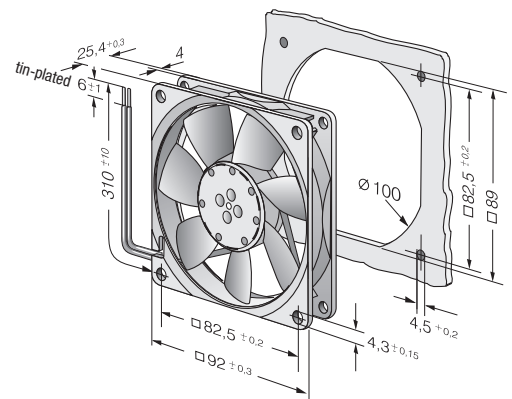
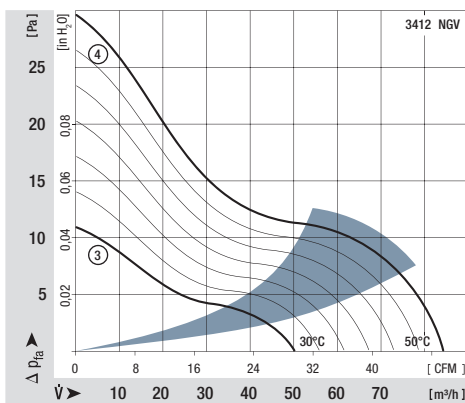

max. 107 m<sup>3</sup>/h

# DC axial fans

Series 3300 92 x 92 x 32 mm



- **Material:** Housing: GRP<sup>1)</sup> (PBT)  
Impeller: GRP<sup>1)</sup> (PA)
- **Direction of air flow:** Exhaust over struts
- **Direction of rotation:** Clockwise, seen on rotor
- **Connection:** Via single wires AWG 22, TR 64
- **Mass:** 190 g

- **Possible special versions:**  
(See chapter DC fans - specials)
  - Speed signal
  - Go / No-go alarm
  - Alarm with limit speed
  - External temperature sensor
  - Internal temperature sensor
  - PWM control input
  - Analogue control input
  - Protection against moisture
  - Protection against salt fog
  - Type of protection: IP 54 / IP 68

1) Fibreglass-reinforced plastic

Nominal data	Air flow		Nominal voltage	Voltage range	Sound pressure level	Sound power level	Sinter sleeve bearings Ball bearings	Input power	Nominal speed	Temperature range	Service life L <sub>10</sub> (40 °C) ebm-papst Standard	Service life L <sub>10</sub> (T <sub>max</sub> ) ebm-papst Standard	Life expectancy L <sub>10</sub> IPC (40 °C) see page 17	Curve
	m <sup>3</sup> /h	CFM												
3312 L	56	33,0	12	6...15	29	4,5	■	1,5	2 150	-20...+75	80 000 / 35 000	135 000	①	
3312 GM	68	40,0	12	6...15	34	4,8	□	1,8	2 600	-20...+75	70 000 / 30 000	117 500	②	
3312 M	68	40,0	12	6...15	34	4,8	■	1,8	2 600	-20...+75	70 000 / 30 000	117 500	②	
3312	80	47,1	12	6...15	37	5,2	■	2,5	3 000	-20...+75	70 000 / 30 000	117 500	③	
3312-177	93	54,7	12	6...15	43	5,7	■	3,5	3 400	-20...+75	65 000 / 27 500	110 000	⑤	
3314 G	80	47,1	24	12...28	37	5,2	□	2,5	3 000	-20...+75	70 000 / 30 000	117 500	③	
3314	80	47,1	24	12...28	37	5,2	■	2,5	3 000	-20...+75	70 000 / 30 000	117 500	③	
3314-140	85	50,0	24	12...28	40	5,4	■	3,0	3 200	-20...+75	70 000 / 30 000	117 500	④	
3314 H	107	63,0	24	12...28	47	6,0	■	5,0	4 000	-20...+75	57 500 / 25 000	97 500	⑥	
3318	80	47,1	48	36...60	37	5,2	■	2,4	3 000	-20...+75	70 000 / 30 000	117 500	③	
3318 H	107	63,0	48	36...60	47	6,0	■	4,9	4 000	-20...+60	57 500 / 32 500	97 500	⑥	

Subject to alternations

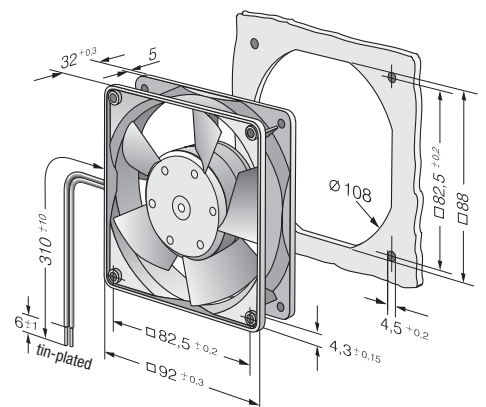
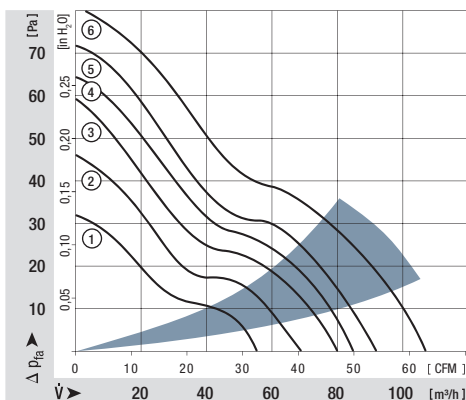

max. 133 m<sup>3</sup>/h

# DC axial fans

Series 3300 N 92 x 92 x 32 mm



- **Material:** Housing: GRP<sup>1)</sup> (PBT)  
Impeller: GRP<sup>1)</sup> (PA)
  - **Direction of air flow:** Exhaust over struts
  - **Direction of rotation:** Clockwise, seen on rotor
  - **Connection:** Via single wires AWG 24  
UL 1061, TR 64
  - **Mass:** 190 g
- **Possible special versions:**  
(See chapter DC fans - specials)
    - Speed signal
    - Go / No-go alarm
    - External temperature sensor
    - Internal temperature sensor
    - PWM control input
    - Analogue control input
    - Protection against moisture
    - Protection against salt fog
    - Type of protection: IP 54 / IP 68

1) Fibreglass-reinforced plastic

Nominal data		Air flow	Air flow	Nominal voltage	Voltage range	Sound pressure level	Sound power level	Sintec sleeve bearings Ball bearings	Input power	Nominal speed	Temperature range	Service life L <sub>10</sub> (40 °C) ebm-papst Standard	Service life L <sub>10</sub> (T <sub>max</sub> ) ebm-papst Standard	Life expectancy L <sub>10</sub> (IPC (40 °C) see page 17	Curve
Type		m <sup>3</sup> /h	CFM	VDC	VDC	dB(A)	Bel(A)	■ / ■	Watts	rpm	°C	Hours	Hours		
3312 NL		56	33	12	6...15	23	4,0	■	0,8	1 850	-20...+75	80 000 / 35 000	135 000	①	
3312 NM		68	40	12	6...15	29	4,3	■	1,3	2 250	-20...+75	70 000 / 30 000	117 500	②	
3312 NN		80	47	12	6...15	34	4,7	■	1,7	2 650	-20...+75	70 000 / 30 000	117 500	③	
3312 NH		93	54	12	6...15	36,5	5,0	■	2,5	3 050	-20...+75	65 000 / 27 500	110 000	④	
3312 NHH		107	63	12	6...15	40	5,4	■	3,4	3 450	-20...+75	57 500 / 25 000	97 500	⑤	
3312 NH3		133	78	12	6...15	48	5,9	■	6,4	4 350	-20...+70	50 000 / 25 000	85 000	⑥	

Subject to alternations

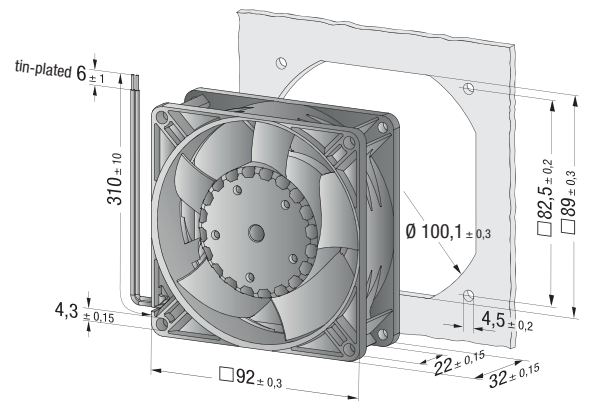
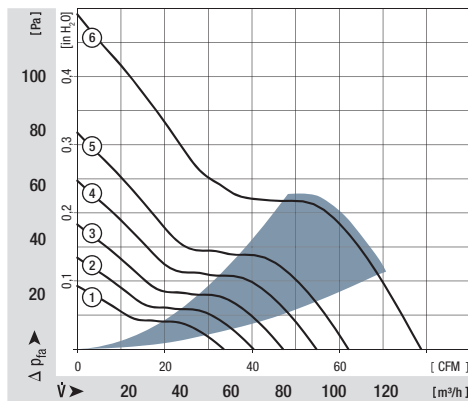



max. 280 m<sup>3</sup>/h

# DC axial fans

Series 3200 J 92 x 92 x 38 mm



- **Material:** Housing: GRP<sup>1)</sup> (PBT)  
Impeller: GRP<sup>1)</sup> (PA)
  - **Direction of air flow:** Exhaust over struts
  - **Direction of rotation:** Clockwise, seen on rotor
  - **Connection:** Via single wires AWG 24  
(H3 and H4: AWG 22), TR 64
  - **Mass:** 240 g (H3 and H4: 280 g)
- **Possible special versions:**  
(See chapter DC fans - specials)
    - Speed signal
    - Go / No-go alarm
    - Alarm with limit speed
    - External temperature sensor
    - Internal temperature sensor
    - PWM control input
    - Analogue control input
    - Protection against moisture
    - Type of protection: IP 54 / IP 68

1) Fibreglass-reinforced plastic

Nominal data	Air flow		Nominal voltage	Voltage range	Sound pressure level	Sound power level	Sinter sleeve bearings Ball bearings	Input power*	Nominal speed	Temperature range	Service life L <sub>10</sub> (40 °C) ebm-papst Standard	Service life L <sub>10</sub> (T <sub>max</sub> ) ebm-papst Standard	Life expectancy L <sub>10</sub> IPC (40 °C) see page 17	Curve
	m <sup>3</sup> /h	CFM												
3212 JN	130	76,5	12	7...13,8	51	6,1	■	7,5	6 000	-20 ...+70	70 000 / 35 000	117 500	①	
3212 JH	146	86,0	12	7...15	55	6,4	■	9,0	6 800	-20 ...+70	70 000 / 35 000	117 500	②	
3212 JH3 <i>S-Force</i>	237	139,5	12	6...13,8	69	7,8	■	31,0*	11 000	-20 ...+70	65 000 / 32 500	110 000	③	
3212 JH4 <i>S-Force</i>	280	164,8	12	6...13,8	73	8,2	■	50,0*	13 000	-20 ...+70	60 000 / 30 000	110 000	④	
3214 JN	130	76,5	24	11...28	51	6,1	■	6,5	6 000	-20 ...+70	70 000 / 35 000	117 500	①	
3214 JH	146	86,0	24	12...30	55	6,4	■	9,0	6 800	-20 ...+70	70 000 / 35 000	117 500	②	
3214 JH3 <i>S-Force</i>	237	139,5	24	12...27,6	69	7,8	■	30,0*	11 000	-20 ...+70	65 000 / 32 500	110 000	③	
3214 JH4 <i>S-Force</i>	280	164,8	24	12...27,6	73	8,2	■	50,0*	13 000	-20 ...+70	60 000 / 30 000	110 000	④	
3218 JN	130	76,5	48	36...56	51	6,1	■	7,0	6 000	-20 ...+70	70 000 / 35 000	117 500	①	
3218 JH	146	86,0	48	36...53	55	6,4	■	9,5	6 800	-20 ...+70	70 000 / 35 000	117 500	②	
3218 JH3 <i>S-Force</i>	237	139,5	48	20...58,0	69	7,8	■	29,0*	11 000	-20 ...+70	65 000 / 32 500	110 000	③	
3218 JH4 <i>S-Force</i>	280	164,8	48	20...58,0	73	8,2	■	50,0*	13 000	-20 ...+70	60 000 / 30 000	110 000	④	

Subject to alternations

3200 JH3 and JH4 also available as standard with PWM control input and speed signal.  
Speed control range from 2000 rpm up to maximum nominal speed. Stationary at 0 % PWM, maximum speed at sensor break.  
\* Input power at free air flow, these values can be significantly higher in the operating point.

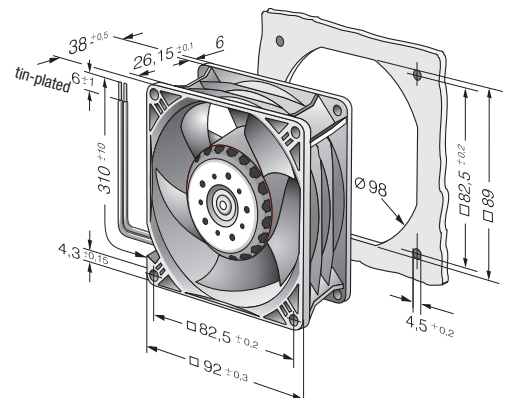
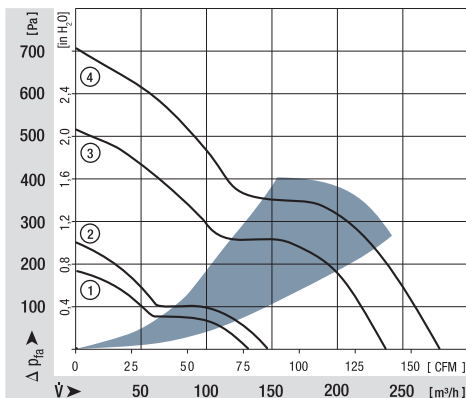



max. 270 m<sup>3</sup>/h  
**S-Panther**

## DC axial fans

Series 3250 J 92 x 92 x 38 mm



- **Material:** Housing: GRP<sup>1)</sup> (PBT)  
Impeller: GRP<sup>1)</sup> (PA)
  - **Direction of air flow:** Exhaust over struts
  - **Direction of rotation:** Clockwise, seen on rotor
  - **Connection:** Via single wires AWG 22, TR 64
  - **Mass:** 240 g
- **Possible special versions:**  
(See chapter DC fans - specials)
    - Speed signal
    - Go / No-go alarm
    - External temperature sensor
    - Internal temperature sensor
    - PWM control input
    - Analogue control input
    - Protection against moisture
    - Protection against salt fog
    - Type of protection: IP 54 / IP 68

1) Fibreglass-reinforced plastic

Nominal data	Air flow		Nominal voltage	Voltage range	Sound pressure level	Sound power level	Sinter sleeve bearings Ball bearings	Input power*	Nominal speed	Temperature range	Service life L <sub>10</sub> (40 °C) ebm-papst Standard	Service life L <sub>10</sub> (T <sub>max</sub> ) ebm-papst Standard	Life expectancy L <sub>10</sub> (IPC (40 °C) see page 17	Curve
	m <sup>3</sup> /h	CFM												
3258 JHP	145	85	48	36...56	47	5,8	■	5,3	4 100	-20...+70	85 000 / 42 500	142 500	①	
3258 JHHP	235	138	48	36...56	59	7,2	■	22,6	6 650	-20...+70	80 000 / 40 000	135 000	②	
3258 JH3P	270	158	48	36...56	63	7,7	■	34,3	7 600	-20...+70	75 000 / 37 500	127 500	③	

Subject to alternations

12 V and 24 V variants also available on request.

\* Input power at free air flow, these values can be significantly higher in the operating point.

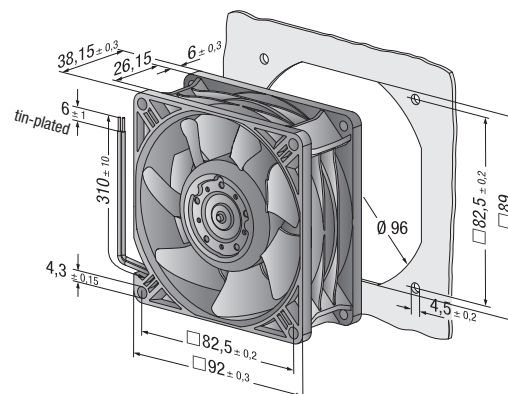
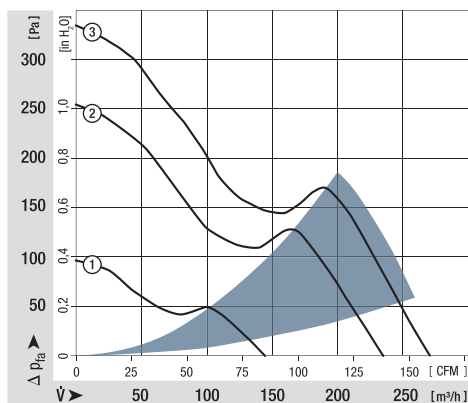

max. 170 m<sup>3</sup>/h

# DC axial fans

Series 4400 F 119 x 119 x 25 mm



- **Material:** Housing: GRP<sup>1)</sup> (PBT)  
Impeller: GRP<sup>1)</sup> (PA)
  - **Direction of air flow:** Exhaust over struts
  - **Direction of rotation:** Counter-clockwise, seen on rotor
  - **Connection:** Via single wires AWG 24, TR 64
  - **Highlights:** Ball bearings and plain bearings available
  - **Mass:** 175 g
- **Possible special versions:** (See chapter DC fans - specials)
    - Speed signal
    - Go / No-go alarm
    - Alarm with limit speed
    - External temperature sensor
    - Internal temperature sensor
    - PWM control input
    - Analogue control input
    - Protection against moisture

1) Fibreglass-reinforced plastic

Nominal data	Air flow		Nominal voltage	Voltage range	Sound pressure level	Sound power level	Sinter sleeve bearings Ball bearings	Input power	Nominal speed	Temperature range	Service life L <sub>10</sub> (40 °C) ebm-papst Standard	Service life L <sub>10</sub> (T <sub>max</sub> ) ebm-papst Standard	Life expectancy L <sub>10</sub> IPC (40 °C) see page 17	Curve
	m <sup>3</sup> /h	CFM												
4412 FGL	94	55	12	7...14	26	3,9	□	1,3	1 600	-20...+75	80 000 / 35 000	135 000	①	
4412 FGML	114	67	12	7...12,6	32	4,3	□	2,0	1 950	-20...+75	75 000 / 32 500	127 500	②	
4412 FML	114	67	12	7...12,6	32	4,3	■	2,0	1 950	-20...+75	75 000 / 32 500	127 500	②	
4412 FGM	140	82	12	7...12,6	38	4,8	□	3,2	2 400	-20...+75	70 000 / 30 000	117 500	③	
4412 FM	140	82	12	7...12,6	38	4,8	■	3,2	2 400	-20...+75	70 000 / 30 000	117 500	③	
4412 FG	170	100	12	8...12,6	43	5,3	□	5,3	2 900	-20...+60	60 000 / 37 500	102 500	④	
4412 F	170	100	12	8...12,6	43	5,3	■	5,3	2 900	-20...+60	60 000 / 37 500	102 500	④	
4414 FL	94	55	24	18...28	26	3,9	■	1,2	1 600	-20...+75	80 000 / 35 000	135 000	①	
4414 FM	140	82	24	12...28	38	4,8	■	3,1	2 400	-20...+75	70 000 / 30 000	117 500	③	
4414 FG	170	100	24	12...28	43	5,3	□	5,0	2 900	-20...+60	60 000 / 37 500	102 500	④	
4414 F	170	100	24	12...28	43	5,3	■	5,0	2 900	-20...+60	60 000 / 37 500	102 500	④	
4418 FG	170	100	48	28...53	43	5,3	□	5,4	2 900	-20...+60	60 000 / 37 500	102 500	④	
4418 F	170	100	48	28...53	43	5,3	■	5,4	2 900	-20...+60	60 000 / 37 500	102 500	④	

Subject to alternations

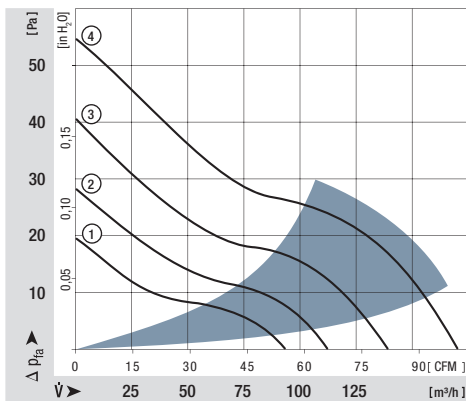
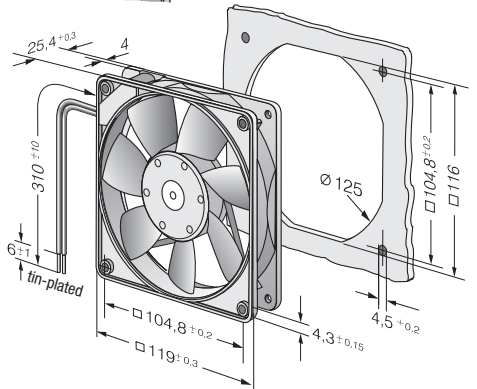
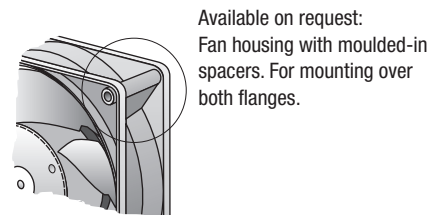

max. 225 m<sup>3</sup>/h

# DC axial fans

Series 4400 FN 119 x 119 x 25 mm



- **Material:** Housing: GRP<sup>1)</sup> (PBT)  
Impeller: GRP<sup>1)</sup> (PA)
  - **Direction of air flow:** Exhaust over struts
  - **Direction of rotation:** Counter-clockwise, seen on rotor
  - **Connection:** Via single wires AWG 22, TR 64
  - **Mass:** 240 g
- **Possible special versions:**  
(See chapter DC fans - specials)
    - Speed signal
    - Go / No-go alarm
    - Alarm with limit speed
    - External temperature sensor
    - Internal temperature sensor
    - PWM control input
    - Analogue control input
    - Protection against moisture

1) Fibreglass-reinforced plastic

Nominal data		Air flow	Air flow	Nominal voltage	Voltage range	Sound pressure level	Sound power level	Sintec sleeve bearings Ball bearings	Input power	Nominal speed	Temperature range	Service life L <sub>10</sub> (40 °C) ebm-papst Standard	Service life L <sub>10</sub> (T <sub>max</sub> ) ebm-papst Standard	Life expectancy L <sub>10</sub> (IPC (40 °C) see page 17	Curve
Type		m <sup>3</sup> /h	CFM	VDC	VDC	dB(A)	Bel(A)	■ / ■	Watts	rpm	°C	Hours	Hours		
4412 FNH		225	132	12	9...13,2	55	6,7	■	12	5 400	-20...+70	60 000 / 30 000	102 500	②	
4414 FNN		200	118	24	14...28	52	6,5	■	8,3	4 850	-20...+70	60 000 / 30 000	102 500	①	
4414 FNH		225	132	24	18...26,4	55	6,7	■	12	5 400	-20...+70	60 000 / 30 000	102 500	②	
4418 FNH		225	132	48	36...53	55	6,7	■	12	5 400	-20...+70	60 000 / 30 000	102 500	②	

Subject to alternations

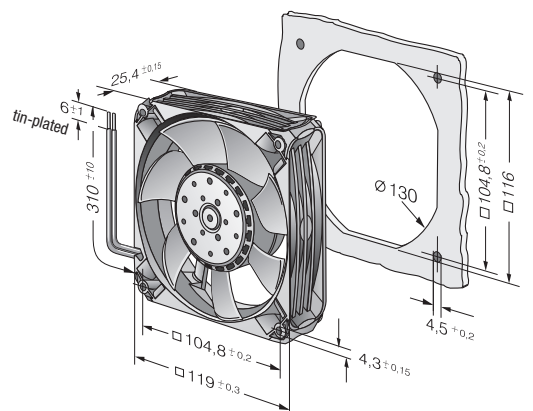
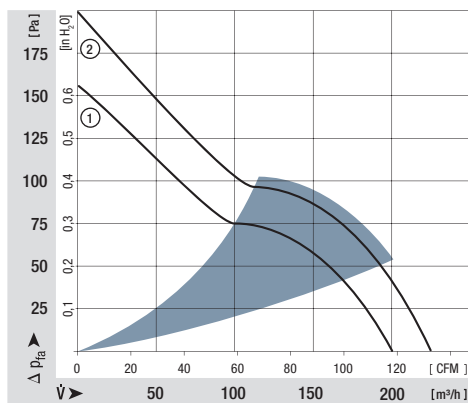

max. 204 m<sup>3</sup>/h

# DC axial fans

Series 4300 119 x 119 x 32 mm



- **Material:** Housing: GRP<sup>1)</sup> (PBT)  
Impeller: GRP<sup>1)</sup> (PA)
  - **Direction of air flow:** Exhaust over struts
  - **Direction of rotation:** Clockwise, seen on rotor
  - **Connection:** Via single wires AWG 22, TR 64
  - **Highlights:** Ball bearings and plain bearings available
  - **Mass:** 220 g
- **Possible special versions:**  
(See chapter DC fans - specials)
    - Speed signal
    - Go / No-go alarm
    - Alarm with limit speed
    - External temperature sensor
    - Internal temperature sensor
    - PWM control input
    - Analogue control input
    - Protection against moisture
    - Protection against salt fog
    - Type of protection: IP 54 / IP 68

1) Fibreglass-reinforced plastic

Nominal data	Air flow		Nominal voltage	Voltage range	Sound pressure level	Sound power level	Sinter sleeve bearings Ball bearings	Input power	Nominal speed	Temperature range	Service life L <sub>10</sub> (40 °C) ebm-papst Standard	Service life L <sub>10</sub> (T <sub>max</sub> ) ebm-papst Standard	Life expectancy L <sub>10</sub> IPC (40 °C) see page 17	Curve
	m <sup>3</sup> /h	CFM												
4312 GL	95	56	12	6...15	30	4,3	□	1,2	1 550	-20...+75	80 000 / 35 000	135 000	①	
4312 L	95	56	12	6...15	30	4,3	■	1,2	1 550	-20...+75	80 000 / 35 000	135 000	①	
4312 GM	140	82	12	6...15	39	5,3	□	3,1	2 300	-20...+75	70 000 / 30 000	117 500	②	
4312 M	140	82	12	6...15	39	5,3	■	3,1	2 300	-20...+75	70 000 / 30 000	117 500	②	
4312 G	170	100	12	6...15	45	5,8	□	5,0	2 800	-20...+70	62 500 / 30 000	105 000	③	
4312	170	100	12	6...15	45	5,8	■	5,0	2 800	-20...+70	62 500 / 30 000	105 000	③	
4312-179	204	120	12	6...13,2	51	6,4	■	9,4	3 400	-20...+65	47 500 / 27 500	80 000	⑤	
4314 L	95	56	24	12...28	30	4,3	■	1,2	1 550	-20...+75	80 000 / 35 000	135 000	①	
4314 M	140	82	24	12...28	39	5,3	■	2,8	2 300	-20...+75	70 000 / 30 000	117 500	②	
4314 G	170	100	24	12...28	45	5,8	□	4,7	2 800	-20...+75	62 500 / 27 500	105 000	③	
4314	170	100	24	12...28	45	5,8	■	5,0	2 800	-20...+75	62 500 / 27 500	105 000	③	
4314-147	180	106	24	12...28	47	6,1	■	4,7	3 000	-20...+75	57 500 / 25 000	80 000	④	
4314-180	204	120	24	12...26	51	6,4	■	8,5	3 400	-20...+70	45 000 / 22 500	75 000	⑤	
4318 M	140	82	48	36...56	39	5,3	■	3,6	2 300	-20...+75	70 000 / 30 000	117 500	②	
4318	170	100	48	36...53	45	5,8	■	5,1	2 800	-20...+75	62 500 / 27 500	105 000	③	

Subject to alternations

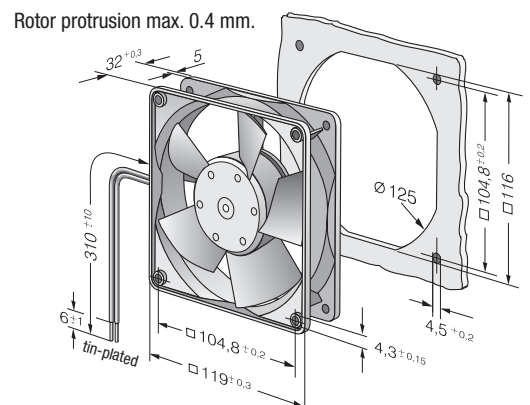
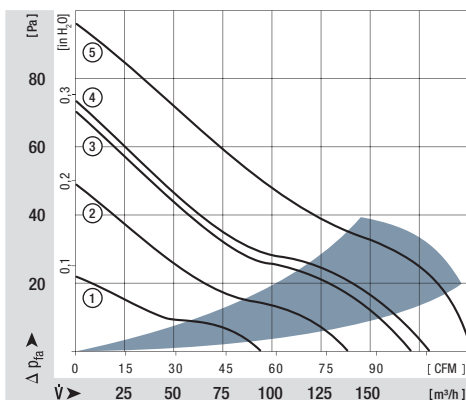

max. 170 m<sup>3</sup>/h

# DC axial fans

Series 4300 VARIOFAN 119 x 119 x 32 mm



- **Material:** Housing: GRP<sup>1)</sup> (PBT)  
Impeller: GRP<sup>1)</sup> (PA)
  - **Direction of air flow:** Exhaust over struts
  - **Direction of rotation:** Clockwise, seen on rotor
  - **Connection:** Via single wires AWG 22, TR 64
  - **Highlights:** Speed automatically adjusted to cooling requirement
  - **Mass:** 220 g
- **Possible special versions:** (See chapter DC fans - specials)
    - Speed signal
    - Go / No-go alarm
    - Alarm with limit speed
    - External temperature sensor
    - Internal temperature sensor
    - PWM control input
    - Analogue control input
    - Protection against moisture

1) Fibreglass-reinforced plastic

Nominal data		Air flow	Air flow	Nominal voltage	Voltage range	Sound pressure level	Sound power level	Sintec sleeve bearings Ball bearings	Input power	Nominal speed	Temperature range	Service life L <sub>10</sub> (40 °C) ebm-papst Standard	Service life L <sub>10</sub> (T <sub>max</sub> ) ebm-papst Standard	Life expectancy L <sub>10</sub> (IPC (40 °C) see page 17	Curve
Type		m <sup>3</sup> /h	CFM	VDC	VDC	dB(A)	Bel(A)	□ / ■	Watts	rpm	°C	Hours	Hours	Hours	
25°C 50°C	4312 MT	65 138	38 81	12	8...15	25 39	3,9 5,3	□ ■	1,1 3,3	1 100 2 300	-20...+65	70 000 / 40 000	117 500		① ②
25°C 50°C	4312 T	85 170	50 100	12	8...13,2	29 45	4,2 5,8	■	1,7 5,0	1 400 2 800	-20...+65	65 000 / 35 000	110 000		③ ④
30°C 50°C	4314 T	85 170	50 100	24	18...32	29 45	4,2 5,8	■	1,6 4,8	1 400 2 800	-20...+65	65 000 / 35 000	110 000		③ ④

Subject to alternations

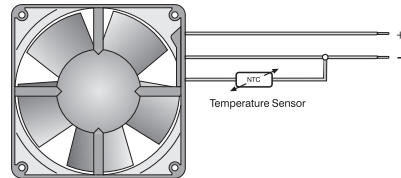
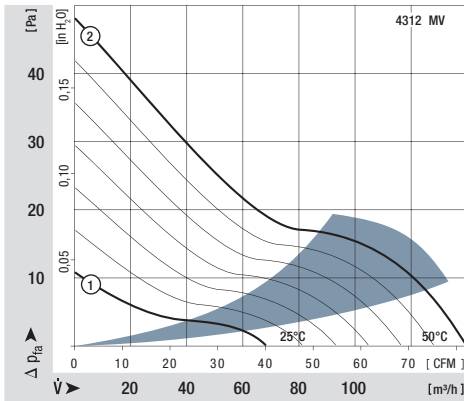

The temperature sensor for controlling the motor speed is not included in delivery. Temperature sensor LZ 370 see accessories.

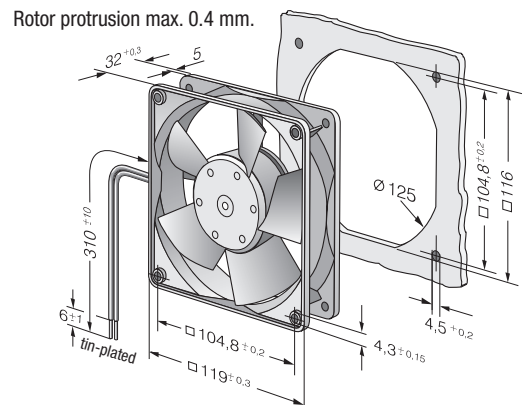
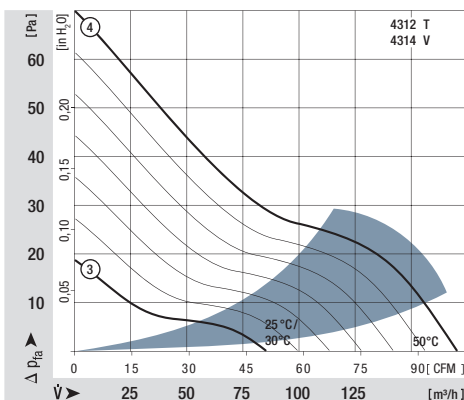



max. 205 m<sup>3</sup>/h

# DC axial fans

Series 4400 119 x 119 x 38 mm



- **Material:** Housing: GRP<sup>1)</sup> (PBT)  
Impeller: GRP<sup>1)</sup> (PA)
- **Direction of air flow:** Exhaust over struts
- **Direction of rotation:** Clockwise, seen on rotor
- **Connection:** Via single wires AWG 24, TR 64
- **Mass:** 270 g

- **Possible special versions:**  
(See chapter DC fans - specials)
  - Speed signal
  - Go / No-go alarm
  - Alarm with limit speed
  - External temperature sensor
  - Internal temperature sensor
  - PWM control input
  - Analogue control input
  - Protection against moisture
  - Type of protection: IP 54

1) Fibreglass-reinforced plastic

Nominal data	Air flow		Nominal voltage	Voltage range	Sound pressure level	Sound power level	Sinter sleeve bearings Ball bearings	Input power	Nominal speed	Temperature range	Service life L <sub>10</sub> (40 °C) ebm-papst Standard	Service life L <sub>10</sub> (T <sub>max</sub> ) ebm-papst Standard	Life expectancy L <sub>10</sub> (PC (40 °C) see page 17	Curve
	m <sup>3</sup> /h	CFM												
4412 L	150	88	12	7...14	37	5,0	■	2,2	2 700	-20...+80	67 500 / 22 500	115 000	③	
4412 ML	168	99	12	7...15	40	5,1	■	3,0	3 000	-20...+80	67 500 / 22 500	115 000	④	
4412 M	184	108	12	7...14	42	5,3	■	3,8	3 300	-20...+75	65 000 / 25 000	110 000	⑤	
4412 N	205	121	12	7...14	46	5,6	■	5,3	3 650	-20...+70	62 500 / 30 000	105 000	⑥	
4414 L3	100	59	24	12...28	26	4,0	■	1,0	1 800	-20...+80	75 500 / 22 500	127 500	①	
4414 LL	124	73	24	12...28	33	4,5	■	1,6	2 250	-20...+80	70 000 / 22 500	117 500	②	
4414 L	150	88	24	18...28	37	5,0	■	2,4	2 700	-20...+80	67 500 / 22 500	115 000	③	
4414 ML	168	99	24	12...28	40	5,1	■	3,2	3 000	-20...+80	67 500 / 22 500	115 000	④	
4414 M	184	108	24	18...28	42	5,3	■	4,1	3 300	-20...+75	65 000 / 25 000	110 000	⑤	
4414 N	205	121	24	18...28	46	5,6	■	5,4	3 650	-20...+70	62 500 / 30 000	105 000	⑥	
4418 L	150	88	48	36...60	37	5,0	■	2,5	2 700	-20...+75	67 500 / 27 500	115 000	③	
4418 ML	168	99	48	36...60	40	5,1	■	3,2	3 000	-20...+75	67 500 / 27 500	115 000	④	
4418 M	184	108	48	36...60	42	5,3	■	4,2	3 300	-20...+70	65 000 / 32 500	110 000	⑤	
4418 N	205	121	48	36...60	46	5,6	■	5,4	3 650	-20...+70	62 500 / 30 000	105 000	⑥	

Subject to alternations

Further variants can be found on page 59.

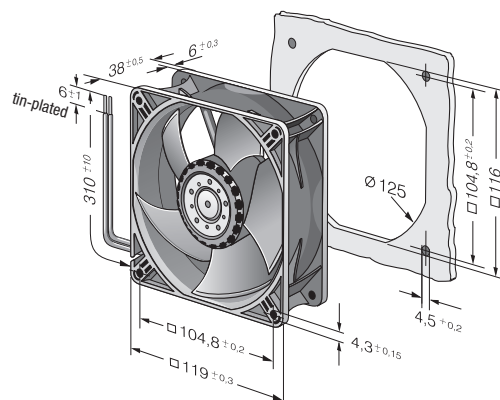
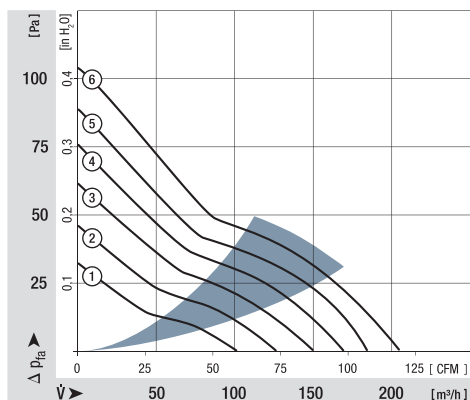



max. 285 m<sup>3</sup>/h

# DC axial fans

Series 4400 119 x 119 x 38 mm



- **Material:** Housing: GRP<sup>1)</sup> (PBT)  
Impeller: GRP<sup>1)</sup> (PA)
  - **Direction of air flow:** Exhaust over struts
  - **Direction of rotation:** Clockwise, seen on rotor
  - **Connection:** Via single wires AWG 24, TR 64
  - **Mass:** 270 g
- **Possible special versions:**  
(See chapter DC fans - specials)
    - Speed signal
    - Go / No-go alarm
    - Alarm with limit speed
    - External temperature sensor
    - Internal temperature sensor
    - PWM control input
    - Analogue control input
    - Protection against moisture
    - Type of protection: IP 54

1) Fibreglass-reinforced plastic

Nominal data	Air flow	Air flow	Nominal voltage	Voltage range	Sound pressure level	Sound power level	Sinter sleeve bearings Ball bearings	Input power	Nominal speed	Temperature range	Service life L <sub>10</sub> (40 °C) ebm-papst Standard	Service life L <sub>10</sub> (T <sub>max</sub> ) ebm-papst Standard	Life expectancy L <sub>10</sub> (IPC (40 °C) see page 17	Curve
Type	m <sup>3</sup> /h	CFM	VDC	VDC	dB(A)	Bel(A)	■ / ■	Watts	rpm	°C	Hours	Hours	Hours	① / ②
4412 H	240	141	12	7...14	50	6,0	■	8,6	4 300	-20...+70	57 500 / 27 500	92 500	92 500	①
4412/2 HHP	285	168	12	7...14,5	55	6,4	■	13,0	5 000	-20...+70	50 000 / 25 000	85 000	85 000	②
4414 H	240	141	24	18...28	50	6,0	■	8,6	4 300	-20...+70	57 500 / 27 500	92 500	92 500	①
4414 HH	285	165	24	16...28	55	6,4	■	14,0	5 000	-20...+70	50 000 / 25 000	85 000	85 000	②
4414/2 HHP	285	168	24	18...28	55	6,4	■	12,0	5 000	-20...+70	50 000 / 25 000	85 000	85 000	②
4418 H	240	141	48	36...60	50	6,0	■	8,6	4 300	-20...+70	57 500 / 27 500	92 500	92 500	①
4418/2 HHP	285	168	48	36...60	55	6,4	■	13,0	5 000	-20...+70	50 000 / 25 000	85 000	85 000	②

Subject to alternations

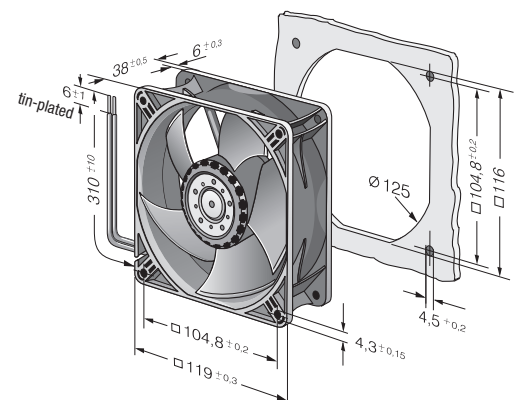
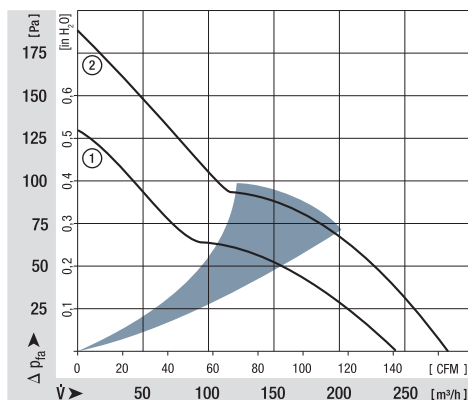

max. 237 m<sup>3</sup>/h

# DC axial fans

Series 4100 N 119 x 119 x 38 mm



- **Material:** Housing: Die-cast aluminium  
Impeller: GRP<sup>1)</sup> (PA)
- **Direction of air flow:** Intake over struts
- **Direction of rotation:** Clockwise, seen on rotor
- **Connection:** On flat connectors, 2.8 x 0.5 mm  
Also available with wires as an option
- **Highlights:** Housing with grounding lug for screw M4 x 8 (Torx)
- **Mass:** 390 g
- **Possible special versions:** (See chapter DC fans - specials)
  - Speed signal
  - Go / No-go alarm
  - Alarm with limit speed
  - External temperature sensor
  - Internal temperature sensor
  - PWM control input
  - Analogue control input
  - Protection against moisture
  - Protection against salt fog
  - Type of protection: IP 54 / IP 68

1) Fibreglass-reinforced plastic

Nominal data	Air flow		Nominal voltage	Voltage range	Sound pressure level	Sound power level	Sintec sleeve bearings Ball bearings	Input power	Nominal speed	Temperature range	Service life L <sub>10</sub> (40 °C) ebm-papst Standard	Service life L <sub>10</sub> (T <sub>max</sub> ) ebm-papst Standard	Life expectancy L <sub>10</sub> IPC (40 °C) see page 17	Curve
	m <sup>3</sup> /h	CFM												
4182 NGX	160	94	12	6...15	44	5,3	□	3,7	2 800	-20...+75	85 000 / 37 500	142 500	①	
4182 NX	180	106	12	6...15	49	5,7	■	4,9	3 200	-30...+75	85 000 / 37 500	142 500	②	
4182 NXH	237	140	12	7...14	57	6,5	■	11,0	4 400	-30...+55	70 000 / 50 000	117 500	③	
4184 NGX	160	94	24	12...31,5	44	5,3	□	3,3	2 800	-20...+75	85 000 / 37 500	142 500	①	
4184 NXM	160	94	24	12...31,5	44	5,3	■	3,2	2 800	-30...+75	85 000 / 37 500	142 500	①	
4184 NX	180	106	24	12...31,5	49	5,7	■	4,9	3 200	-30...+70	85 000 / 42 500	142 500	②	
4184 NXH	237	140	24	12...28	57	6,5	■	11,0	4 400	-30...+70	70 000 / 35 000	117 500	③	
4188 NGX	160	94	48	36...60	44	5,3	□	3,6	2 800	-20...+75	85 000 / 37 500	142 500	①	
4188 NXM	160	94	48	36...60	44	5,3	■	3,5	2 800	-30...+75	85 000 / 37 500	142 500	①	

Subject to alternations

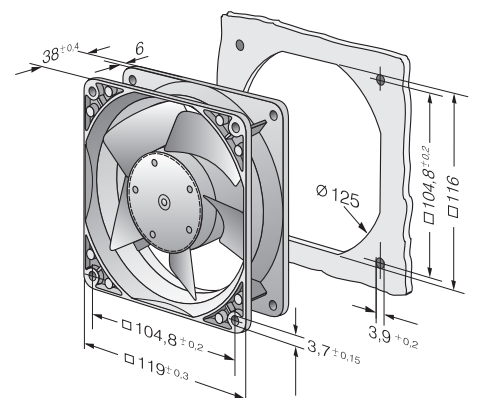
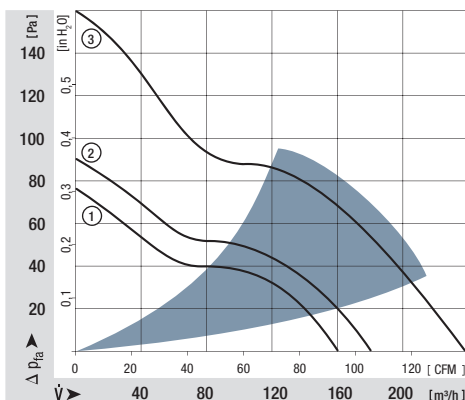

max. 440 m<sup>3</sup>/h

# DC axial fans

Series 4100 N High Performance 119 x 119 x 38 mm



- **Material:** Housing: Die-cast aluminium  
Impeller: GRP<sup>1)</sup> (PA)
  - **Direction of air flow:** Intake over struts
  - **Direction of rotation:** Clockwise, seen on rotor
  - **Connection:** Via single wires AWG 22 UL 1007, TR 64
  - **Highlights:** Housing with grounding lug for screw M4 x 8 (Torx)
  - **Mass:** 390 g
- **Possible special versions:** (See chapter DC fans - specials)
    - Speed signal
    - Go / No-go alarm
    - Alarm with limit speed
    - External temperature sensor
    - Internal temperature sensor
    - PWM control input
    - Analogue control input
    - Protection against moisture
    - Protection against salt fog
    - Type of protection: IP 54 / IP 68

1) Fibreglass-reinforced plastic

Nominal data	Air flow		Nominal voltage	Voltage range	Sound pressure level	Sound power level	Sinter sleeve bearings Ball bearings	Input power*	Nominal speed	Temperature range	Service life L <sub>10</sub> (40 °C) ebm-papst Standard	Service life L <sub>10</sub> (T <sub>max</sub> ) ebm-papst Standard	Life expectancy L <sub>10</sub> (IPC (40 °C) see page 17	Curve
	m <sup>3</sup> /h	CFM												
4112 NHH	260	153	12	9...15	60	6,8	■	13,3	5 000	-20...+65	70 000 / 55 000	117 500	①	
4112 NH3	310	182	12	9...15	65	7,2	■	21,6	6 000	-20...+65	65 000 / 37 500	110 000	②	
4112 NH4	355	209	12	9...14	67	7,4	■	32,0	6 800	-20...+65	62 500 / 35 000	105 000	③	
4114 NHH	260	153	24	16...30	60	6,8	■	12,4	5 000	-20...+65	70 000 / 52 500	117 500	①	
4114 NH3	310	182	24	16...30	65	7,2	■	19,5	6 000	-20...+65	65 000 / 37 500	110 000	②	
4114 NH4	355	209	24	16...30	67	7,4	■	30,0	6 800	-20...+65	62 500 / 35 000	105 000	③	
4114 NH5 <i>S-Force</i>	390	230	24	16...30	70	7,6	■	45,0*	7 500	-20...+65	62 500 / 35 000	105 000	④	
4114 NH6 <i>S-Force</i>	440	259	24	16...30	73	8,1	■	65,0*	8 400	-20...+65	60 000 / 32 500	102 500	⑤	
4118 NHH	260	153	48	36...60	60	6,8	■	12,0	5 000	-20...+65	70 000 / 52 500	117 500	①	
4118 NH3	310	182	48	36...60	65	7,2	■	20,0	6 000	-20...+65	65 000 / 37 500	110 000	②	
4118 NH4	355	209	48	36...60	67	7,4	■	28,0	6 800	-20...+65	62 500 / 35 000	105 000	③	
4118 NH5 <i>S-Force</i>	390	230	48	36...60	70	7,6	■	45,0*	7 500	-20...+65	62 500 / 35 000	105 000	④	
4118 NH6 <i>S-Force</i>	440	259	48	36...60	73	8,1	■	62,0*	8 400	-20...+65	60 000 / 32 500	102 500	⑤	

Subject to alternations

\* Input power at free air flow, these values can be significantly higher in the operating point.

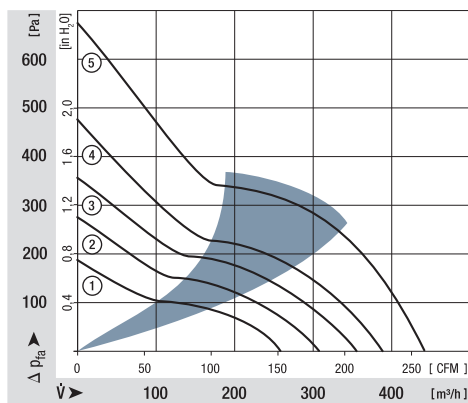

\* Input power - in operation

Fan type	optimum operating range (W)
4114 NH5	55
4114 NH6	95
4118 NH5	55
4118 NH6	95

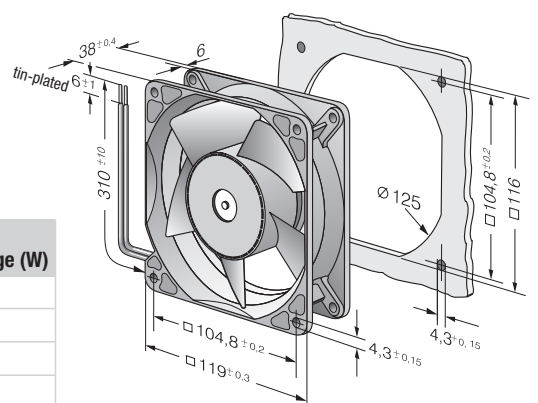

max. 570 m<sup>3</sup>/h  
**S-Force**

## DC axial fans

Series 4100 N High Performance 119 x 119 x 38 mm



- **Material:** Housing: Die-cast aluminium  
Impeller: GRP<sup>1)</sup> (PA)
- **Direction of air flow:** Intake over struts
- **Direction of rotation:** Clockwise, seen on rotor
- **Connection:** Via single wires AWG 18, 20 or AWG 22, TR 64, speed signal and control input AWG 22
- **Highlights:** 3-phase fan drive with very smooth running and high efficiency  
Housing with grounding lug for screw M4 x 8 (Torx)
- **Mass:** 425 g
- **Possible special versions:** (See chapter DC fans - specials)
  - Speed signal
  - Go / No-go alarm
  - Alarm with limit speed
  - External temperature sensor
  - Internal temperature sensor
  - PWM control input
  - Analogue control input
  - Protection against moisture
  - Protection against salt fog

1) Fibreglass-reinforced plastic

Nominal data	Air flow	Air flow	Nominal voltage	Voltage range	Sound pressure level	Sound power level	Sintec sleeve bearings Ball bearings	Input power**	Nominal speed	Temperature range	Service life L <sub>10</sub> (40 °C) ebm-papst Standard	Service life L <sub>10</sub> (T <sub>max</sub> ) ebm-papst Standard	Life expectancy L <sub>10</sub> IPC (40 °C) see page 17	Curve
Type	m <sup>3</sup> /h	CFM	VDC	VDC	dB(A)	Bel(A)	□/■	Watts	rpm	°C	Hours	Hours	Hours	Curve
4114 N/2H7P	500	294	24	16...30	76	8,5	■	90	9 500	-20...+75	57 500 / 25 000	97 500	97 500	①
4114 N/2H8P	570	336	24	16...30	78	8,9	■	120	11 000	-20...+75	55 000 / 22 500	92 500	92 500	②
4118 N/2H7P	500	294	48	36...60*	76	8,5	■	90	9 500	-20...+75	57 500 / 25 000	97 500	97 500	①
4118 N/2H8P	570	336	48	36...60*	78	8,9	■	120	11 000	-20...+75	55 000 / 22 500	92 500	92 500	②

Subject to alternations

\* 36...72 VDC on request.

Speed control range from 500 rpm up to maximum nominal speed. Stationary at 0 % PWM, maximum speed at sensor break.

To attain the specified service life, an external capacitor must be wired between the plus and minus strands.

Please note the wiring suggestion on page 16.

\*\* Input power at free air flow, these values can be significantly higher in the operating point.

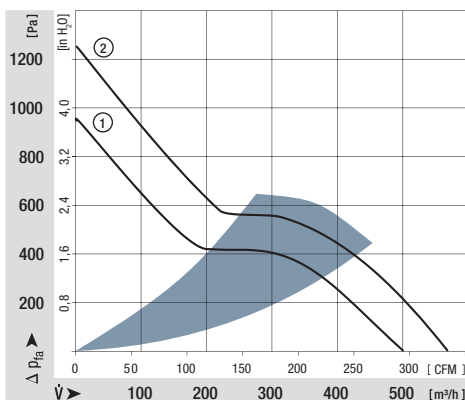

\*\* Input power - in operation

Fan type	optimum operating range (W)
4114 NH7P	100
4114 NH8P	160
4118 NH7P	100
4118 NH8P	160

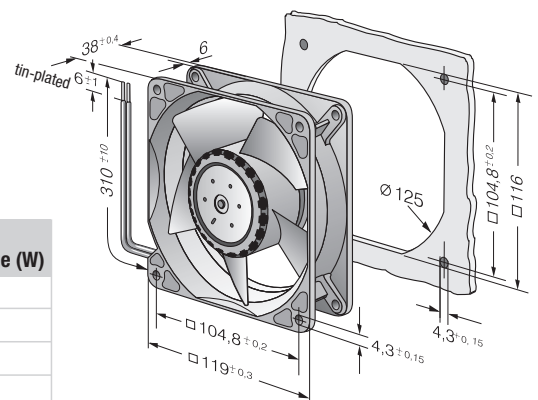

max. 280 m<sup>3</sup>/h

# DC diagonal fans

Series DV 4100 119 x 119 x 38 mm



- **Material:** Housing: GRP<sup>1)</sup> (PBT)  
Available in Die-cast aluminium  
Impeller: GRP<sup>1)</sup> (PA)
  - **Direction of air flow:** Exhaust over struts
  - **Direction of rotation:** Counter-clockwise, seen on rotor
  - **Connection:** Via single wires AWG 22, TR 64
  - **Highlights:** Housing with grounding lug for screw M4 x 8 (Torx)
  - **Mass:** 375 g  
(with metal housing: 455 g)
- **Possible special versions:** (See chapter DC fans - specials)
    - Speed signal
    - Go / No-go alarm
    - Alarm with limit speed
    - External temperature sensor
    - Internal temperature sensor
    - PWM control input
    - Analogue control input
    - Protection against moisture
    - Protection against salt fog
    - Type of protection: IP 54 / IP 68

1) Fibreglass-reinforced plastic

Nominal data	Air flow		Nominal voltage	Voltage range	Sound pressure level	Sound power level	Sinter sleeve bearings Ball bearings	Input power*	Nominal speed	Temperature range	Service life L <sub>10</sub> (40 °C) ebm-papst Standard	Service life L <sub>10</sub> (T <sub>max</sub> ) ebm-papst Standard	Life expectancy L <sub>10</sub> (IPC (40 °C) see page 17	Curve
	m <sup>3</sup> /h	CFM												
DV 4112 N	280	165	12	9...15	61	6,9	■	21,0	6 000	-20...+65	70 000 / 40 000	117 500	①	
DV 4114 N	280	165	24	16...30	61	6,9	■	20,5	6 000	-20...+65	70 000 / 40 000	117 500	①	
DV 4118 N	280	165	48	36...60	61	6,9	■	20,0	6 000	-20...+65	70 000 / 40 000	117 500	①	

Subject to alternations

\* Input power at free air flow, these values can be significantly higher in the operating point.

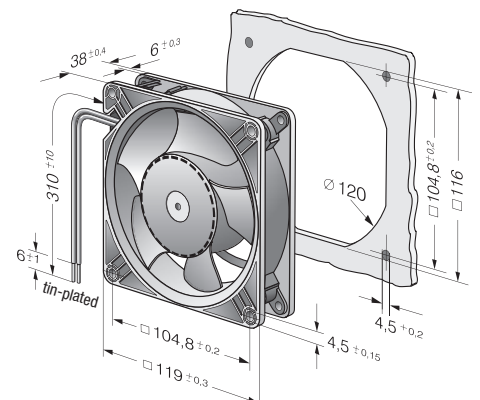
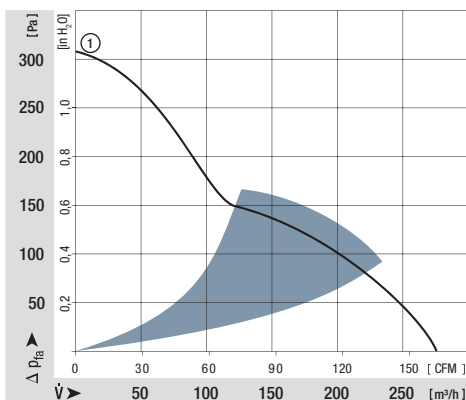



max. 340 m<sup>3</sup>/h

# DC axial fans

Series 5200 N 127 x 127 x 38 mm



- **Material:** Housing: GRP<sup>1)</sup> (PBT)  
Impeller: GRP<sup>1)</sup> (PA)
  - **Direction of air flow:** Exhaust over struts
  - **Direction of rotation:** Counter-clockwise, seen on rotor
  - **Connection:** Via single wires AWG 22, TR 64
  - **Mass:** 310 g
- **Possible special versions:**  
(See chapter DC fans - specials)
    - Speed signal
    - Go / No-go alarm
    - Alarm with limit speed
    - External temperature sensor
    - Internal temperature sensor
    - PWM control input
    - Analogue control input
    - Protection against moisture
    - Protection against salt fog
    - Type of protection: IP 54 / IP 68

1) Fibreglass-reinforced plastic

Nominal data	Air flow		Nominal voltage	Voltage range	Sound pressure level	Sound power level	Sinter sleeve bearings Ball bearings	Input power**	Nominal speed	Temperature range	Service life L <sub>10</sub> (40 °C) ebm-papst Standard	Service life L <sub>10</sub> (T <sub>max</sub> ) ebm-papst Standard	Life expectancy L <sub>10</sub> IPC (40 °C) see page 17	Curve
	m <sup>3</sup> /h	CFM												
5212 NM	187	110	12	7...14,5	43	5,3	■	4,1	2 750	-20...+75	62 500 / 27 500	105 000	①	
5212 NN	216	127	12	7...14	46	5,6	■	6,2	3 150	-20...+70	57 500 / 25 000	97 500	②	
5212 NH	252	148	12	7...14	51	6,0	■	9,8	3 650	-20...+70	45 000 / 22 500	75 000	③	
5212 NHH*	340	200	12	9...15	58	6,6	■	19,0	4 900	-20...+65	45 000 / 25 000	75 000	④	
5214 NM	187	110	24	12...28	43	5,3	■	4,6	2 750	-20...+75	62 500 / 27 500	105 000	①	
5214 NN	216	127	24	12...28	46	5,6	■	6,0	3 150	-20...+75	57 500 / 25 000	97 500	②	
5214 NH	252	148	24	12...28	51	6,0	■	9,8	3 650	-20...+70	45 000 / 22 500	75 000	③	
5214 NHH*	340	200	24	16...30	58	6,6	■	17,5	4 900	-20...+65	45 000 / 25 000	75 000	④	
5218 NM	187	110	48	36...56	43	5,3	■	4,5	2 750	-20...+75	62 500 / 27 500	105 000	①	
5218 NN	216	127	48	36...56	46	5,6	■	6,2	3 150	-20...+70	57 500 / 32 500	97 500	②	
5218 NH	252	148	48	36...56	51	6,0	■	9,6	3 650	-20...+55	45 000 / 32 500	75 000	③	
5218 NHH*	340	200	48	36...60	58	6,6	■	18,0	4 900	-20...+65	45 000 / 25 000	75 000	④	

Subject to alternations

\*\* Input power at free air flow, these values can be significantly higher in the operating point.

\*Models NHH: Fan housing with moulded-in spacers.

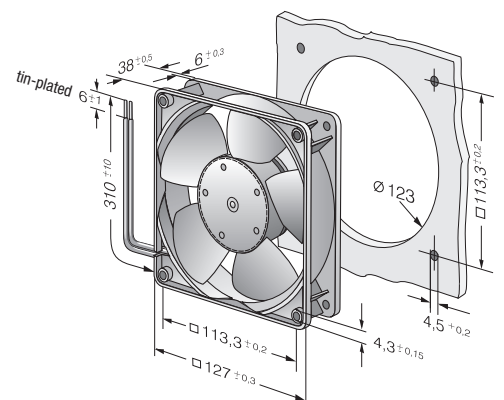
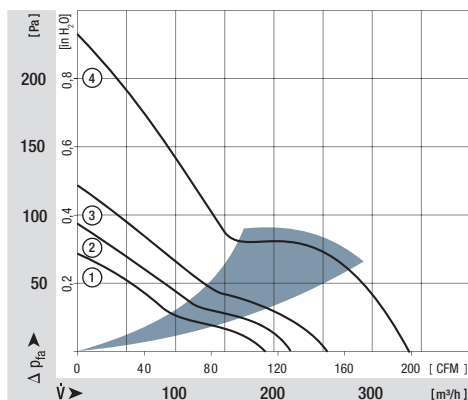
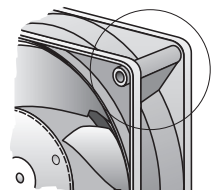



max. 320 m<sup>3</sup>/h

# DC diagonal fans

Series DV 5200 127 x 127 x 38 mm



- **Material:** Housing: GRP<sup>1)</sup> (PBT)  
Available in Die-cast aluminium  
Metal flange  
Impeller: GRP<sup>1)</sup> (PA)
  - **Direction of air flow:** Exhaust over struts
  - **Direction of rotation:** Counter-clockwise, seen on rotor
  - **Connection:** Via single wires AWG 22, TR 64
  - **Highlights:** Housing with grounding lug for screw M4 x 8 (Torx)
  - **Mass:** 415 g (with metal housing: 490 g)
- **Possible special versions:** (See chapter DC fans - specials)
    - Speed signal
    - Go / No-go alarm
    - Alarm with limit speed
    - External temperature sensor
    - Internal temperature sensor
    - PWM control input
    - Analogue control input
    - Protection against moisture
    - Protection against salt fog
    - Type of protection: IP 54 / IP 68

1) Fibreglass-reinforced plastic

Nominal data	Air flow	Air flow	Nominal voltage	Voltage range	Sound pressure level	Sound power level	Sintec sleeve bearings Ball bearings	Input power*	Nominal speed	Temperature range	Service life L <sub>10</sub> (40 °C) ebm-papst Standard	Service life L <sub>10</sub> (T <sub>max</sub> ) ebm-papst Standard	Life expectancy L <sub>10</sub> (IPC (40 °C) see page 17	Curve
Type	m <sup>3</sup> /h	CFM	VDC	VDC	dB(A)	Bel(A)	■/■	Watts	rpm	°C	Hours	Hours	Hours	Curve
DV 5212 N	270	159	12	9...15	56	6,4	■	21,0	5 000	-20...+65	70 000 / 40 000	117 500	117 500	①
DV 5214 N	270	159	24	16...30	56	6,4	■	20,4	5 000	-20...+65	70 000 / 40 000	117 500	117 500	①
DV 5218 N	270	159	48	36...60	56	6,4	■	18,5	5 000	-20...+65	70 000 / 40 000	117 500	117 500	①
Model comes standard with speed signal and PWM control input. Other versions by request.														
DV 5214/2 HP	320	188	24	16...30	62	7,2	■	38,5	6 000	-20...+65	62 500 / 35 000	105 000	105 000	②

Subject to alternations

Speed control range from 1000 rpm up to maximum nominal speed. Stationary at 0 % PWM, maximum speed at sensor break.

\* Input power at free air flow, these values can be significantly higher in the operating point.

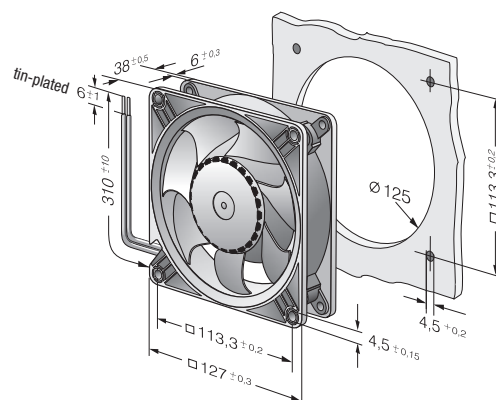
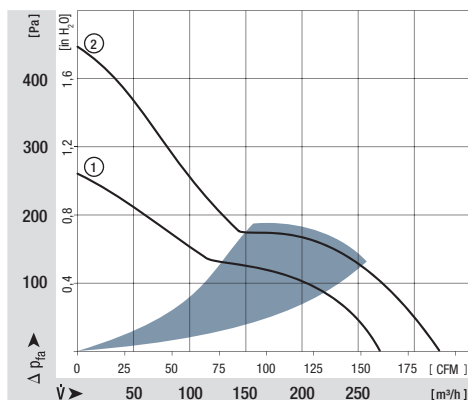

max. 260 m<sup>3</sup>/h

## DC axial fans

Series 5100 N 135 x 135 x 38 mm



- **Material:** Housing: Die-cast aluminium  
Impeller: Painted sheet steel
  - **Direction of air flow:** Exhaust over struts
  - **Direction of rotation:** Counter-clockwise, seen on rotor
  - **Connection:** Via single wires AWG 22, TR 64
  - **Highlights:** Housing with grounding lug for screw M4 x 8 (Torx)  
48 V version incl. screws
  - **Mass:** 650 g
- **Possible special versions:** (See chapter DC fans - specials)
    - Speed signal
    - Go / No-go alarm
    - Alarm with limit speed
    - External temperature sensor
    - Internal temperature sensor
    - PWM control input
    - Analogue control input
    - Protection against moisture
    - Protection against salt fog
    - Type of protection: IP 54

1) Fibreglass-reinforced plastic

Nominal data	Air flow	Air flow	Nominal voltage	Voltage range	Sound pressure level	Sound power level	Sintec sleeve bearings Ball bearings	Input power*	Nominal speed	Temperature range	Service life L <sub>10</sub> (40 °C) ebm-papst Standard	Service life L <sub>10</sub> (T <sub>max</sub> ) ebm-papst Standard	Life expectancy L <sub>10</sub> IPC (40 °C) see page 17	Curve
Type	m <sup>3</sup> /h	CFM	VDC	VDC	dB(A)	Bel(A)	□/■	Watts	rpm	°C	Hours	Hours		
5112 N	260	153	12	6...15	48	6,1	■	9,5	2 900	-25...+72	80 000 / 37 500	135 000	①	
5114 N	260	153	24	12...30	48	6,1	■	9,5	2 900	-25...+72	80 000 / 37 500	135 000	①	
5118 N	260	153	48	24...60	48	6,1	■	9,5	2 900	-25...+72	80 000 / 37 500	135 000	①	

Subject to alternations

\* Input power at free air flow, these values can be significantly higher in the operating point.

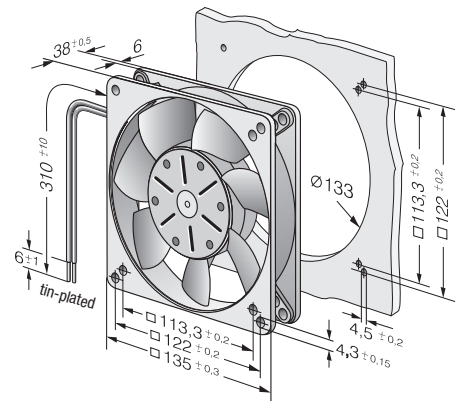
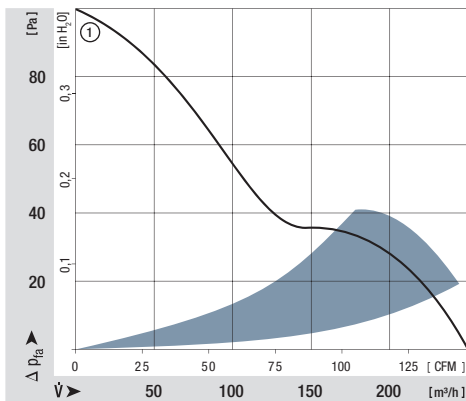

max. 340 m<sup>3</sup>/h  
**S-Force**

## DC axial fans

Series 5300 140 x 140 x 51 mm



- **Material:** Housing: Die-cast aluminium  
Impeller: GRP<sup>1)</sup> (PA)
  - **Direction of air flow:** Intake over struts
  - **Direction of rotation:** Counter-clockwise, seen on rotor
  - **Connection:** Via single wires AWG 22, TR 64
  - **Highlights:** Housing with grounding lug for screw M4 x 8 (Torx)
  - **Mass:** 900 g
- **Possible special versions:** (See chapter DC fans - specials)
    - Speed signal
    - Go / No-go alarm
    - Alarm with limit speed
    - External temperature sensor
    - Internal temperature sensor
    - PWM control input
    - Analogue control input
    - Protection against moisture
    - Protection against salt fog
    - Type of protection: IP 54

1) Fibreglass-reinforced plastic

Nominal data	Air flow		Nominal voltage	Voltage range	Sound pressure level	Sound power level	Sinter sleeve bearings Ball bearings	Input power*	Nominal speed	Temperature range	Service life L <sub>10</sub> (40 °C) ebm-papst Standard	Service life L <sub>10</sub> (T <sub>max</sub> ) ebm-papst Standard	Life expectancy L <sub>10</sub> (IPC (40 °C) see page 17	Curve
	m <sup>3</sup> /h	CFM												
5314/2 HP	340	200	24	16...28	64	7,2	■	28,4	5 000	-20...+65	77 500 / 40 000	130 000	①	
5318/2 HP	340	200	48	36...72	64	7,2	■	27	5 000	-20...+65	77 500 / 40 000	130 000	①	

Subject to alternations

Speed control range from 700 rpm up to maximum nominal speed. Stationary at 0 % PWM, maximum speed at sensor break.  
\* Input power at free air flow, these values can be significantly higher in the operating point.

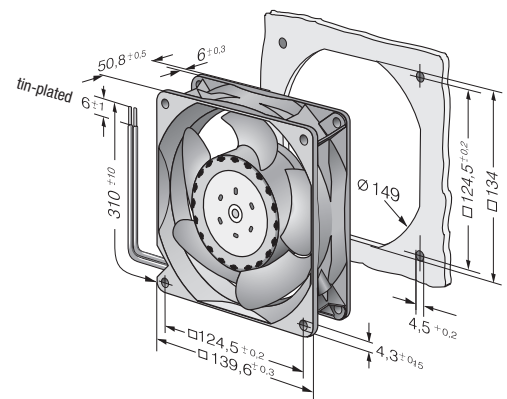
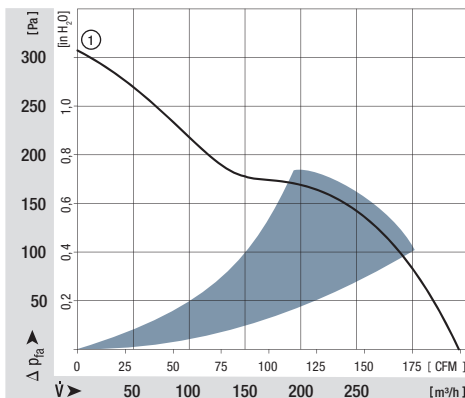

max. 670 m<sup>3</sup>/h  
**S-Force**

## DC axial fans

Series 5300 TD 140 x 140 x 51 mm



- **Material:** Housing: Die-cast aluminium  
Impeller: GRP<sup>1)</sup> (PA)
  - **Direction of air flow:** Intake over struts
  - **Direction of rotation:** Counter-clockwise, seen on rotor
  - **Connection:** Via single wires AWG 20 and AWG 22, TR 64
  - **Highlights:** 3-phase fan drive with very smooth running and high efficiency
  - **Mass:** 900 g
- **Possible special versions:** (See chapter DC fans - specials)
    - Speed signal
    - Go / No-go alarm
    - Alarm with limit speed
    - External temperature sensor
    - Internal temperature sensor
    - PWM control input
    - Analogue control input
    - Multi-option control input
    - Protection against moisture
    - Protection against salt fog
    - Type of protection: IP 54 / IP 68

1) Fibreglass-reinforced plastic

Nominal data	Air flow		Nominal voltage	Voltage range	Sound pressure level	Sound power level	Sintec sleeve bearings Ball bearings	Input power*	Nominal speed	Temperature range	Service life L <sub>10</sub> (40 °C) ebm-papst Standard	Service life L <sub>10</sub> (T <sub>max</sub> ) ebm-papst Standard	Life expectancy L <sub>10</sub> IPC (40 °C) see page 17	Curve
	m <sup>3</sup> /h	CFM												
5312/2 TDHP	410	241	12	8...16	70	7,7	■	43	6 000	-20...+70	70 000 / 35 000	117 500	①	
5314/2 TDHP	410	241	24	16...36	70	7,7	■	42	6 000	-20...+70	70 000 / 35 000	117 500	①	
5314/2 TDHHP	490	288	24	16...36	75	8,1	■	67	7 000	-20...+70	62 500 / 30 000	105 000	②	
5318/2 TDHP	410	241	48	36...72	70	7,7	■	42	6 000	-20...+70	70 000 / 35 000	117 500	①	
5318/2 TDHHP	490	288	48	36...72	75	8,1	■	66	7 000	-20...+70	62 500 / 30 000	105 000	②	
5318/2 TDH4P	670	394	48	36...72	79	8,8	■	149	9 200	-20...+65	57 500 / 32 500	97 500	③	

Subject to alternations

Speed control range from 1000 rpm up to maximum nominal speed. Stationary at 0 % PWM, maximum speed at sensor break.

\* Input power at free air flow, these values can be significantly higher in the operating point.

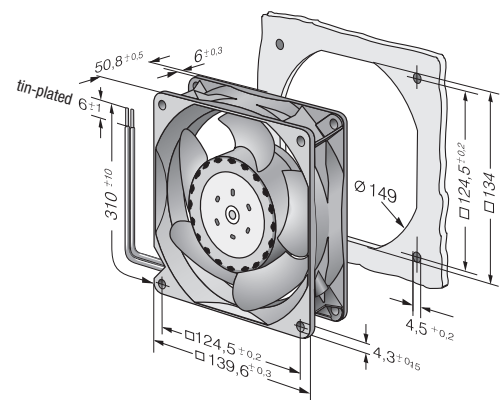
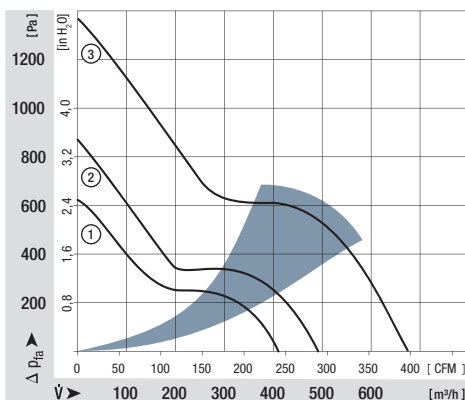

max. 360 m<sup>3</sup>/h

# DC axial fans

Series 7100 N Ø 150 x 38 mm



- **Material:** Housing: Die-cast aluminium  
Impeller: Painted sheet steel
  - **Direction of air flow:** Exhaust over struts
  - **Direction of rotation:** Counter-clockwise, seen on rotor
  - **Connection:** Via single wires AWG 22, TR 64
  - **Highlights:** Housing with grounding lug for screw M4 x 8 (Torx)
  - **Mass:** 620 g
- **Possible special versions:** (See chapter DC fans - specials)
    - Speed signal
    - Go / No-go alarm
    - Alarm with limit speed
    - External temperature sensor
    - Internal temperature sensor
    - PWM control input
    - Analogue control input
    - Protection against moisture
    - Protection against salt fog
    - Type of protection: IP 54 / IP 68

Nominal data		Air flow	Air flow	Nominal voltage	Voltage range	Sound pressure level	Sound power level	Sinter sleeve bearings Ball bearings	Input power*	Nominal speed	Temperature range	Service life L <sub>10</sub> (40 °C) ebm-papst Standard	Service life L <sub>10</sub> (T <sub>max</sub> ) ebm-papst Standard	Life expectancy L <sub>10</sub> (IPC (40 °C) see page 17	Curve
Type		m <sup>3</sup> /h	CFM	VDC	VDC	dB(A)	Bel(A)	■ / ■	Watts	rpm	°C	Hours	Hours	Hours	
7112 N		308	181	12	6...15	53	6,2	■	12,0	2 850	-25...+72	80 000 / 37 500	135 000	135 000	①
7114 N		308	181	24	12...30	53	6,2	■	12,0	2 850	-25...+72	80 000 / 37 500	135 000	135 000	①
7114 NH		360	212	24	12...26,5	58	6,7	■	19,0	3 350	-25...+72	75 000 / 35 000	127 500	127 500	②
7118 N		308	181	48	24...60	53	6,2	■	12,0	2 850	-25...+72	80 000 / 37 500	135 000	135 000	①

Subject to alternations

\* Input power at free air flow, these values can be significantly higher in the operating point.

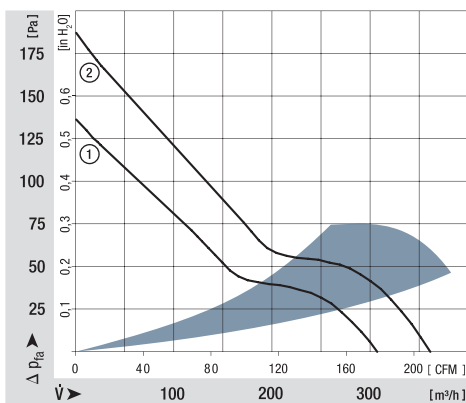

Strand fastened using cable tie;  
cable tie protrudes 1 mm.

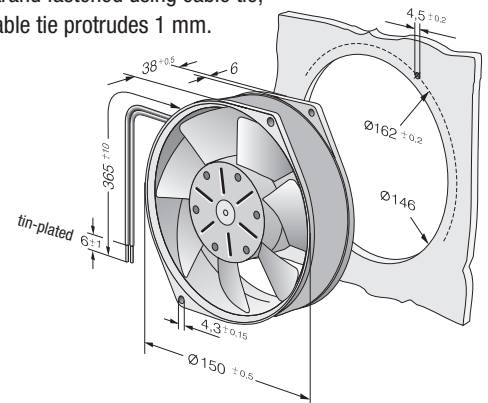

max. 360 m<sup>3</sup>/h

# DC axial fans

Series 7200 N Ø 150 x 55 mm



- **Material:** Housing: Die-cast aluminium  
Impeller: GRP<sup>1)</sup> (PA)
  - **Direction of air flow:** Exhaust over struts
  - **Direction of rotation:** Counter-clockwise, seen on rotor
  - **Connection:** Via single wires AWG 22, TR 64
  - **Highlights:** Housing with grounding lug for screw M4 x 8 (Torx)
  - **Mass:** 725 g
- **Possible special versions:**  
(See chapter DC fans - specials)
    - Speed signal
    - Go / No-go alarm
    - Alarm with limit speed
    - External temperature sensor
    - Internal temperature sensor
    - PWM control input
    - Analogue control input
    - Protection against moisture
    - Protection against salt fog
    - Type of protection: IP 54 / IP 68

1) Fibreglass-reinforced plastic

Nominal data	Air flow		Nominal voltage	Voltage range	Sound pressure level	Sound power level	Sinter sleeve bearings Ball bearings	Input power*	Nominal speed	Temperature range	Service life L <sub>10</sub> (40 °C) ebm-papst Standard	Service life L <sub>10</sub> (T <sub>max</sub> ) ebm-papst Standard	Life expectancy L <sub>10</sub> IPC (40 °C) see page 17	Curve
	m <sup>3</sup> /h	CFM												
7212 N	360	212	12	6...15	53	6,2	■	12,0	3 050	-25...+72	80 000 / 37 500	135 000	①	
7214 N	360	212	24	12...30	53	6,2	■	12,0	3 050	-25...+72	80 000 / 37 500	135 000	①	
7218 N	360	212	48	24...60	53	6,2	■	12,0	3 050	-25...+72	80 000 / 37 500	135 000	①	

Subject to alternations

\* Input power at free air flow, these values can be significantly higher in the operating point.

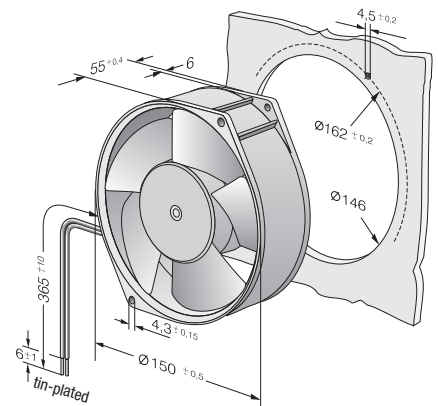
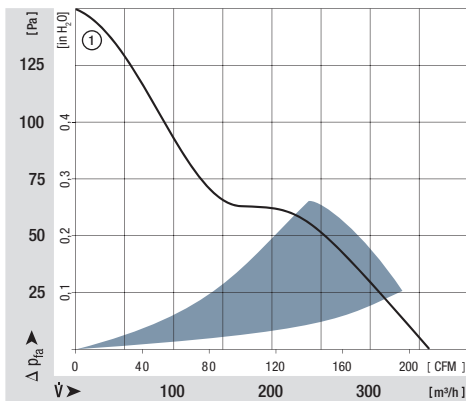



max. 350 m<sup>3</sup>/h

# DC axial fans

Series 6100 N 172 x 160 x 52 mm



- **Material:** Housing: GRP<sup>1)</sup> (PBT)  
Impeller: GRP<sup>1)</sup> (PA)
  - **Direction of air flow:** Exhaust over struts
  - **Direction of rotation:** Counter-clockwise, seen on rotor
  - **Connection:** Via single wires AWG 22, TR 64
  - **Highlights:** Light and compact plastic housing
  - **Mass:** 610 g
- **Possible special versions:** (See chapter DC fans - specials)
    - Speed signal
    - Go / No-go alarm
    - Alarm with limit speed
    - External temperature sensor
    - Internal temperature sensor
    - PWM control input
    - Analogue control input
    - Protection against moisture
    - Type of protection: IP 54

1) Fibreglass-reinforced plastic

Nominal data	Air flow		Nominal voltage	Voltage range	Sound pressure level	Sound power level	Sinter sleeve bearings Ball bearings	Input power*	Nominal speed	Temperature range	Service life L <sub>10</sub> (40 °C) ebm-papst Standard	Service life L <sub>10</sub> (T <sub>max</sub> ) ebm-papst Standard	Life expectancy L <sub>10</sub> (IPC (40 °C) see page 17	Curve
	m <sup>3</sup> /h	CFM												
6112 NM	350	206	12	8...15	49	5,9	■	11	2 850	-20...+70	80 000 / 40 000	135 000	①	
6114 NM	350	206	24	12...32	49	5,9	■	11	2 850	-20...+70	80 000 / 40 000	135 000	①	

Subject to alternations

\* Input power at free air flow, these values can be significantly higher in the operating point.

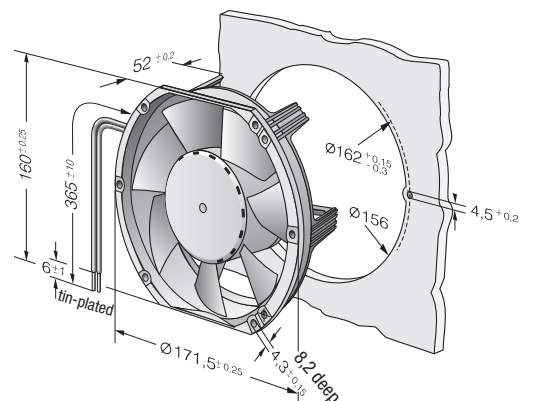
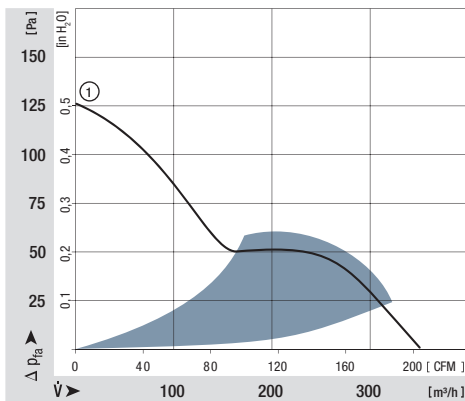

max. 545 m<sup>3</sup>/h  
**S-Force**

## DC axial fans

Series 6300 Ø 172 x 51 mm



- **Material:** Housing: Die-cast aluminium  
Impeller: GRP<sup>1)</sup> (PA)
  - **Direction of air flow:** Exhaust over struts
  - **Direction of rotation:** Counter-clockwise, seen on rotor
  - **Connection:** Via single wires AWG 22, TR 64
  - **Highlights:** Housing with grounding lug for screw M4 x 8 (Torx)
  - **Mass:** 910 g
- **Possible special versions:** (See chapter DC fans - specials)
    - Speed signal
    - Go / No-go alarm
    - Alarm with limit speed
    - External temperature sensor
    - Internal temperature sensor
    - PWM control input
    - Analogue control input
    - Protection against moisture
    - Protection against salt fog
    - Type of protection: IP 54

1) Fibreglass-reinforced plastic

Nominal data	Air flow	Air flow	Nominal voltage	Voltage range	Sound pressure level	Sound power level	Sintec sleeve bearings Ball bearings	Input power*	Nominal speed	Temperature range	Service life L <sub>10</sub> (40 °C) ebm-papst Standard	Service life L <sub>10</sub> (T <sub>max</sub> ) ebm-papst Standard	Life expectancy L <sub>10</sub> IPC (40 °C) see page 17	Curve
Type	m <sup>3</sup> /h	CFM	VDC	VDC	dB(A)	Bel(A)	□/■	Watts	rpm	°C	Hours	Hours	Hours	
6314/2 MP	395	232	24	16...30	51	6,0	■	14	3 700	-20...+75	82 500 / 32 500	140 000	①	
6314/2 NP	470	276	24	16...30	56	6,5	■	23	4 400	-20...+70	80 000 / 40 000	135 000	②	
6314/2 HP	545	320	24	16...30	58	6,9	■	31	5 000	-20...+65	77 500 / 42 500	130 000	③	
6318/2 HP	545	320	48	36...72	58	6,9	■	32	5 000	-20...+65	77 500 / 42 500	130 000	③	

Subject to alternations

Speed control range from 700 rpm up to maximum nominal speed. Stationary at 0 % PWM, maximum speed at sensor break.

\* Input power at free air flow, these values can be significantly higher in the operating point.

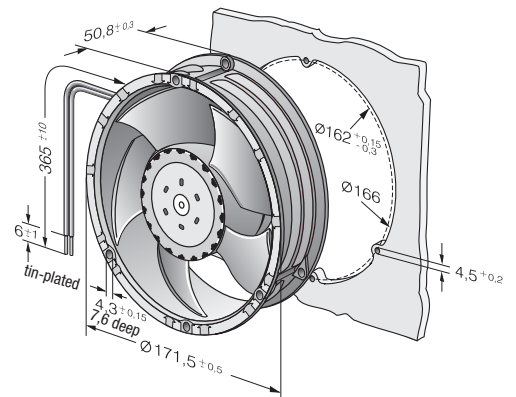
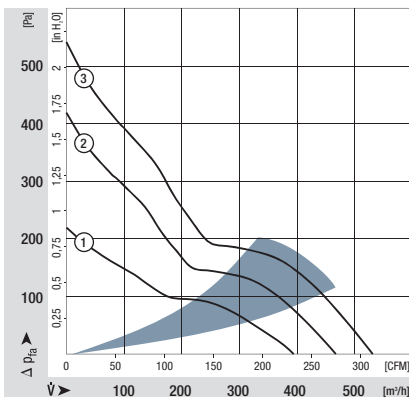

max. 930 m<sup>3</sup>/h  
**S-Force**

## DC axial fans

Series 6300 TD Ø 172 x 51 mm



- **Material:** Housing: Die-cast aluminium  
Impeller: GRP<sup>1)</sup> (PA)
- **Direction of air flow:** Exhaust over struts
- **Direction of rotation:** Counter-clockwise, seen on rotor
- **Connection:** Via single wires AWG 18, 20 or AWG 22, TR 64, speed signal and control input AWG 22
- **Highlights:** 3-phase fan drive with very smooth running and high efficiency. Housing with grounding lug for screw M4 x 8 (Torx) 910 g
- **Mass:** 910 g
- **Possible special versions:** (See chapter DC fans - specials)
  - Speed signal
  - Go / No-go alarm
  - Alarm with limit speed
  - External temperature sensor
  - Internal temperature sensor
  - PWM control input
  - Analogue control input
  - Multi-option control input
  - Protection against moisture
  - Protection against salt fog
  - Type of protection: IP 54

1) Fibreglass-reinforced plastic

Nominal data		Air flow		Nominal voltage	Voltage range	Sound pressure level	Sound power level	Sintec sleeve bearings Ball bearings	Input power*	Nominal speed	Temperature range	Service life L <sub>10</sub> (40 °C) ebm-papst Standard	Service life L <sub>10</sub> (T <sub>max</sub> ) ebm-papst Standard	Life expectancy L <sub>10</sub> (IPC (40 °C) see page 17	Curve
Type	m <sup>3</sup> /h	CFM	VDC	VDC	dB(A)	Bel(A)	■ / ■	Watts	rpm	°C	Hours	Hours	Hours	Curve	
6312/2 TDHP	600	353	12	8...16	60	7,3	■	40	5 500	-20...+70	75 000 / 37 500	127 500	②		
NEW 6314/2 TDHP-298	600	353	24	16...30	60	7,3	■	42	5 500	-20...+65	75 000 / 42 500	127 500	①		
6314/2 TDHP	600	353	24	16...36	60	7,3	■	40	5 500	-20...+75	75 000 / 30 000	127 500	②		
6314/2 TDHHP	710	418	24	16...36	69	7,9	■	67	7 000	-20...+75	62 500 / 25 000	105 000	③		
NEW 6314/2 TDH4P	930	545	24	16...36	75	8,4	■	150	9 200	-20...+75	52 500 / 20 000	87 500	⑤		
NEW 6318/2 TDHP-299	600	353	48	36...60	60	7,3	■	42	5 500	-20...+65	75 000 / 42 500	127 500	①		
6318/2 TDHP	600	353	48	36...72	60	7,3	■	40	5 500	-20...+75	75 000 / 30 000	127 500	②		
6318/2 TDHHP	710	418	48	36...72	69	7,9	■	67	7 000	-20...+75	62 500 / 25 000	105 000	③		
6318/2 TDH4P	930	545	48	36...72	75	8,4	■	150	9 200	-20...+75	52 500 / 20 000	87 500	④		

Subject to alternations

Speed control range from 1000 rpm up to maximum nominal speed. Stationary at 0 % PWM, maximum speed at sensor break.

\* Input power at free air flow, these values can be significantly higher in the operating point.

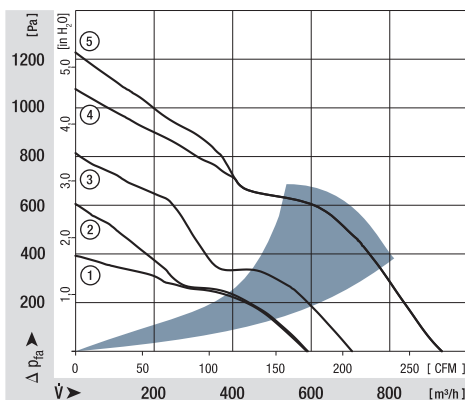

\* Input power - in operation

Fan type	optimum operating range (W)
6318/2 TDHHP	115
6318/2 TDH4P	270

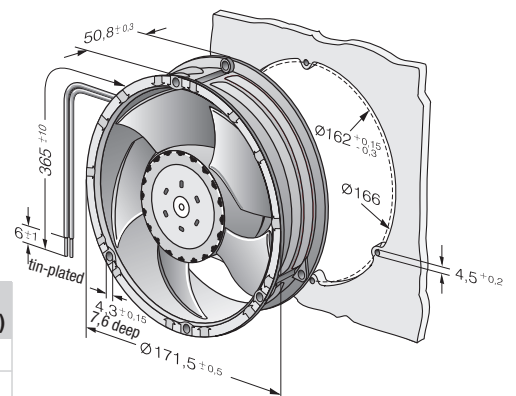

max. 930 m<sup>3</sup>/h  
**S-Force**

## DC axial fans

Series 6300 TD 172 x 160 x 51 mm



- **Material:** Housing: Die-cast aluminium  
Impeller: GRP<sup>1)</sup> (PA)
  - **Direction of air flow:** Exhaust over struts
  - **Direction of rotation:** Counter-clockwise, seen on rotor
  - **Connection:** Via single wires AWG 18, 20 or AWG 22, TR 64, speed signal and control input AWG 22
  - **Highlights:** 3-phase fan drive with very smooth running and high efficiency. Housing with grounding lug for screw M4 x 8 (Torx)
  - **Mass:** 910 g
- **Possible special versions:** (See chapter DC fans - specials)
    - Speed signal
    - Go / No-go alarm
    - Alarm with limit speed
    - External temperature sensor
    - Internal temperature sensor
    - PWM control input
    - Analogue control input
    - Multi-option control input
    - Protection against moisture
    - Protection against salt fog
    - Type of protection: IP 54

1) Fibreglass-reinforced plastic

Nominal data	Air flow		Nominal voltage	Voltage range	Sound pressure level	Sound power level	Sintec sleeve bearings Ball bearings	Input power*	Nominal speed	Temperature range	Service life L <sub>10</sub> (40 °C) ebm-papst Standard	Service life L <sub>10</sub> (T <sub>max</sub> ) ebm-papst Standard	Life expectancy L <sub>10</sub> IPC (40 °C) see page 17	Curve
	m <sup>3</sup> /h	CFM												
6314/2 TDHHP-015	710	418	24	16...36	69	7,9	■	67	7 000	-20...+75	62 500 / 25 000	105 000	①	
6318/2 TDH4P-007	930	546	48	36...72	75	8,4	■	150	9 200	-20...+75	52 500 / 20 000	87 500	②	

Subject to alterations

Speed control range from 1000 rpm up to maximum nominal speed. Stationary at 0 % PWM, maximum speed at sensor break.

\* Input power at free air flow, these values can be significantly higher in the operating point.

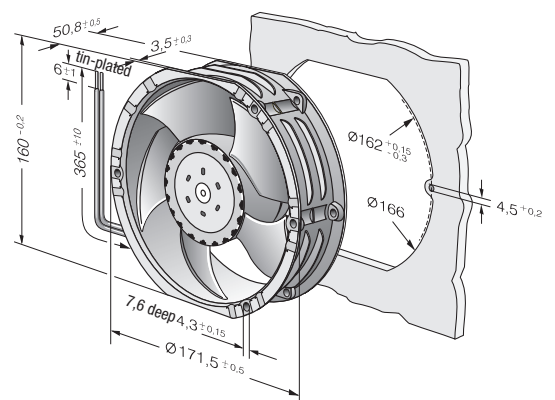
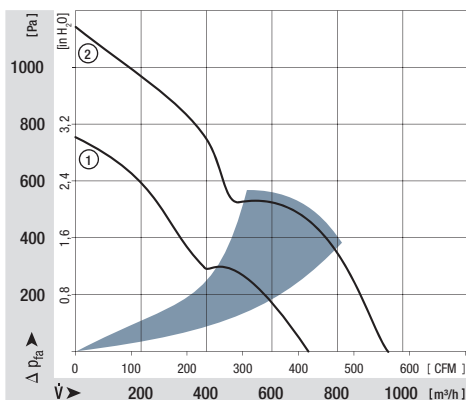

max. 1100 m<sup>3</sup>/h

# DC diagonal fans

Series DV 6300 Ø 172 x 51 mm



- **Material:** Housing: Die-cast aluminium  
Impeller: GRP<sup>1)</sup> (PA)
- **Direction of air flow:** Exhaust over struts
- **Direction of rotation:** Counter-clockwise, seen on rotor
- **Connection:** (+) and GND: AWG 18, UL 1007, TR 64, speed signal and control input AWG 22, UL 1007, TR 64
- **Highlights:** 3-phase fan drive with very smooth running and high efficiency. Housing with grounding lug for screw M4 x 8 (Torx)
- **Mass:** 1050 g
- **Possible special versions:** (See chapter DC fans - specials)
  - Speed signal
  - Go / No-go alarm
  - Alarm with limit speed
  - External temperature sensor
  - Internal temperature sensor
  - PWM control input
  - Analogue control input
  - Multi-option control input
  - Protection against moisture
  - Protection against salt fog
  - Type of protection: IP 54

1) Fibreglass-reinforced plastic

Nominal data		Air flow	Air flow	Nominal voltage	Voltage range	Sound pressure level	Sound power level	Sintec sleeve bearings Ball bearings	Input power	Nominal speed	Temperature range	Service life L <sub>10</sub> (40 °C) ebm-papst Standard	Service life L <sub>10</sub> (T <sub>max</sub> ) ebm-papst Standard	Life expectancy L <sub>10</sub> IPC (40 °C) see page 17	Curve
Type		m <sup>3</sup> /h	CFM	VDC	VDC	dB(A)	Bel(A)	■ / ■	Watts	rpm	°C	Hours	Hours	Hours	
NEW	DV 6318/2 TDHHP*	630	371	48	36...72	68	7,6	■	75	4000	-20...+65	70 000 / 40 000	117 500	117 500	①
NEW	DV 6318/2 TDH3P*	770	453	48	36...72	73	8,0	■	135	4900	-20...+65	60 000 / 32 500	102 500	102 500	②
NEW	DV 6318/2 TDH4P	1050	617	48	36...72	77	8,7	■	300	6500	-20...+65	50 000 / 27 500	85 000	85 000	③
NEW	DV 6318/2 TDH5P**	1100	647	48	36...72	79	8,9	■	360	6800	-20...+65	40 000 / 22 500	67 500	67 500	④

\* provisional  
\*\* Rotor protrusion a = 3 mm  
Subject to alterations

Speed control range from 1000 rpm up to maximum nominal speed. Stationary at 0 % PWM, maximum speed at sensor break.  
The fans have a speed increase of up to 30%, thus producing a more even characteristic curve.

	n rpm	P <sub>ed</sub> W	L <sub>wA</sub> dB(A)	L <sub>10</sub> (40 °C)	L <sub>10</sub> (65 °C)	L <sub>10</sub> IPC (40 °C)
① ①	4000	65,5	79	70 000	40 000	117 500
① ②	3835	64,5	78	72 500	40 000	122 500
① ③	3815	64,5	76	75 000	42 500	127 500
① ④	3930	65	76	77 500	42 500	130 000
① ⑤	4240	66	79	77 500	42 500	130 000
② ①	4900	120	83	60 000	32 500	102 500
② ②	4690	119	82	67 500	37 500	115 000
② ③	4670	119	80	72 500	40 000	122 500
② ④	4870	120	81	75 000	42 500	127 500
② ⑤	5190	121	85	75 000	42 500	127 500

	n rpm	P <sub>ed</sub> W	L <sub>wA</sub> dB(A)	L <sub>10</sub> (40 °C)	L <sub>10</sub> (65 °C)	L <sub>10</sub> IPC (40 °C)
③ ①	6500	280	90	50 000	27 500	85 000
③ ②	6230	275	89	62 500	35 000	105 000
③ ③	6200	280	88	70 000	40 000	117 500
③ ④	6450	281	88	72 500	40 000	122 500
③ ⑤	6900	283	92,5	72 500	40 000	122 500
④ ①	6950	345	92	40 000	22 500	67 500
④ ②	6720	345	91	57 500	32 500	97 500
④ ③	6630	345	89,5	62 500	35 000	105 000
④ ④	6850	345	89	67 500	37 500	115 000
④ ⑤	7300	345	94	72 500	40 000	122 500

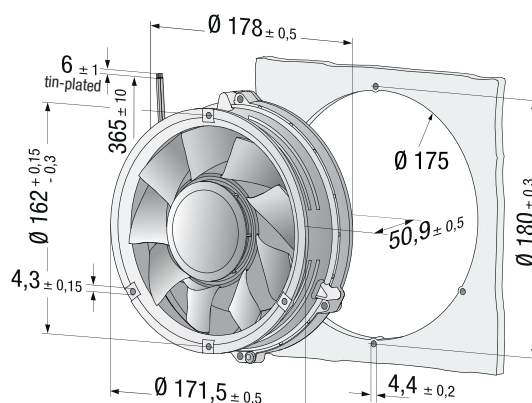
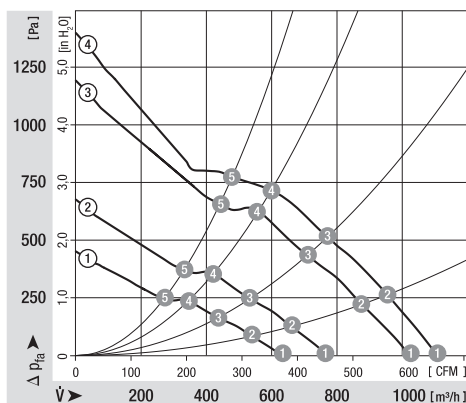



max. 480 m<sup>3</sup>/h

# DC axial fans

Series 6400 172 x 150 x 51 mm



- **Material:** Housing: Die-cast aluminium  
Impeller: GRP<sup>1)</sup> (PA)
  - **Direction of air flow:** Exhaust over struts
  - **Direction of rotation:** Counter-clockwise, seen on rotor
  - **Connection:** On flat plugs 3 x 0.5 mm
  - **Highlights:** Housing with grounding lug for screw M4 x 8 (Torx)
  - **Mass:** 760 g
- **Possible special versions:** (See chapter DC fans - specials)
    - Speed signal
    - Go / No-go alarm
    - Alarm with limit speed
    - External temperature sensor
    - Internal temperature sensor
    - PWM control input
    - Analogue control input
    - Protection against moisture
    - Protection against salt fog
    - Type of protection: IP 54

1) Fibreglass-reinforced plastic

Nominal data	Air flow		Nominal voltage	Voltage range	Sound pressure level	Sound power level	Sintec sleeve bearings Ball bearings	Input power***	Nominal speed	Temperature range	Service life L <sub>10</sub> (40 °C) ebm-papst Standard	Service life L <sub>10</sub> (T <sub>max</sub> ) ebm-papst Standard	Life expectancy L <sub>10</sub> IPC (40 °C) see page 17	Curve
	m <sup>3</sup> /h	CFM												
6412 M	350	206	12	8...15	52	6,0	■	12	2 850	-20...+72	80 000 / 37 500	135 000	①	
6424 M	350	206	24	12...32	52	6,0	■	12	2 850	-20...+72	80 000 / 37 500	135 000	①	
6424	410	241	24	12...28	57	6,4	■	17	3 400	-20...+72	75 000 / 35 000	127 500	②	
6424 H	480	283	24	12...28	63	7,1	■	26	4 000	-20...+55**	70 000 / 50 000	117 500	③	
6448	410	241	48	28...60	57	6,4	■	17	3 400	-20...+72	75 000 / 35 000	127 500	②	
6448 H*	480	283	48	28...60	63	7,1	■	26	4 000	-20...+55**	70 000 / 50 000	117 500	③	

Subject to alternations

\* Strand 310 mm.

\*\* 72 °C versions on request

\*\*\* Input power at free air flow, these values can be significantly higher in the operating point.

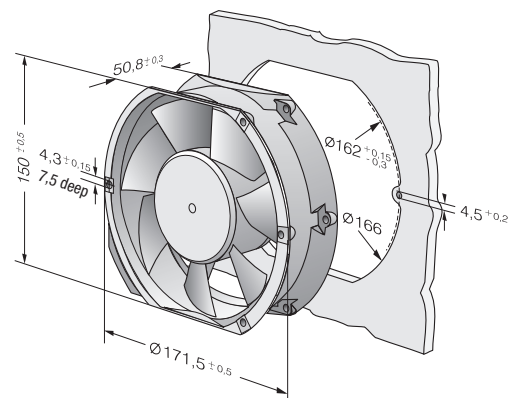
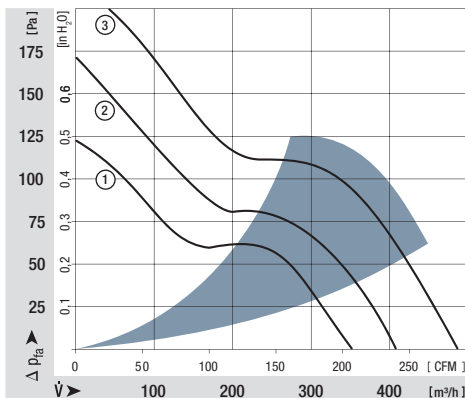



max. 900 m<sup>3</sup>/h

# DC axial fans

Series 6400 TD TURBOFAN 172 x 150 x 51 mm



- **Material:** Housing: Die-cast aluminium  
Impeller: GRP<sup>1)</sup> (PA)
- **Direction of air flow:** Exhaust over struts
- **Direction of rotation:** Counter-clockwise, seen on rotor
- **Connection:** Via single wires AWG 18, 20 or AWG 22, TR 64, speed signal and control input AWG 22
- **Highlights:** 3-phase fan drive with very smooth running and high efficiency. Housing with grounding lug for screw M4 x 8 (Torx) 760 g
- **Mass:** 760 g
- **Possible special versions:** (See chapter DC fans - specials)
  - Speed signal
  - Go / No-go alarm
  - Alarm with limit speed
  - External temperature sensor
  - Internal temperature sensor
  - PWM control input
  - Analogue control input
  - Protection against moisture
  - Protection against salt fog
  - Type of protection: IP 54
  - Reversible direction of rotation

1) Fibreglass-reinforced plastic

Nominal data		Air flow		Nominal voltage	Voltage range	Sound pressure level	Sound power level	Sintec sleeve bearings Ball bearings	Input power**	Nominal speed	Temperature range	Service life L <sub>10</sub> (40 °C) ebm-papst Standard	Service life L <sub>10</sub> (T <sub>max</sub> ) ebm-papst Standard	Life expectancy L <sub>10</sub> (IPC (40 °C) see page 17)	Curve
Type	m <sup>3</sup> /h	CFM	VDC	VDC	dB(A)	Bel(A)	■ / ■	Watts	rpm	°C	Hours	Hours	Hours	Curve	
min max 6424 TD...	90 600	53 353	24	16...28	18 65	— 7,4	■	2 50	800 5 100	-20...+60	70 000 / 45 000	117 500	① ②		
min max 6448 TD...	90 600	53 353	48	40...55*	18 65	— 7,4	■	2 50	800 5 100	-20...+60	70 000 / 45 000	117 500	① ②		
min max 6448 TDHH...	90 900	53 530	48	36...72	18 78	— 8,6	■	2 163	800 7500	-20...+60	70 000 / 45 000	117 500	① ③		

Subject to alternations

\* Variants with an extended voltage range available to deliver on request.

Models 6424 TD..., 6448 TD... and 6448 TDHH... are available in customer-specific, custom-developed variants only. The data specified here is technically feasible benchmark values. The fans can be specially adapted to your application with signal outputs and control inputs. For details of the technical possibilities, refer to the chapters on the sensor signal, alarm signal and control inputs beginning on page 161. \*\* Input power at free air flow, these values can be significantly higher in the operating point.

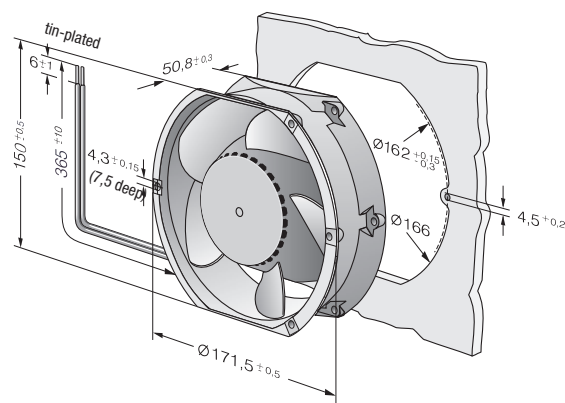
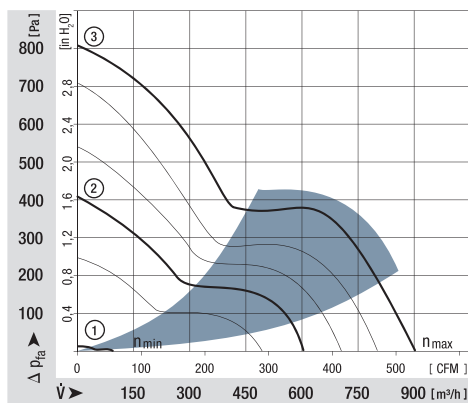

max. 530 m<sup>3</sup>/h

# DC diagonal fans

Series DV 6400 172 x 160 x 51 mm



- **Material:** Housing: Die-cast aluminium  
Impeller: GRP<sup>1)</sup> (PA)
  - **Direction of air flow:** Exhaust over struts
  - **Direction of rotation:** Counter-clockwise, seen on rotor
  - **Connection:** Via single wires AWG 22, TR 64
  - **Highlights:** Housing with grounding lug for screw M4 x 8 (Torx)
  - **Mass:** 820 g
- **Possible special versions:** (See chapter DC fans - specials)
    - Speed signal
    - Go / No-go alarm
    - Alarm with limit speed
    - External temperature sensor
    - Internal temperature sensor
    - PWM control input
    - Analogue control input
    - Protection against moisture
    - Protection against salt fog
    - Type of protection: IP 54

1) Fibreglass-reinforced plastic

Nominal data	Air flow	Air flow	Nominal voltage	Voltage range	Sound pressure level	Sound power level	Sintec sleeve bearings Ball bearings	Input power	Nominal speed	Temperature range	Service life L <sub>10</sub> (40 °C) ebm-papst Standard	Service life L <sub>10</sub> (T <sub>max</sub> ) ebm-papst Standard	Life expectancy L <sub>10</sub> IPC (40 °C) see page 17	Curve
Type	m <sup>3</sup> /h	CFM	VDC	VDC	dB(A)	Bel(A)	□/■	Watts	rpm	°C	Hours	Hours	Hours	①
DV 6424	530	312	24	16...28	65	7,3	■	40	4 300	-20...+75	90 000 / 35 000	152 500	152 500	①
DV 6448	530	312	48	28...60	65	7,3	■	40	4 300	-20...+75	90 000 / 35 000	152 500	152 500	①

Subject to alternations

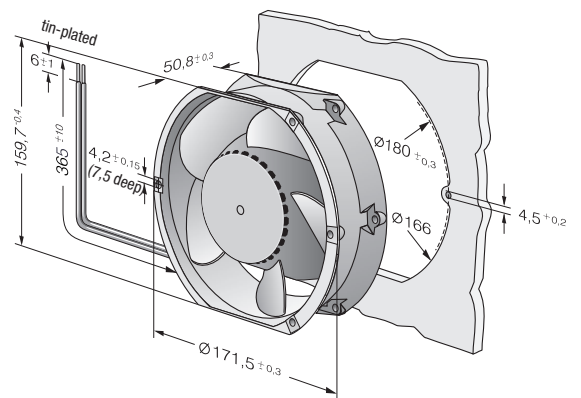
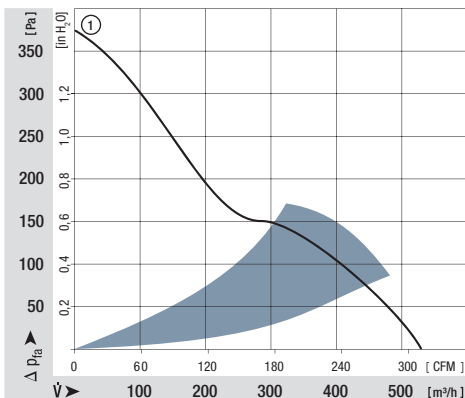

max. 680 m<sup>3</sup>/h

# DC diagonal fans

Series DV 6400 TD TURBOFAN 172 x 160 x 51 mm



- **Material:** Housing: Die-cast aluminium  
Impeller: GRP<sup>1)</sup> (PA)
  - **Direction of air flow:** Exhaust over struts
  - **Direction of rotation:** Counter-clockwise, seen on rotor
  - **Connection:** Via single wires AWG 22, TR 64
  - **Highlights:** 3-phase fan drive with very smooth running and high efficiency. Housing with grounding lug for screw M4 x 8 (Torx)
  - **Mass:** 820 g
- **Possible special versions:** (See chapter DC fans - specials)
    - Speed signal
    - Go / No-go alarm
    - Alarm with limit speed
    - External temperature sensor
    - Internal temperature sensor
    - PWM control input
    - Analogue control input
    - Protection against moisture
    - Protection against salt fog
    - Type of protection: IP 54
    - Reversible direction of rotation

1) Fibreglass-reinforced plastic

Nominal data		Air flow	Air flow	Nominal voltage	Voltage range	Sound pressure level	Sound power level	Sinter sleeve bearings Ball bearings	Input power*	Nominal speed	Temperature range	Service life L <sub>10</sub> (40 °C) ebm-papst Standard	Service life L <sub>10</sub> (T <sub>max</sub> ) ebm-papst Standard	Life expectancy L <sub>10</sub> (IPC (40 °C) see page 17	Curve
Type		m <sup>3</sup> /h	CFM	VDC	VDC	dB(A)	Bel(A)	■/■	Watts	rpm	°C	Hours	Hours	Hours	Curve
DV 6424 TD		680	400	24	16...28	71	7,9	■	91	5 500	-20...+60	65 000 / 40 000	110 000	110 000	②
min max	DV 6424 TD...	100	59	24	16...28	29	—	■	2	800	-20...+60	65 000 / 40 000	110 000	110 000	①
		680	400			71	7,9		91	5 500					②
min max	DV 6448 TD...	100	59	48	40...55	29	—	■	2	800	-20...+60	65 000 / 40 000	110 000	110 000	①
		680	400			71	7,9		86	5 500					②

Subject to alternations

Models DV 6424 TD... and DV 6448 TD... are available in customer-specific, custom-developed variants only.

The data specified here is technically feasible benchmark values. The fans can be specially adapted to your application with signal outputs and control inputs.

For details of the technical possibilities, refer to the chapters on the sensor signal, alarm signal and control inputs beginning on page 161.

\* Input power at free air flow, these values can be significantly higher in the operating point.

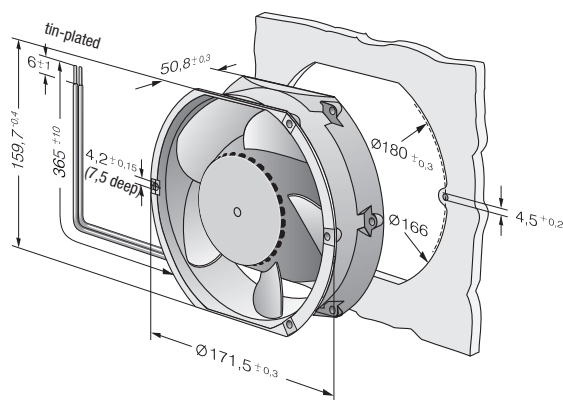
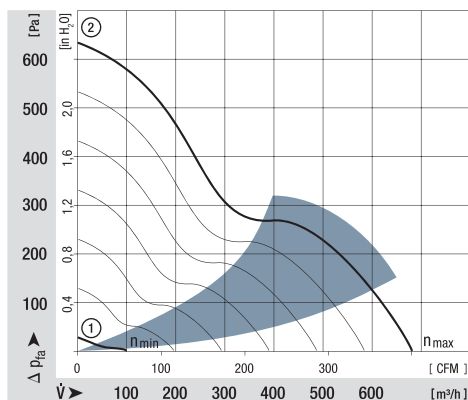

max. 1220 m<sup>3</sup>/h  
**S-Force**

## DC axial fans

Series 2200 FTD 220 x 200 x 51 mm



- **Material:** Housing: Die-cast aluminium  
Impeller: GRP<sup>1)</sup> (PA)
- **Direction of air flow:** Exhaust over struts
- **Direction of rotation:** Counter-clockwise, seen on rotor
- **Connection:** Via single wires AWG 18, 20 or AWG 22, TR 64, speed signal and control input AWG 22
- **Highlights:** 3-phase fan drive with very smooth running and high efficiency. Housing with grounding lug for screw M4 x 8 (Torx)
- **Mass:** 1000 g
- **Possible special versions:** (See chapter DC fans - specials)
  - Speed signal
  - Go / No-go alarm
  - Alarm with limit speed
  - External temperature sensor
  - Internal temperature sensor
  - PWM control input
  - Analogue control input
  - Multi-option control input
  - Protection against moisture
  - Protection against salt fog
  - Type of protection: IP 54

1) Fibreglass-reinforced plastic

Nominal data	Air flow		Nominal voltage	Voltage range	Sound pressure level	Sound power level	Sintec sleeve bearings Ball bearings	Input power*	Nominal speed	Temperature range	Service life L <sub>10</sub> (40 °C) ebm-papst Standard	Service life L <sub>10</sub> (T <sub>max</sub> ) ebm-papst Standard	Life expectancy L <sub>10</sub> IPC (40 °C) see page 17	Curve
	m <sup>3</sup> /h	CFM												
2214 F/2 TDHO	790	465	24	16...30	62	7,1	■	35	4250	-25...+75	90 000 / 42 500	152 500	①	
2214 F/2 TDHHO	940	553	24	16...36	66	7,4	■	48	5000	-25...+70	85 000 / 42 500	142 500	②	
2218 F/2 TDHO	790	465	48	36...57	62	7,1	■	35	4250	-25...+75	90 000 / 42 500	152 500	①	
2218 F/2 TDHHO	940	553	48	36...72	66	7,4	■	48	5000	-25...+70	85 000 / 42 500	142 500	②	
2218 F/2 TDH4P	1220	718	48	36...72	72	8,2	■	103	6500	-20...+65	70 000 / 40 000	117 500	③	

Subject to alternations

Speed control range from 1000 rpm up to maximum nominal speed. Stationary at 0 % PWM / 0 V, Type O: stationary at sensor break; Type P: maximum speed at sensor break.

\* Input power at free air flow, these values can be significantly higher in the operating point.

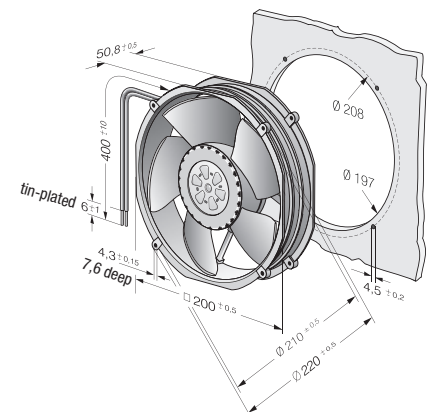
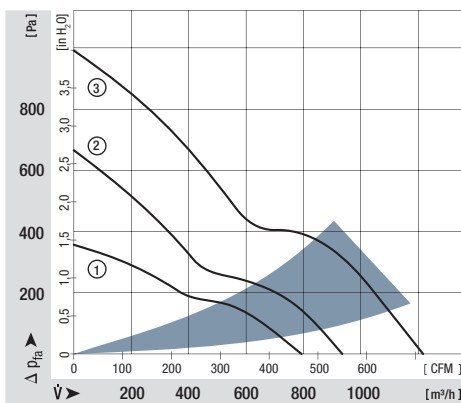

max. 1000 m<sup>3</sup>/h

## DC axial fans

Series 2200 TD 225 x 225 x 80 mm



- **Material:** Wall ring: Die-cast aluminium  
Impeller: GRP<sup>1)</sup> (PA)
  - **Direction of air flow:** Exhaust over struts
  - **Direction of rotation:** Counter-clockwise, seen on rotor
  - **Connection:** With terminal strip
  - **Highlights:** 3-phase fan drive with very smooth running  
Fully integrated electronic commutation
  - **Mass:** 2,1 kg
- **Possible special versions:** (See chapter DC fans - specials)
    - Speed signal
    - Go / No-go alarm
    - Alarm with limit speed
    - External temperature sensor
    - Internal temperature sensor
    - PWM control input
    - Analogue control input
    - Multi-option control input
    - Protection against moisture
    - Type of protection: IP 54

1) Fibreglass-reinforced plastic

Nominal data	Air flow		Nominal voltage	Voltage range	Sound pressure level	Sound power level	Sintec sleeve bearings Ball bearings	Input power*	Nominal speed	Temperature range	Service life L <sub>10</sub> (40 °C) ebm-papst Standard	Service life L <sub>10</sub> (T <sub>max</sub> ) ebm-papst Standard	Life expectancy L <sub>10</sub> (IPC (40 °C) see page 17	Curve
	m <sup>3</sup> /h	CFM												
2214/2 TDO	1000	588	24	16...30	59	6,8	■	50	3 000	-20...+60	80 000 / 50 000	135 000	①	
2218/2 TDO	1000	588	48	36...57	59	6,8	■	50	3 000	-20...+60	80 000 / 50 000	135 000	①	

Subject to alternations

\* Input power at free air flow, these values can be significantly higher in the operating point.

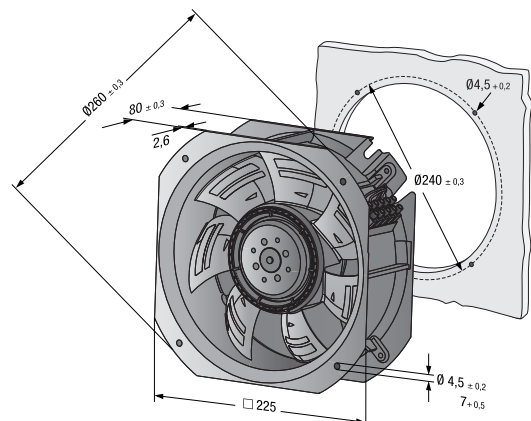
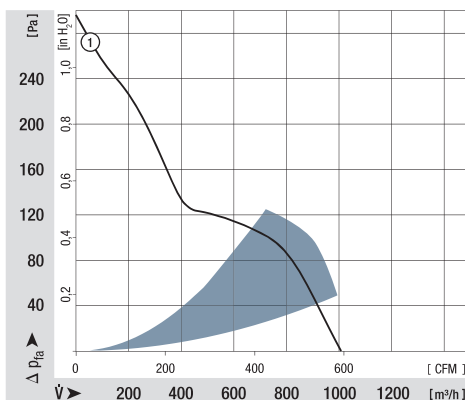

max. 1245 m<sup>3</sup>/h

# DC diagonal module

225 x 225 x 80 mm



- **Material:** Housing: Fibreglass-reinforced plastic (PA6)  
Impeller: Fibreglass-reinforced plastic (PA)
- **Direction of air flow:** Exhaust over struts
- **Direction of rotation:** Clockwise, seen on rotor
- **Connection:** Via connection line AWG 20, 4x brass lead tips crimped
- **Mass:** 1,7 kg
- **Operation mode:** Continuous operation (S1)

Nominal data		Curve	Nominal voltage	Voltage range	Air flow	Speed / rpm	Input power	Current draw	Sound power level	Perm. amb. temp.	Technical features and electrical connections
Type	Motor		VDC	VDC	m <sup>3</sup> /h	rpm	W	A	dB(A)	°C	
K1G 200-AD65-04	M1G 074-BF	①	24	16...28	1020	3 400	95	4,7	76	-25...+60	p. 258 / J5)
K1G 200-AD31-02	M1G 074-BF	②	24	16...28	1045	3 520	107	5,4	77	-25...+70	p. 258 / J5)
K1G 200-AD49-04	M1G 074-BF	③	48	36...57	1095	3 650	120	3,4	77	-25...+60	p. 258 / J5)
K1G 200-AD37-02	M1G 074-BF	④	48	36...57	1245	4 140	183	5,6	81	-25...+70	p. 258 / J5)

Subject to alternations

	n rpm	P <sub>ed</sub> W	I A	Lw <sub>A</sub> dB(A)
① ①	3400	95	4,70	76
① ②	3410	116	5,61	74
① ③	3410	119	5,75	74
① ④	3410	117	5,62	76
② ①	3520	107	5,30	77
② ②	3520	127	6,24	75
② ③	3520	129	6,31	76
② ④	3520	126	6,18	76
③ ①	3650	120	3,40	77
③ ②	3650	141	3,90	75
③ ③	3650	145	3,99	76
③ ④	3650	141	3,88	78
④ ①	4140	183	5,60	81
④ ②	4090	212	6,46	79
④ ③	4060	213	6,52	79
④ ④	4110	211	6,43	80

Air performance measured as per: ISO 5801, Installation category A, without protection against accidental contact.

Suction-side noise levels: LwA as per ISO 13347, LpA measured at 1 m distance to fan axis.

The acoustic values given are only valid under the measurement conditions listed and may vary depending on the installation situation.

With any deviation to the standard setup, the specific values have to be checked and reviewed once installed or fitted! For detailed information see <http://www.ebmpapst.com/general-conditions>

**Cable assignment:**

- Red = UN
- Yellow = 0-10 VDC
- White = Speed monitoring output
- Blue = GND

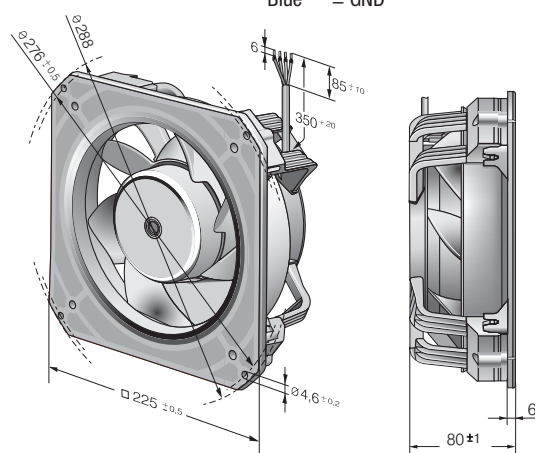
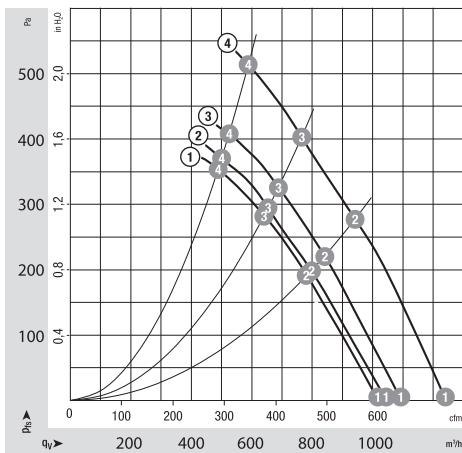



max. 905 m<sup>3</sup>/h

# DC diagonal module

225 x 225 x 89 mm



- **Material:** Housing: Fibreglass-reinforced plastic (PA6)  
Impeller: Fibreglass-reinforced plastic (PA)
- **Direction of air flow:** Exhaust over struts
- **Direction of rotation:** Clockwise, seen on rotor
- **Connection:** Via connection line AWG 16, 4x brass lead tips crimped
- **Mass:** 2,2 kg
- **Operation mode:** Continuous operation (S1)

Nominal data		Curve	Nominal voltage	Voltage range	Air flow	Speed / rpm	Input power	Current draw	Sound power level	Perm. amb. temp.	Technical features and electrical connections
Type	Motor		VDC	VDC	m <sup>3</sup> /h	rpm	W	A	dB(A)	°C	
K3G 200-BD46-04	M3G 074-CF	①	24	16...28	725	4120	170	7,0	80	-25...+60	p. 258 / J5)
K3G 200-BD44-02	M3G 074-CF	②	24	16...28	805	4830	275	11,5	84	-25...+60	p. 258 / J5)
K3G 200-BD64-04	M3G 074-CF	③	48	36...57	900	4890	280	5,9	85	-25...+60	p. 258 / J5)
K3G 200-BDA8-02	M3G 074-CF	④	48	36...57	905	5470	400	8,4	88	-25...+60	p. 258 / J5)

Subject to alternations

	n rpm	P <sub>ed</sub> W	I A	L <sub>WA</sub> dB(A)
① ①	4120	170	7,0*	80
① ②	4025	180	7,52*	77
① ③	4005	187	7,80*	76
① ④	4045	187	7,78*	78
② ①	4830	275	11,5*	84
② ②	4720	294	12,24*	81
② ③	4685	299	12,48*	80
② ④	4715	295	12,30*	83
③ ①	4890	280	5,9*	85
③ ②	4795	300	6,27*	81
③ ③	4755	307	6,41*	80
③ ④	4780	304	6,35*	82
④ ①	5470	400	8,4*	88
④ ②	5365	426	8,89*	85
④ ③	5310	438	9,17*	83
④ ④	5355	431	9,01*	87

Air performance measured as per: ISO 5801, Installation category A, without protection against accidental contact.

Suction-side noise levels: L<sub>WA</sub> as per ISO 13347, L<sub>pA</sub> measured at 1 m distance to fan axis.

The acoustic values given are only valid under the measurement conditions listed and may vary depending on the installation situation.

With any deviation to the standard setup, the specific values have to be checked and reviewed once installed or fitted! For detailed information see <http://www.ebmpapst.com/general-conditions>

\* current measured at nominal voltage

**Cable assignment:**

- Red = UN
- Yellow = 0-10 VDC
- White = Speed monitoring output
- Blue = GND

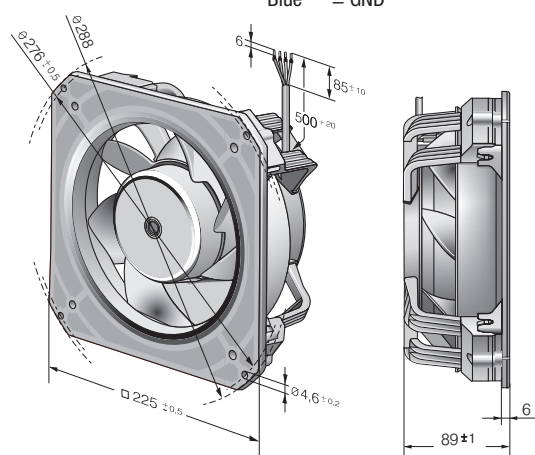
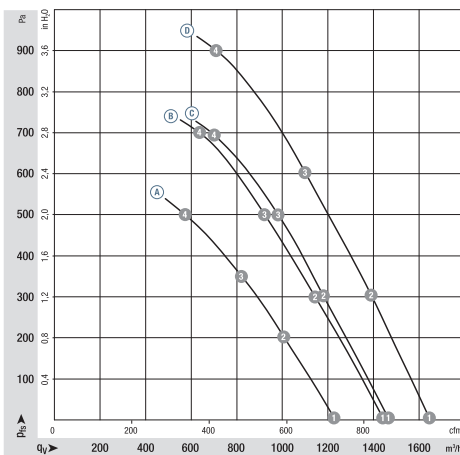

max. 2070 m<sup>3</sup>/h

# DC axial fans

Ø 250 mm



- **Material:** Wall ring: Die-cast aluminium  
Blades: Plastic (PP)  
Rotor: Thick layer passivated
- **Number of blades:** 7
- **Direction of air flow:** "V"
- **Direction of rotation:** Counter-clockwise, seen on rotor
- **Insulation class:** "B"
- **Mounting position:** Any
- **Condensate discharges:** On rotor side
- **Operation mode:** Continuous operation (S1)
- **Bearings:** Maintenance-free ball bearings

Nominal data		Curve	Nominal voltage	Voltage range	Air flow	Speed / rpm	Input power	Current draw	Max. back-pressure	Perm. amb. temp.	Technical features and electrical connections
Type	Motor	VDC	VDC	m <sup>3</sup> /h	rpm	W	A	Pa	°C		
<b>W1G250-HJ87 -02</b>	M1G074-BF	Ⓐ	24	16-28	2070	3090	120	6,80	150	-25...+60	p. 254 / E)
<b>W1G250-HJ63 -02</b>	M1G074-BF	Ⓑ	48	36-57	2070	3090	120	3,40	150	-25...+60	p. 254 / E)

Subject to alternations

Curve:

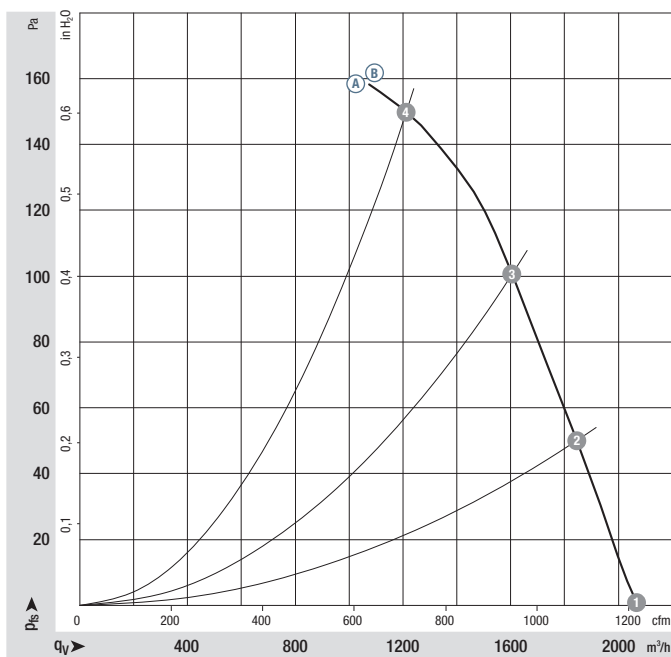

	n rpm	P <sub>ed</sub> W	I A	L <sub>WA</sub> dB(A)
Ⓐ ①	3090	120	6,80	74
Ⓐ ②	2950	124	7,10	73
Ⓐ ③	2820	127	7,43	73
Ⓐ ④	2730	130	7,80	78
Ⓑ ①	3090	120	3,40	74
Ⓑ ②	2950	124	3,55	73
Ⓑ ③	2820	127	3,74	73
Ⓑ ④	2730	130	3,90	78

Air performance measured as per: ISO 5801, Installation category A, without protection against accidental contact. Suction-side noise levels: LWA as per ISO 13347, LpA measured at 1 m distance to fan axis. The acoustic values given are only valid under the measurement conditions listed and may vary depending on the installation situation. With any deviation to the standard setup, the specific values have to be checked and reviewed once installed or fitted!  
For detailed information see <http://www.ebmpapst.com/general-conditions>

- **Technical features:** See electrical connections p. 254
- **EMC:** Interference emission acc. to EN 55022 (Class B)  
Interference immunity acc. to EN 61000-6-2 (industrial environment)
- **Electrical connection:** Via terminal strip
- **Protection class:** I
- **Product conforming to standards:** EN 60950-1

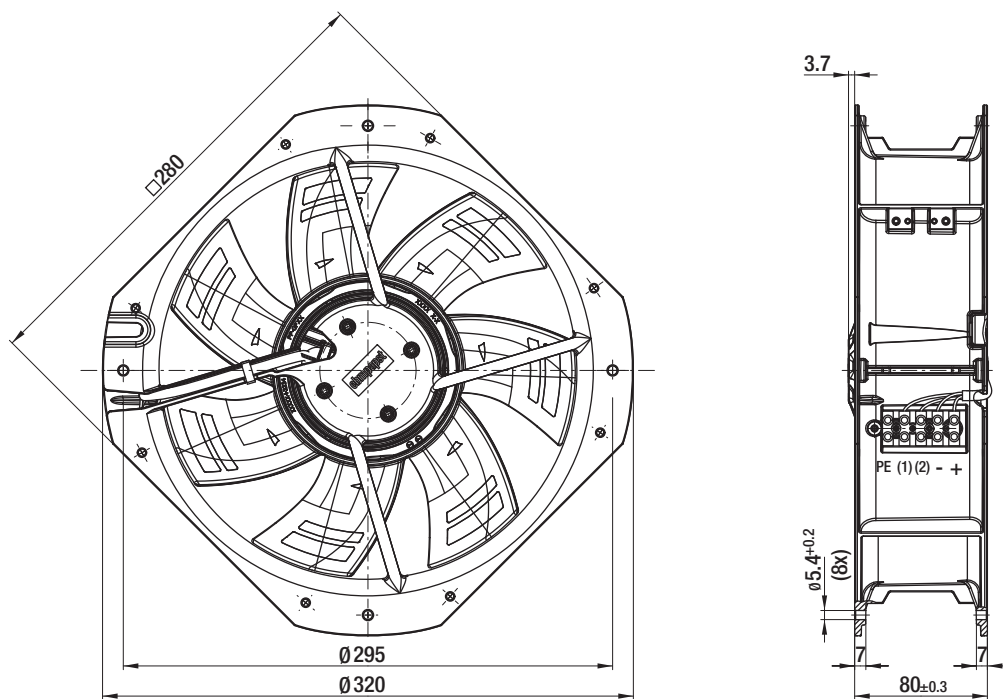

(1) Control input  
(2) Speed output

"V"

max. 2345 m<sup>3</sup>/h

# DC axial fans – HyBlade®

Ø 300 mm



- **Material:** Guard grille: Steel, phosphated and coated in black plastic  
Wall ring: Sheet steel, pre-galvanised and coated in black plastic  
Blades: Plastic (PP)  
Rotor: Coated in black
- **Number of blades:** 5
- **Direction of air flow:** "V"
- **Direction of rotation:** Counter-clockwise, seen on rotor
- **Type of protection:** IP 42
- **Insulation class:** "B"
- **Mounting position:** Any
- **Condensate discharges:** None
- **Operation mode:** Continuous operation (S1)
- **Bearings:** Maintenance-free ball bearings

Nominal data		Curve	Nominal voltage		Voltage range	Air flow	Speed / rpm	Input power	Current draw	Max. back-pressure	Perm. amb. temp.	Technical features and electrical connections
Type	Motor	VDC	VDC	m <sup>3</sup> /h	rpm	W	A	Pa	°C			
*1G 300	M1G 074-CF	Ⓐ	24	16-28	2320	1830	80	3,80	100	-25..+60	p. 258 / J5)	
*1G 300	M1G 074-CF	Ⓑ	48	36-57	2345	1830	80	1,90	100	-25..+60	p. 258 / J5)	

Subject to alternations

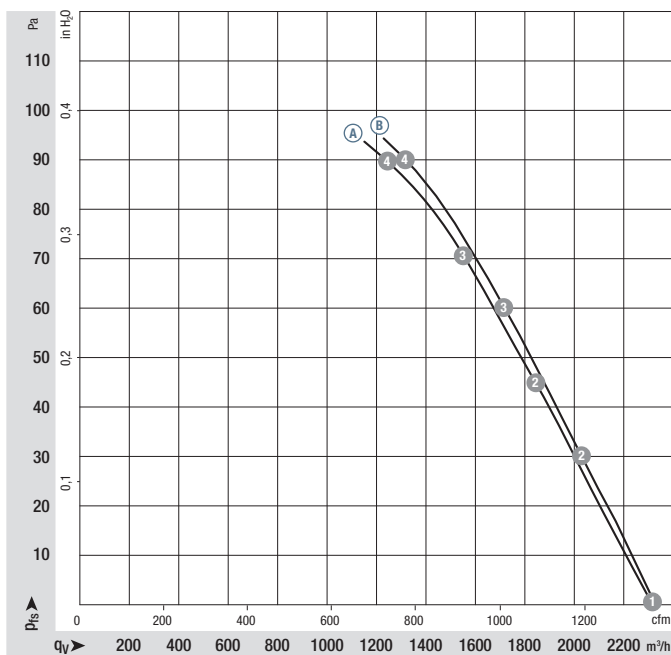

Curve:



	n rpm	P <sub>ed</sub> W	I A	L <sub>WA</sub> dB(A)
Ⓐ ①	1810	80	3,80	67
Ⓐ ②	1730	86	4,03	67
Ⓐ ③	1690	87	4,10	66
Ⓐ ④	1635	89	4,21	70
Ⓑ ①	1870	87	2,00	68
Ⓑ ②	1805	90	2,10	67
Ⓑ ③	1765	91	2,13	67
Ⓑ ④	1695	92	2,19	69

Air performance measured as per: ISO 5801, Installation category A, with ebm-papst inlet nozzle without protection against accidental contact. Suction-side noise levels: LWA as per ISO 13347, LpA measured at 1 m distance to fan axis. The acoustic values given are only valid under the measurement conditions listed and may vary depending on the installation situation. With any deviation to the standard setup, the specific values have to be checked and reviewed once installed or fitted! For detailed information see <http://www.ebmpapst.com/general-conditions>

- **Technical features:** See electrical connections p. 258
- **EMC:** Interference emission acc. to EN 55022 (Class B)  
Interference immunity acc. to EN 61000-6-2 (industrial environment)
- **Cable exit:** lateral
- **Product conforming to standards:** EN 60950-1
- **Approvals:** GOST, CSA C22.2 Nr. 77, UL 1004-1

Direction of air flow		Mass without attachments		Mass with full round nozzle		Mass with guard grille for short nozzle
	Without attachments	kg	With full round nozzle	kg	With guard grille for short nozzle	kg
"V"	A1G 300-AC19 -54	1,8	W1G300-DC19 -54	3,8	S1G 300-AC19 -54	2,8
"V"	A1G 300-AC33 -54	1,8	W1G300-DC33 -54	3,8	S1G 300-AC33 -54	3,1

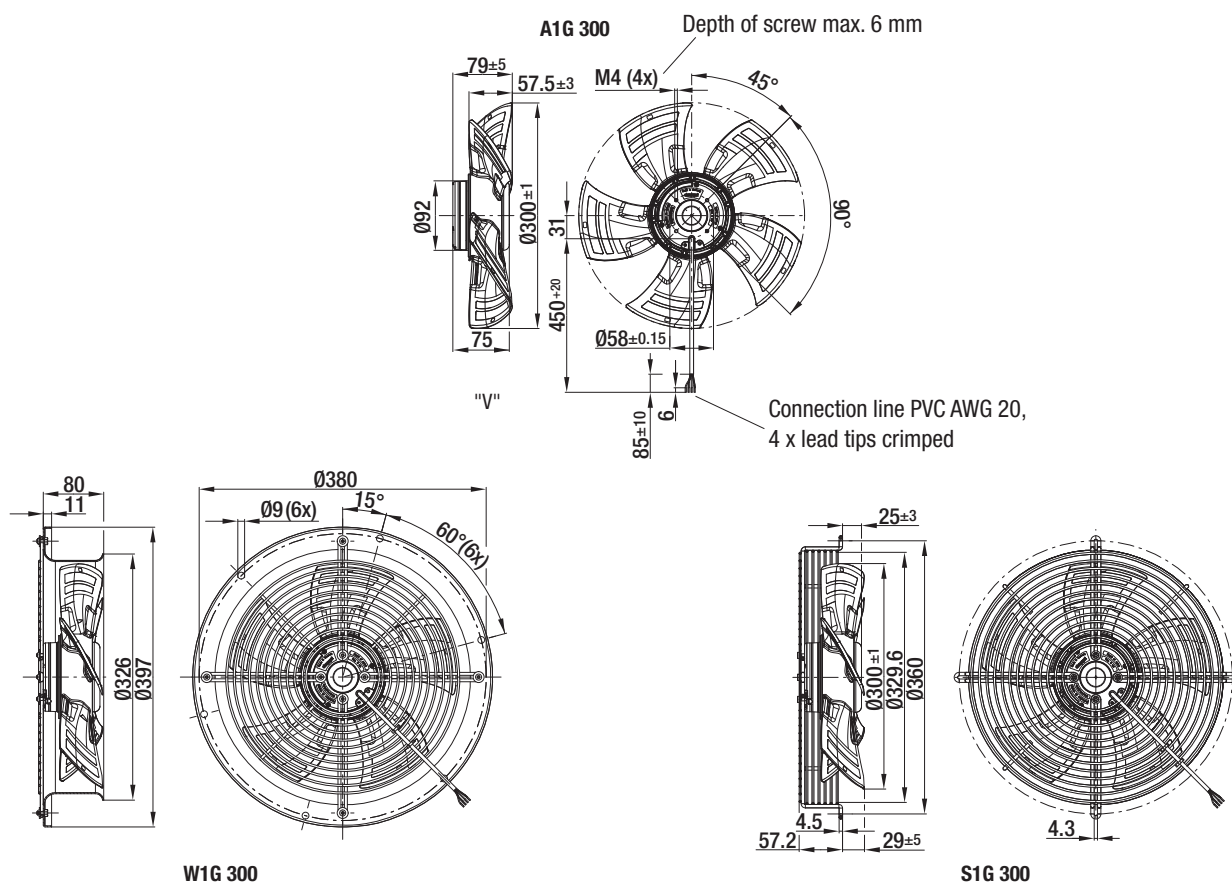





# DC centrifugal fans



DC centrifugal fan overview	91
DC centrifugal fans	93
DC tangential fans	134
DC centrifugal fans and blowers	136

# DC centrifugal fans

## Technical information



### Product line

Our centrifugal product line includes fans for every application. Whether as free-running impellers with a diameter between 97 mm and 225 mm or as assemblies in a ready-to-install, compact housing with inlet nozzle with an edge length between 51 mm and 270 mm. Of course, all models feature high-efficiency, brushless motor technology.

### Electronic protection against reverse polarity

ebm-papst DC fans have electronically commutated drives with electronic protection against reverse polarity. The electronics are conveniently located in the fan hub.

### Product life expectancy

A distinctive feature of DC fan technology is the convincingly high product life expectancy. Thanks to the excellent efficiency of the brushless drives, the thermal load of the bearings is reduced, thus considerably increasing the life expectancy of the fans.

### Type of protection

DC fans with sleeve and ball bearings are powered by class E insulated motors. All ebm-papst fans conform to the requirements of type of protection IP 20. Fans conforming to IP 54 / IP 68 and special types of protection are also available.

### Voltage range

Many of our DC fans can be operated on voltages that are up to 50% lower and 25% higher than their nominal voltage (see Voltage range in the technical tables). This enables the air performance to be adapted to the cooling requirements and allows the noise to be reduced, even if the fan does not have a control input.

### Closed-loop speed control and monitoring

Closed-loop speed control and function monitoring are becoming increasingly important in many applications. ebm-papst offers many fans in the standard design with a control input and open collector speed signal.

### S-Force centrifugal – RadiCal

The new S-Force centrifugal fans provide peak performance among fans of this type. With air flow capacity of over 1500 m<sup>3</sup>/h and a pressure build-up of up to 1000 pascals, the highest heat flows are manageable. In addition, the models are extremely efficient due to the multi-pole, electronically commutated drive motors and can be adapted individually to every application thanks to intelligent motor features. Some models use our new, highly efficient RadiCal impellers.



# Centrifugal fans for DC operation

## Overview of technically feasible designs

Dimensions	Centrifugal fans		VDE, UL, CSA	Sinter sleeve bearings/ball bearings	Speed signal	Go / No-go alarm	Alarm with limit speed	External temperature sensor	Internal temperature sensor	PWM control input	Analogue control input	Multi-option control input	Humidity protection	IP >= IP 54	IP >= IP 68	Salt fog protection	Page
	Series	mm															
	RV 40	105 x 59 x 79	• ■	•	-	-	-	-	-	-	-	-	•	-	-	-	93
	RLF 35	51 x 51 x 15	ja ■	•	-	-	-	•	-	-	-	-	•	-	-	-	94
	RL 48	76 x 76 x 27	ja ■	•	•	•	•	•	•	•	-	-	•	-	-	-	95
	RL 65	97 x 93,5 x 33	ja ■	•	•	•	•	•	•	•	-	-	•	-	-	-	96
	RL 90 N	121 x 121 x 37	ja □/■	•	•	•	•	•	•	•	-	-	•	•	•	•	97
	RLF 100	127 x 127 x 25	ja ■	•	•	•	•	•	•	•	-	-	•	•	-	-	98
	RG 90 N	135 x 135 x 38	ja □/■	•	•	•	•	•	•	•	-	-	•	•	•	•	99
	RG 125 N	180 x 180 x 40	ja ■	•	•	•	•	•	•	•	-	-	•	•	•	•	100
	RG 160 N	220 x 220 x 56	ja ■	•	•	•	•	•	•	•	-	-	•	•	-	•	101
	RG 160 NTD	220 x 220 x 56	ja ■	•	•	•	•	•	•	•	-	-	•	•	-	•	102
<i>S-Force</i>	RG 190 TD	225 x 225 x 85	ja ■	•	•	•	•	•	•	•	-	-	•	•	-	•	103
<i>S-Force</i>	RG 220 TD	270 x 270 x 99	ja ■	•	•	•	•	•	•	•	-	-	•	•	-	•	104
<i>S-Force</i>	RG 225 TD	270 x 270 x 132	ja ■	•	•	•	•	•	•	•	-	-	•	•	-	•	105
<i>S-Force</i>	RET 97 TD	∅ 97 x 41	ja ■	•	•	•	•	•	•	•	-	-	•	-	-	-	106
	REF 100	∅ 100 x 25	ja ■	•	•	•	•	•	•	•	-	-	•	•	-	-	107
	RER 101	∅ 101 x 52	ja ■	•	•	•	•	•	•	•	-	-	•	-	-	-	108
<i>S-Force</i>	RER 120 TD	∅ 120 x 54	ja ■	•	•	•	•	•	•	•	-	-	•	-	-	-	109
	RER 125 N	∅ 138 x 35	ja ■	•	•	•	•	•	•	•	-	-	•	•	•	•	112
<i>S-Force</i>	RER 133 TD	∅ 133 x 91	ja ■	•	•	•	•	•	•	•	-	-	•	•	-	•	113
	RER 160 N	∅ 165 x 51	ja ■	•	•	•	•	•	•	•	-	-	•	•	-	•	114
<i>S-Force</i>	RER 160 NTD	∅ 165 x 51	ja ■	•	•	•	•	•	•	•	-	-	•	•	-	-	115
<i>S-Force</i>	REF 175 TD	∅ 175 x 55	ja ■	•	•	•	•	•	•	•	-	-	•	•	-	-	116
<i>S-Force</i>	RER 175 TD	∅ 175 x 69	ja ■	•	•	•	•	•	•	•	-	-	•	•	-	•	117
<i>S-Force</i>	RER 190 TD	∅ 190 x 69	ja ■	•	•	•	•	•	•	•	-	-	•	•	-	•	118
<i>S-Force</i>	RER 220 TD	∅ 220 x 71	ja ■	•	•	•	•	•	•	•	-	-	•	•	-	•	124
<i>S-Force</i>	RER 225 TD	∅ 225 x 99	ja ■	•	•	•	•	•	•	•	-	-	•	•	-	•	125
	QG 030	201...413 x 50 x 48	ja □/■	•	-	-	-	-	-	-	-	-	•	-	-	-	134

\* approvals-applied for    - not yet available    □ Sleeve bearings  
 • available    ■ Ball bearings

Please note that these special versions are not possible for all voltages and speeds, and not in all combinations. The special versions are designed for specific customers and projects. As a rule they are not available off the shelf and are tied to minimum volumes.

Please consult your customer support representative about the feasibility of your special variant.

### Optional special versions (see page 12)

On the catalogue pages and in the overview on page 12, we provide information about the special designs that are technically feasible in the fan series. Please note that these special versions are not possible for all voltages and speeds, and not in all combinations. The special

versions are designed for specific customers and projects and are not available off the shelf usually.

max. 24 m<sup>3</sup>/h

# DC centrifugal fans

Series RV 40 105 x 59 x 79 mm



- **Material:** Scroll housing: GRP<sup>1)</sup>  
Impeller: GRP<sup>1)</sup>
  - **Direction of air flow:** Axial: Intake  
Centrifugal: Exhaust
  - **Connection:** Via single wires AWG 26,  
TR 64
  - **Highlights:** Forwards-curved impeller
  - **Mass:** 100 g
- **Possible special versions:**  
(See chapter DC fans - specials)
    - Speed signal
    - Protection against moisture

1) Fibreglass-reinforced plastic

Nominal data	Air flow		Nominal voltage	Voltage range	Sound power level	Sintec sleeve bearings Ball bearings	Input power	Nominal speed	Temperature range	Service life L <sub>10</sub> (40 °C) ebm-papst Standard	Service life L <sub>10</sub> (T <sub>max</sub> ) ebm-papst Standard	Life expectancy L <sub>10</sub> IPC (40 °C) see page 17	Curve
	m <sup>3</sup> /h	CFM											
RV 40-18/12 L	18	10,6	12	9...16	4,0	■	2,0	3 900	-20...+70	70 000 / 35 000	117 500	①	
RV 40-18/12 H	24	14,1	12	9...16	5,0	■	4,5	4 800	-20...+70	50 000 / 25 000	85 000	②	

Subject to alternations

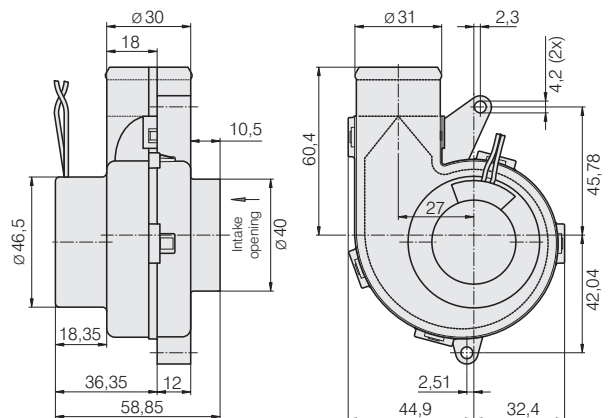
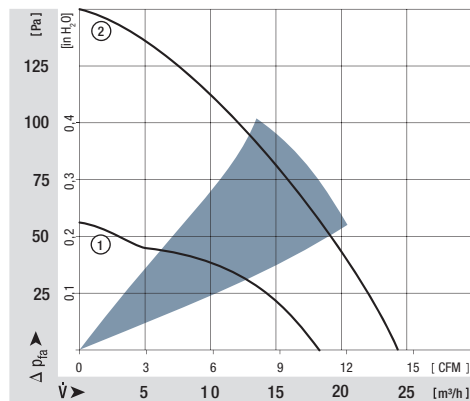

max. 9,6 m<sup>3</sup>/h

## DC centrifugal fans

Series RLF 35 51 x 51 x 15 mm



- **Material:** Scroll housing: GRP<sup>1)</sup>  
Impeller: GRP<sup>1)</sup>
- **Direction of air flow:** Axial: Intake  
Centrifugal: Exhaust
- **Connection:** Via single wires AWG 26,  
TR 64
- **Highlights:** Forwards-curved impeller
- **Mass:** 40 g

- **Possible special versions:**  
(See chapter DC fans - specials)
  - Speed signal
  - PWM control input
  - Protection against moisture

1) Fibreglass-reinforced plastic

Nominal data	Air flow		Nominal voltage	Voltage range	Sound power level	Sintec sleeve bearings Ball bearings	Input power	Nominal speed	Temperature range	Service life L <sub>10</sub> (40 °C) ebm-papst Standard	Service life L <sub>10</sub> (T max) ebm-papst Standard	Life expectancy L <sub>10</sub> (IPC (40 °C) see page 17	Curve
	m <sup>3</sup> /h	CFM											
RLF 35-8/12 N	9,6	5,7	12	8...13,2	5,5	■	3,5	6 700	-20...+70	60 000 / 30 000	102 500	①	
RLF 35-8/14 N	9,6	5,7	24	14...28	5,5	■	4,3	6 700	-20...+70	60 000 / 30 000	102 500	①	

Subject to alternations

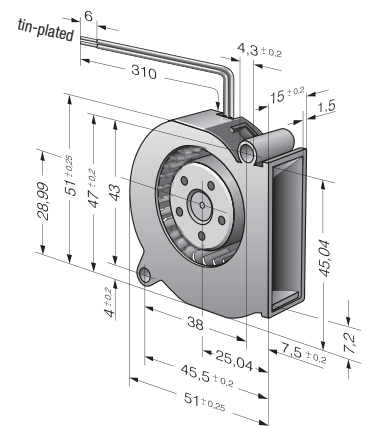
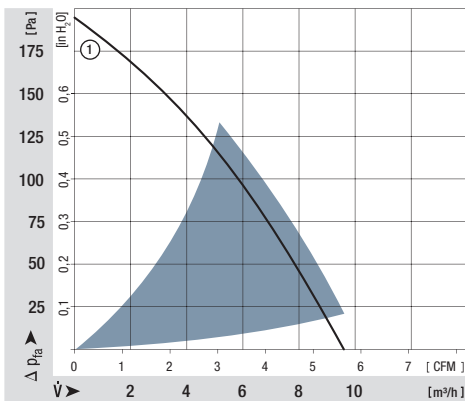



max. 28 m<sup>3</sup>/h

# DC centrifugal fans

Series RL 48 76 x 76 x 27 mm



- **Material:** Scroll housing: GRP<sup>1)</sup>  
Impeller: GRP<sup>1)</sup>
  - **Direction of air flow:** Axial: Intake  
Centrifugal: Exhaust
  - **Connection:** Via single wires AWG 26,  
TR 64
  - **Highlights:** Forwards-curved impeller
  - **Mass:** 75 g
- **Possible special versions:**  
(See chapter DC fans - specials)
    - Speed signal
    - Go / No-go alarm
    - Alarm with limit speed
    - External temperature sensor
    - Internal temperature sensor
    - PWM control input
    - Analogue control input
    - Protection against moisture

1) Fibreglass-reinforced plastic

Nominal data	Air flow		Nominal voltage	Voltage range		Sound power level	Sintec sleeve bearings Ball bearings	Input power	Nominal speed	Temperature range	Service life L <sub>10</sub> (40 °C) ebm-papst Standard	Service life L <sub>10</sub> (T <sub>max</sub> ) ebm-papst Standard	Life expectancy L <sub>10</sub> IPC (40 °C) see page 17	Curve
	m <sup>3</sup> /h	CFM		VDC	VDC									
RL 48-19/12 ML	22	12,9	12	8...15	5,3	■	5,0	3 500	-20...+70	70 000 / 35 000	117 500	①		
RL 48-19/12	28	16,5	12	8...13,5	5,7	■	4,6	4 400	-20...+70	60 000 / 30 000	102 500	②		
RL 48-19/14 ML	22	12,9	24	18...28	5,3	■	5,0	3 500	-20...+70	70 000 / 35 000	117 500	①		
RL 48-19/14	28	16,5	24	18...26,4	5,7	■	4,4	4 400	-20...+70	60 000 / 30 000	102 500	②		

Subject to alternations

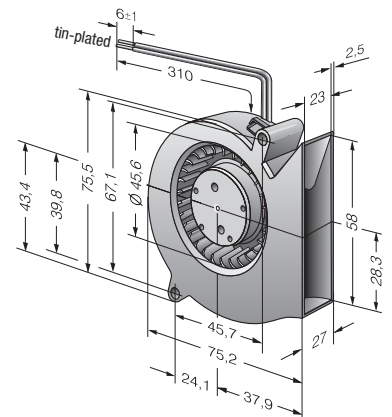
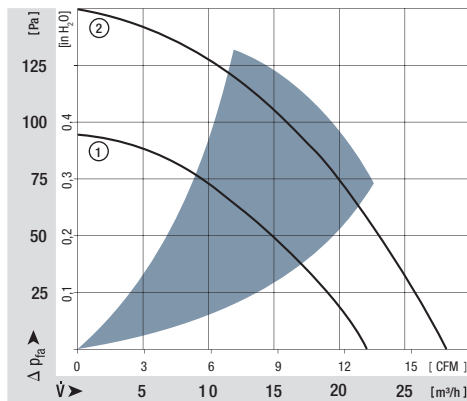

max. 61 m<sup>3</sup>/h

# DC centrifugal fans

Series RL 65 97 x 93,5 x 33 mm



- **Material:** Scroll housing: GRP<sup>1)</sup>  
Impeller: GRP<sup>1)</sup>
  - **Direction of air flow:** Axial: Intake  
Centrifugal: Exhaust
  - **Connection:** Via single wires AWG 26,  
TR 64
  - **Highlights:** Forwards-curved impeller
  - **Mass:** 170 g
- **Possible special versions:**  
(See chapter DC fans - specials)
    - Speed signal
    - Go / No-go alarm
    - Alarm with limit speed
    - External temperature sensor
    - Internal temperature sensor
    - PWM control input
    - Analogue control input
    - Protection against moisture

1) Fibreglass-reinforced plastic

Nominal data	Air flow		Nominal voltage	Voltage range	Sound power level	Sinter sleeve bearings Ball bearings	Input power	Nominal speed	Temperature range	Service life L <sub>10</sub> (40 °C) ebm-papst Standard	Service life L <sub>10</sub> (T max) ebm-papst Standard	Life expectancy L <sub>10</sub> IPC (40 °C) see page 17	Curve
	m <sup>3</sup> /h	CFM											
RL 65-21/12	56	33	12	6,8...13,8	6,6	■	15,0	4 500	-20...+70	60 000 / 30 000	102 500	102 500	①
RL 65-21/12 H	61	36	12	6,8...13,2	6,8	■	19,2	4 900	-20...+55	55 000 / 40 000	92 500	92 500	②
RL 65-21/14	56	33	24	12...26,4	6,6	■	14,0	4 500	-20...+70	60 000 / 30 000	102 500	102 500	①
RL 65-21/14 H	61	36	24	12...26,4	6,8	■	18,0	4 900	-20...+60	55 000 / 35 000	92 500	92 500	②

Subject to alternations

Snap-in fins for easy latch

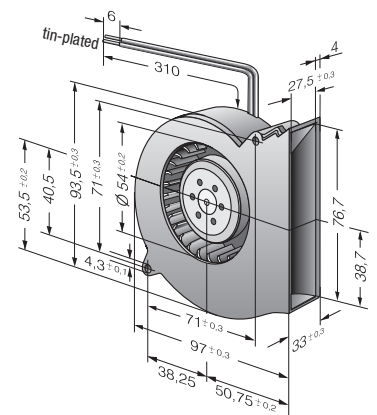
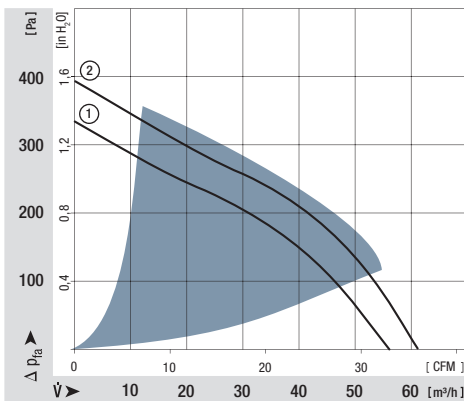
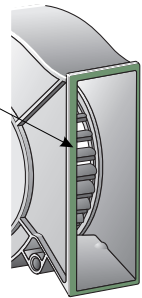

max. 55 m<sup>3</sup>/h

# DC centrifugal fans

Series RL 90 N 121 x 121 x 37 mm



- **Material:** Scroll housing: GRP<sup>1)</sup>  
Impeller: GRP<sup>1)</sup>  
Housing base: Sheet steel
  - **Direction of air flow:** Axial: Intake  
Centrifugal: Exhaust
  - **Connection:** Via single wires AWG 22, TR 64
  - **Highlights:** Forwards-curved impeller
  - **Mass:** 420 g
- **Possible special versions:** (See chapter DC fans - specials)
    - Speed signal
    - Go / No-go alarm
    - Alarm with limit speed
    - External temperature sensor
    - Internal temperature sensor
    - PWM control input
    - Analogue control input
    - Protection against moisture
    - Protection against salt fog
    - Type of protection: IP 54 / IP 68

1) Fibreglass-reinforced plastic

Nominal data	Air flow		Nominal voltage	Voltage range		Sound power level	Sintec sleeve bearings Ball bearings	Input power	Nominal speed	Temperature range	Service life L <sub>10</sub> (40 °C) ebm-papst Standard	Service life L <sub>10</sub> (T <sub>max</sub> ) ebm-papst Standard	Life expectancy L <sub>10</sub> IPC (40 °C) see page 17	Curve
	m <sup>3</sup> /h	CFM		VDC	VDC									
RL 90-18/12 N	40	23,5	12	7...15	5,8	■	6,3	2 500	-30...+75	62 500 / 27 500	105 000	①		
RL 90-18/14 NG	40	23,5	24	12...28	5,8	□	5,6	2 500	-20...+75	62 500 / 27 500	105 000	①		
RL 90-18/14 N	40	23,5	24	12...28	5,8	■	5,6	2 500	-30...+75	62 500 / 27 500	105 000	①		
RL 90-18/18 NH	55	32,4	48	36...53	6,9	■	14,7	3 500	-30...+65	32 500 / 17 500	55 000	②		

Subject to alternations

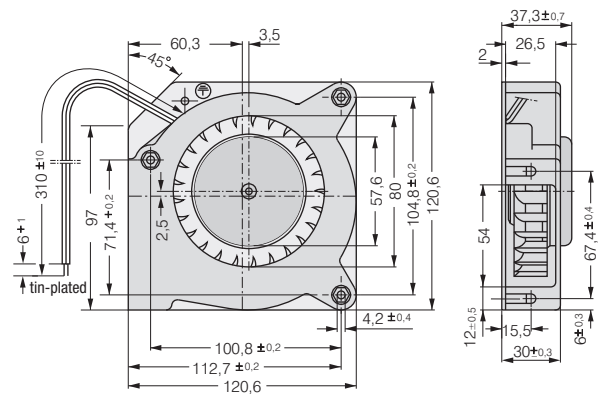
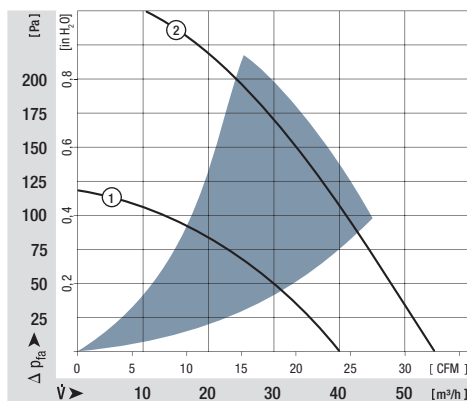

Screw clip M4 or 8-32UNC. Screw-in depth max. 12.5 min. 9.0

max. 80 m<sup>3</sup>/h

# DC centrifugal fans

Series RLF 100 127 x 127 x 25 mm

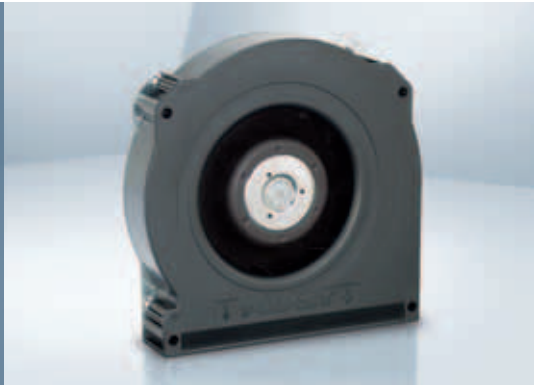

- **Material:** Scroll housing: GRP<sup>1)</sup>  
Impeller: GRP<sup>1)</sup>  
Housing base: Sheet steel
  - **Direction of air flow:** Axial: Intake  
Centrifugal: Exhaust
  - **Connection:** Via single wires AWG 22, TR 64
  - **Highlights:** Optional protective cap for outlet opening  
Backwards-curved impeller
  - **Mass:** 320 g
- **Possible special versions:** (See chapter DC fans - specials)
    - Speed signal
    - Go / No-go alarm
    - Alarm with limit speed
    - External temperature sensor
    - Internal temperature sensor
    - PWM control input
    - Analogue control input
    - Protection against moisture
    - Type of protection: IP 54

<sup>1)</sup> Fibreglass-reinforced plastic

Nominal data	Air flow	Air flow	Nominal voltage	Voltage range	Sound power level	Sinter sleeve bearings Ball bearings	Input power	Nominal speed	Temperature range	Service life L <sub>10</sub> (40 °C) ebm-papst Standard	Service life L <sub>10</sub> (T max) ebm-papst Standard	Life expectancy L <sub>10</sub> (IPC (40 °C) see page 17	Curve
Type	m <sup>3</sup> /h	CFM	VDC	VDC	Bel(A)	□ / ■	Watts	rpm	°C	Hours	Hours	Hours	Curve
RLF 100-11/12	64	37,7	12	8...15	6,4	■	8,0	5 100	-20...+75	80 000 / 30 000		135 000	①
RLF 100-11/14	64	37,7	24	16...30	6,4	■	8,0	5 100	-20...+75	80 000 / 30 000		135 000	①
RLF 100-11/18	64	37,7	48	36...60	6,4	■	8,6	5 100	-20...+75	80 000 / 30 000		135 000	①
High speed models with Open Collector Tacho and PWM speed control.													
RLF 100-11/12/2 HP-200	80	47,1	12	10...13,2	7,5	■	18,6	6 400	-20...+60	72 500 / 45 000		122 500	②
RLF 100-11/18/2 HP-182	80	47,1	48	43...53	7,5	■	17,0	6 400	-20...+70	72 500 / 35 000		122 500	②

Subject to alternations

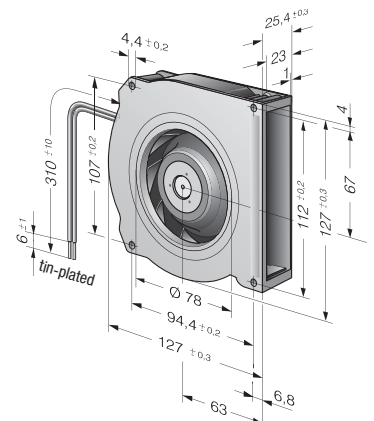
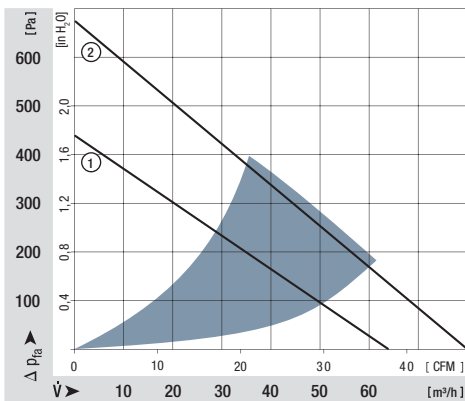

max. 55 m<sup>3</sup>/h

# DC centrifugal fans

Series RG 90 N 135 x 135 x 38 mm



- **Material:** Scroll housing: GRP<sup>1)</sup>  
Impeller: GRP<sup>1)</sup>  
Housing base: Sheet steel
  - **Direction of air flow:** Axial: Intake  
Centrifugal: Exhaust
  - **Connection:** Via single wires AWG 22, TR 64  
48 V model: Flat plug  
6.3 x 0.8 mm for protective earth
  - **Highlights:** Forwards-curved impeller
  - **Mass:** 440 g
- **Possible special versions:**  
(See chapter DC fans - specials)
    - Speed signal
    - Go / No-go alarm
    - Alarm with limit speed
    - External temperature sensor
    - Internal temperature sensor
    - PWM control input
    - Analogue control input
    - Protection against moisture
    - Protection against salt fog
    - Type of protection: IP 54 / IP 68

1) Fibreglass-reinforced plastic

Nominal data	Air flow		Nominal voltage	Voltage range		Sound power level	Sintec sleeve bearings Ball bearings	Input power	Nominal speed	Temperature range	Service life L <sub>10</sub> (40 °C) ebm-papst Standard	Service life L <sub>10</sub> (T <sub>max</sub> ) ebm-papst Standard	Life expectancy L <sub>10</sub> IPC (40 °C) see page 17	Curve
	m <sup>3</sup> /h	CFM		VDC	VDC									
RG 90-18/12 N	55	32,4	12	7...15	5,5	■	6,7	2 200	-30...+75	62 500 / 27 500	105 000	①		
RG 90-18/14 NG	55	32,4	24	12...28	5,5	□	6,2	2 200	-10...+75	62 500 / 27 500	105 000	①		
RG 90-18/14 N	55	32,4	24	12...28	5,5	■	6,2	2 200	-30...+75	62 500 / 27 500	105 000	①		
RG 90-18/18 N	55	32,4	48	36...56	5,5	■	6,1	2 200	-30...+75	62 500 / 27 500	105 000	①		

Subject to alternations

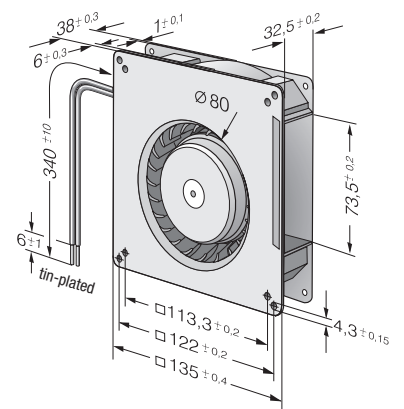
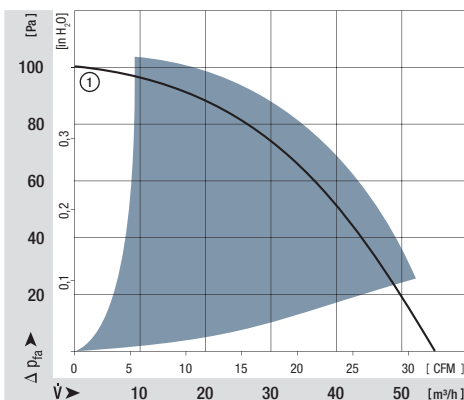

max. 137 m<sup>3</sup>/h

# DC centrifugal fans

Series RG 125 N 180 x 180 x 40 mm

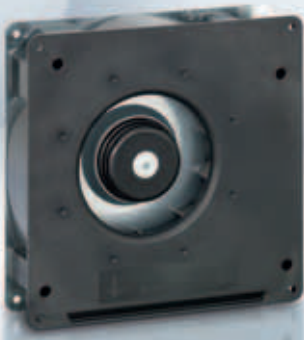

- **Material:** Scroll housing: GRP<sup>1)</sup>  
Impeller: GRP<sup>1)</sup>  
Housing base: Sheet steel
  - **Direction of air flow:** Axial: Intake  
Centrifugal: Exhaust
  - **Connection:** Via single wires AWG 22, TR 64  
48 V model: Flat plug  
6.3 x 0.8 mm for protective earth
  - **Highlights:** Backwards-curved impeller
  - **Mass:** 730 g
- **Possible special versions:**  
(See chapter DC fans - specials)
    - Speed signal
    - Go / No-go alarm
    - Alarm with limit speed
    - External temperature sensor
    - Internal temperature sensor
    - PWM control input
    - Analogue control input
    - Protection against moisture
    - Protection against salt fog
    - Type of protection: IP 54 / IP 68

1) Fibreglass-reinforced plastic

Nominal data	Air flow		Nominal voltage	Voltage range	Sound power level	Sinter sleeve bearings Ball bearings	Input power	Nominal speed	Temperature range	Service life L <sub>10</sub> (40 °C) ebm-papst Standard	Service life L <sub>10</sub> (T <sub>max</sub> ) ebm-papst Standard	Life expectancy L <sub>10</sub> (IPC (40 °C) see page 17	Curve
	m <sup>3</sup> /h	CFM											
RG 125-19/12 NM	60,0	35,3	12	7...15	4,8	■	2,0	1 750	-30...+75	70 000 / 30 000		117 500	①
RG 125-19/12 N	87,5	51,5	12	7...15	5,8	■	5,2	2 550	-30...+75	62 500 / 27 500		105 000	②
RG 125-19/14 NM	60,0	35,3	24	12...28	4,8	■	2,0	1 750	-30...+75	70 000 / 30 000		117 500	①
RG 125-19/14 N	87,5	51,5	24	12...28	5,8	■	4,9	2 550	-30...+75	62 500 / 27 500		105 000	②
RG 125-19/18 N	87,5	51,5	48	36...56	5,8	■	4,8	2 550	-30...+75	62 500 / 27 500		105 000	②
RG 125-19/18 NH	137	80,6	48	36...56	7,0	■	19,0	4 000	-20...+70	55 000 / 27 500		92 500	③

Subject to alternations

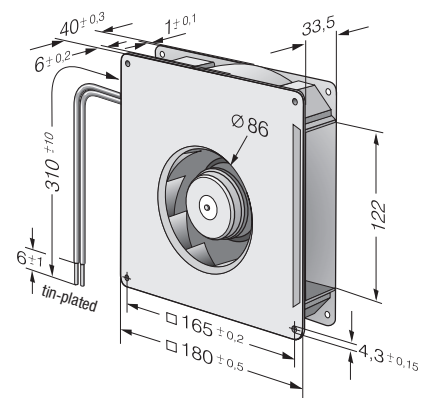
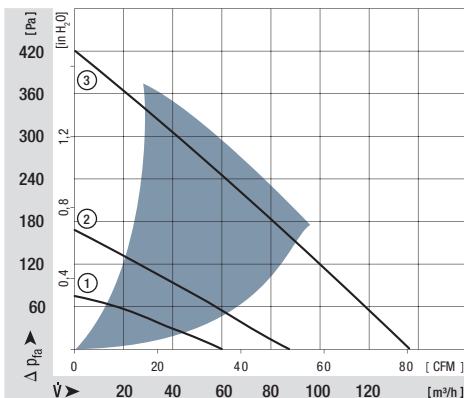



max. 209 m<sup>3</sup>/h

# DC centrifugal fans

Series RG 160 N 220 x 220 x 56 mm

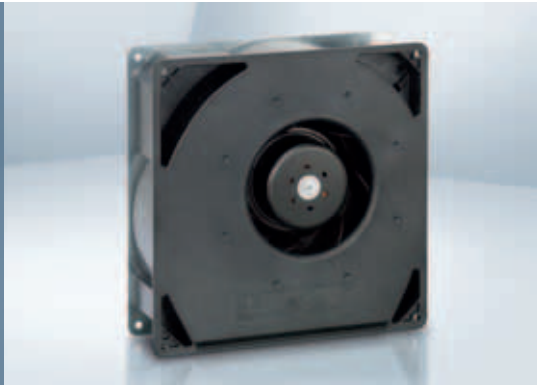

- **Material:** Scroll housing: GRP<sup>1)</sup>  
Impeller: GRP<sup>1)</sup>  
Housing base: Sheet steel
  - **Direction of air flow:** Axial: Intake  
Centrifugal: Exhaust
  - **Connection:** Via single wires AWG 22, TR 64  
48 V model: Flat plug  
6.3 x 0.8 mm for protective earth  
Backwards-curved impeller
  - **Highlights:**
  - **Mass:** 1,4 kg
- **Possible special versions:**  
(See chapter DC fans - specials)
    - Speed signal
    - Go / No-go alarm
    - Alarm with limit speed
    - External temperature sensor
    - Internal temperature sensor
    - PWM control input
    - Analogue control input
    - Protection against moisture
    - Protection against salt fog
    - Type of protection: IP 54

1) Fibreglass-reinforced plastic

Nominal data	Air flow		Nominal voltage	Voltage range		Sound power level	Sintec sleeve bearings Ball bearings	Input power	Nominal speed	Temperature range	Service life L <sub>10</sub> (40 °C) ebm-papst Standard	Service life L <sub>10</sub> (T <sub>max</sub> ) ebm-papst Standard	Life expectancy L <sub>10</sub> IPC (40 °C) see page 17	Curve
	m <sup>3</sup> /h	CFM		VDC	VDC									
RG 160-28/12 NM	139	81	12	7...14	5,6	■	7,5	1 900	-20...+70	80 000 / 40 000	135 000	①		
RG 160-28/12 N	209	123	12	7,5...14	6,6	■	21,0	2 850	-20...+70	70 000 / 35 000	117 500	②		
RG 160-28/14 NM	139	81	24	12...28	5,6	■	7,0	1 900	-20...+70	80 000 / 40 000	135 000	①		
RG 160-28/14 N	209	123	24	12...28	6,6	■	20,0	2 850	-20...+70	70 000 / 35 000	117 500	②		
RG 160-28/18 N	209	123	48	28...60	6,6	■	20,0	2 850	-20...+70	70 000 / 35 000	117 500	②		

Subject to alternations

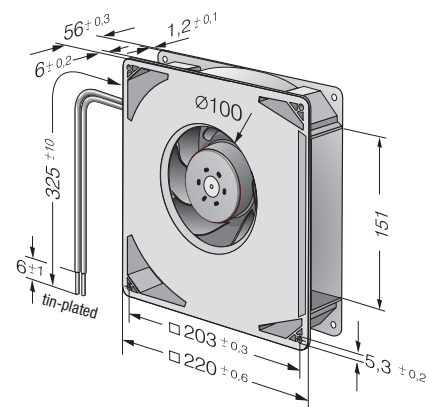
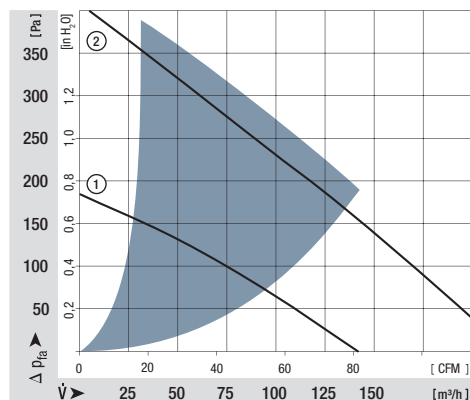

max. 444 m<sup>3</sup>/h

# DC centrifugal fans

Series RG 160 NTD 220 x 220 x 56 mm



- **Material:** Scroll housing: GRP<sup>1)</sup>  
Impeller: GRP<sup>1)</sup>  
Housing base: Sheet steel
  - **Direction of air flow:** Axial: Intake  
Centrifugal: Exhaust
  - **Connection:** Via single wires AWG 22, TR 64  
48 V model: Flat plug  
6.3 x 0.8 mm for protective earth
  - **Highlights:** 3-phase fan drive with very smooth running  
Backwards-curved impeller
  - **Mass:** 1,4 kg
- **Possible special versions:** (See chapter DC fans - specials)
    - Speed signal
    - Go / No-go alarm
    - Alarm with limit speed
    - External temperature sensor
    - Internal temperature sensor
    - PWM control input
    - Analogue control input
    - Protection against moisture
    - Type of protection: IP 54

<sup>1)</sup> Fibreglass-reinforced plastic

Nominal data		Air flow		Nominal voltage		Voltage range		Sound power level		Sinter sleeve bearings Ball bearings		Input power		Nominal speed		Temperature range		Service life L <sub>10</sub> (40 °C) ebm-papst Standard		Service life L <sub>10</sub> (T <sub>max</sub> ) ebm-papst Standard		Life expectancy L <sub>10</sub> (IPC (40 °C) see page 17		Curve		
Type		m <sup>3</sup> /h	CFM	VDC	VDC	Bel(A)	□ / ■	Watts	rpm	°C	Hours	Hours	Hours	Hours	Hours	Hours	Hours	Hours	Hours	Hours	Hours	Hours	Hours	Hours	Hours	Curve
min. max.	RG 160-28/14 NTD...	59	35	24	16...28	—	■	2,0	800	-20...+60	55 000 / 35 000	92 500	92 500	92 500	92 500	92 500	92 500	92 500	92 500	92 500	92 500	92 500	92 500	92 500	①	
		308	181			7,5	64,0	4 200	②																	
	RG 160-28/14 NTD	308	181	24	16...28	7,5	■	64,0	4 200	-20...+60	55 000 / 35 000	92 500	92 500	92 500	92 500	92 500	92 500	92 500	92 500	92 500	92 500	92 500	92 500	92 500	②	
	RG 160-28/14 NTDH	370	218	24	16...28	7,8	■	101,0	5 000	-20...+60	50 000 / 32 500	85 000	85 000	85 000	85 000	85 000	85 000	85 000	85 000	85 000	85 000	85 000	85 000	85 000	③	
min. max.	RG 160-28/18 NTD...	59	35	48	38...57	—	■	2,0	800	-20...+70	55 000 / 27 500	92 500	92 500	92 500	92 500	92 500	92 500	92 500	92 500	92 500	92 500	92 500	92 500	92 500	①	
		308	181			7,5	59,0	4 200	②																	
	RG 160-28/18/2 N/2 TDHHP*	444	261	48	36...60	8,5	■	159	6 000	-20...+65	40 000 / 22 500	67 500	67 500	67 500	67 500	67 500	67 500	67 500	67 500	67 500	67 500	67 500	67 500	67 500	④	

Subject to alternations

Models RG 160-28/14 NTD... and RG 160-28/18 NTD... are available in customer-specific, custom-developed variants only. The data specified here are technically feasible benchmark values. The fans can be specially adapted to your application with signal outputs and control inputs.

\*The specific service life is valid when an external capacitor is wired between the plus and minus wires. Please note the wiring suggestion.

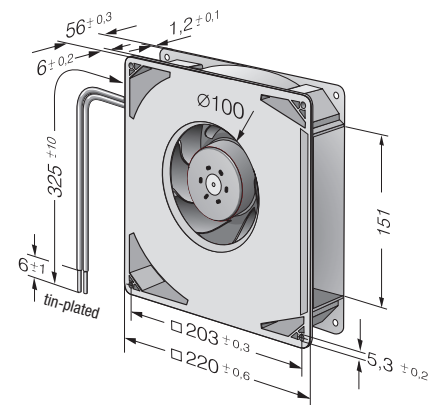
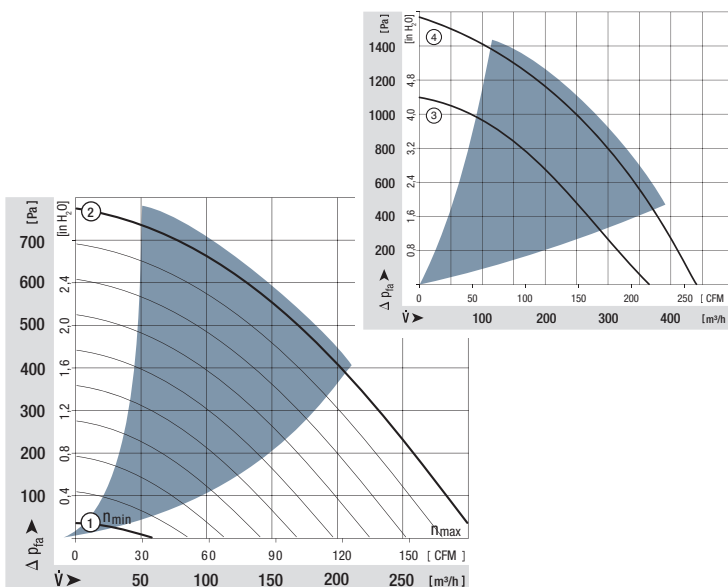

max. 930 m<sup>3</sup>/h  
**S-Force**

# DC centrifugal fans

Series RG 190 TD 225 x 225 x 85 mm

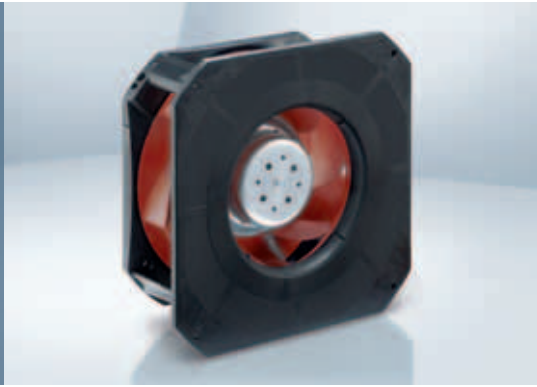

- **Material:** Scroll housing: GRP<sup>1)</sup>  
Impeller: GRP<sup>1)</sup>
- **Direction of air flow:** Axial: Intake, Centrifugal: Exhaust
- **Direction of rotation:** Clockwise, seen on rotor
- **Connection:** Via single wires AWG 18, 20 or AWG 22, TR 64, speed signal and control input AWG 22
- **Highlights:** 3-phase fan drive with very smooth running and high efficiency  
Backwards-curved RadiCal impeller
- **Mass:** 1210 g
- **Possible special versions:** (See chapter DC fans - specials)
  - Speed signal
  - Go / No-go alarm
  - Alarm with limit speed
  - External temperature sensor
  - Internal temperature sensor
  - PWM control input
  - Analogue control input
  - Multi-option control input
  - Protection against moisture
  - Protection against salt fog
  - Type of protection: IP 54

<sup>1)</sup> Fibreglass-reinforced plastic

Nominal data	Air flow		Nominal voltage	Voltage range		Sound power level	Sintec sleeve bearings Ball bearings	Input power	Nominal speed	Temperature range	Service life L <sub>10</sub> (40 °C) ebm-papst Standard	Service life L <sub>10</sub> (T <sub>max</sub> ) ebm-papst Standard	Life expectancy L <sub>10</sub> IPC (40 °C) see page 17	Curve
	m <sup>3</sup> /h	CFM		VDC	VDC									
RG 190-39/14/2 TDML0	630	371	24	16...30	7,6	■	54	3 000	-20...+60	55 000 / 35 000	92 500	①		
RG 190-39/14/2 TDMO	820	482	24	16...36	7,9	■	113	3 900	-20...+65	52 500 / 30 000	87 500	②		
RG 190-39/18/2 TDML0*	630	371	48	36...57	7,6	■	52	3 000	-20...+65	55 000 / 30 000	92 500	①		
RG 190-39/18/2 TDMO	820	482	48	36...72	7,9	■	113	3 900	-20...+65	52 500 / 30 000	87 500	②		
RG 190-39/18/2 TDO	930	547	48	36...72	8,3	■	140	4 400	-20...+65	40 000 / 22 500	67 500	③		

\* provisional  
Subject to alternations

Speed control range from 800 rpm at 7 % PWM up to nominal speed at > 90 % PWM. Standstill at 0 % PWM, standstill if control cable is interrupted.

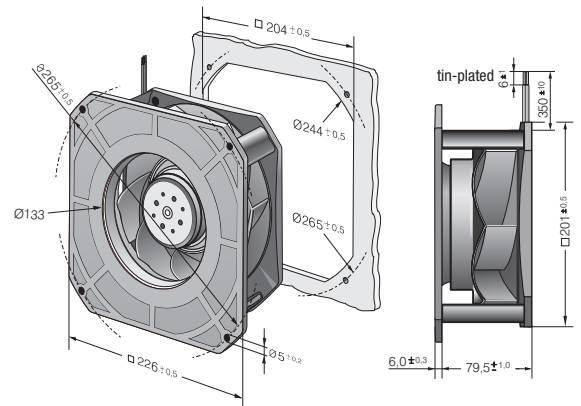
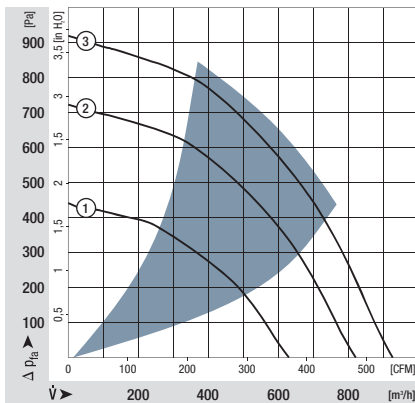

max. 1280 m<sup>3</sup>/h  
**S-Force**

## DC centrifugal fans

Series RG 220 TD 270 x 270 x 99 mm

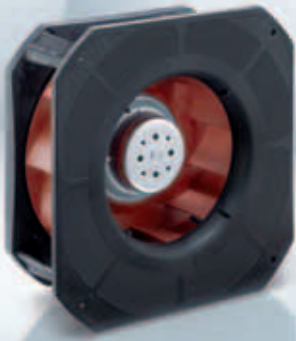

- **Material:** Scroll housing: GRP<sup>1)</sup>  
Impeller: GRP<sup>1)</sup>
- **Direction of air flow:** Axial: Intake  
Centrifugal: Exhaust
- **Direction of rotation:** Clockwise, seen on rotor
- **Connection:** Via single wires AWG 18, 20 or AWG 22, TR 64, speed signal and control input AWG 22
- **Highlights:** 3-phase fan drive with very smooth running and high efficiency  
Backwards-curved impeller
- **Mass:** 1870 g

- **Possible special versions:** (See chapter DC fans - specials)
  - Speed signal
  - Go / No-go alarm
  - Alarm with limit speed
  - External temperature sensor
  - Internal temperature sensor
  - PWM control input
  - Analogue control input
  - Protection against moisture
  - Protection against salt fog
  - Type of protection: IP 54

<sup>1)</sup> Fibreglass-reinforced plastic

Nominal data	Air flow		Nominal voltage	Voltage range	Sound power level	Sinter sleeve bearings Ball bearings	Input power	Nominal speed	Temperature range	Service life L <sub>10</sub> (40 °C) ebm-papst Standard	Service life L <sub>10</sub> (T max) ebm-papst Standard	Life expectancy L <sub>10</sub> (IPC (40 °C) see page 17	Curve
	m <sup>3</sup> /h	CFM											
RG 220-44/14/2 TDMO*	1090	641	24	16...36	7,7	■	82	3 000	-20...+55	75 000 / 52 500	127 500	92 500	①
RG 220-44/18/2 TDMO*	1090	641	48	36...72	7,7	■	80	3 000	-20...+55	75 000 / 52 500	127 500	92 500	①
RG 220-44/18/2 TDO*	1280	753	48	36...72	8,0	■	140	3 500	-20...+55	55 000 / 40 000	92 500	92 500	②

\* provisional

Subject to alternations

Speed control range from 800 rpm at 7 % PWM up to nominal speed at > 90 % PWM. Standstill at 0 % PWM, standstill if control cable is interrupted.

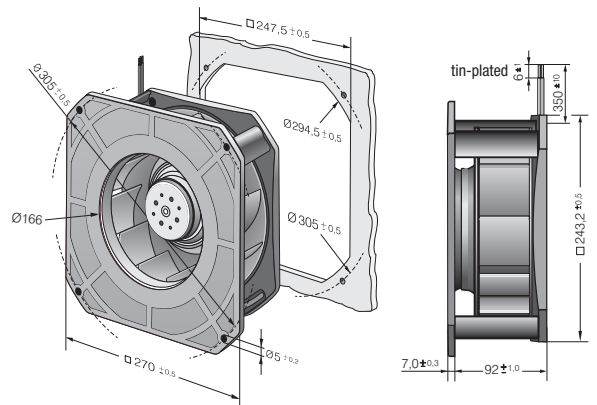
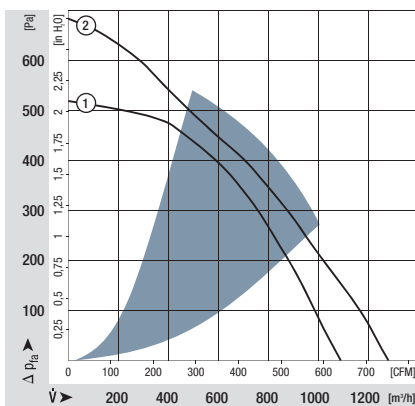

max. 1450 m<sup>3</sup>/h  
**S-Force**

# DC centrifugal fans

Series RG 225 TD 270 x 270 x 119 mm



- **Material:** Scroll housing: GRP<sup>1)</sup>  
Impeller: GRP<sup>1)</sup>
- **Direction of air flow:** Axial: Intake, Centrifugal: Exhaust
- **Direction of rotation:** Clockwise, seen on rotor
- **Connection:** Via single wires AWG 18, 20 or AWG 22, TR 64, speed signal and control input AWG 22
- **Highlights:** 3-phase fan drive with very smooth running and high efficiency  
Backwards-curved RadiCal impeller
- **Mass:** 1750 g
- **Possible special versions:** (See chapter DC fans - specials)
  - Speed signal
  - Go / No-go alarm
  - Alarm with limit speed
  - External temperature sensor
  - Internal temperature sensor
  - PWM control input
  - Analogue control input
  - Protection against moisture
  - Protection against salt fog
  - Type of protection: IP 54

<sup>1)</sup> Fibreglass-reinforced plastic

Nominal data	Air flow		Nominal voltage	Voltage range		Sound power level	Sinter sleeve bearings Ball bearings	Input power	Nominal speed	Temperature range	Service life L <sub>10</sub> (40 °C) ebm-papst Standard	Service life L <sub>10</sub> (T <sub>max</sub> ) ebm-papst Standard	Life expectancy L <sub>10</sub> IPC (40 °C) see page 17	Curve
	m <sup>3</sup> /h	CFM		VDC	VDC									
RG 225-55/14/2 TDMLO	1040	612	24	16...36	7,3	■	65	2 400	-20...+55	72 500 / 52 500	122 500	①		
RG 225-55/18/2 TDMLO*	1040	612	48	36...72	7,3	■	65	2 400	-20...+55	72 500 / 52 500	122 500	①		
RG 225-55/18/2 TDMO	1210	712	48	36...72	7,9	■	116	2 800	-20...+55	55 000 / 40 000	92 500	②		
NEW RG 225-55/18/2 TDO	1450	853	48	36...60	8,1	■	192	3 300	-20...+40	30 000 / 30 000	50 000	③		

\* provisional  
Subject to alternations

Speed control range from 800 rpm at 7 % PWM up to nominal speed at > 90 % PWM. Standstill at 0 % PWM, standstill if control cable is interrupted.  
The specific service life is valid when an external capacitor is wired between the plus and minus wires. Please note the wiring suggestion.

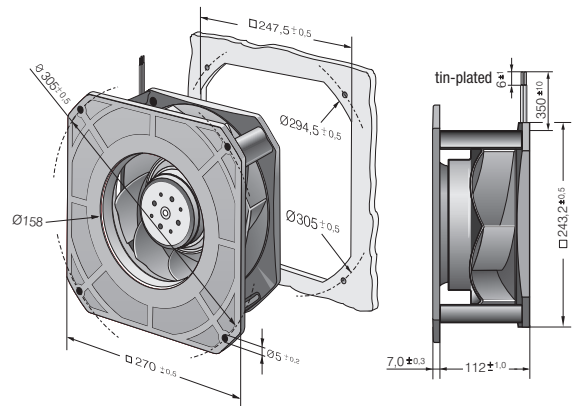
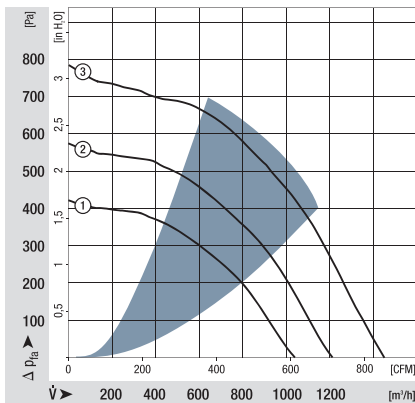

max. 220 m<sup>3</sup>/h  
**S-Force**

## DC centrifugal fans

Series RET 97 TD Ø 97 x 41 mm



- **Material:** Impeller: Galvanised sheet steel
- **Direction of air flow:** Axial: Intake, Centrifugal: Exhaust
- **Direction of rotation:** Clockwise, seen on rotor
- **Connection:** Via single wires AWG 18, 20 or AWG 22, TR 64, speed signal and control input AWG 22
- **Highlights:** 3-phase fan drive with very smooth running and high efficiency  
Forwards-curved impeller  
Fan requires a scroll housing
- **Mass:** 430 g
- **Possible special versions:** (See chapter DC fans - specials)
  - Speed signal
  - Go / No-go alarm
  - Alarm with limit speed
  - External temperature sensor
  - Internal temperature sensor
  - PWM control input
  - Analogue control input
  - Protection against moisture

Nominal data	Air flow	Air flow	Nominal voltage	Voltage range	Sound power level	Sinter sleeve bearings Ball bearings	Input power	Nominal speed	Temperature range	Service life L <sub>10</sub> (40 °C) ebm-papst Standard	Service life L <sub>10</sub> (T <sub>max</sub> ) ebm-papst Standard	Life expectancy L <sub>10</sub> (IPC (40 °C) see page 17	Curve
Type	m <sup>3</sup> /h	CFM	VDC	VDC	Bel(A)	□ / ■	Watts	rpm	°C	Hours	Hours	Hours	①
RET 97-25/14/2 TDP	220	129	24	16...36	8,1	■	77	6 000	-20...+60	80 000 / 50 000	135 000	135 000	①
RET 97-25/18/2 TDP	220	129	48	36...60	8,1	■	76	6 000	-20...+60	80 000 / 50 000	135 000	135 000	①

Subject to alternations

Speed control range from 800 rpm at 7 % PWM up to nominal speed at > 90 % PWM. Standstill at 0 % PWM, standstill if control cable is interrupted.

The specific service life is valid when an external capacitor is wired between the plus and minus wires.

Please note the wiring suggestion.

All nominal data were measured in the scroll housing.

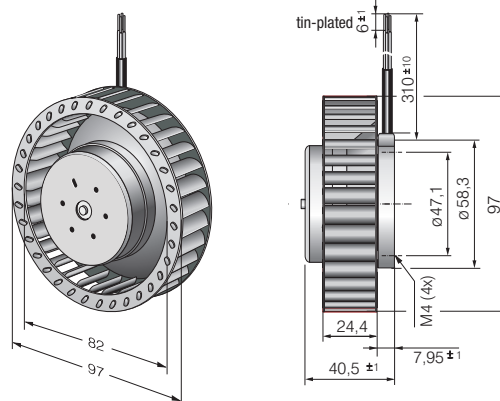
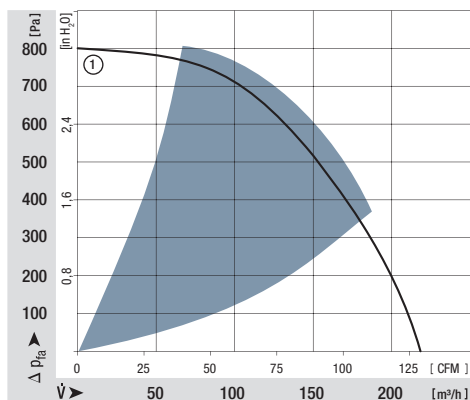



max. 104 m<sup>3</sup>/h

# DC centrifugal fans

Series REF 100 Ø 104 x 25 mm



- **Material:** Impeller: GRP<sup>1)</sup>
  - **Direction of air flow:** Axial: Intake  
Centrifugal: Exhaust
  - **Direction of rotation:** Clockwise, seen on rotor
  - **Connection:** Via single wires AWG 22, TR 64
  - **Highlights:** Backwards-curved impeller
  - **Mass:** 160 g
- **Possible special versions:** (See chapter DC fans - specials)
    - Speed signal
    - Go / No-go alarm
    - Alarm with limit speed
    - External temperature sensor
    - Internal temperature sensor
    - PWM control input
    - Analogue control input
    - Protection against moisture
    - Type of protection: IP 54

1) Fibreglass-reinforced plastic

Nominal data	Air flow		Nominal voltage	Voltage range	Sound power level	Sinter sleeve bearings Ball bearings	Input power	Nominal speed	Temperature range	Service life L <sub>10</sub> (40 °C) ebm-papst Standard	Service life L <sub>10</sub> (T <sub>max</sub> ) ebm-papst Standard	Life expectancy L <sub>10</sub> IPC (40 °C) see page 17	Curve
	m <sup>3</sup> /h	CFM											
REF 100-11/12	86	50,6	12	8...15	6,3	■	7,5	5 400	-20...+75	80 000 / 30 000	135 000	①	
REF 100-11/14	86	50,6	24	16...30	6,3	■	7,5	5 400	-20...+75	80 000 / 30 000	135 000	①	
REF 100-11/18	86	50,6	48	36...60	6,3	■	8,2	5 400	-20...+75	80 000 / 30 000	135 000	①	
REF 100-11/18 H	104	61,2	48	36...56	6,9	■	14,8	6 700	-20...+70	67 500 / 32 500	115 000	②	

Subject to alternations

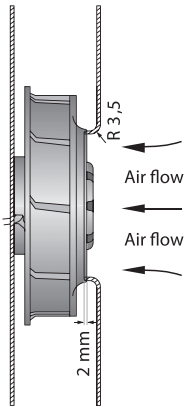

The air flow and noise level of the centrifugal fans without external housing depend on their individual installation conditions. The stated air flow and noise level were recorded under the following measurement parameters:  
Centrifugal fan mounted on a foundation plate 127 x 127 mm.  
Cover plate 127 x 127 mm, with an air inlet opening Ø 70 mm, arranged concentrically to the impeller.

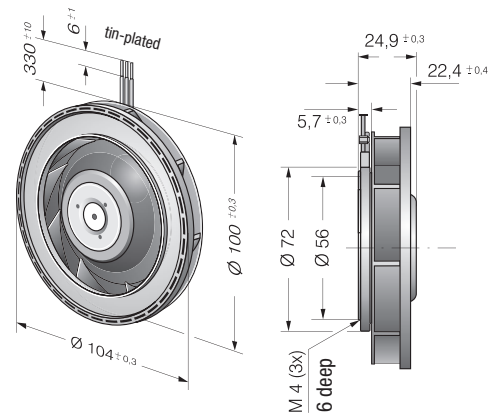
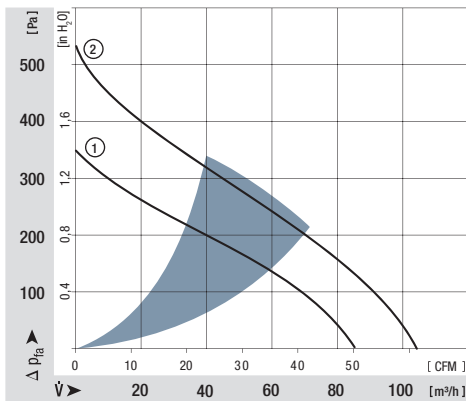

max. 190 m<sup>3</sup>/h

# DC centrifugal fans

Series RER 101 Ø 101 x 52 mm



- **Material:** Impeller: GRP<sup>1)</sup>
  - **Direction of air flow:** Axial: Intake  
Centrifugal: Exhaust
  - **Direction of rotation:** Clockwise, seen on rotor
  - **Connection:** Via single wires AWG 22, TR 64
  - **Highlights:** Backwards-curved impeller
  - **Mass:** 305 g
- **Possible special versions:**  
(See chapter DC fans - specials)
    - Speed signal
    - Go / No-go alarm
    - Alarm with limit speed
    - External temperature sensor
    - Internal temperature sensor
    - PWM control input
    - Analogue control input
    - Protection against moisture

1) Fibreglass-reinforced plastic

Nominal data	Air flow	Air flow	Nominal voltage	Voltage range	Sound power level	Sintec sleeve bearings Ball bearings	Input power	Nominal speed	Temperature range	Service life L <sub>10</sub> (40 °C) ebm-papst Standard	Service life L <sub>10</sub> (T <sub>max</sub> ) ebm-papst Standard	Life expectancy L <sub>10</sub> IPC (40 °C) see page 17	Curve
Type	m <sup>3</sup> /h	CFM	VDC	VDC	Bel(A)	□ / ■	Watts	rpm	°C	Hours	Hours	Hours	
RER 101-36/12 NH	162	95	12	9...13,6	6,9	■	13,0	5 000	-20...+70	65 000 / 32 500	110 000	②	
RER 101-36/12 NHH	190	112	12	9...13,6	7,2	■	20,5	6 000	-20...+70	60 000 / 30 000	102 500	①	
RER 101-36/14 NHH	190	112	24	18...27,2	7,2	■	22,5	6 050	-20...+70	60 000 / 30 000	102 500	①	
RER 101-36/18 NHH	190	112	48	36...60	7,2	■	19,4	5 850	-20...+70	60 000 / 30 000	102 500	①	

Subject to alternations

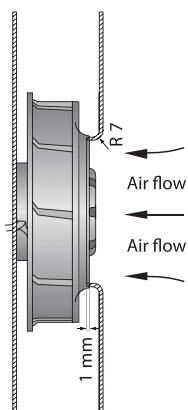

The air flow and noise level of the centrifugal fans without external housing depend on their individual installation conditions. The stated air flow and noise level were recorded under the following measurement parameters:  
Centrifugal fan mounted on a foundation plate 148 x 148 mm.  
Cover plate 148 x 148 mm, with an air inlet opening Ø 66 mm, arranged concentrically to the impeller.

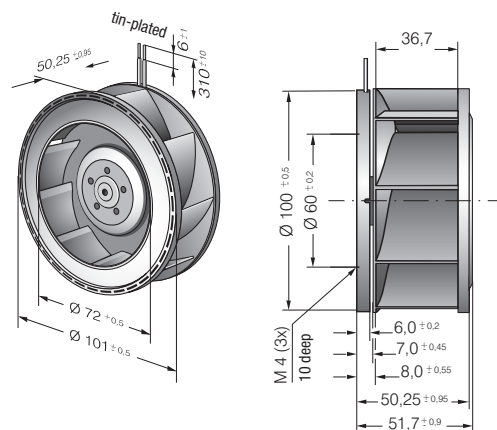
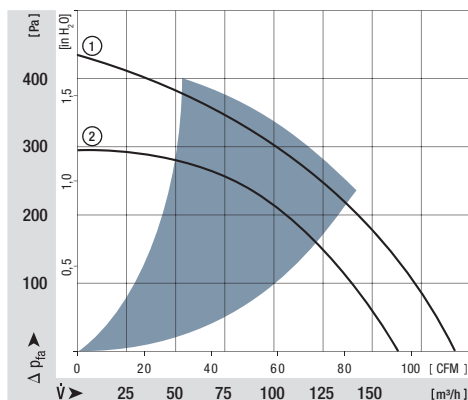

max. 390 m<sup>3</sup>/h  
**S-Force**

# DC centrifugal fans

Series RER 120 TD Ø 120 x 54 mm



- **Material:** Impeller: GRP<sup>1)</sup>
- **Direction of air flow:** Axial: Intake  
Centrifugal: Exhaust
- **Direction of rotation:** Clockwise, seen on rotor
- **Connection:** Via single wires AWG 18, 20 or AWG 22, TR 64, speed signal and control input AWG 22
- **Highlights:** 3-phase fan drive with very smooth running and high efficiency  
Backwards-curved impeller
- **Mass:** 430 g

1) Fibreglass-reinforced plastic

Nominal data	Air flow		Nominal voltage	Voltage range		Sound power level	Sinter sleeve bearings Ball bearings	Input power	Nominal speed	Temperature range	Service life L <sub>10</sub> (40 °C) ebm-papst Standard	Service life L <sub>10</sub> (T <sub>max</sub> ) ebm-papst Standard	Life expectancy L <sub>10</sub> IPC (40 °C) see page 17	Curve
	m <sup>3</sup> /h	CFM		VDC	VDC									
RER 120-26/14/2 TDMP*	320	188	24	16...32	tbd	■	51	5 200	-20...+60		60 000 / 37 500	102 500	①	
RER 120-26/14/2 TDP	377	222	24	16...32	8,2	■	78	6 100	-20...+60		55 000 / 35 000	92 500	②	
RER 120-26/18/2 TDMP*	320	188	48	36...60	tbd	■	51	5 200	-20...+60		57 500 / 35 000	97 500	①	
RER 120-26/18/2 TDP	390	230	48	36...60	8,3	■	92	6 300	-20...+60		50 000 / 30 000	85 000	③	

\* provisional  
Subject to alternations

Speed control range from 800 rpm at 7 % PWM up to nominal speed at > 90 % PWM. Standstill at 0 % PWM, standstill if control cable is interrupted.  
The specific service life is valid when an external capacitor is wired between the plus and minus wires.  
Please note the wiring suggestion.

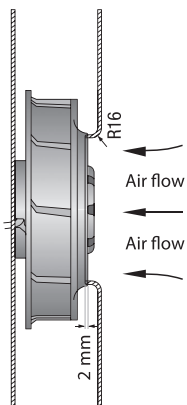

The air flow and noise level of the centrifugal fans without external housing depend on their individual installation conditions. The stated air flow and noise level were recorded under the following measurement parameters:  
Centrifugal fan mounted on a foundation plate 140 x 140 mm.  
Cover plate 140 x 140 mm, with an air inlet opening Ø 94,4 mm, arranged concentrically to the fan impeller.

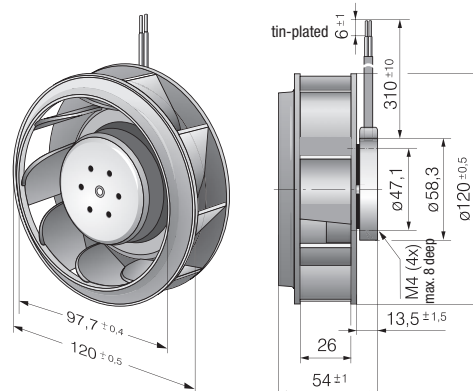
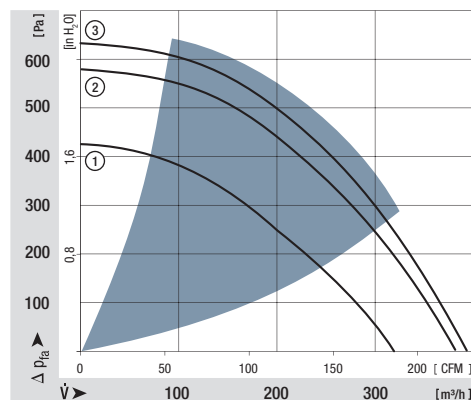

max. 250 m<sup>3</sup>/h

# DC centrifugal fans

Ø 120 mm



- **Material:** Impeller: PA 6.6 plastic, fibreglass-reinforced  
Rotor: Galvanised
- **Number of blades:** 9
- **Direction of rotation:** Clockwise, seen on rotor
- **Type of protection:** IP 20
- **Insulation class:** "B"
- **Mounting position:** Any
- **Condensate discharges:** None
- **Operation mode:** Continuous operation (S1)
- **Bearings:** Maintenance-free ball bearings

Nominal data		Curve	Nominal voltage	Voltage range	Air flow	Speed / rpm	Input power	Current draw	Sound power level	Perm. amb. temp.	Technical features and electrical connections
Type	Motor	VDC	VDC	m <sup>3</sup> /h	rpm	W	A	dB(A)	°C		
<b>R1G 120</b>	M1G 045-BE	Ⓐ	24	16-28	250	4060	26	1,20	62	-25..+60	p. 255 / G)
<b>R1G 120</b>	M1G 045-BE	Ⓐ	48	36-57	250	4060	26	0,60	62	-25..+60	p. 255 / G)

Subject to alternations

**Curve:**

U<sub>N</sub> = nominal voltage  
(24 V / 48 V)

U<sub>R</sub> = overvoltage  
(28 V / 57 V)

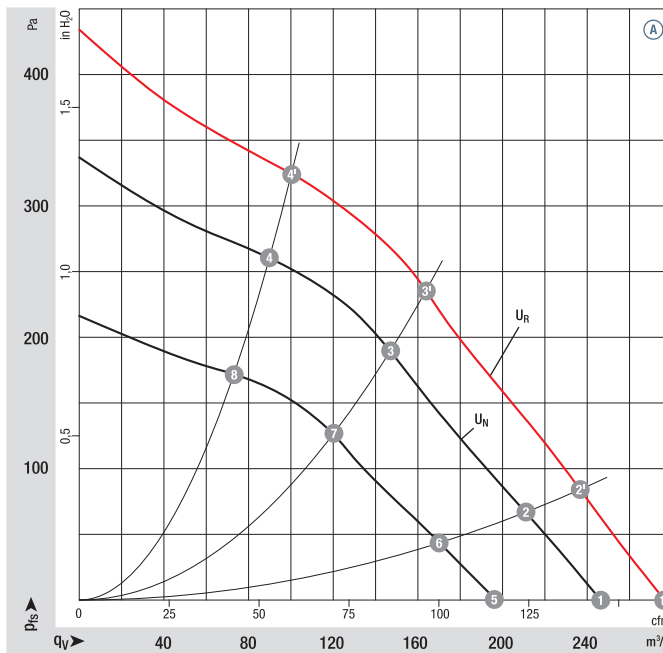

	n rpm	P <sub>ed</sub> W	L <sub>pA</sub> dB(A)	η <sub>IL</sub> %
Ⓐ 1'	4520	36	65	—
Ⓐ 2'	4500	36	64	27
Ⓐ 3'	4540	36	61	45
Ⓐ 4'	4750	32	64	39
Ⓐ 1	4060	26	62	—
Ⓐ 2	4000	26	61	27
Ⓐ 3	4050	26	58	45
Ⓐ 4	4200	23	61	39
Ⓐ 5	3270	14	56	—
Ⓐ 6	3250	14	55	27
Ⓐ 7	3280	14	53	45
Ⓐ 8	3400	13	56	39

Air performance measured as per: ISO 5801, Installation category A, with ebm-papst inlet nozzle without protection against accidental contact. Suction-side noise levels: LWA as per ISO 13347, LpA measured at 1 m distance to fan axis. The acoustic values given are only valid under the measurement conditions listed and may vary depending on the installation situation. With any deviation to the standard setup, the specific values have to be checked and reviewed once installed or fitted! For detailed information see <http://www.ebmpapst.com/general-conditions>

- **Technical features:** See electrical connections p. 255
- **Cable exit:** Axial
- **Protection class:** I
- **Product conforming to standards:** EN 60950-1
- **Approvals:** Ⓐ (48 VDC) CCC

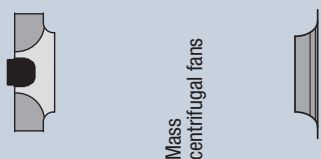

Mass centrifugal fans

Centrifugal fans	kg	Inlet nozzle (long)
R1G 120-AD13 -02	0,5	96120-2-4013
R1G 120-AD11 -02	0,5	96120-2-4013

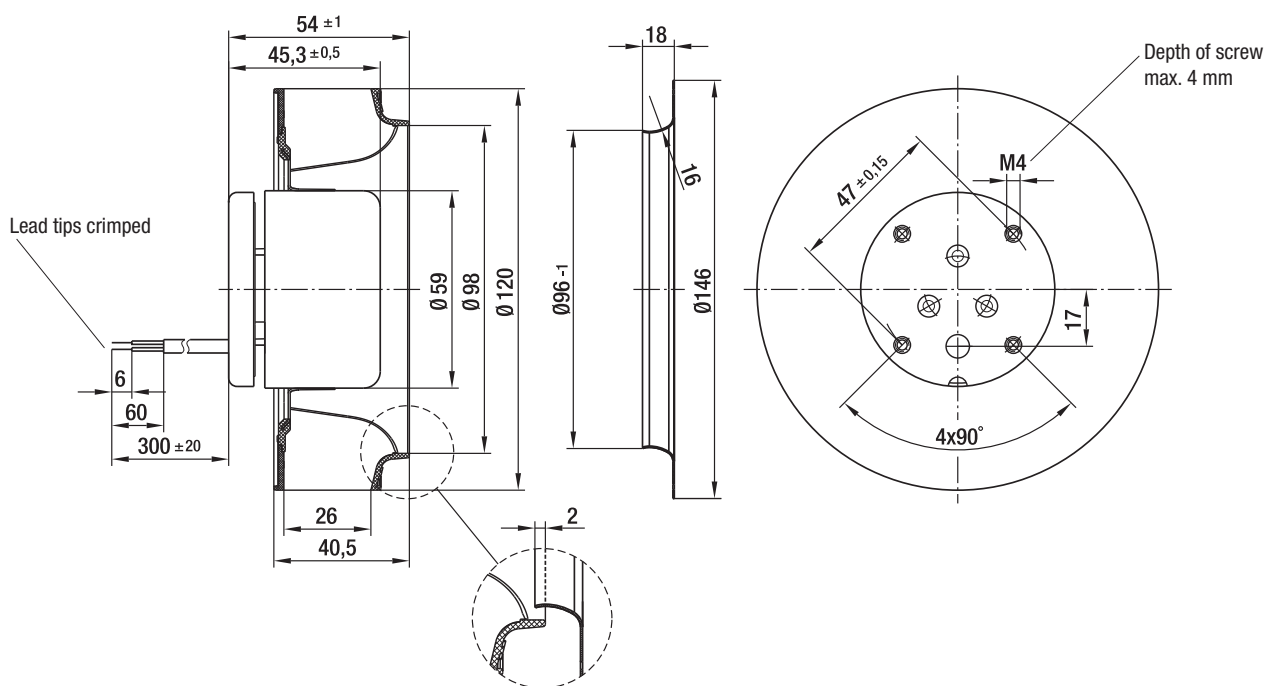

max. 166 m<sup>3</sup>/h

# DC centrifugal fans

Series RER 125 N Ø 138 x 35 mm



- **Material:** Impeller: GRP<sup>1)</sup>
  - **Direction of air flow:** Axial: Intake  
Centrifugal: Exhaust
  - **Direction of rotation:** Clockwise, seen on rotor
  - **Connection:** Via single wires AWG 22, TR 64
  - **Highlights:** Backwards-curved impeller
  - **Mass:** 320 g
- **Possible special versions:**  
(See chapter DC fans - specials)
    - Speed signal
    - Go / No-go alarm
    - Alarm with limit speed
    - External temperature sensor
    - Internal temperature sensor
    - PWM control input
    - Analogue control input
    - Protection against moisture
    - Protection against salt fog
    - Type of protection: IP 54 / IP 68

1) Fibreglass-reinforced plastic

Nominal data	Air flow	Air flow	Nominal voltage	Voltage range	Sound power level	Sinter sleeve bearings Ball bearings	Input power	Nominal speed	Temperature range	Service life L <sub>10</sub> (40 °C) ebm-papst Standard	Service life L <sub>10</sub> (T <sub>max</sub> ) ebm-papst Standard	Life expectancy L <sub>10</sub> (IPC (40 °C) see page 17	Curve
Type	m <sup>3</sup> /h	CFM	VDC	VDC	Bel(A)	■ / ■	Watts	rpm	°C	Hours	Hours	Hours	Curve
RER 125-19/12 N	110	64,7	12	7...15	5,7	■	4,6	2 650	-30...+75	62 500 / 27 500	105 000	105 000	①
RER 125-19/14 N	110	64,7	24	12...28	5,7	■	4,3	2 650	-30...+75	62 500 / 27 500	105 000	105 000	①
RER 125-19/14 NH	166	97,7	24	12...28	7,0	■	13,0	4 000	-20...+70	55 000 / 27 500	92 500	92 500	②
RER 125-19/18 N	110	64,7	48	36...56	5,7	■	4,2	2 650	-30...+75	62 500 / 27 500	105 000	105 000	①

Subject to alternations

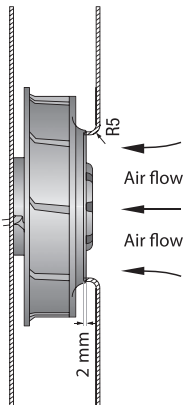

The air flow and noise level of the centrifugal fans without external housing depend on their individual installation conditions. The stated air flow and noise level were recorded under the following measurement parameters:  
Centrifugal fan mounted on a foundation plate 120 x 120 mm.  
Cover plate 120 x 120 mm, with an air inlet opening Ø 86 mm, arranged concentrically to the impeller.

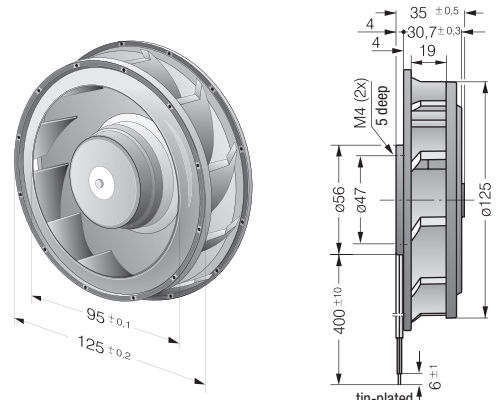
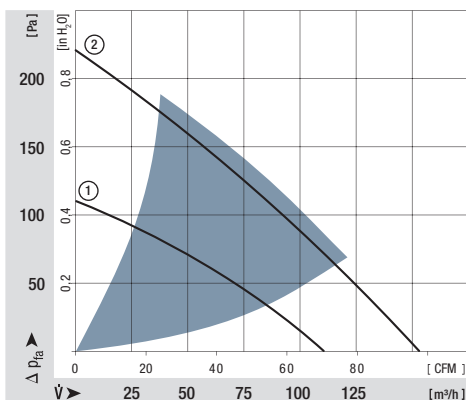



max. 565 m<sup>3</sup>/h  
**S-Force**

# DC centrifugal fans

Series RER 133 TD Ø 133 x 91 mm



- **Material:** Impeller: GRP<sup>1)</sup>
  - **Direction of air flow:** Axial: Intake  
Centrifugal: Exhaust
  - **Direction of rotation:** Clockwise, seen on rotor
  - **Connection:** Via single wires AWG 18, 20 or AWG 22, TR 64, speed signal and control input AWG 22
  - **Highlights:** 3-phase fan drive with very smooth running and high efficiency  
Backwards-curved impeller
  - **Mass:** 890 g
- Possible special versions:**  
(See chapter DC fans - specials)
- Speed signal
  - Go / No-go alarm
  - Alarm with limit speed
  - External temperature sensor
  - Internal temperature sensor
  - PWM control input
  - Analogue control input
  - Multi-option control input
  - Protection against moisture
  - Protection against salt fog
  - Type of protection: IP 54

1) Fibreglass-reinforced plastic

Nominal data	Air flow		Nominal voltage	Voltage range		Sound power level	Sintec sleeve bearings Ball bearings	Input power	Nominal speed	Temperature range	Service life L <sub>10</sub> (40 °C) ebm-papst Standard	Service life L <sub>10</sub> (T <sub>max</sub> ) ebm-papst Standard	Life expectancy L <sub>10</sub> IPC (40 °C) see page 17	Curve
	m <sup>3</sup> /h	CFM		VDC	VDC									
RER 133-41/14/2 TDMP	460	271	24	16...30	tbd	■	58	5 000	-20...+65	72 500 / 40 000	122 500	①		
RER 133-41/14/2 TDP*	565	332	24	16...36	tbd	■	90	6 000	-20...+65	70 000 / 37 500	117 500	②		
RER 133-41/18/2 TDMP*	460	271	48	36...57	tbd	■	50	5 000	-20...+65	72 500 / 40 000	122 500	①		
RER 133-41/18/2 TDP	565	332	48	36...72	8,2	■	87	6 000	-20...+65	70 000 / 37 500	117 500	②		

\* provisional  
Subject to alterations

Speed control range from 800 rpm at 7 % PWM up to nominal speed at > 90 % PWM. Standstill at 0 % PWM, standstill if control cable is interrupted.

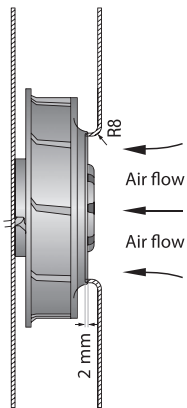

The air flow and noise level of the centrifugal fans without external housing depend on their individual installation conditions. The stated air flow and noise level were recorded under the following measurement parameters:  
Centrifugal fan mounted on a foundation plate 140 x 140 mm. Cover plate 140 x 140 mm, with an air inlet opening Ø 87 mm, arranged concentrically to the impeller.

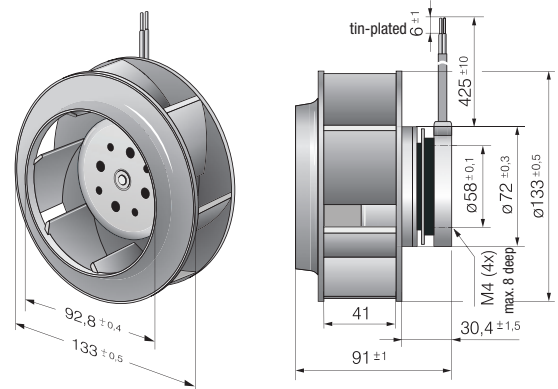
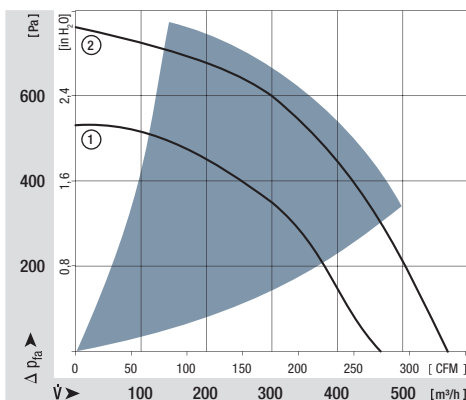

max. 255 m<sup>3</sup>/h

# DC centrifugal fans

Series RER 160 N Ø 165 x 51 mm



- **Material:** Impeller: GRP<sup>1)</sup>
  - **Direction of air flow:** Axial: Intake  
Centrifugal: Exhaust
  - **Direction of rotation:** Counter-clockwise, seen on rotor
  - **Connection:** Via single wires AWG 22, TR 64
  - **Highlights:** Backwards-curved impeller
  - **Mass:** 590 g
- **Possible special versions:**  
(See chapter DC fans - specials)
    - Speed signal
    - Go / No-go alarm
    - Alarm with limit speed
    - External temperature sensor
    - Internal temperature sensor
    - PWM control input
    - Analogue control input
    - Protection against moisture
    - Protection against salt fog
    - Type of protection: IP 54

1) Fibreglass-reinforced plastic

Nominal data	Air flow		Nominal voltage	Voltage range	Sound power level	Sinter sleeve bearings Ball bearings	Input power	Nominal speed	Temperature range	Service life L <sub>10</sub> (40 °C) ebm-papst Standard	Service life L <sub>10</sub> (T max) ebm-papst Standard	Life expectancy L <sub>10</sub> (IPC (40 °C) see page 17	Curve
	m <sup>3</sup> /h	CFM											
RER 160-28/12 N	255	150	12	7...14	6,4	■	19,0	3 000	-20...+70	75 000 / 37 500	127 500	①	
RER 160-28/14 N	255	150	24	12...28	6,4	■	19,0	3 000	-20...+70	75 000 / 37 500	127 500	①	
RER 160-28/18 N	255	150	48	28...60	6,4	■	19,0	3 000	-20...+70	75 000 / 37 500	127 500	①	

Subject to alternations

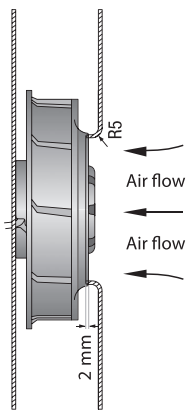

The air flow and noise level of the centrifugal fans without external housing depend on their individual installation conditions. The stated air flow and noise level were recorded under the following measurement parameters:  
Centrifugal fan mounted on a foundation plate 260 x 260 mm.  
Cover plate 260 x 260 mm, with an air inlet opening Ø 100 mm, arranged concentrically to the impeller.

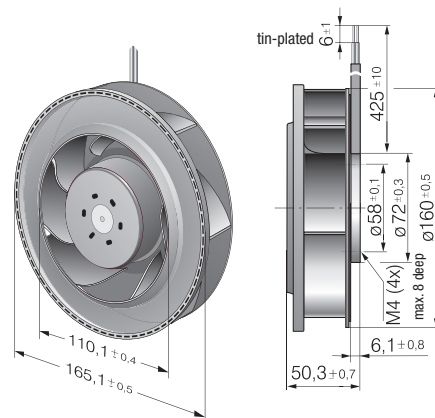
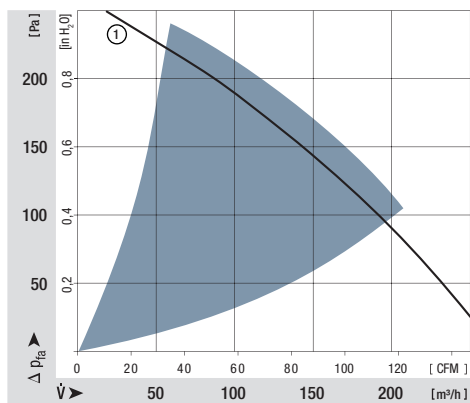

max. 370 m<sup>3</sup>/h  
**S-Force**

# DC centrifugal fans

Series RER 160 NTD Ø 165 x 51 mm



- **Material:** Impeller: GRP<sup>1)</sup>
- **Direction of air flow:** Axial: Intake  
Centrifugal: Exhaust
- **Direction of rotation:** Clockwise, seen on rotor
- **Connection:** Via single wires AWG 22, TR 64
- **Highlights:** 3-phase fan drive with very smooth running and high efficiency  
Backwards-curved impeller
- **Mass:** 590 g
- **Possible special versions:** (See chapter DC fans - specials)
  - Speed signal
  - Go / No-go alarm
  - Alarm with limit speed
  - External temperature sensor
  - Internal temperature sensor
  - PWM control input
  - Analogue control input
  - Protection against moisture
  - Type of protection: IP 54

1) Fibreglass-reinforced plastic

Nominal data	Air flow		Nominal voltage	Voltage range		Sound power level	Sinter sleeve bearings Ball bearings	Input power	Nominal speed	Temperature range	Service life L <sub>10</sub> (40 °C) ebm-papst Standard	Service life L <sub>10</sub> (T <sub>max</sub> ) ebm-papst Standard	Life expectancy L <sub>10</sub> IPC (40 °C) see page 17	Curve
	m <sup>3</sup> /h	CFM		VDC	VDC									
RER 160-28/14 N/2 TDA	370	217	24	16...28	7,4	■	51	4 200	-20...+60	55 000 / 35 000	92 500	②		
RER 160-28/18 N/2 TDHHP*	305	298	48	36...60	8,5	■	142	6 000	-20...+65	40 000 / 22 500	67 500	③		
min. max.	RER 160-28/18 NTD...	66	39	48	38...57	—	2,0	800	-20...+70	55 000 / 27 500	92 500	①		
		354	98				43,0	4 200					②	

Subject to alternations

Model RER 160-28/18 NTD... is available in customer-specific, custom-developed variant only. The data specified here are technically feasible benchmark values. The fans can be specially adapted to your application with signal outputs and control inputs.  
\* The specific service life is valid when an external capacitor is wired between the plus and minus wires. Please note the wiring suggestion.

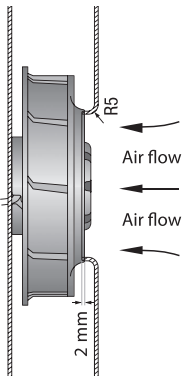

The air flow and noise level of the centrifugal fans without external housing depend on their individual installation conditions. The stated air flow and noise level were recorded under the following measurement parameters:  
Centrifugal fan mounted on a foundation plate 260 x 260 mm. Cover plate 260 x 260 mm, with an air inlet opening Ø 100 mm, arranged concentrically to the impeller.

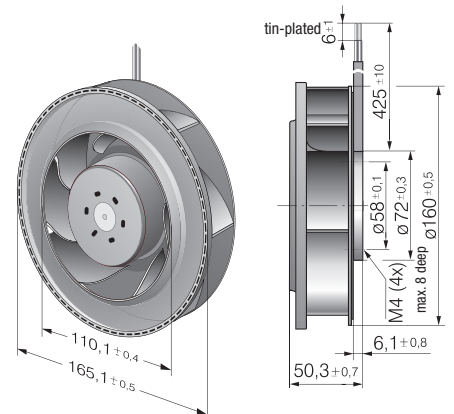
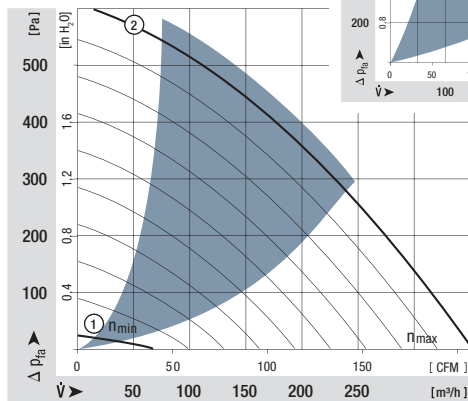
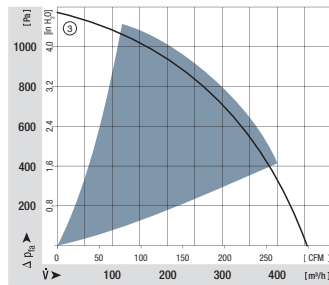

Information  
DC axial fans  
DC centrifugal fans  
DC fans - specials  
ACmaxx / GreenTech EC-Compact fans  
AC axial fans  
AC centrifugal fans  
Accessories  
Representatives

max. 800 m<sup>3</sup>/h  
**S-Force**

# DC centrifugal fans

Series REF 175 TD Ø 175 x 55 mm



- **Material:** Impeller: Galvanised sheet steel
  - **Direction of air flow:** Axial: Intake, Centrifugal: Exhaust
  - **Direction of rotation:** Clockwise, seen on rotor
  - **Connection:** Via single wires AWG 18, 20 or AWG 22, TR 64, speed signal and control input AWG 22
  - **Highlights:** 3-phase fan drive with very smooth running and high efficiency  
Backwards-curved impeller
  - **Mass:** 930 g
- **Possible special versions:** (See chapter DC fans - specials)
    - Speed signal
    - Go / No-go alarm
    - Alarm with limit speed
    - External temperature sensor
    - Internal temperature sensor
    - PWM control input
    - Analogue control input
    - Multi-option control input
    - Protection against moisture
    - Type of protection: IP 54

1) Fibreglass-reinforced plastic

Nominal data	Air flow		Nominal voltage	Voltage range	Sound power level	Sintec sleeve bearings Ball bearings	Input power	Nominal speed	Temperature range	Service life L <sub>10</sub> (40 °C) ebm-papst Standard	Service life L <sub>10</sub> (T max) ebm-papst Standard	Life expectancy L <sub>10</sub> IPC (40 °C) see page 17	Curve
	m <sup>3</sup> /h	CFM											
REF 175-30/18/2 TDP	800	470	48	36 ... 72	8,3	■ / ■	144	4 400	-20...+60	65 000 / 37 500		110 000	①

Subject to alternations

Speed control range from 800 rpm at 7 % PWM up to nominal speed at > 90 % PWM. Standstill at 0 % PWM, standstill if control cable is interrupted.

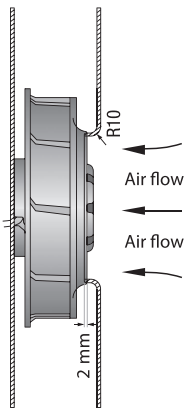

The air flow and noise level of the centrifugal fans without external housing depend on their individual installation conditions. The stated air flow and noise level were recorded under the following measurement parameters:  
Centrifugal fan mounted on a foundation plate 180 x 180 mm.  
Cover plate 180 x 180 mm, with an air inlet opening Ø 125,5 mm, arranged concentrically to the impeller.

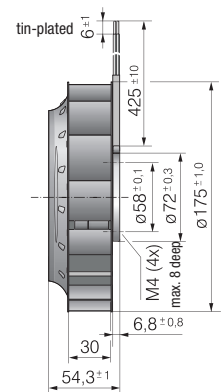
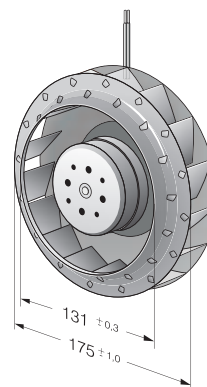
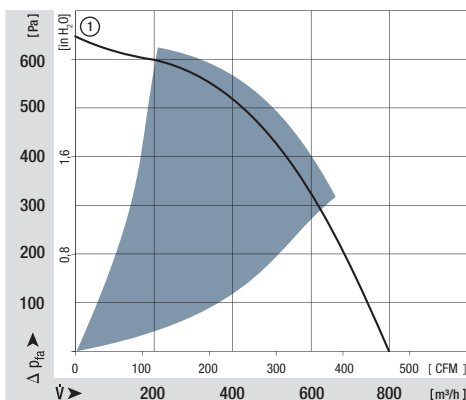

max. 980 m<sup>3</sup>/h  
**S-Force**

# DC centrifugal fans

Series RER 175 TD Ø 175 x 69 mm



- **Material:** Impeller: GRP<sup>1)</sup>
  - **Direction of air flow:** Axial: Intake  
Centrifugal: Exhaust
  - **Direction of rotation:** Clockwise, seen on rotor
  - **Connection:** Via single wires AWG 18, 20 or AWG 22, TR 64, speed signal and control input AWG 22
  - **Highlights:** 3-phase fan drive with very smooth running and high efficiency  
Backwards-curved impeller
  - **Mass:** 775 g
- Possible special versions:**  
(See chapter DC fans - specials)
- Speed signal
  - Go / No-go alarm
  - Alarm with limit speed
  - External temperature sensor
  - Internal temperature sensor
  - PWM control input
  - Analogue control input
  - Multi-option control input
  - Protection against moisture
  - Protection against salt fog
  - Type of protection: IP 54

1) Fibreglass-reinforced plastic

Nominal data	Air flow		Nominal voltage	Voltage range		Sound power level	Sinter sleeve bearings Ball bearings	Input power	Nominal speed	Temperature range	Service life L <sub>10</sub> (40 °C) ebm-papst Standard	Service life L <sub>10</sub> (T <sub>max</sub> ) ebm-papst Standard	Life expectancy L <sub>10</sub> IPC (40 °C) see page 17	Curve
	m <sup>3</sup> /h	CFM		VDC	VDC									
RER 175-42/14/2 TDMLP	600	353	24	16...30	7,3	■	48	3 400	-20...+65	72 500 / 40 000	122 500	①		
RER 175-42/14/2 TDMP	865	509	24	16...36	8,2	■	110	4 800	-20...+65	70 000 / 40 000	117 500	②		
RER 175-42/18/2 TDMLP	600	353	48	36...57	7,3	■	46	3 400	-20...+65	72 500 / 40 000	122 500	①		
RER 175-42/18/2 TDMP*	865	509	48	36...72	8,2	■	110	4 800	-20...+65	70 000 / 40 000	117 500	②		
RER 175-42/18/2 TDP	980	577	48	36...72	8,5	■	166	5 400	-20...+65	60 000 / 32 500	102 500	③		

\* vorläufig

Subject to alternations

Speed control range from 800 rpm at 7 % PWM up to nominal speed at > 90 % PWM. Standstill at 0 % PWM, standstill if control cable is interrupted.

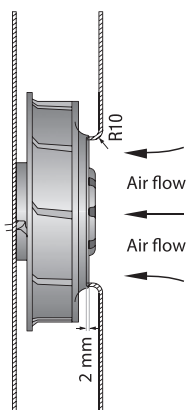

The air flow and noise level of the centrifugal fans without external housing depend on their individual installation conditions. The stated air flow and noise level were recorded under the following measurement parameters:  
Centrifugal fan mounted on a foundation plate 180 x 180 mm.  
Cover plate 180 x 180 mm, with an air inlet opening Ø 125,5 mm, arranged concentrically to the impeller.

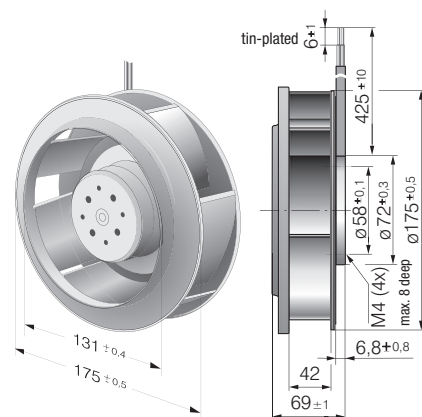
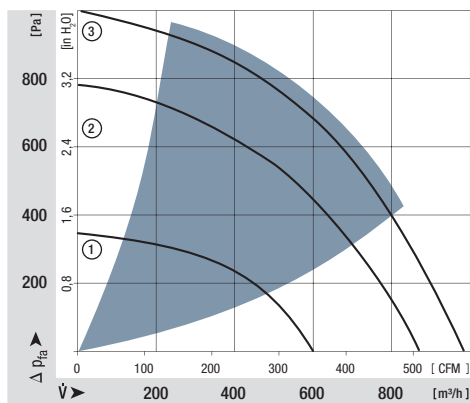



max. 970 m<sup>3</sup>/h  
**S-Force**

# DC centrifugal fans

Series RER 190 TD Ø 190 x 69 mm



- **Material:** Impeller: GRP<sup>1)</sup>
- **Direction of air flow:** Axial: Intake, Centrifugal: Exhaust
- **Direction of rotation:** Clockwise, seen on rotor
- **Connection:** Via single wires AWG 18, 20 or AWG 22, TR 64, speed signal and control input AWG 22
- **Highlights:** 3-phase fan drive with very smooth running and high efficiency  
Backwards-curved RadiCal impeller
- **Mass:** 870 g
- **Possible special versions:** (See chapter DC fans - specials)
  - Speed signal
  - Go / No-go alarm
  - Alarm with limit speed
  - External temperature sensor
  - Internal temperature sensor
  - PWM control input
  - Analogue control input
  - Multi-option control input
  - Protection against moisture
  - Protection against salt fog
  - Type of protection: IP 54

<sup>1)</sup> Fibreglass-reinforced plastic

Nominal data	Air flow		Nominal voltage	Voltage range	Sound power level	Sintec sleeve bearings Ball bearings	Input power	Nominal speed	Temperature range	Service life L <sub>10</sub> (40 °C) ebm-papst Standard	Service life L <sub>10</sub> (T max) ebm-papst Standard	Life expectancy L <sub>10</sub> (IPC (40 °C) see page 17	Curve
	m <sup>3</sup> /h	CFM											
RER 190-39/14/2 TDML0	650	382	24	16...30	7,6	■	58	3 000	-20...+60	55 000 / 35 000		92 500	①
RER 190-39/14/2 TDM0	860	506	24	16...36	7,9	■	110	3 900	-20...+65	52 500 / 30 000		87 500	②
RER 190-39/18/2 TDML0*	650	382	48	36...57	7,6	■	56	3 000	-20...+65	55 000 / 30 000		92 500	①
RER 190-39/18/2 TDM0*	860	506	48	36...72	7,9	■	105	3 900	-20...+65	52 500 / 30 000		87 500	②
RER 190-39/18/2 TD0	970	571	48	36...72	8,3	■	148	4 400	-20...+65	40 000 / 22 500		67 500	③

\* Auf Anfrage  
Subject to alternations

Speed control range from 800 rpm at 7 % PWM up to nominal speed at > 90 % PWM. Standstill at 0 % PWM, standstill if control cable is interrupted.

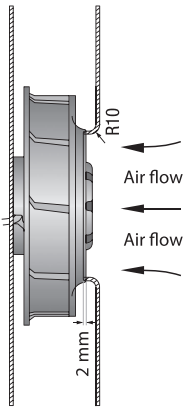

The air flow and noise level of the centrifugal fans without external housing depend on their individual installation conditions. The stated air flow and noise level were recorded under the following measurement parameters:  
Centrifugal fan mounted on a foundation plate 195 x 195 mm.  
Cover plate 195 x 195 mm, with an air inlet opening Ø 125,5 mm, arranged concentrically to the impeller.

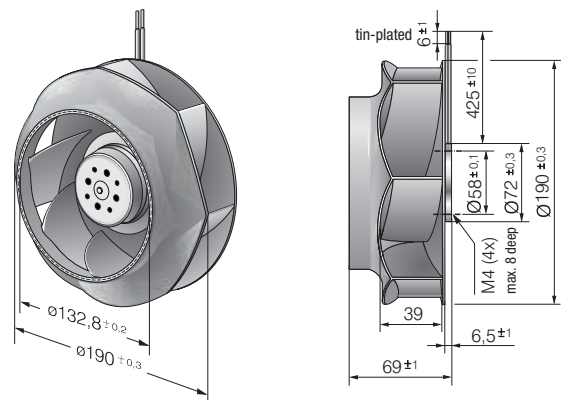
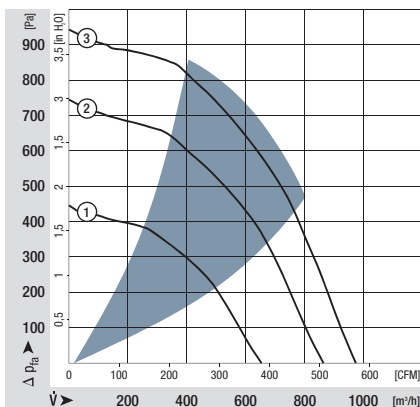





max. 930 m<sup>3</sup>/h

# DC centrifugal fans – RadiCal

Ø 190 mm

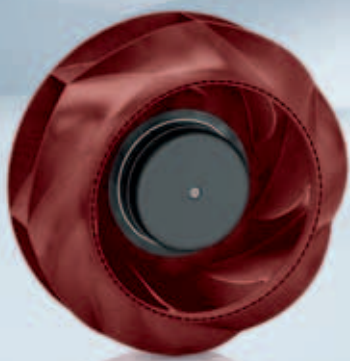

- **Material:** Impeller: Plastic PA  
Rotor: Coated in black
- **Number of blades:** 7
- **Direction of rotation:** Clockwise, seen on rotor
- **Type of protection:** IP 44, depending on installation and position
- **Insulation class:** "B"
- **Mounting position:** Any
- **Condensate discharges:** None
- **Operation mode:** Continuous operation (S1)
- **Bearings:** Maintenance-free ball bearings

Nominal data		Curve	Nominal voltage	Voltage range	Air flow	Speed / rpm	Input power	Current draw	Sound power level	Perm. amb. temp.	Technical features and electrical connections
Type	Motor	VDC	VDC	m <sup>3</sup> /h	rpm	W	A	dB(A)	°C		
<b>R3G 190</b>	M3G 074-CF	Ⓐ	24	16-28	880	4570	180	7,50	76	-25..+60	p. 258 / J5)
<b>R3G 190</b>	M3G 074-CF	Ⓑ	48	36-57	930	4800	192	4,00	76	-25..+60	p. 258 / J5)

Subject to alternations

Curve:

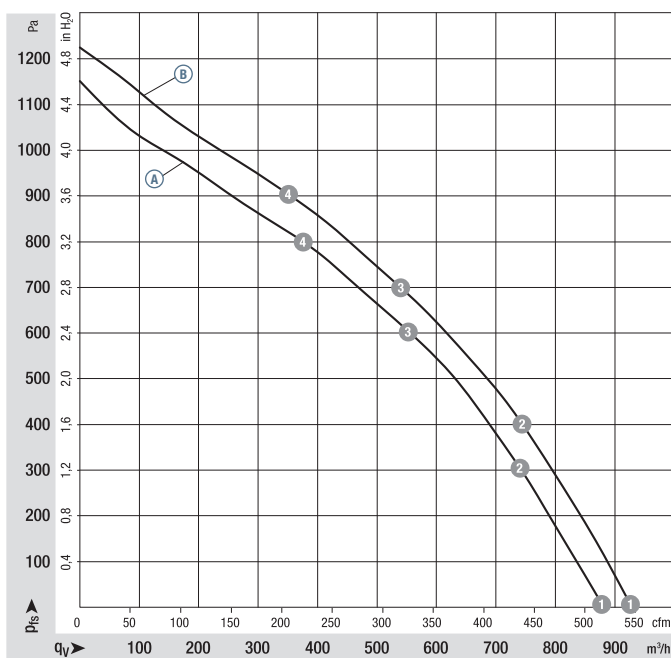

	n rpm	P <sub>ed</sub> W	I A	L <sub>WA</sub> dB(A)
Ⓐ 1	4570	180	7,50	84
Ⓐ 2	4525	188	7,83	79
Ⓐ 3	4435	199	8,34	77
Ⓐ 4	4520	191	7,96	81
Ⓑ 1	4800	192	4,00	84
Ⓑ 2	4690	212	4,41	80
Ⓑ 3	4640	221	4,60	79
Ⓑ 4	4740	205	4,28	81

Air performance measured as per: ISO 5801, Installation category A, with ebm-papst inlet nozzle without protection against accidental contact. Suction-side noise levels: LWA as per ISO 13347, LpA measured at 1 m distance to fan axis. The acoustic values given are only valid under the measurement conditions listed and may vary depending on the installation situation. With any deviation to the standard setup, the specific values have to be checked and reviewed once installed or fitted! For detailed information see <http://www.ebmpapst.com/general-conditions>

- **Technical features:** See electrical connections p. 258
- **Cable exit:** Variabel
- **Product conforming to standards:** EN 60950-1
- **Approvals:** GOST



Mass centrifugal fans



Centrifugal fans	kg	Inlet nozzle
R3G 190-RN38 -01	1,9	09576-2-4013
R3G 190-RN99 -02	1,9	09576-2-4013

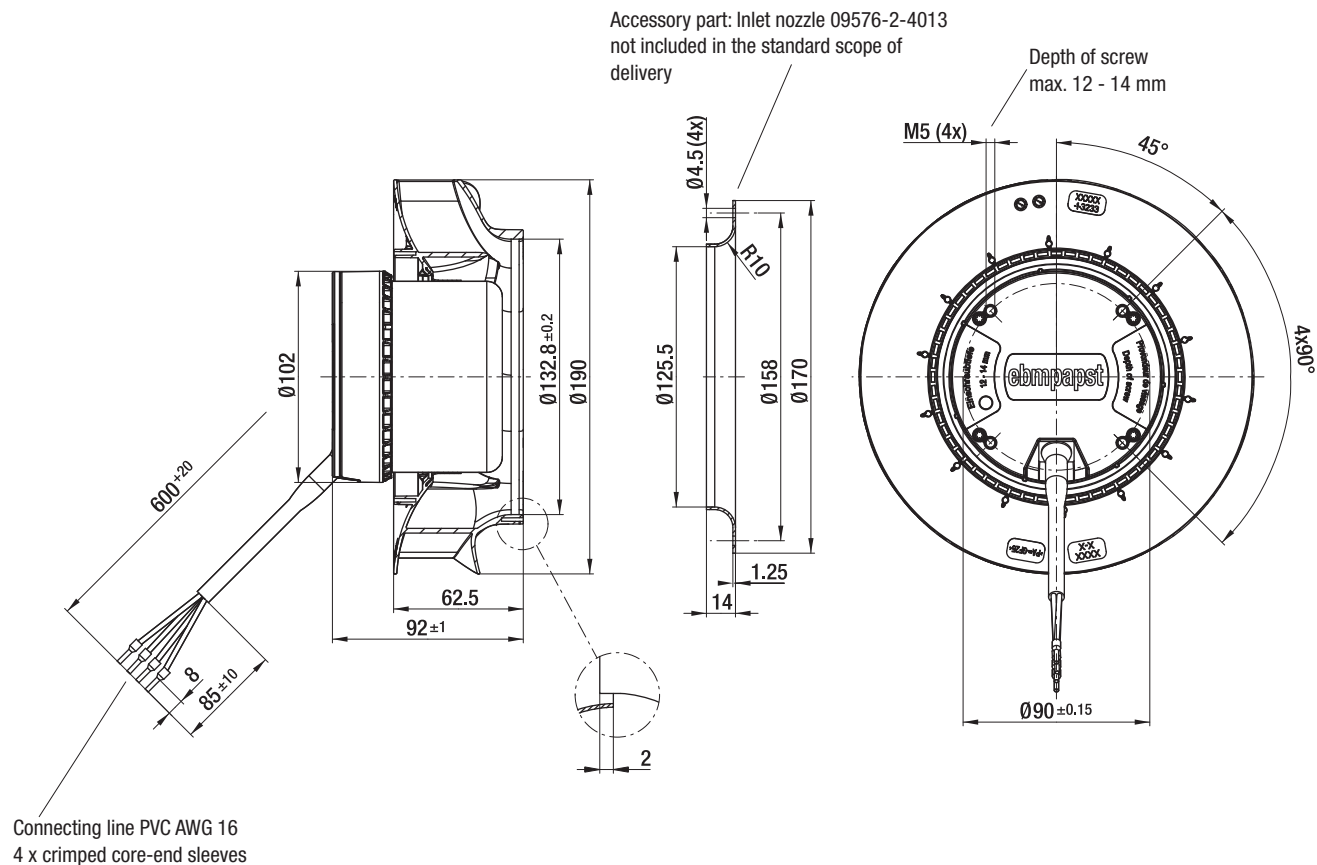

max. 1210 m<sup>3</sup>/h

# DC centrifugal fans – RadiCal

Ø 220 mm



- **Material:** Impeller: Plastic PA  
Rotor: Coated in black
- **Number of blades:** 7
- **Direction of rotation:** Clockwise, seen on rotor
- **Type of protection:** IP 44, depending on installation and position
- **Insulation class:** "B"
- **Mounting position:** Any
- **Condensate discharges:** None
- **Operation mode:** Continuous operation (S1)
- **Bearings:** Maintenance-free ball bearings

Nominal data		Curve	Nominal voltage	Voltage range	Air flow	Speed / rpm	Input power	Current draw	Sound power level	Perm. amb. temp.	Technical features and electrical connections
Type	Motor	VDC	VDC	m <sup>3</sup> /h	rpm	W	A	dB(A)	°C		
<b>R3G 220</b>	M3G 074-CF	Ⓐ	24	16-28	1185	3480	162	6,75	73	-25...+60	p. 258 / J5)
<b>R3G 220</b>	M3G 074-CF	Ⓑ	48	36-57	1210	3510	160	3,40	73	-25...+60	p. 258 / J5)

Subject to alternations

Curve:

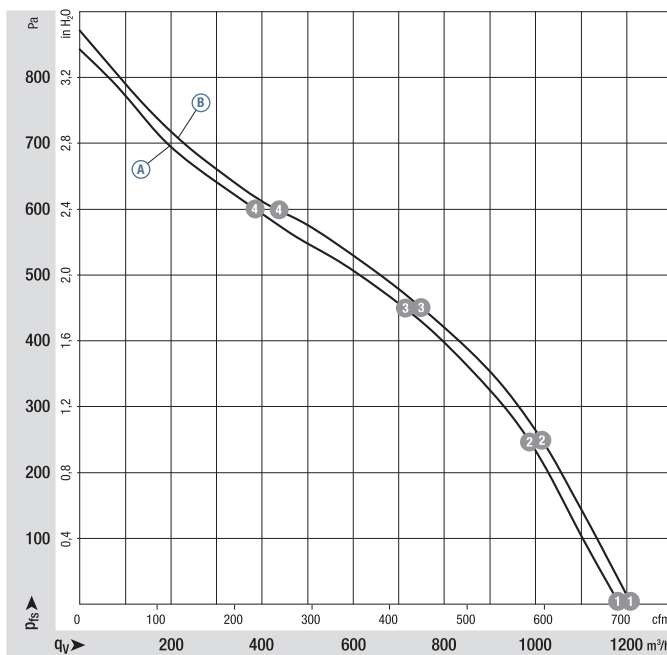

	n rpm	P <sub>ed</sub> W	I A	L <sub>WA</sub> dB(A)
Ⓐ 1	3480	162	6,75	81
Ⓐ 2	3420	171	7,11	77
Ⓐ 3	3360	182	7,59	74
Ⓐ 4	3455	168	6,97	79
Ⓑ 1	3510	160	3,40	81
Ⓑ 2	3450	168	3,50	77
Ⓑ 3	3385	178	3,71	74
Ⓑ 4	3460	167	3,47	79

Air performance measured as per: ISO 5801, Installation category A, with ebm-papst inlet nozzle without protection against accidental contact. Suction-side noise levels: LWA as per ISO 13347, LpA measured at 1 m distance to fan axis. The acoustic values given are only valid under the measurement conditions listed and may vary depending on the installation situation. With any deviation to the standard setup, the specific values have to be checked and reviewed once installed or fitted! For detailed information see <http://www.ebmpapst.com/general-conditions>

- **Technical features:** See electrical connections p. 258
- **Cable exit:** Variabel
- **Product conforming to standards:** EN 60950-1
- **Approvals:** GOST



Mass centrifugal fans



Centrifugal fans	kg	Inlet nozzle
R3G 220-RN12 -01	1,9	09609-2-4013
R3G 220-RNB6 -02	1,9	09609-2-4013

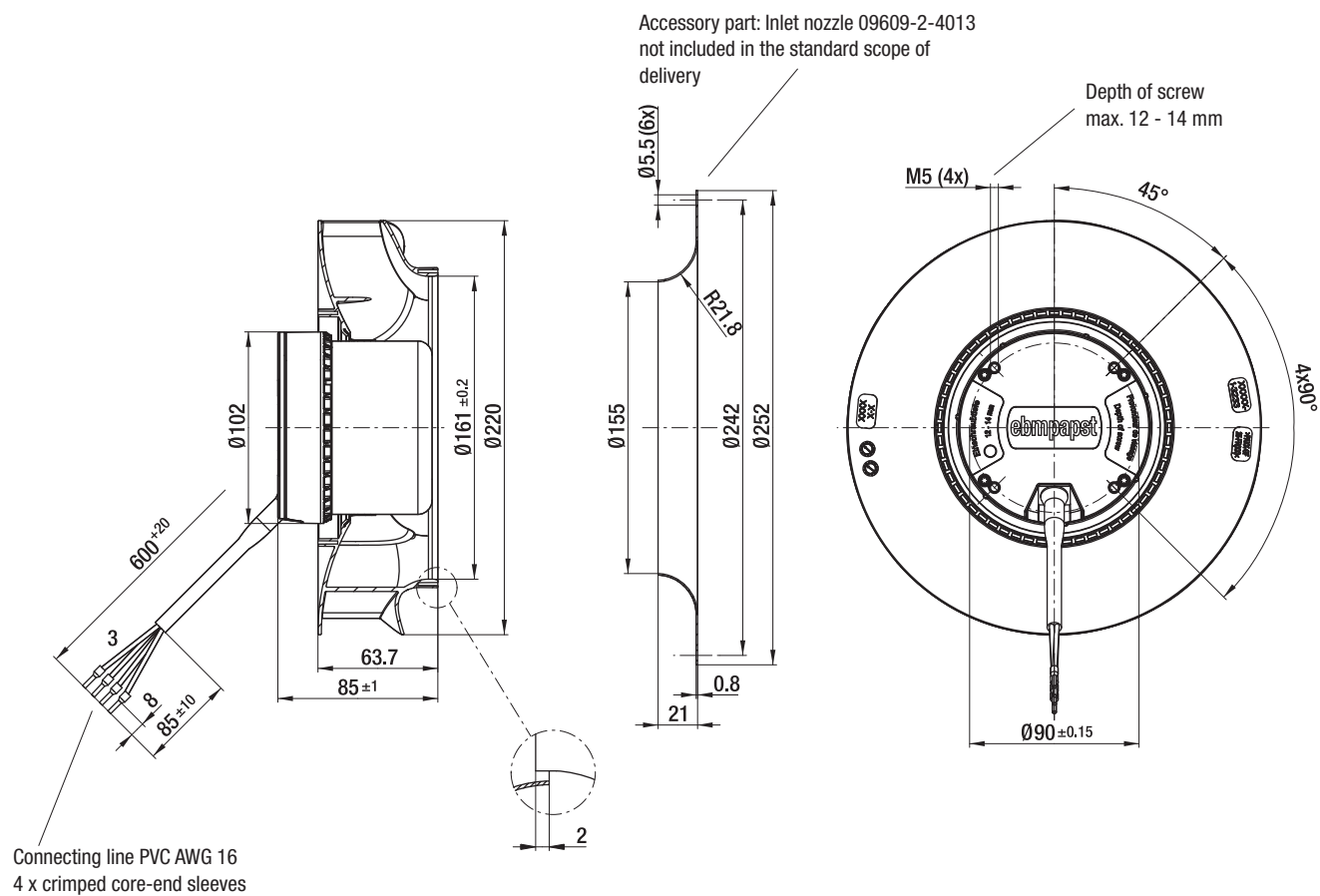

max. 1280 m<sup>3</sup>/h  
**S-Force**

# DC centrifugal fans

Series RER 220 TD Ø 221 x 71 mm



- **Material:** Impeller: GRP<sup>1)</sup>
- **Direction of air flow:** Axial: Intake  
Centrifugal: Exhaust
- **Direction of rotation:** Clockwise, seen on rotor
- **Connection:** Via single wires AWG 18, 20 or AWG 22, TR 64, speed signal and control input AWG 22
- **Highlights:** 3-phase fan drive with very smooth running and high efficiency  
Backwards-curved impeller
- **Mass:** 940 g
- **Possible special versions:** (See chapter DC fans - specials)
  - Speed signal
  - Go / No-go alarm
  - Alarm with limit speed
  - External temperature sensor
  - Internal temperature sensor
  - PWM control input
  - Analogue control input
  - Multi-option control input
  - Protection against moisture
  - Protection against salt fog
  - Type of protection: IP 54

1) Fibreglass-reinforced plastic

Nominal data	Air flow		Nominal voltage	Voltage range		Sound power level	Sinter sleeve bearings Ball bearings	Input power	Nominal speed	Temperature range	Service life L <sub>10</sub> (40 °C) ebm-papst Standard	Service life L <sub>10</sub> (T <sub>max</sub> ) ebm-papst Standard	Life expectancy L <sub>10</sub> IPC (40 °C) see page 17	Curve
	m <sup>3</sup> /h	CFM		VDC	VDC									
RER 220-44/14/2 TDM0*	1090	641	24	16...36	7,7	■	82	3 000	-20...+55	75 000 / 52 500	127 500	①		
RER 220-44/18/2 TDM0*	1090	641	48	36...72	7,7	■	80	3 000	-20...+55	75 000 / 52 500	127 500	①		
RER 220-44/18/2 TDP	1280	753	48	36...72	8,0	■	140	3 500	-20...+55	55 000 / 40 000	92 500	②		

\* upon request  
Subject to alternations

Speed control range from 800 rpm at 7 % PWM up to nominal speed at > 90 % PWM. Standstill at 0 % PWM, standstill if control cable is interrupted.

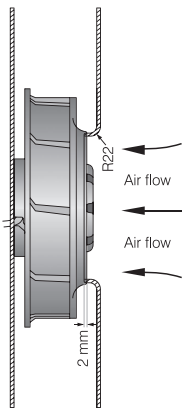

The air flow and noise level of the centrifugal fans without external housing depend on their individual installation conditions. The stated air flow and noise level were recorded under the following measurement parameters:  
Centrifugal fan mounted on a foundation plate 230 x 230 mm.  
Cover plate 230 x 230 mm, with an air inlet opening Ø 155 mm, arranged concentrically to the impeller.

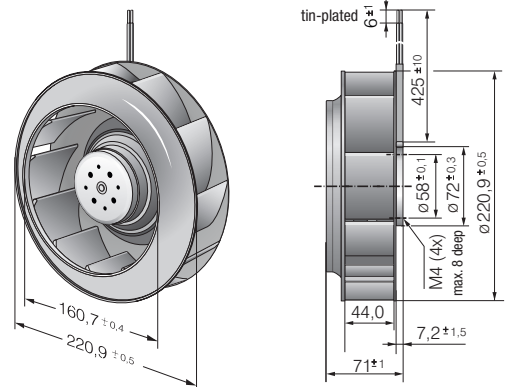
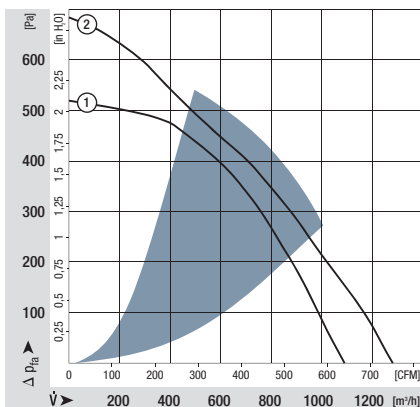



max. 1600 m<sup>3</sup>/h  
**S-Force**

# DC centrifugal fans

Series RER 225 TD Ø 225 x 99 mm



- **Material:** Impeller: GRP<sup>1)</sup>
- **Direction of air flow:** Axial: Intake  
Centrifugal: Exhaust
- **Direction of rotation:** Clockwise, seen on rotor
- **Connection:** Via single wires AWG 18, 20 or AWG 22, TR 64, speed signal and control input AWG 22
- **Highlights:** 3-phase fan drive with very smooth running and high efficiency  
Backwards-curved impeller
- **Mass:** 1030 g
- **Possible special versions:** (See chapter DC fans - specials)
  - Speed signal
  - Go / No-go alarm
  - Alarm with limit speed
  - External temperature sensor
  - Internal temperature sensor
  - PWM control input
  - Analogue control input
  - Multi-option control input
  - Protection against moisture
  - Protection against salt fog
  - Type of protection: IP 54

<sup>1)</sup> Fibreglass-reinforced plastic

Nominal data		Air flow	Air flow	Nominal voltage	Voltage range	Sound power level	Sintec sleeve bearings Ball bearings	Input power	Nominal speed	Temperature range	Service life L <sub>10</sub> (40 °C) ebm-papst Standard	Service life L <sub>10</sub> (T <sub>max</sub> ) ebm-papst Standard	Life expectancy L <sub>10</sub> (IPC (40 °C) see page 17	Curve
Type		m <sup>3</sup> /h	CFM	VDC	VDC	Bel(A)	■ / ■	Watts	rpm	°C	Hours	Hours	Hours	
NEW	RER 225-63/18/2 TDML0	1190	700	48	36...72	7,2	■	77	2 500	-20...+55	70 000 / 50 000	122 500	122 500	①
NEW	RER 225-63/18/2 TDM0	1340	789	48	36...72	7,8	■	108	2 800	-20...+55	55 000 / 40 000	92 500	92 500	②
NEW	RER 225-63/18/2 TDO	1600	941	48	36...72	8,1	■	163	3 300	-20...+55	52 500 / 37 500	87 500	87 500	③

Subject to alternations

Speed control range from 800 rpm at 7 % PWM up to nominal speed at > 90 % PWM. Standstill at 0 % PWM, standstill if control cable is interrupted.

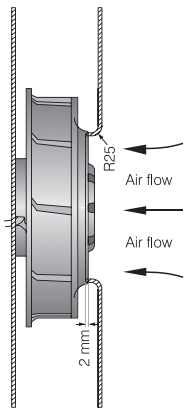

The air flow and noise level of the centrifugal fans without external housing depend on their individual installation conditions. The stated air flow and noise level were recorded under the following measurement parameters:  
Centrifugal fan mounted on a foundation plate 230 x 230 mm.  
Cover plate 230 x 230 mm, with an air inlet opening Ø 146 mm, arranged concentrically to the impeller.

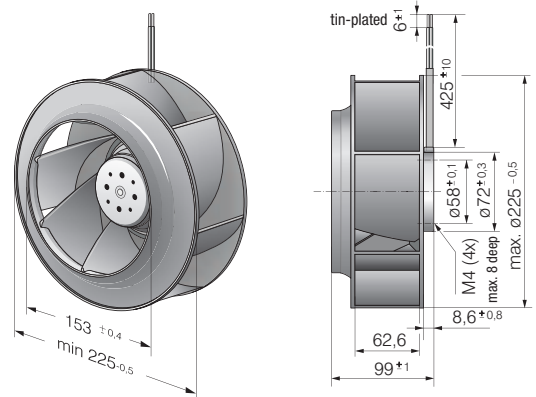
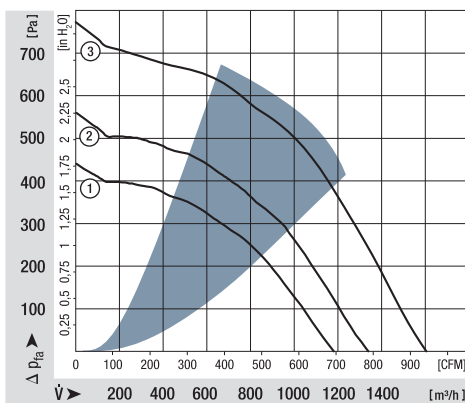

max. 1400 m<sup>3</sup>/h

# DC centrifugal fans – RadiCal

Ø 225 mm

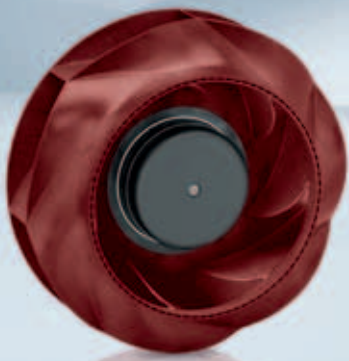

- **Material:** Impeller: Plastic PA  
Rotor: Coated in black
- **Number of blades:** 7
- **Direction of rotation:** Clockwise, seen on rotor
- **Type of protection:** IP 44, depending on installation and position
- **Insulation class:** "B"
- **Mounting position:** Any
- **Condensate discharges:** None
- **Operation mode:** Continuous operation (S1)
- **Bearings:** Maintenance-free ball bearings

Nominal data		Curve	Nominal voltage	Voltage range	Air flow	Speed / rpm	Input power	Current draw	Sound power level	Perm. amb. temp.	Technical features and electrical connections
Type	Motor	VDC	VDC	m <sup>3</sup> /h	rpm	W	A	dB(A)	°C		
R3G 225	M3G 074-CF	Ⓐ	24	16-28	1275	3240	200	8,30	75	-25...+60	p. 258 / J5)
R3G 225	M3G 074-CF	Ⓑ	48	36-57	1400	3500	245	5,00	73	-25...+60	p. 258 / J5)

Subject to alternations

Curve:

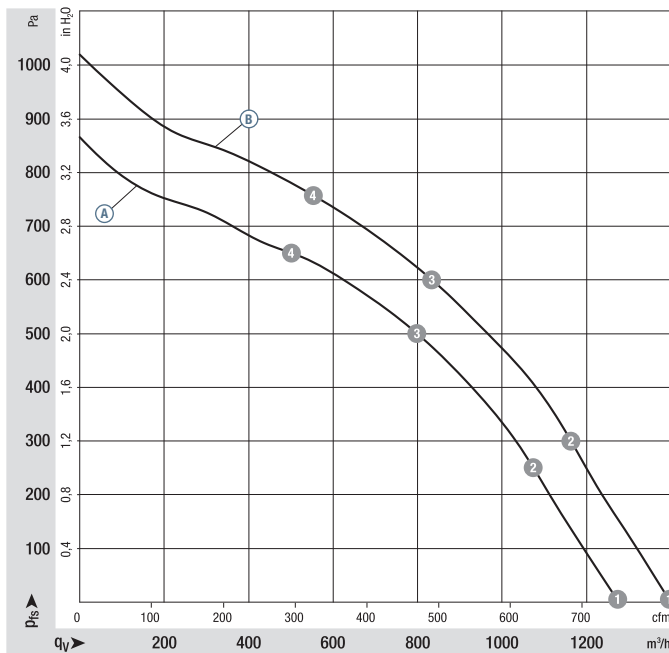

	n rpm	P <sub>ed</sub> W	I A	L <sub>WA</sub> dB(A)
Ⓐ ①	3240	200	8,30	81
Ⓐ ②	3200	208	8,66	78
Ⓐ ③	3185	213	8,88	74
Ⓐ ④	3260	194	8,02	77
Ⓑ ①	3500	245	5,00	83
Ⓑ ②	3440	257	5,35	80
Ⓑ ③	3435	260	5,43	76
Ⓑ ④	3500	239	4,97	78

Air performance measured as per: ISO 5801, Installation category A, with ebm-papst inlet nozzle without protection against accidental contact. Suction-side noise levels: LWA as per ISO 13347, LpA measured at 1 m distance to fan axis. The acoustic values given are only valid under the measurement conditions listed and may vary depending on the installation situation. With any deviation to the standard setup, the specific values have to be checked and reviewed once installed or fitted! For detailed information see <http://www.ebmpapst.com/general-conditions>

- **Technical features:** See electrical connections p. 258
- **Cable exit:** Variabel
- **Product conforming to standards:** EN 60950-1
- **Approvals:** GOST



Mass centrifugal fans



Centrifugal fans	kg	Inlet nozzle
R3G 225-RN28 -01	2,1	96358-2-4013
R3G 225-RN18 -02	2,1	96358-2-4013

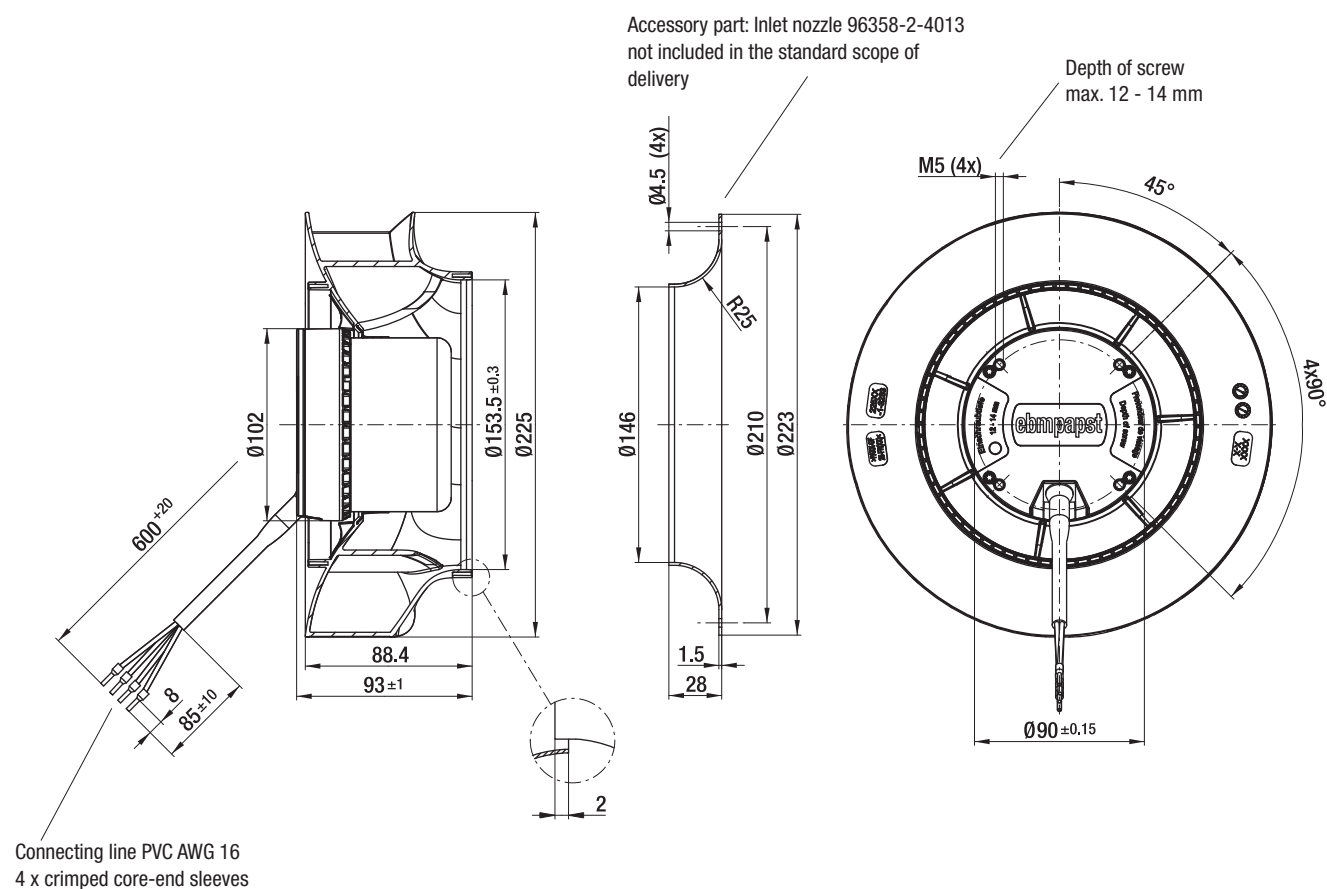

max. 1650 m<sup>3</sup>/h

# DC centrifugal fans – RadiCal

Ø 250 mm



- **Material:** Impeller: Plastic PA  
Rotor: Coated in black
- **Number of blades:** 7
- **Direction of rotation:** Clockwise, seen on rotor
- **Type of protection:** IP 44, depending on installation and position
- **Insulation class:** "B"
- **Mounting position:** Any
- **Condensate discharges:** None
- **Operation mode:** Continuous operation (S1)
- **Bearings:** Maintenance-free ball bearings

Nominal data		Curve	Nominal voltage	Voltage range	Air flow	Speed / rpm	Input power	Current draw	Sound power level	Perm. amb. temp.	Technical features and electrical connections
Type	Motor	VDC	VDC	m <sup>3</sup> /h	rpm	W	A	dB(A)	°C		
<b>R3G 250</b>	M3G 074-CF	Ⓐ	24	16-28	1650	3140	236	9,80	73	-25...+60	p. 258 / J5)
<b>R3G 250</b>	M3G 074-CF	Ⓑ	48	36-57	1640	3125	230	4,75	73	-25...+60	p. 258 / J5)

Subject to alternations

Curve:

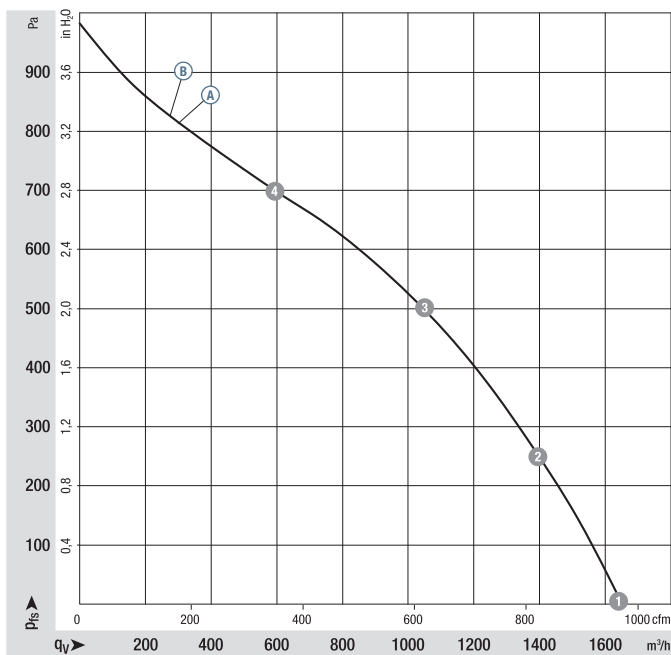

	n rpm	P <sub>ed</sub> W	I A	L <sub>WA</sub> dB(A)
Ⓐ 1	3140	236	9,80	81
Ⓐ 2	3075	260	10,80	77
Ⓐ 3	3035	276	11,45	75
Ⓐ 4	3095	256	10,66	75
Ⓑ 1	3125	230	4,75	81
Ⓑ 2	3065	249	5,20	77
Ⓑ 3	3025	266	5,55	75
Ⓑ 4	3090	244	5,09	78

Air performance measured as per: ISO 5801, Installation category A, with ebm-papst inlet nozzle without protection against accidental contact. Suction-side noise levels: LWA as per ISO 13347, LpA measured at 1 m distance to fan axis. The acoustic values given are only valid under the measurement conditions listed and may vary depending on the installation situation. With any deviation to the standard setup, the specific values have to be checked and reviewed once installed or fitted! For detailed information see <http://www.ebmpapst.com/general-conditions>

- **Technical features:** See electrical connections p. 258
- **Cable exit:** Variabel
- **Product conforming to standards:** EN 60950-1
- **Approvals:** GOST



Mass centrifugal fans



Centrifugal fans

kg

Inlet nozzle

R3G 250-RN46 -01

2,1

96359-2-4013

R3G 250-RN85 -02

2,1

96359-2-4013

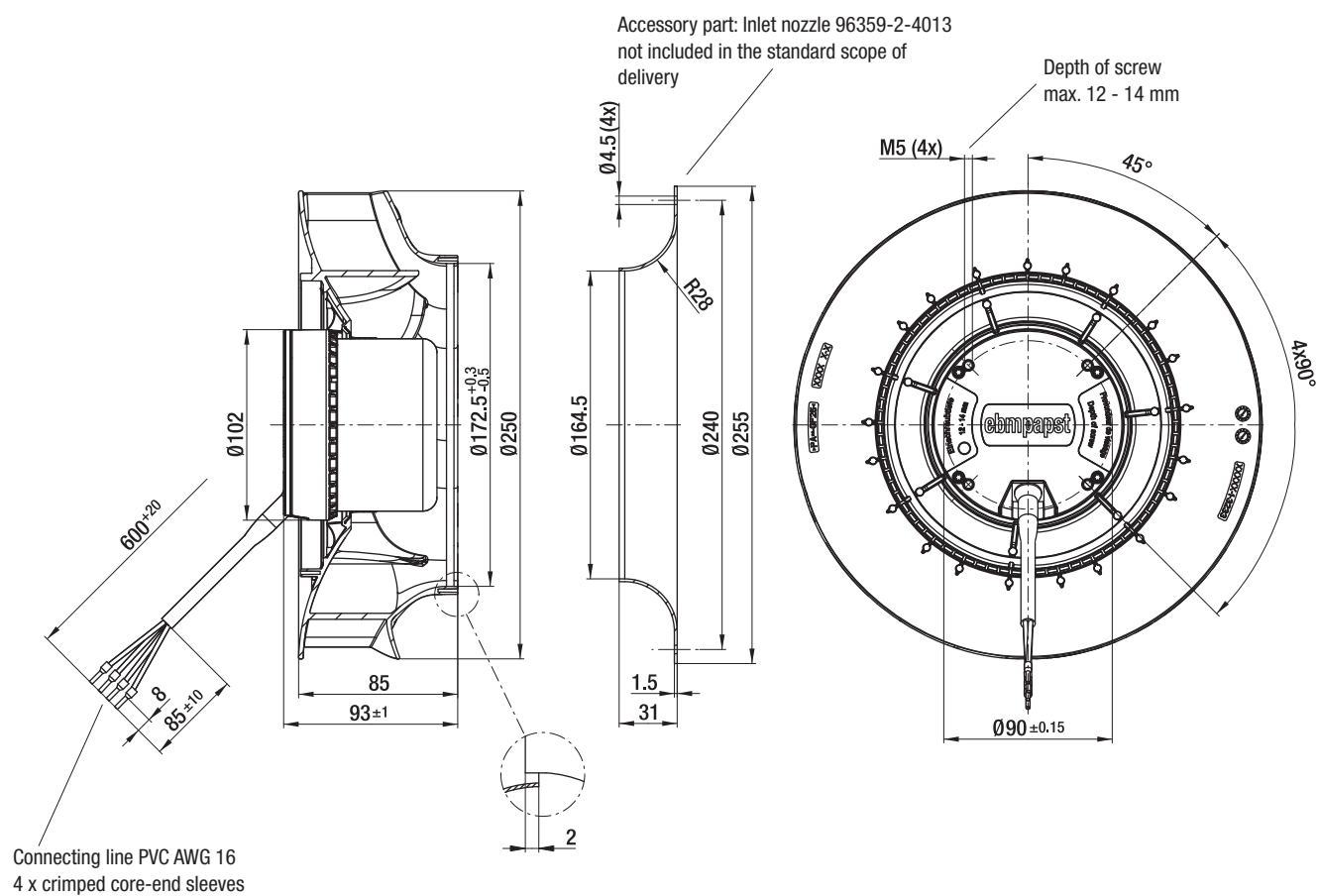

max. 2210 m<sup>3</sup>/h

# DC centrifugal fans – RadiCal

Ø 280 mm

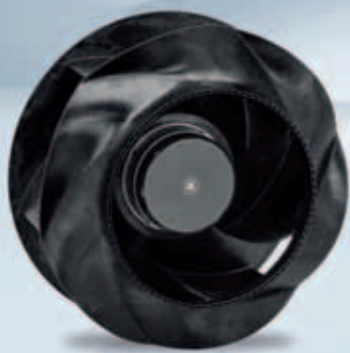

- **Material:** Impeller: Plastic PP  
Rotor: Coated in black
- **Number of blades:** 6
- **Direction of rotation:** Clockwise, seen on rotor
- **Type of protection:** IP 44, depending on installation and position
- **Insulation class:** "B"
- **Mounting position:** Any
- **Condensate discharges:** None
- **Operation mode:** Continuous operation (S1)
- **Bearings:** Maintenance-free ball bearings

Nominal data		Curve	Nominal voltage	Voltage range	Air flow	Speed / rpm	Input power	Current draw	Sound power level	Perm. amb. temp.	Technical features and electrical connections
Type	Motor	VDC	VDC	m <sup>3</sup> /h	rpm	W	A	dB(A)	°C		
<b>R3G 280</b>	M3G 074-CF	Ⓐ	24	16-28	2210	1930	148	6,10	67	-25...+60	p. 258 / J5)
<b>R3G 280</b>	M3G 074-CF	Ⓑ	48	36-57	2175	1910	140	2,90	67	-25...+60	p. 258 / J5)

Subject to alternations

Curve:

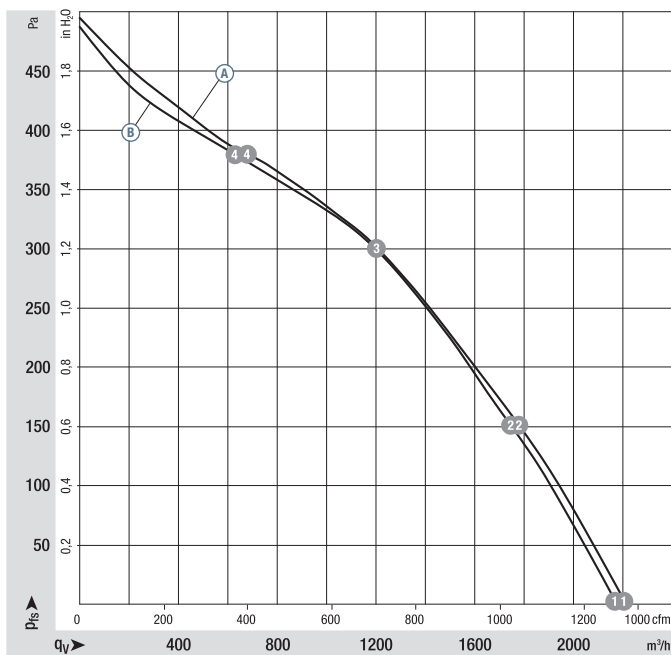

	n rpm	P <sub>ed</sub> W	I A	L <sub>WA</sub> dB(A)
Ⓐ 1	1930	148	6,10	74
Ⓐ 2	1870	162	6,76	67
Ⓐ 3	1840	173	7,21	64
Ⓐ 4	1905	153	6,36	68
Ⓑ 1	1910	140	2,90	74
Ⓑ 2	1845	158	3,30	67
Ⓑ 3	1830	163	3,40	64
Ⓑ 4	1900	141	2,93	68

Air performance measured as per: ISO 5801, Installation category A, with ebm-papst inlet nozzle without protection against accidental contact. Suction-side noise levels: LWA as per ISO 13347, LpA measured at 1 m distance to fan axis. The acoustic values given are only valid under the measurement conditions listed and may vary depending on the installation situation. With any deviation to the standard setup, the specific values have to be checked and reviewed once installed or fitted! For detailed information see <http://www.ebmpapst.com/general-conditions>



- **Technical features:** See electrical connections p. 258
- **Cable exit:** Variabel
- **Product conforming to standards:** EN 60950-1
- **Approvals:** GOST



Mass centrifugal fans



Centrifugal fans	kg	Inlet nozzle
R3G 280-RN30 -01	2,4	28000-2-4013
R3G 280-RNB1 -02	2,4	28000-2-4013

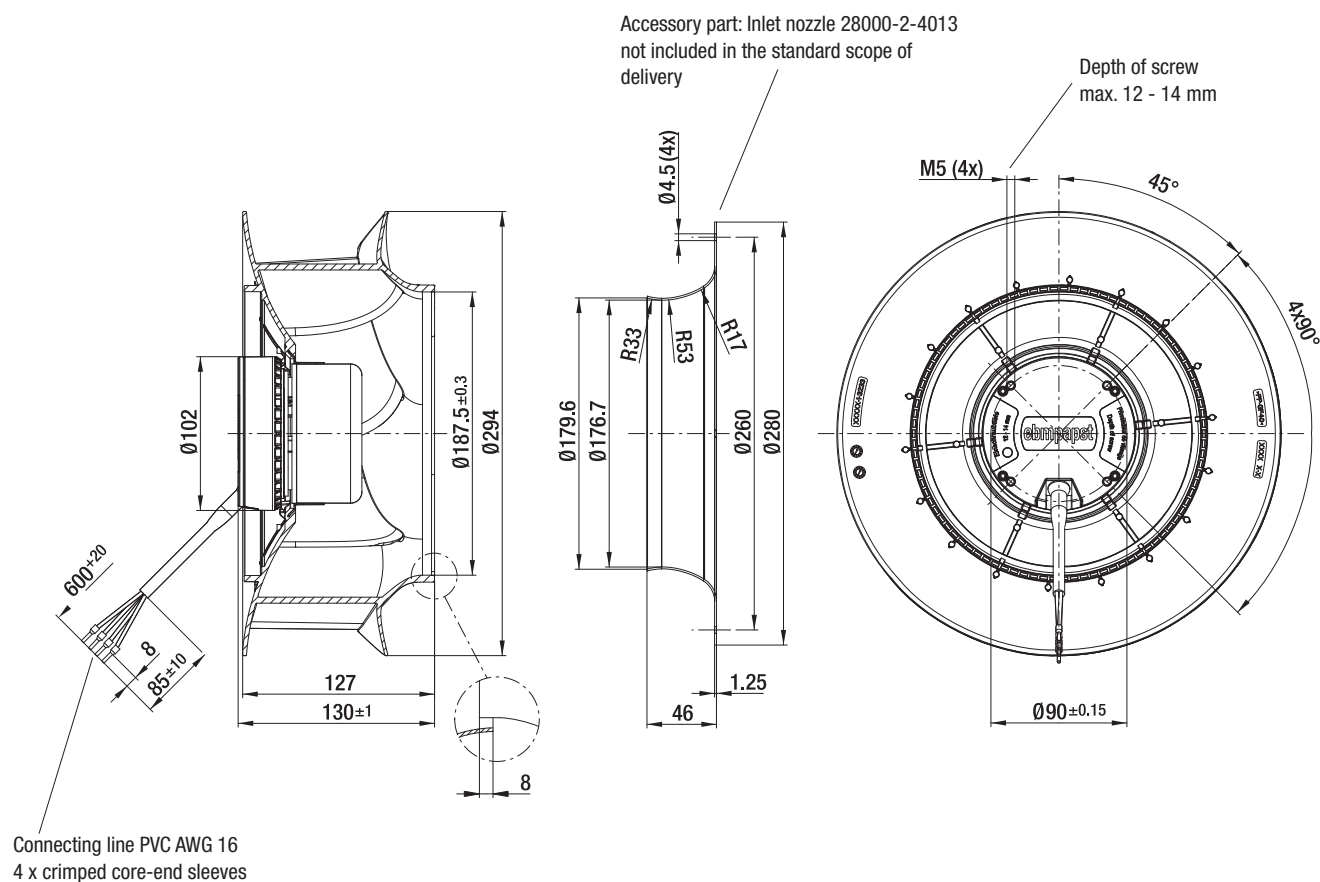

max. 2420 m<sup>3</sup>/h

# DC centrifugal fans – RadiCal

Ø 310 mm

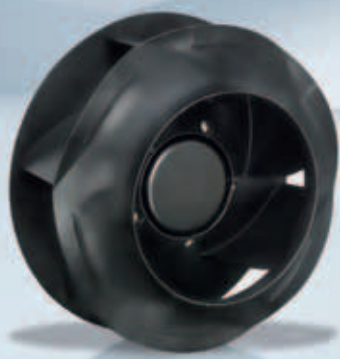

- **Material:** Impeller: Plastic PP  
Rotor: Coated in black
- **Number of blades:** 6
- **Direction of rotation:** Clockwise, seen on rotor
- **Type of protection:** IP 44, depending on installation and position
- **Insulation class:** "B"
- **Mounting position:** Any
- **Condensate discharges:** None
- **Operation mode:** Continuous operation (S1)
- **Bearings:** Maintenance-free ball bearings

Nominal data		Curve	Nominal voltage	Voltage range	Air flow	Speed / rpm	Input power	Current draw	Sound power level	Perm. amb. temp.	Technical features and electrical connections
Type	Motor	VDC	VDC	m <sup>3</sup> /h	RPM	W	A	dB(A)	°C		
<b>R3G 310</b>	M3G 074-CF	Ⓐ	24	16-28	2380	1625	122	5,00	64	-25...+60	p. 258 / J5)
<b>R3G 310</b>	M3G 074-CF	Ⓑ	48	36-57	2420	1650	123	2,60	64	-25...+60	p. 258 / J5)

Subject to alternations

Curve:

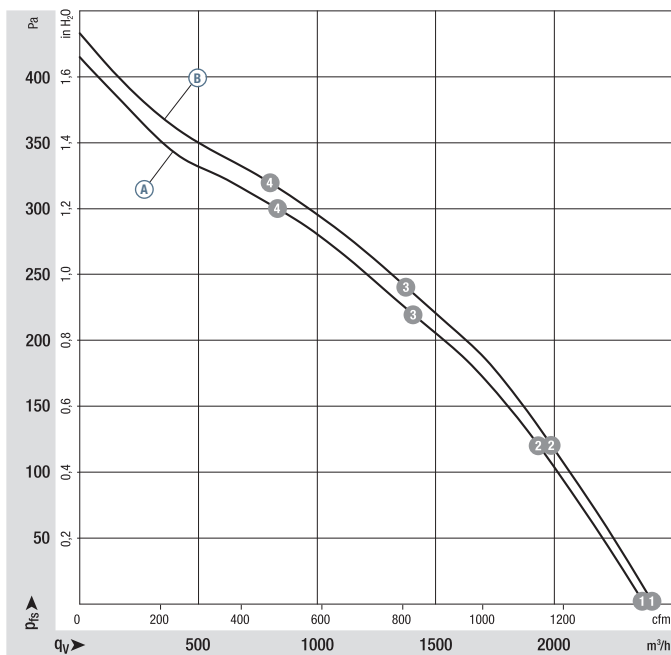

	n rpm	P <sub>ed</sub> W	I A	L <sub>WA</sub> dB(A)
Ⓐ 1	1625	122	5,00	70
Ⓐ 2	1540	145	6,03	67
Ⓐ 3	1520	152	6,34	63
Ⓐ 4	1550	143	5,95	65
Ⓑ 1	1650	123	2,60	70
Ⓑ 2	1570	147	3,07	66
Ⓑ 3	1545	156	3,26	63
Ⓑ 4	1580	144	3,01	66

Air performance measured as per: ISO 5801, Installation category A, with ebm-papst inlet nozzle without protection against accidental contact. Suction-side noise levels: LWA as per ISO 13347, LpA measured at 1 m distance to fan axis. The acoustic values given are only valid under the measurement conditions listed and may vary depending on the installation situation. With any deviation to the standard setup, the specific values have to be checked and reviewed once installed or fitted! For detailed information see <http://www.ebmpapst.com/general-conditions>

- **Technical features:** See electrical connections p. 258
- **Cable exit:** Variabel
- **Product conforming to standards:** EN 60950-1
- **Approvals:** GOST



Mass centrifugal fans



Centrifugal fans	kg	Inlet nozzle
R3G 310-RN99 -01	2,8	31000-2-4013
R3G 310-RN98 -02	2,8	31000-2-4013

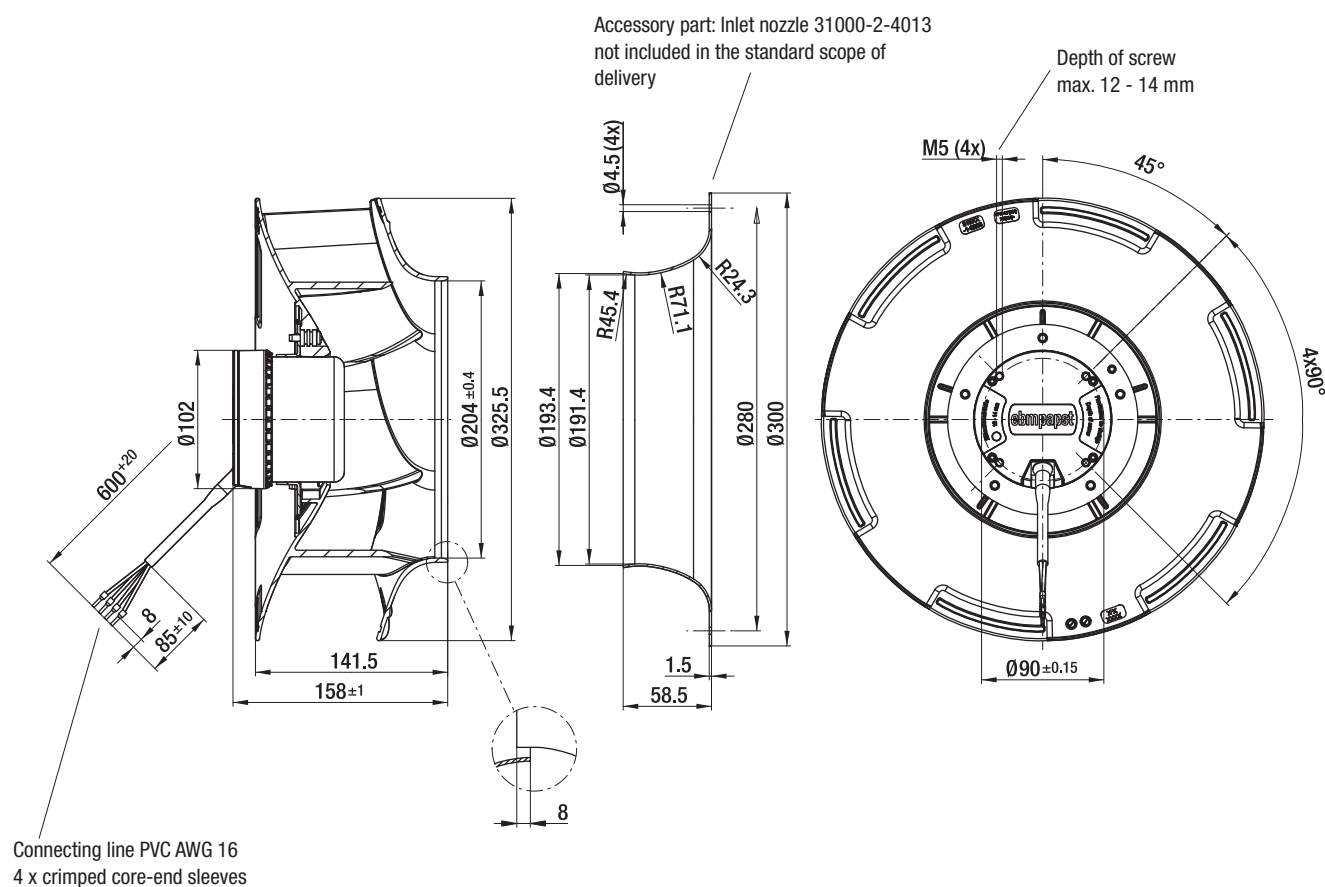

max. 155 m<sup>3</sup>/h

# DC-Querstromlüfter

Series QG 030 201...413 x 50 x 48 mm

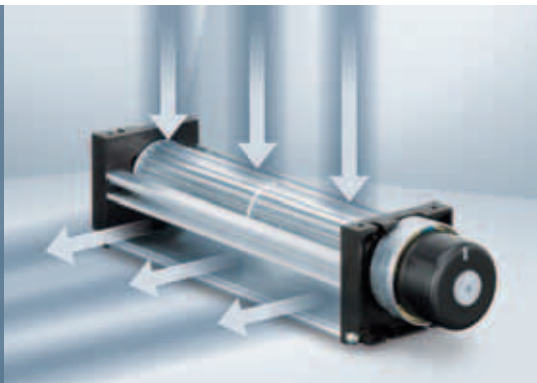

- **Material:** Housing: Aluminium  
Housing side parts: Plastic  
Impeller: Aluminium
- **Direction of air flow:** See photo
- **Connection:** Via single wires AWG 24, TR 64
- **Highlights:** Motor with ball bearing system  
Impeller retaining plate with plain bearing
- **Mass:** 235 / 290 / 380 / 415 g
- **Possible special versions:** (See chapter DC fans - specials)
  - Speed signal
  - Protection against moisture

Nominal data	Air flow		Nominal voltage	Voltage range	Sound power level	Sinter sleeve bearings Ball bearings	Input power	Nominal speed	Temperature range	Service life L <sub>10</sub> (40 °C) ebm-papst Standard	Service life L <sub>10</sub> (T <sub>max</sub> ) ebm-papst Standard	Life expectancy L <sub>10</sub> IPC (40 °C) see page 17	Curve
	m <sup>3</sup> /h	CFM											
QG 030-148/12	75	44	12	8...14	49	5,7	■/■	6,2	-20...+60	30 000 / 20 000	50 000	50 000	①
QG 030-198/12	100	59	12	8...14	51	5,8	■/■	8,0	-20...+60	30 000 / 20 000	50 000	50 000	②
QG 030-303/12	140	82	12	8...14	51	5,8	■/■	8,7	-20...+60	30 000 / 20 000	50 000	50 000	③
QG 030-353/12	155	91	12	8...14	51	5,9	■/■	9,6	-20...+60	30 000 / 20 000	50 000	50 000	④
QG 030-148/14	75	44	24	16...28	49	5,7	■/■	6,2	-20...+60	30 000 / 20 000	50 000	50 000	①
QG 030-198/14	100	59	24	16...28	51	5,8	■/■	8,0	-20...+60	30 000 / 20 000	50 000	50 000	②
QG 030-303/14	140	82	24	16...28	51	5,8	■/■	8,7	-20...+60	30 000 / 20 000	50 000	50 000	③
QG 030-353/14	155	91	24	16...28	51	5,9	■/■	9,6	-20...+60	30 000 / 20 000	50 000	50 000	④

Subject to alternations

The values for service life were recorded with the fan installed horizontally.

Type	Dimension:	L	L <sub>1</sub>	Mass
QG 030-148/ ..		203,4 <sup>+1,5</sup>	148	235 g
QG 030-198/ ..		260,4 <sup>+1,5</sup>	198	290 g
QG 030-303/ ..		365,4 <sup>+1,5</sup>	303	380 g
QG 030-353/ ..		415,4 <sup>+1,5</sup>	353	415 g

----- Tangential fans are only suitable for operation with high rate and low back pressure.

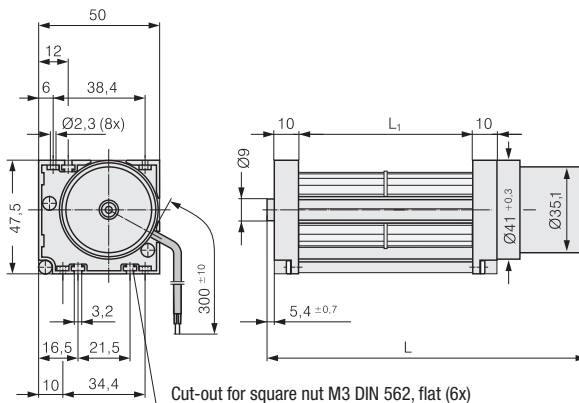
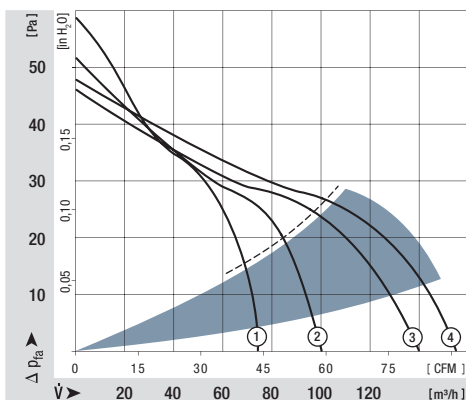

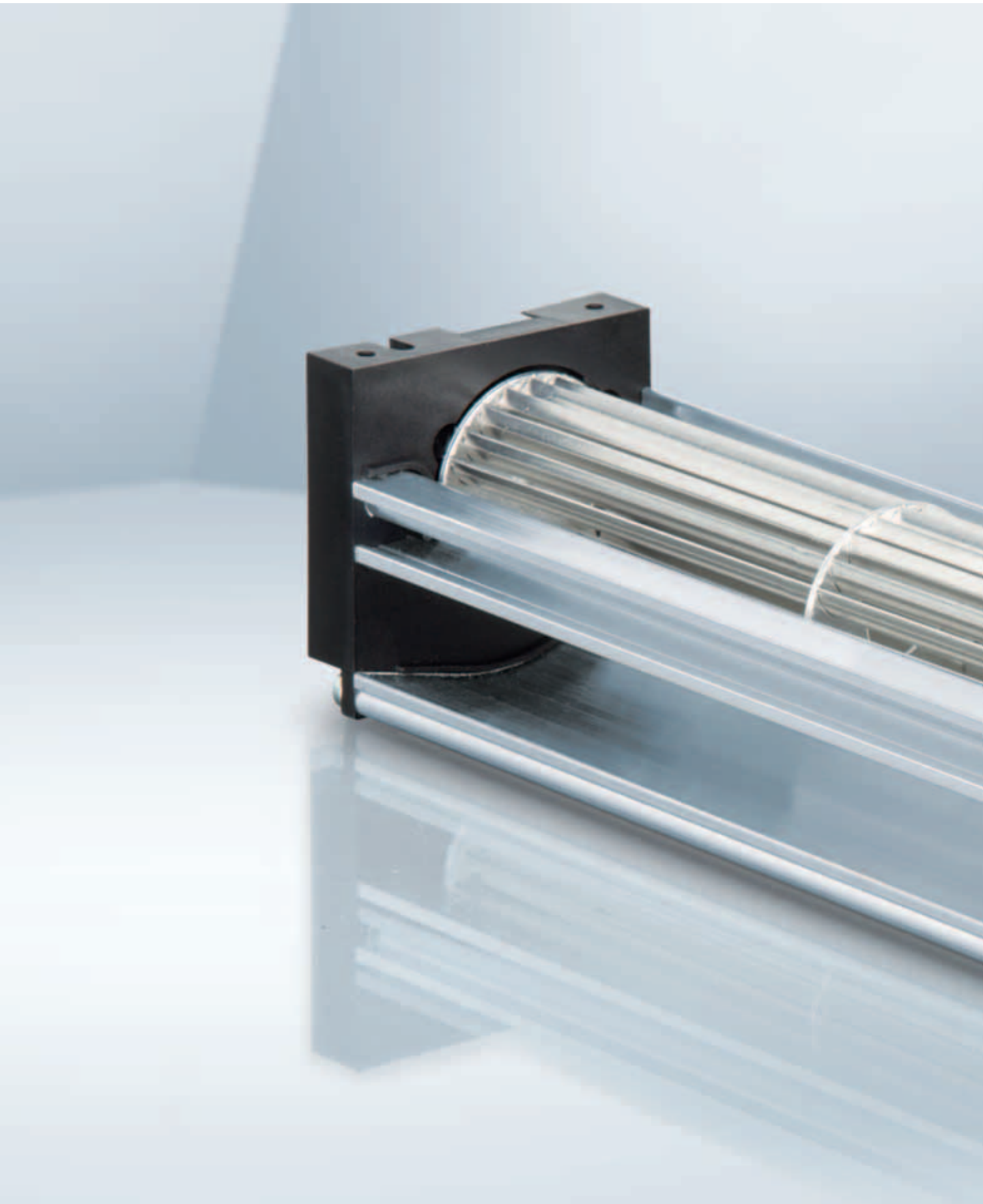

max. 95 m<sup>3</sup>/h

# DC centrifugal fans and blowers

Ø 85 mm



- **Material:** Housing: Die-cast aluminium  
Impeller: Hot-dip galvanised sheet steel  
Rotor: Galvanised
- **Direction of rotation:** Clockwise, seen on rotor
- **Type of protection:** IP 22
- **Insulation class:** "B"
- **Mounting position:** Any
- **Condensate discharges:** None
- **Operation mode:** Continuous operation (S1)
- **Bearings:** Maintenance-free ball bearings

Nominal data		Curve	Nominal voltage	Voltage range	Air flow	Speed / rpm	Input power	Current draw	Sound power level	Min. back-pressure	Perm. amb. temp.	Technical features and electrical connections
Type	Motor	VDC	VDC	m <sup>3</sup> /h	rpm	W	A	dB(A)	Pa	°C		
*1G 085	M1G 045-BE	Ⓐ	24	16-28	95	2850	14	0,64	57	0	-25...+60	p. 255 / G)
*1G 085	M1G 045-BE	Ⓐ	48	36-57	95	2850	14	0,32	57	0	-25...+60	p. 255 / G)

Subject to alternations

### Curve:

U<sub>N</sub> = nominal voltage  
(24 V / 48 V)

U<sub>R</sub> = overvoltage  
(28 V / 57 V)

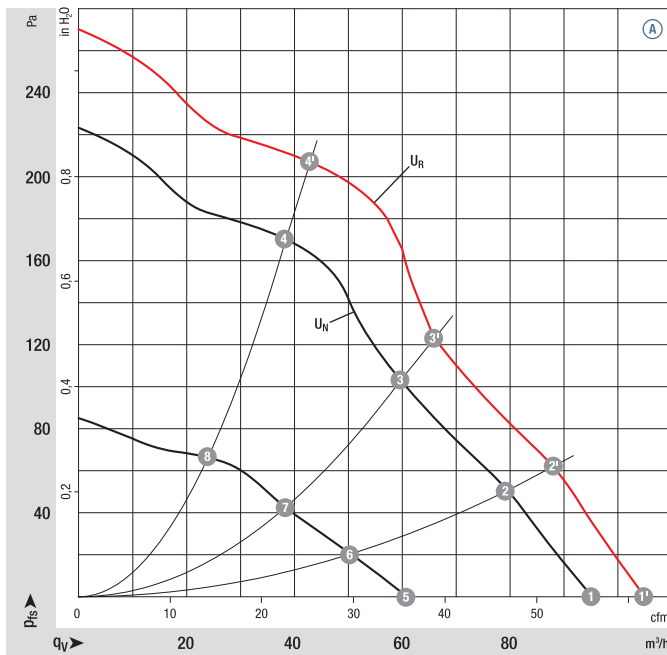

	n rpm	P <sub>ed</sub> W	Lp <sub>A</sub> dB(A)	η <sub>IL</sub> %
Ⓐ 1'	3180	19	59	—
Ⓐ 2'	3300	16	57	28
Ⓐ 3'	3500	15	57	32
Ⓐ 4'	3800	12	57	37
Ⓐ 1	2850	14	57	—
Ⓐ 2	3000	12	55	28
Ⓐ 3	3180	11	55	32
Ⓐ 4	3400	9	54	37
Ⓐ 5	1890	5	46	—
Ⓐ 6	1970	4	44	25
Ⓐ 7	2070	4	44	30
Ⓐ 8	2170	3	42	33

Air performance measured as per: ISO 5801, Installation category A, with ebm-papst inlet nozzle without protection against accidental contact. Suction-side noise levels: LWA as per ISO 13347, LpA measured at 1 m distance to fan axis. The acoustic values given are only valid under the measurement conditions listed and may vary depending on the installation situation. With any deviation to the standard setup, the specific values have to be checked and reviewed once installed or fitted! For detailed information see <http://www.ebmpapst.com/general-conditions>



- **Technical features:** See electrical connections p. 255
- **Cable exit:** Axial
- **Protection class:** I
- **Product conforming to standards:** EN 60950-1
- **Approvals:** Ⓐ (48 VDC) CCC



Mass centrifugal fans

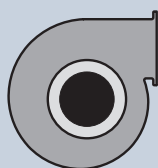

Mass centrifugal blowers

Centrifugal fans	kg	Centrifugal blowers with flange	kg
R1G 085-AB05 -01	0,5	G1G 085-AB05 -01	0,8
R1G 085-AB07 -01	0,5	G1G 085-AB07 -01	0,8

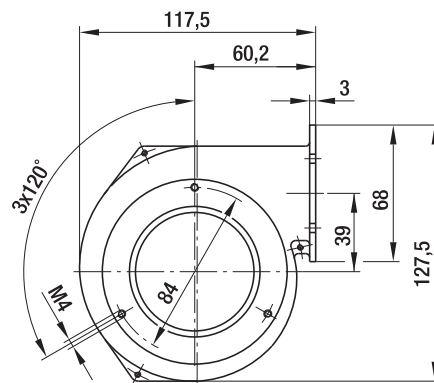
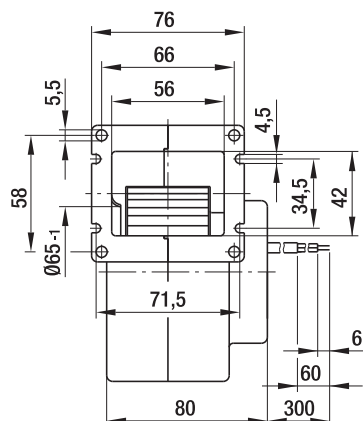
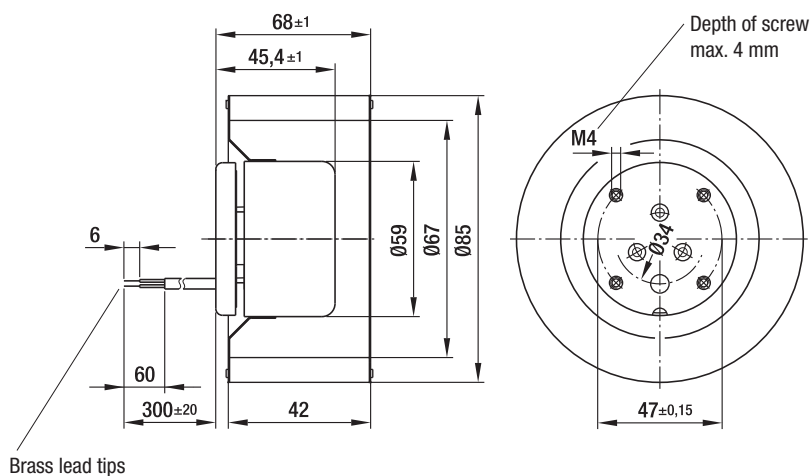

max. 95 m<sup>3</sup>/h

# DC centrifugal fans and blowers

Ø 97 mm

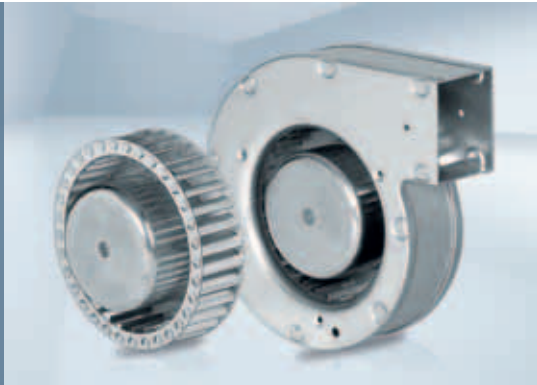

- **Material:** Housing: Hot-dip galvanised sheet steel  
Impeller: Hot-dip galvanised sheet steel  
Rotor: Galvanised
- **Direction of rotation:** Clockwise, seen on rotor
- **Type of protection:** IP 22
- **Insulation class:** "B"
- **Mounting position:** Any
- **Condensate discharges:** None
- **Operation mode:** Continuous operation (S1)
- **Bearings:** Maintenance-free ball bearings

Nominal data		Curve	Nominal voltage	Voltage range	Air flow	Speed / rpm	Input power	Current draw	Sound power level	Min. back-pressure	Perm. amb. temp.	Technical features and electrical connections
Type	Motor	VDC	VDC	m <sup>3</sup> /h	rpm	W	A	dB(A)	Pa	°C		
*1G 097	M1G 045-BE	Ⓐ	24	16-28	95	2650	16	0,75	59	0	-25...+60	p. 255 / G)
*1G 097	M1G 045-BE	Ⓐ	48	36-57	95	2650	16	0,38	59	0	-25...+60	p. 255 / G)

Subject to alternations

**Curve:**

U<sub>N</sub> = nominal voltage  
(24 V / 48 V)

U<sub>R</sub> = overvoltage  
(28 V / 57 V)

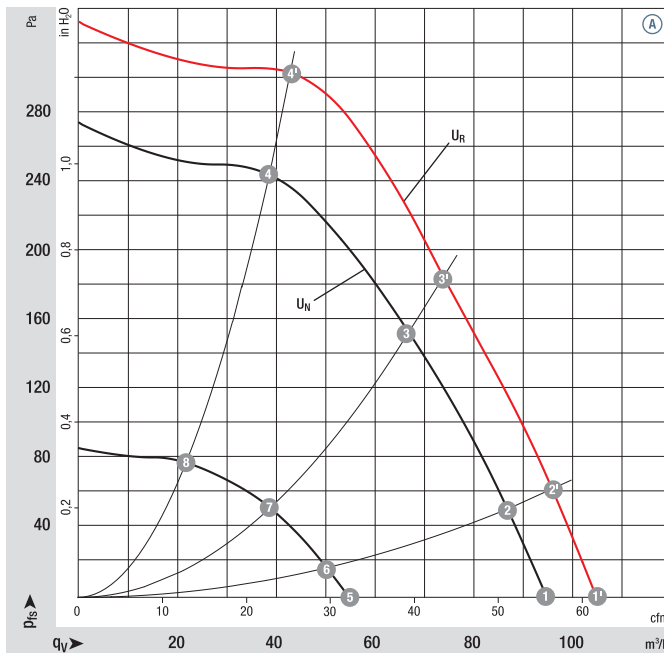

	n rpm	P <sub>ed</sub> W	Lp <sub>A</sub> dB(A)	η <sub>IL</sub> %
Ⓐ 1'	2920	22	62	—
Ⓐ 2'	3030	21	61	41
Ⓐ 3'	3300	17	59	48
Ⓐ 4'	3700	13	58	48
Ⓐ 1	2650	16	59	—
Ⓐ 2	2730	15	58	41
Ⓐ 3	2960	13	56	48
Ⓐ 4	3290	10	55	48
Ⓐ 5	1615	4	45	—
Ⓐ 6	1650	4	45	38
Ⓐ 7	1745	4	43	46
Ⓐ 8	1880	3	42	47

Air performance measured as per: ISO 5801, Installation category A, with ebm-papst inlet nozzle without protection against accidental contact. Suction-side noise levels: LWA as per ISO 13347, LpA measured at 1 m distance to fan axis. The acoustic values given are only valid under the measurement conditions listed and may vary depending on the installation situation. With any deviation to the standard setup, the specific values have to be checked and reviewed once installed or fitted! For detailed information see <http://www.ebmpapst.com/general-conditions>

- **Technical features:** See electrical connections p. 255
- **Cable exit:** Axial
- **Protection class:** I
- **Product conforming to standards:** EN 60950-1
- **Approvals:** Ⓐ (48 VDC) CCC



Mass centrifugal fans



Mass centrifugal blowers

Centrifugal fans	kg	Centrifugal blowers with flange	kg
R1G 097-AA05 -01	0,5	G1G 097-AA05 -01	0,8
R1G 097-AA07 -01	0,5	G1G 097-AA07 -01	0,8

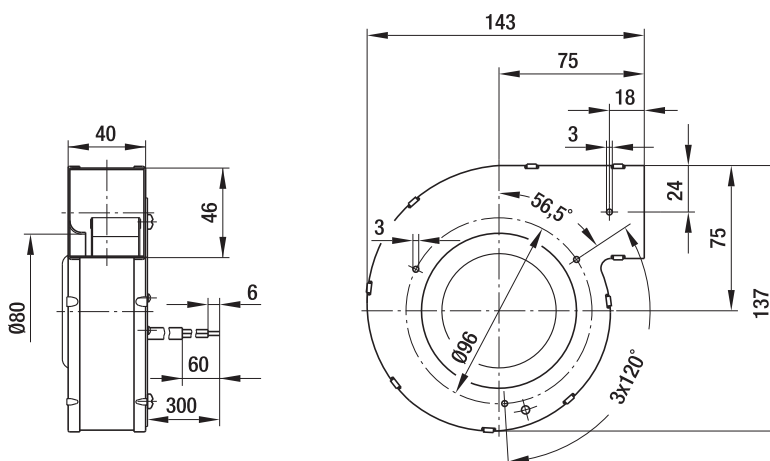
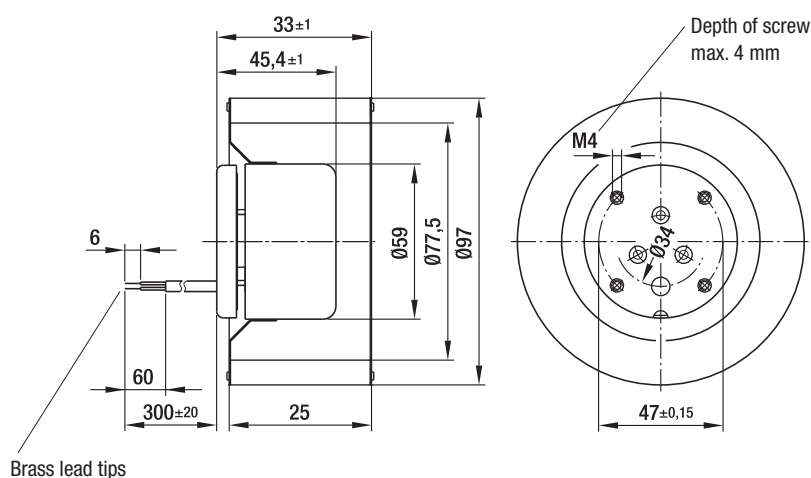

max. 200 m<sup>3</sup>/h

# DC centrifugal fans and blowers

Ø 108 mm



- **Material:** Housing: Die-cast aluminium  
Impeller: Hot-dip galvanised sheet steel  
Rotor: Galvanised
- **Direction of rotation:** Clockwise, seen on rotor
- **Type of protection:** IP 22
- **Insulation class:** "B"
- **Mounting position:** Any
- **Condensate discharges:** None
- **Operation mode:** Continuous operation (S1)
- **Bearings:** Maintenance-free ball bearings

Nominal data		Curve	Nominal voltage	Voltage range	Air flow	Speed / rpm	Input power	Current draw	Sound power level	Min. back-pressure	Perm. amb. temp.	Technical features and electrical connections
Type	Motor	VDC	VDC	m <sup>3</sup> /h	rpm	W	A	dB(A)	Pa	°C		
*1G 108	M1G 055-BD	Ⓐ	24	16-28	200	3000	42	2,00	65	0	-25...+60	p. 255 / G)
*1G 108	M1G 055-BD	Ⓐ	48	36-57	200	3000	42	1,00	65	0	-25...+60	p. 255 / G)

Subject to alternations

### Curve:

U<sub>N</sub> = nominal voltage  
(24 V / 48 V)

U<sub>R</sub> = overvoltage  
(28 V / 57 V)

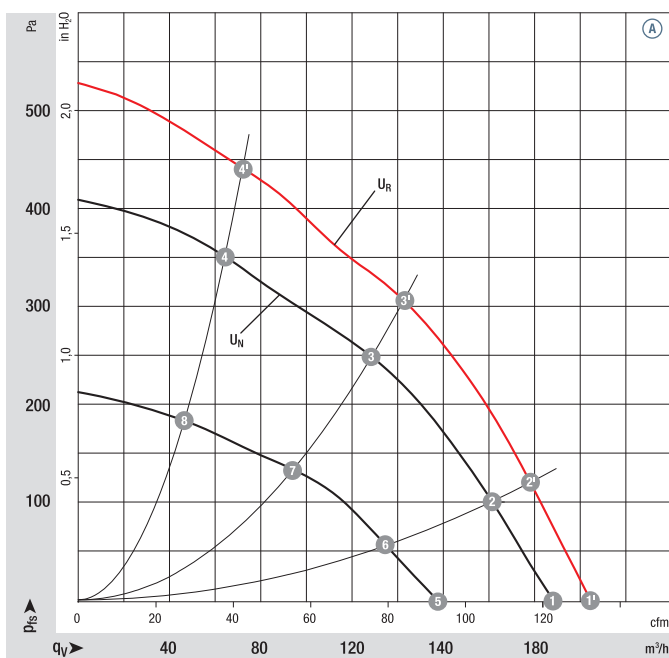

	n rpm	P <sub>ed</sub> W	Lp <sub>A</sub> dB(A)	η <sub>IL</sub> %
Ⓐ 1'	3230	55	67	—
Ⓐ 2'	3410	52	66	33
Ⓐ 3'	3800	43	65	41
Ⓐ 4'	4100	35	64	33
Ⓐ 1	3000	42	65	—
Ⓐ 2	3140	40	64	33
Ⓐ 3	3420	32	63	41
Ⓐ 4	3690	26	63	33
Ⓐ 5	2300	20	61	—
Ⓐ 6	2380	17	58	33
Ⓐ 7	2550	14	55	41
Ⓐ 8	2720	11	55	33

Air performance measured as per: ISO 5801, Installation category A, with ebm-papst inlet nozzle without protection against accidental contact. Suction-side noise levels: LWA as per ISO 13347, LpA measured at 1 m distance to fan axis. The acoustic values given are only valid under the measurement conditions listed and may vary depending on the installation situation. With any deviation to the standard setup, the specific values have to be checked and reviewed once installed or fitted! For detailed information see <http://www.ebmpapst.com/general-conditions>

- **Technical features:** See electrical connections p. 255
- **EMC:** Interference emission acc. to EN 61000-6-3  
Interference immunity acc. to EN 61000-6-2
- **Cable exit:** Axial
- **Protection class:** I
- **Product conforming to standards:** EN 60950-1
- **Approvals:** Ⓐ (24 VDC) UL, CSA, Ⓐ (48 VDC) CCC



Mass centrifugal fans

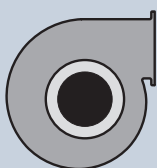

Mass centrifugal blowers

Centrifugal fans	kg	Centrifugal blowers with flange	kg
R1G 108-AB17 -02	0,7	G1G 108-AB17 -02	1,4
R1G 108-AB41 -02	0,7	G1G 108-AB41 -02	1,4

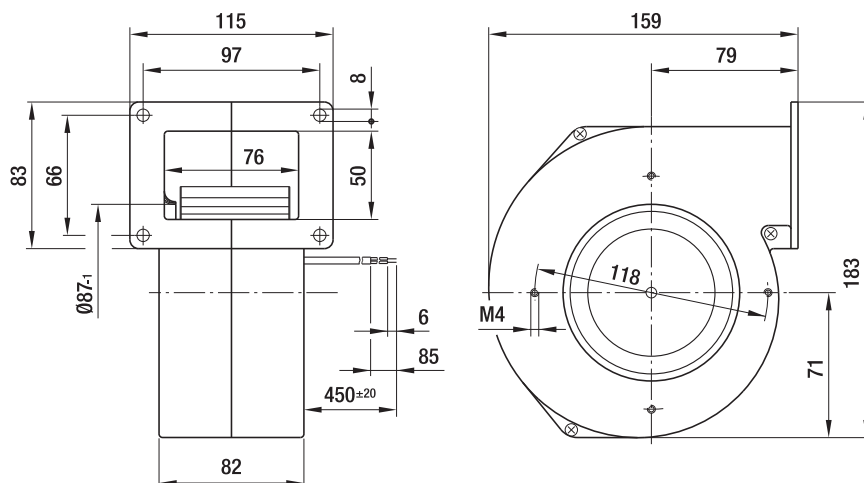
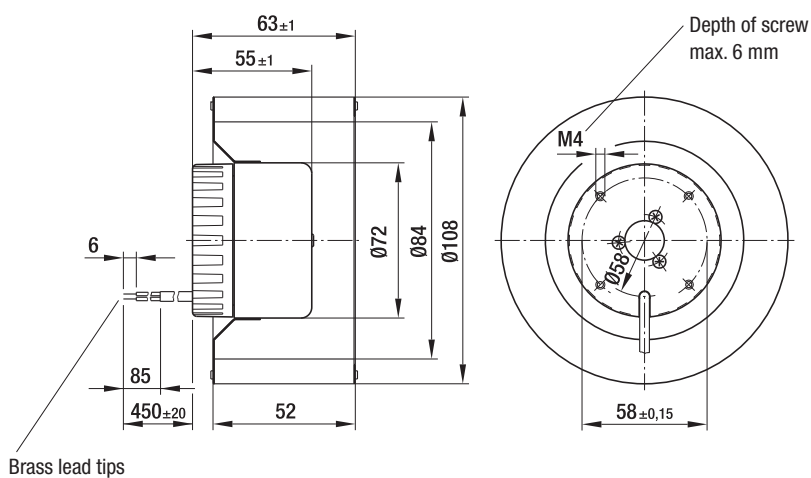

max. 255 m<sup>3</sup>/h

# DC centrifugal fans and blowers

Ø 120 mm



- **Material:** Housing: Die-cast aluminium  
Impeller: Hot-dip galvanised sheet steel  
Rotor: Galvanised
- **Direction of rotation:** Clockwise, seen on rotor
- **Type of protection:** IP 22
- **Insulation class:** "B"
- **Mounting position:** Any
- **Condensate discharges:** None
- **Operation mode:** Continuous operation (S1)
- **Bearings:** Maintenance-free ball bearings

Nominal data		Curve	Nominal voltage	Voltage range	Air flow	Speed / rpm	Input power	Current draw	Sound power level	Min. back-pressure	Perm. amb. temp.	Technical features and electrical connections
Type	Motor	VDC	VDC	m <sup>3</sup> /h	rpm	W	A	dB(A)	Pa	°C		
*1G 120	M1G 055-BD	Ⓐ	24	16-28	255	2200	40	1,90	62	0	-25...+60	p. 255 / G)
*1G 120	M1G 055-BD	Ⓐ	48	36-57	255	2200	40	0,95	62	0	-25...+60	p. 255 / G)

Subject to alternations

### Curve:

U<sub>N</sub> = nominal voltage  
(24 V / 48 V)

U<sub>R</sub> = overvoltage  
(28 V / 57 V)

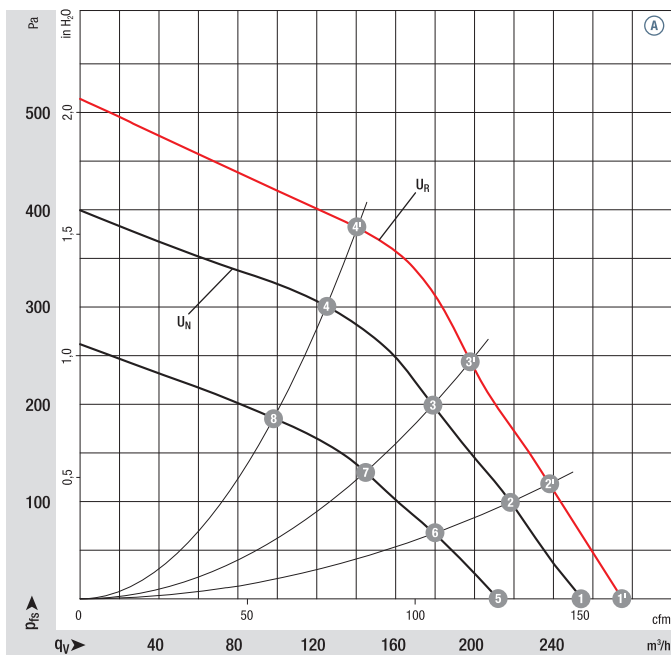

	n rpm	P <sub>ed</sub> W	L <sub>pA</sub> dB(A)	η <sub>IL</sub> %
Ⓐ 1'	2410	50	63	—
Ⓐ 2'	2620	47	62	58
Ⓐ 3'	2870	44	61	60
Ⓐ 4'	3200	36	62	55
Ⓐ 1	2200	40	62	—
Ⓐ 2	2410	36	60	59
Ⓐ 3	2600	32	58	62
Ⓐ 4	2880	25	58	55
Ⓐ 5	1870	24	55	—
Ⓐ 6	1990	21	54	58
Ⓐ 7	2100	18	53	61
Ⓐ 8	2310	14	54	54

Air performance measured as per: ISO 5801, Installation category A, with ebm-papst inlet nozzle without protection against accidental contact. Suction-side noise levels: LWA as per ISO 13347, LpA measured at 1 m distance to fan axis. The acoustic values given are only valid under the measurement conditions listed and may vary depending on the installation situation. With any deviation to the standard setup, the specific values have to be checked and reviewed once installed or fitted! For detailed information see <http://www.ebmpapst.com/general-conditions>



- **Technical features:** See electrical connections p. 255
- **EMC:** Interference emission acc. to EN 61000-6-3  
Interference immunity acc. to EN 61000-6-2
- **Cable exit:** Axial
- **Protection class:** I
- **Product conforming to standards:** EN 60950-1
- **Approvals:** Ⓐ (24 VDC) UL, CSA, Ⓐ (48 VDC) CCC



Mass centrifugal fans

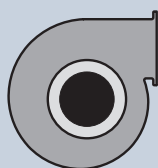

Mass centrifugal blowers

Centrifugal fans	kg	Centrifugal blowers with flange	kg
R1G 120-AB67 -02	0,8	G1G 120-AB67 -02	1,6
R1G 120-AB71 -02	0,8	G1G 120-AB71 -02	1,6

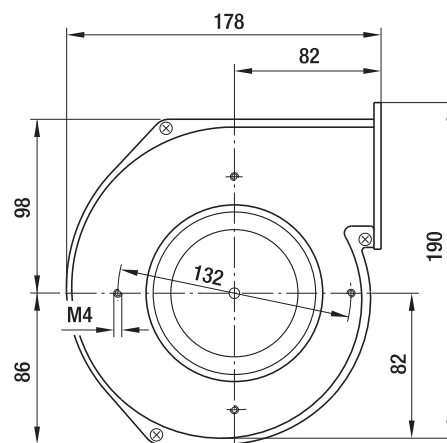
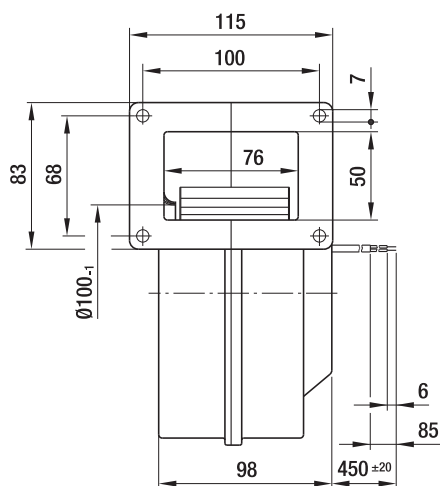
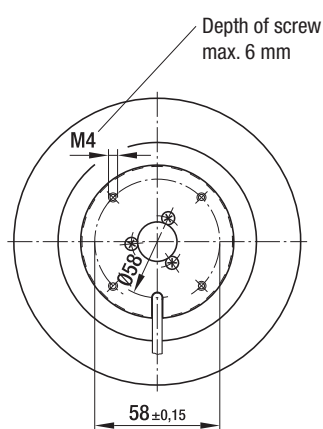
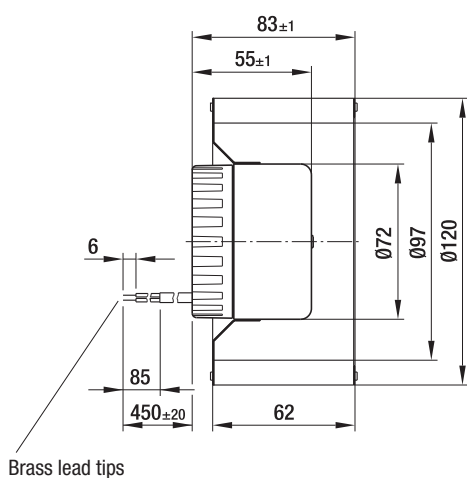

max. 225 m<sup>3</sup>/h

# DC centrifugal fans and blowers

Ø 133 mm



- **Material:** Housing: Die-cast aluminium  
Impeller: Hot-dip galvanised sheet steel  
Rotor: Galvanised
- **Direction of rotation:** Clockwise, seen on rotor
- **Type of protection:** IP 22
- **Insulation class:** "B"
- **Mounting position:** Any
- **Condensate discharges:** None
- **Operation mode:** Continuous operation (S1)
- **Bearings:** Maintenance-free ball bearings

Nominal data		Curve	Nominal voltage	Voltage range	Air flow	Speed / rpm	Input power	Current draw	Sound power level	Min. back-pressure	Perm. amb. temp.	Technical features and electrical connections
Type	Motor	VDC	VDC	m <sup>3</sup> /h	rpm	W	A	dB(A)	Pa	°C		
*1G 133	M1G 055-BD	Ⓐ	24	16-28	225	2000	40	2,20	64	0	-25...+60	p. 255 / G)
*1G 133	M1G 055-BD	Ⓐ	48	36-57	225	2000	40	1,10	64	0	-25...+60	p. 255 / G)

Subject to alternations

**Curve:**

U<sub>N</sub> = nominal voltage  
(24 V / 48 V)

U<sub>R</sub> = overvoltage  
(28 V / 57 V)

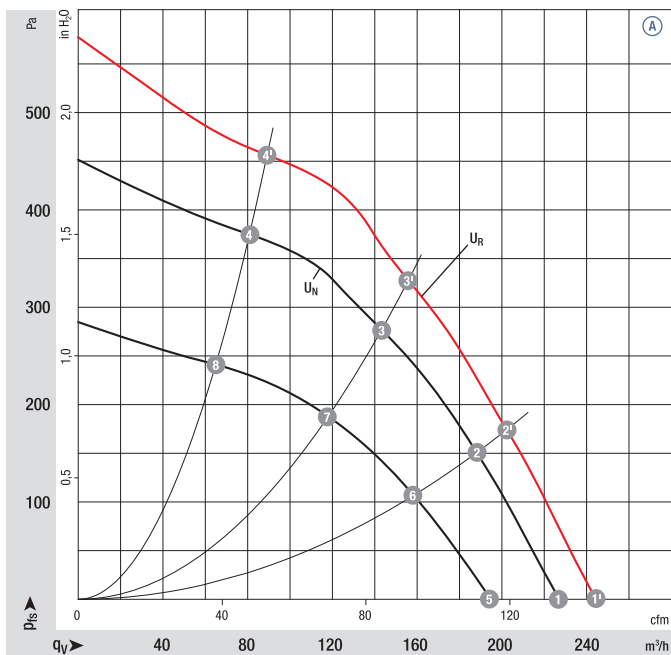

	n rpm	P <sub>ed</sub> W	Lp <sub>A</sub> dB(A)	η <sub>IL</sub> %
Ⓐ 1'	2170	57	66	—
Ⓐ 2'	2410	51	66	47
Ⓐ 3'	2750	44	64	49
Ⓐ 4'	3200	36	66	32
Ⓐ 1	2000	45	64	—
Ⓐ 2	2230	40	64	49
Ⓐ 3	2540	35	62	51
Ⓐ 4	2920	27	63	33
Ⓐ 5	1750	28	60	—
Ⓐ 6	1910	24	59	50
Ⓐ 7	2120	20	58	53
Ⓐ 8	2370	15	59	35

Air performance measured as per: ISO 5801, Installation category A, with ebm-papst inlet nozzle without protection against accidental contact. Suction-side noise levels: LWA as per ISO 13347, LpA measured at 1 m distance to fan axis. The acoustic values given are only valid under the measurement conditions listed and may vary depending on the installation situation. With any deviation to the standard setup, the specific values have to be checked and reviewed once installed or fitted! For detailed information see [http://www.ebmpapst.com/general\\_conditions](http://www.ebmpapst.com/general_conditions)

- **Technical features:** See electrical connections p. 255
- **EMC:** Interference emission acc. to EN 61000-6-3  
Interference immunity acc. to EN 61000-6-2
- **Cable exit:** Lateral
- **Protection class:** I
- **Product conforming to standards:** EN 60950-1
- **Approvals:** Ⓐ (24 VDC) UL, CSA, Ⓐ (48 VDC) CCC



Mass centrifugal fans



Mass centrifugal blowers

Centrifugal fans	kg	Centrifugal blowers with flange	kg
R1G 133-AE19 -02	0,7	G1G 133-DE19 -02	1,3
R1G 133-AE03 -02	0,7	G1G 133-DE03 -02	1,3

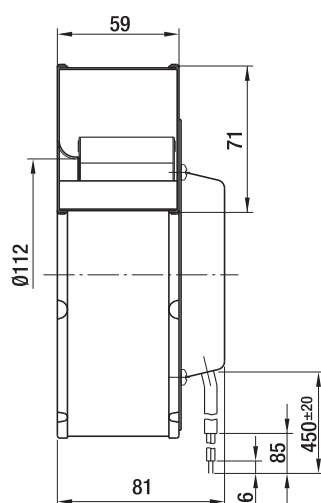
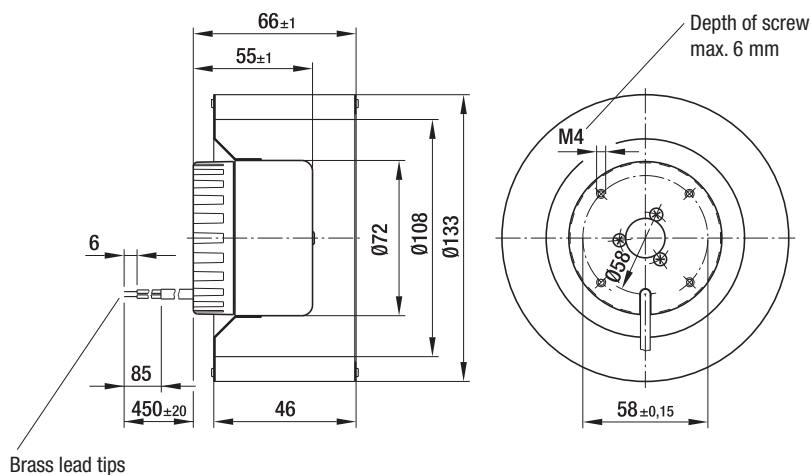

max. 410 m<sup>3</sup>/h

# DC centrifugal fans and blowers

Ø 140 mm



- **Material:** Housing: Die-cast aluminium  
Impeller: Hot-dip galvanised sheet steel  
Rotor: Galvanised
- **Direction of rotation:** Clockwise, seen on rotor
- **Type of protection:** IP 22
- **Insulation class:** "B"
- **Mounting position:** Any
- **Condensate discharges:** None
- **Operation mode:** Continuous operation (S1)
- **Bearings:** Maintenance-free ball bearings

Nominal data		Curve	Nominal voltage	Voltage range	Air flow	Speed / rpm	Input power	Current draw	Sound power level	Min. back-pressure	Perm. amb. temp.	Technical features and electrical connections
Type	Motor	VDC	VDC	m <sup>3</sup> /h	rpm	W	A	dB(A)	Pa	°C		
*1G 140	M1G 055-BD	Ⓐ	24	16-28	400	1750	54	2,50	63	0	-25...+60	p. 255 / G)
*1G 140	M1G 055-BD	Ⓐ	48	36-57	410	1750	54	1,30	63	0	-25...+60	p. 255 / G)

Subject to alternations

### Curve:

U<sub>N</sub> = nominal voltage  
(24 V / 48 V)

U<sub>R</sub> = overvoltage  
(28 V / 57 V)

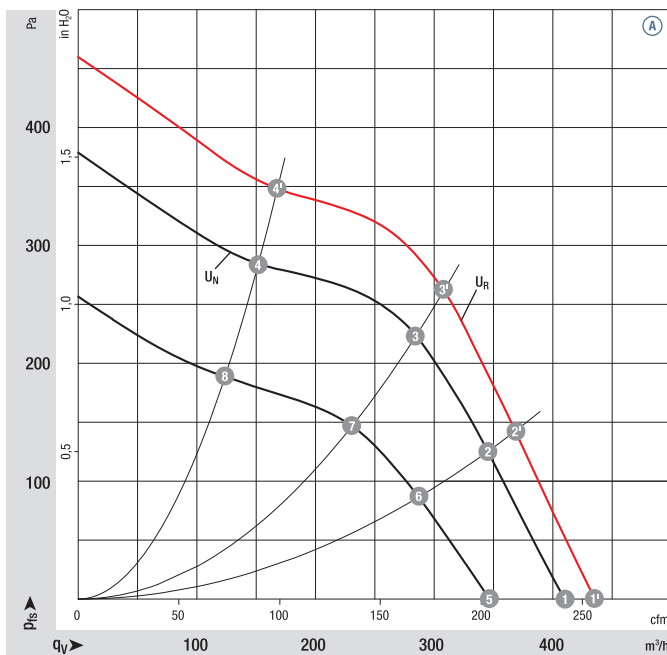

	n rpm	P <sub>ed</sub> W	Lp <sub>A</sub> dB(A)	η <sub>IL</sub> %
Ⓐ 1'	1850	65	64	—
Ⓐ 2'	2020	61	61	50
Ⓐ 3'	2200	57	59	54
Ⓐ 4'	2550	43	60	40
Ⓐ 1	1750	54	63	—
Ⓐ 2	1900	50	59	51
Ⓐ 3	2030	45	58	54
Ⓐ 4	2310	32	58	40
Ⓐ 5	1500	34	60	—
Ⓐ 6	1580	29	56	50
Ⓐ 7	1670	25	54	53
Ⓐ 8	1880	19	53	41

Air performance measured as per: ISO 5801, Installation category A, with ebm-papst inlet nozzle without protection against accidental contact. Suction-side noise levels: LWA as per ISO 13347, LpA measured at 1 m distance to fan axis. The acoustic values given are only valid under the measurement conditions listed and may vary depending on the installation situation. With any deviation to the standard setup, the specific values have to be checked and reviewed once installed or fitted! For detailed information see <http://www.ebmpapst.com/general-conditions>

- **Technical features:** See electrical connections p. 255
- **EMC:** Interference emission acc. to EN 61000-6-3  
Interference immunity acc. to EN 61000-6-2
- **Cable exit:** Axial
- **Protection class:** I
- **Product conforming to standards:** EN 60950-1
- **Approvals:** Ⓐ (48 VDC) CCC



Mass centrifugal fans

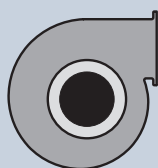

Mass centrifugal blowers

Centrifugal fans	kg	Centrifugal blowers with flange	kg
R1G 140-AV17 -02	1,0	G1G 140-AV17 -02	2,3
R1G 140-AV21 -02	1,0	G1G 140-AV21 -02	2,3

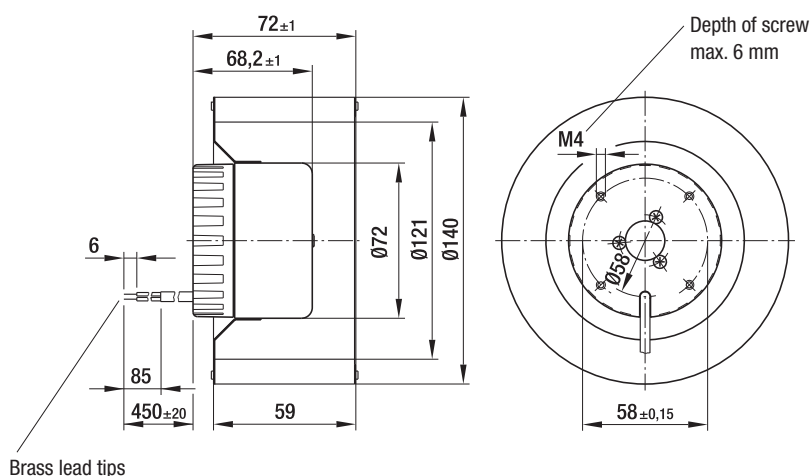

Brass lead tips

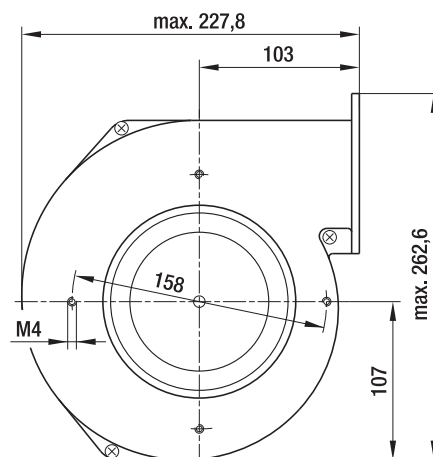
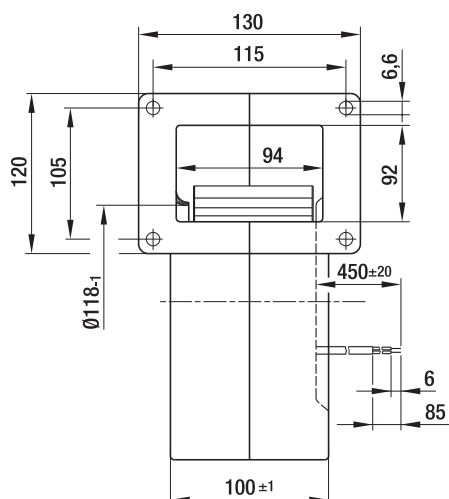

max. 470 m<sup>3</sup>/h

# DC centrifugal fans and blowers

Ø 146 mm



- **Material:** Housing: Die-cast aluminium  
Impeller: Hot-dip galvanised sheet steel  
Rotor: Galvanised
- **Direction of rotation:** Clockwise, seen on rotor
- **Type of protection:** IP 42
- **Insulation class:** "B"
- **Mounting position:** Any
- **Condensate discharges:** None
- **Operation mode:** Continuous operation (S1)
- **Bearings:** Maintenance-free ball bearings

Nominal data		Curve	Nominal voltage	Voltage range	Air flow	Speed / rpm	Input power	Current draw	Sound power level	Min. back-pressure	Perm. amb. temp.	Technical features and electrical connections
Type	Motor	VDC	VDC	m <sup>3</sup> /h	rpm	W	A	dB(A)	Pa	°C		
*1G 146	M1G 074-BF	Ⓐ	24	16-28	470	2200	100	5,00	68	0	-25...+60	p. 255 / G)
*1G 146	M1G 074-BF	Ⓐ	48	36-57	465	2150	100	2,60	67	0	-25...+60	p. 255 / G)

Subject to alternations

### Curve:

U<sub>N</sub> = nominal voltage  
(24 V / 48 V)

U<sub>R</sub> = overvoltage  
(28 V / 57 V)

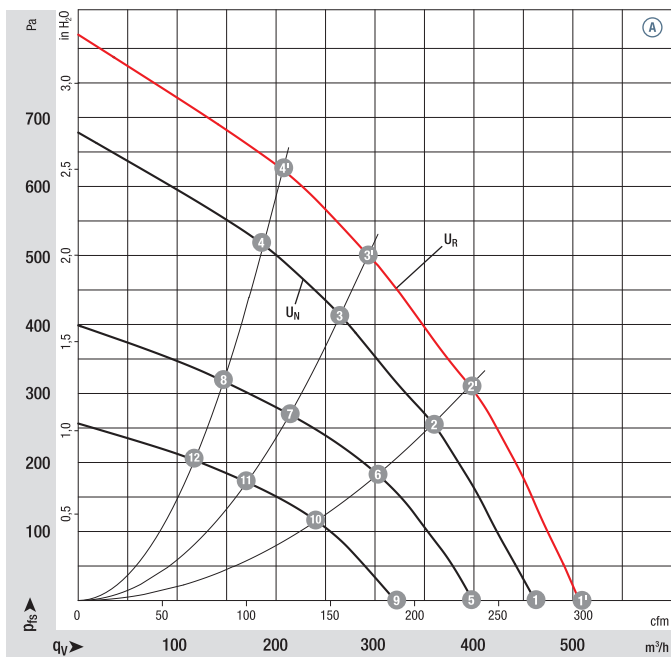

	n rpm	P <sub>ed</sub> W	Lp <sub>A</sub> dB(A)	η <sub>IL</sub> %
Ⓐ 1'	2400	140	70	—
Ⓐ 2'	2650	130	67	45
Ⓐ 3'	3000	110	66	49
Ⓐ 4'	3300	100	67	45
Ⓐ 1	2200	100	68	—
Ⓐ 2	2445	90	65	46
Ⓐ 3	2750	84	64	49
Ⓐ 4	3025	77	65	45
Ⓐ 5	1890	68	63	—
Ⓐ 6	2075	57	60	46
Ⓐ 7	2250	48	61	49
Ⓐ 8	2335	41	61	45
Ⓐ 9	1520	37	59	—
Ⓐ 10	1670	32	55	46
Ⓐ 11	1815	27	55	49
Ⓐ 12	1920	23	55	45

Air performance measured as per: ISO 5801, Installation category A, with ebm-papst inlet nozzle without protection against accidental contact. Suction-side noise levels: LWA as per ISO 13347, LpA measured at 1 m distance to fan axis. The acoustic values given are only valid under the measurement conditions listed and may vary depending on the installation situation. With any deviation to the standard setup, the specific values have to be checked and reviewed once installed or fitted! For detailed information see <http://www.ebmpapst.com/general-conditions>



- **Technical features:** See electrical connections p. 255
- **EMC:** Interference emission acc. to EN 61000-6-3  
Interference immunity acc. to EN 61000-6-2
- **Cable exit:** Axial
- **Protection class:** I
- **Product conforming to standards:** EN 60950-1
- **Approvals:** UL, CSA, CCC (only centrifugal blowers)



Mass centrifugal fans

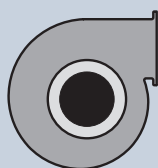

Mass centrifugal blowers

Centrifugal fans	kg	Centrifugal blowers with flange	kg
R1G 146-AA07 -52	1,4	G1G 146-BA07 -52	2,8
R1G 146-AA11 -52	1,4	G1G 146-BA11 -52	2,8

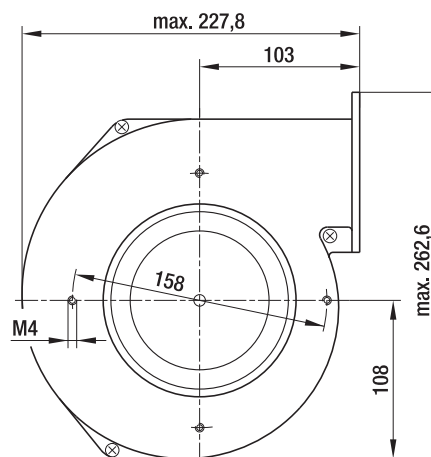
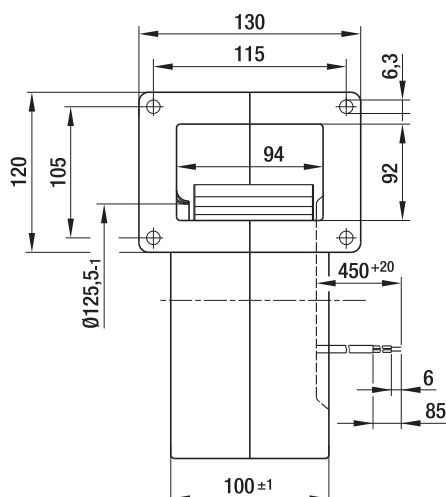
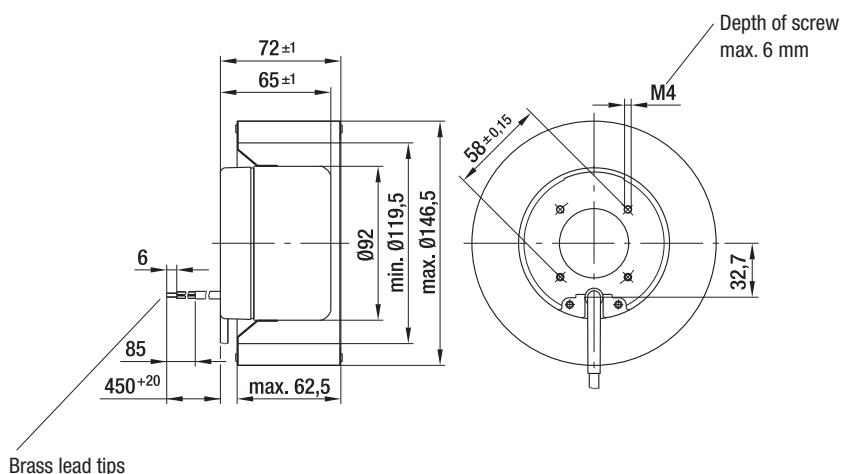

max. 505 m<sup>3</sup>/h

# DC centrifugal fans and blowers

Ø 160 mm



- **Material:** Housing: Die-cast aluminium  
Impeller: Hot-dip galvanised sheet steel  
Rotor: Galvanised
- **Direction of rotation:** Clockwise, seen on rotor
- **Type of protection:** IP 42
- **Insulation class:** "B"
- **Mounting position:** Any
- **Condensate discharges:** None
- **Operation mode:** Continuous operation (S1)
- **Bearings:** Maintenance-free ball bearings

Nominal data		Curve	Nominal voltage	Voltage range	Air flow	Speed / rpm	Input power	Current draw	Sound power level	Min. back-pressure	Perm. amb. temp.	Technical features and electrical connections
Type	Motor		VDC	VDC	m <sup>3</sup> /h	rpm	W	A	dB(A)	Pa	°C	
*1G 160	M1G 074-BF	Ⓐ	24	16-28	505	1750	105	5,80	67	0	-25...+60	p. 255 / G)
*1G 160	M1G 074-BF	Ⓐ	48	36-57	505	1750	105	2,90	67	0	-25...+60	p. 255 / G)

Subject to alternations

**Curve:**

U<sub>N</sub> = nominal voltage  
(24 V / 48 V)

U<sub>R</sub> = overvoltage  
(28 V / 57 V)

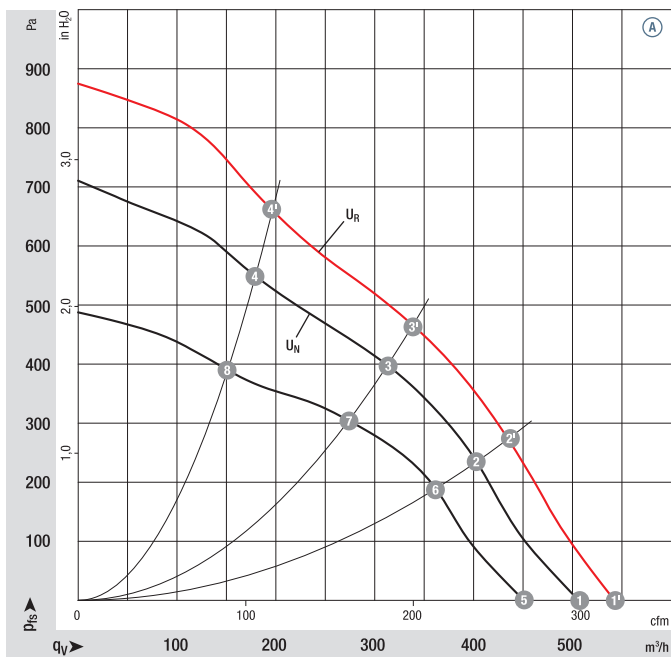

	n rpm	P <sub>ed</sub> W	Lp <sub>A</sub> dB(A)	η <sub>IL</sub> %
Ⓐ 1'	1890	134	68	—
Ⓐ 2'	2200	118	67	52
Ⓐ 3'	2500	110	67	57
Ⓐ 4'	2900	102	69	52
Ⓐ 1	1750	105	67	—
Ⓐ 2	2030	95	66	52
Ⓐ 3	2270	90	65	57
Ⓐ 4	2550	81	67	44
Ⓐ 5	1580	72	62	—
Ⓐ 6	1810	66	62	52
Ⓐ 7	2000	58	62	57
Ⓐ 8	2200	48	63	54

Air performance measured as per: ISO 5801, Installation category A, with ebm-papst inlet nozzle without protection against accidental contact. Suction-side noise levels: LWA as per ISO 13347, LpA measured at 1 m distance to fan axis. The acoustic values given are only valid under the measurement conditions listed and may vary depending on the installation situation. With any deviation to the standard setup, the specific values have to be checked and reviewed once installed or fitted! For detailed information see <http://www.ebmpapst.com/general-conditions>

- **Technical features:** See electrical connections p. 255
- **EMC:** Interference emission acc. to EN 61000-6-3  
Interference immunity acc. to EN 61000-6-2
- **Cable exit:** Axial
- **Protection class:** I
- **Product conforming to standards:** EN 60950-1
- **Approvals:** UL, CSA



Mass centrifugal fans



Mass centrifugal blowers

Centrifugal fans	kg	Centrifugal blowers with flange	kg
R1G 160-AH29 -52	1,4	G1G 160-BH29 -52	2,8
R1G 160-AH39 -52	1,4	G1G 160-BH39 -52	2,8

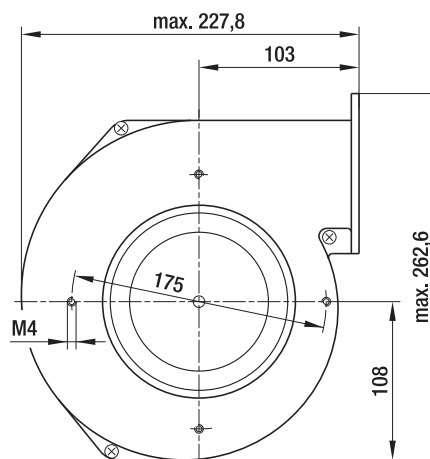
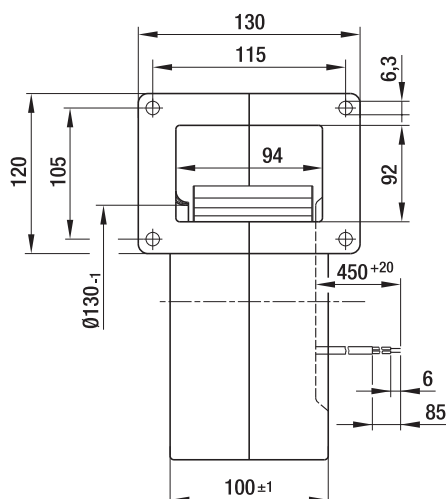
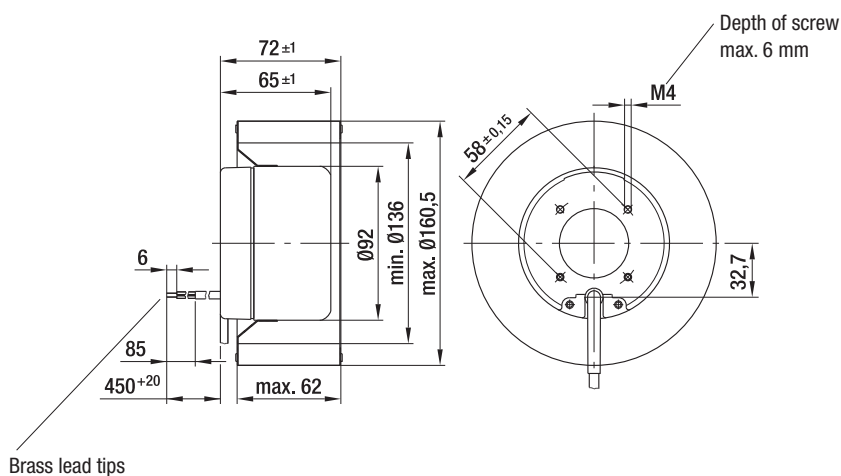

max. 700 m<sup>3</sup>/h

# DC Centrifugal blowers

Ø 133 mm



- **Material:** Housing: Galvanised sheet steel  
Impeller: Galvanised sheet steel  
Rotor: Coated in black
- **Direction of rotation:** Clockwise, seen on rotor
- **Type of protection:** IP 42
- **Insulation class:** "B"
- **Mounting position:** Any
- **Condensate discharges:** None
- **Operation mode:** Continuous operation (S1)
- **Design:** Standard external-rotor motor anti-vibration mounted on both sides
- **Bearings:** Maintenance-free ball bearings

Nominal data		Curve	Nominal voltage	Voltage range	Air flow	Speed / rpm	Input power	Current draw	Sound power level	Min. back-pressure	Perm. amb. temp.	Technical features and electrical connections
Type	Motor	VDC	VDC	m <sup>3</sup> /h	rpm	W	A	dB(A)	Pa	°C		
<b>D1G 133</b>	M1G 074-BF	Ⓐ	24	16-28	700	1780	105	5,60	62	50	-25...+60	p. 255 / G)
<b>D1G 133</b>	M1G 074-BF	Ⓐ	48	36-57	700	1780	105	2,80	62	50	-25...+60	p. 255 / G)

Subject to alternations

**Curve:**

U<sub>N</sub> = nominal voltage  
(24 V / 48 V)

U<sub>R</sub> = overvoltage  
(28 V / 57 V)

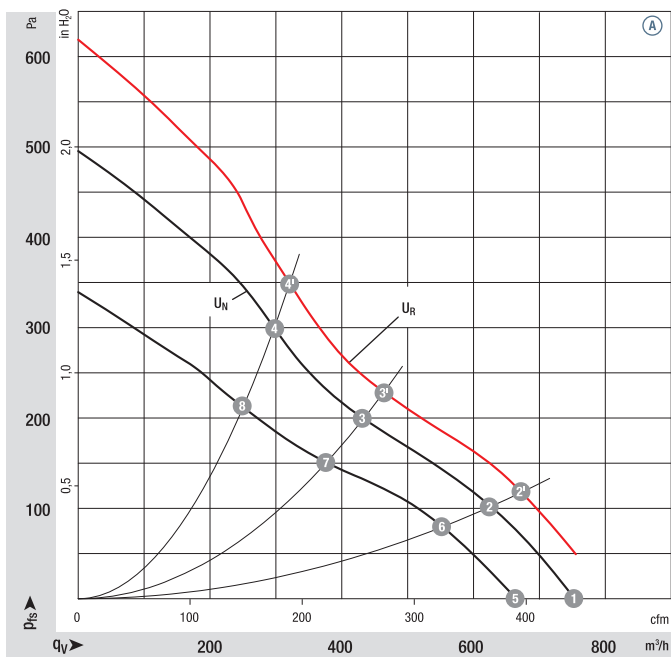

	n rpm	P <sub>ed</sub> W	Lp <sub>A</sub> dB(A)	η <sub>IL</sub> %
Ⓐ 1'	—	—	—	—
Ⓐ 2'	2050	121	63	49
Ⓐ 3'	2490	106	62	41
Ⓐ 4'	2820	100	62	37
Ⓐ 1	1780	105	62	—
Ⓐ 2	1900	97	61	49
Ⓐ 3	2310	86	59	41
Ⓐ 4	2630	80	60	37
Ⓐ 5	1500	73	59	—
Ⓐ 6	1720	67	57	49
Ⓐ 7	2020	58	56	41
Ⓐ 8	2230	49	56	37

Air performance measured as per: ISO 5801, Installation category A, with ebm-papst inlet nozzle without protection against accidental contact. Suction-side noise levels: LWA as per ISO 13347, LpA measured at 1 m distance to fan axis. The acoustic values given are only valid under the measurement conditions listed and may vary depending on the installation situation. With any deviation to the standard setup, the specific values have to be checked and reviewed once installed or fitted! For detailed information see <http://www.ebmpapst.com/general-conditions>

- **Technical features:** See electrical connections p. 255
- **EMC:** Interference emission acc. to EN 61000-6-3  
Interference immunity acc. to EN 61000-6-2
- **Cable exit:** Variabel
- **Protection class:** I
- **Product conforming to standards:** EN 60950-1
- **Approvals:** UL, CSA; ⓐ (48 VDC) auch CCC

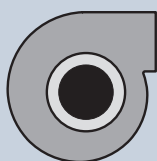
Mass  
centrifugal blowersCentrifugal blowers  
without flange

kg

D1G 133-AB29 -52

3,3

D1G 133-AB39 -52

3,3

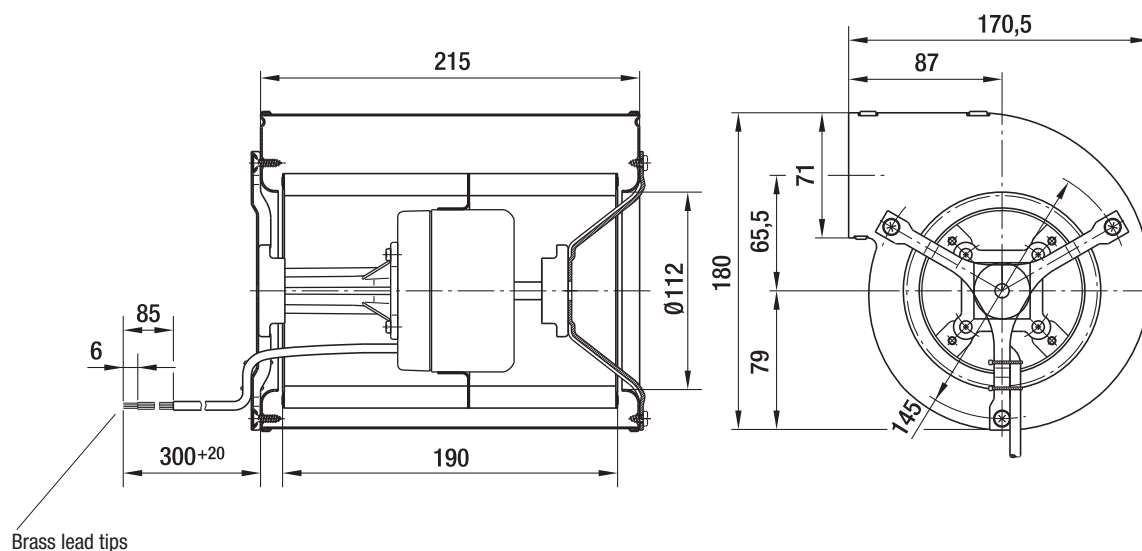

max. 1020 m<sup>3</sup>/h

# DC Centrifugal blowers

Ø 133 mm

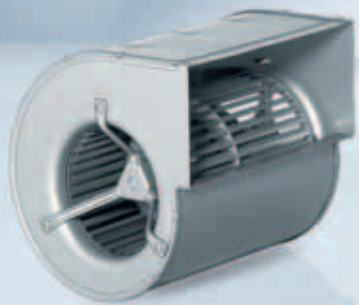

- **Material:** Housing: Galvanised sheet steel  
Impeller: Galvanised sheet steel  
Rotor: Coated in black
- **Direction of rotation:** Clockwise, seen on rotor
- **Type of protection:** IP 42
- **Insulation class:** "B"
- **Mounting position:** Any
- **Condensate discharges:** None
- **Operation mode:** Continuous operation (S1)
- **Design:** Standard external-rotor motor anti-vibration mounted on both sides
- **Bearings:** Maintenance-free ball bearings

Nominal data		Curve	Nominal voltage	Voltage range	Air flow	Speed / rpm	Input power	Current draw	Sound power level	Min. back-pressure	Perm. amb. temp.	Technical features and electrical connections
Type	Motor	VDC	VDC	m <sup>3</sup> /h	rpm	W	A	dB(A)	Pa	°C		
<b>D1G 133</b>	M1G 074-BF	Ⓐ	24	16-28	1020	1580	118	6,00	64	0	-25...+60	p. 255 / G)
<b>D1G 133</b>	M1G 074-BF	Ⓐ	48	36-57	1020	1580	118	3,00	64	0	-25...+60	p. 255 / G)

Subject to alternations

**Curve:**

U<sub>N</sub> = nominal voltage  
(24 V / 48 V)

U<sub>R</sub> = overvoltage  
(28 V / 57 V)

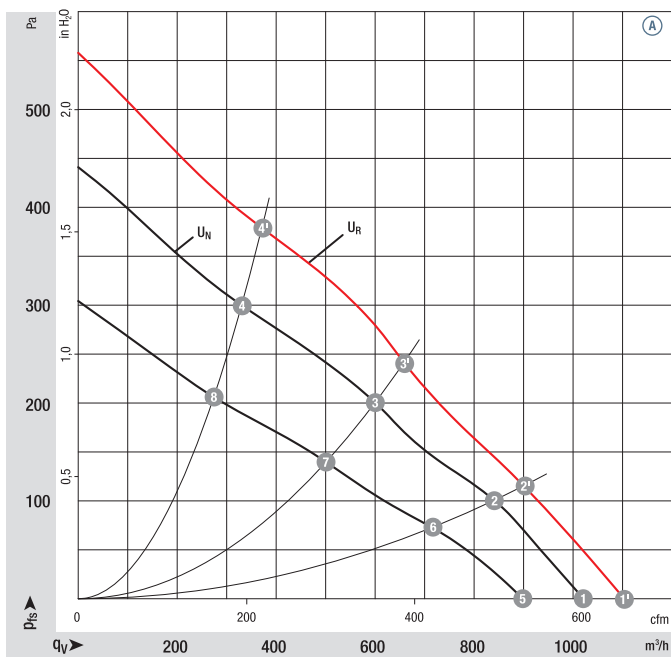

	n rpm	P <sub>ed</sub> W	Lp <sub>A</sub> dB(A)	η <sub>IL</sub> %
Ⓐ 1'	1700	145	65	—
Ⓐ 2'	1930	133	62	38
Ⓐ 3'	2290	122	59	41
Ⓐ 4'	2700	99	61	32
Ⓐ 1	1580	118	64	—
Ⓐ 2	1790	107	61	38
Ⓐ 3	2100	95	57	41
Ⓐ 4	2410	73	58	32
Ⓐ 5	1400	78	60	—
Ⓐ 6	1580	70	56	38
Ⓐ 7	1760	56	53	41
Ⓐ 8	2000	44	53	32

Air performance measured as per: ISO 5801, Installation category A, with ebm-papst inlet nozzle without protection against accidental contact. Suction-side noise levels: LWA as per ISO 13347, LpA measured at 1 m distance to fan axis. The acoustic values given are only valid under the measurement conditions listed and may vary depending on the installation situation. With any deviation to the standard setup, the specific values have to be checked and reviewed once installed or fitted! For detailed information see <http://www.ebmpapst.com/general-conditions>



- **Technical features:** See electrical connections p. 255
- **EMC:** Interference emission acc. to EN 61000-6-3  
Interference immunity acc. to EN 61000-6-2
- **Cable exit:** Variabel
- **Protection class:** I
- **Product conforming to standards:** EN 60950-1
- **Approvals:** UL, CSA

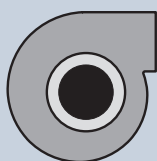

Mass centrifugal blowers

Centrifugal blowers without flange

kg

D1G 133-DC13 -52	3,4
D1G 133-DC17 -52	3,4

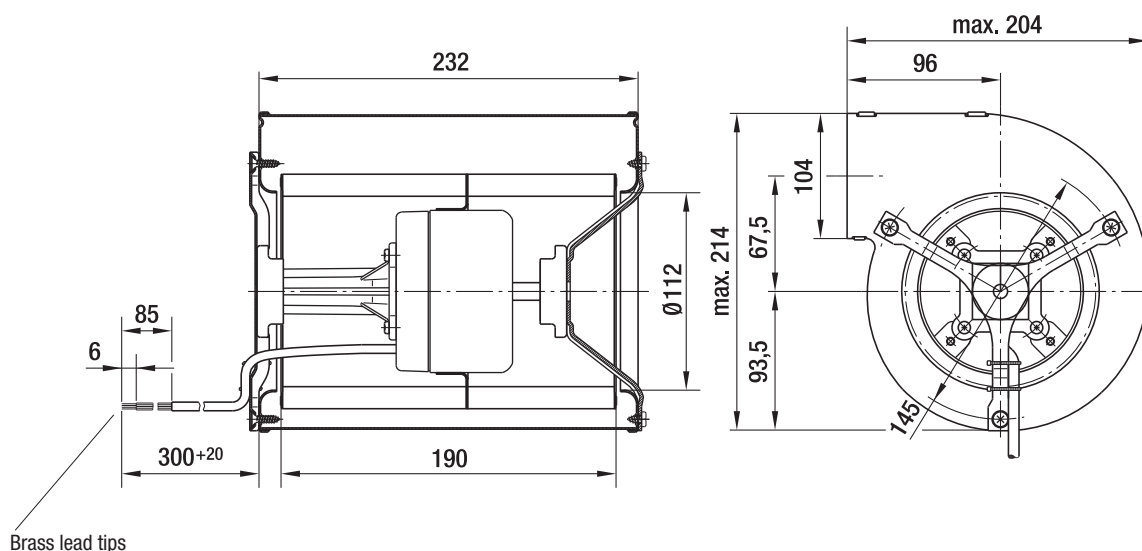

max. 1000 m<sup>3</sup>/h

# DC Centrifugal blowers

Ø 146 mm



- **Material:** Housing: Galvanised sheet steel  
Impeller: Galvanised sheet steel  
Rotor: Coated in black
- **Direction of rotation:** Clockwise, seen on rotor
- **Type of protection:** IP 42
- **Insulation class:** "B"
- **Mounting position:** Any
- **Condensate discharges:** None
- **Operation mode:** Continuous operation (S1)
- **Design:** Standard external-rotor motor anti-vibration mounted on both sides
- **Bearings:** Maintenance-free ball bearings

Nominal data		Curve	Nominal voltage	Voltage range	Air flow	Speed / rpm	Input power	Current draw	Sound power level	Min. back-pressure	Perm. amb. temp.	Technical features and electrical connections
Type	Motor	VDC	VDC	m <sup>3</sup> /h	rpm	W	A	dB(A)	Pa	°C		
<b>D1G 146</b>	M1G 074-CF	Ⓐ	24	16-28	1000	1350	105	5,10	61	0	-25...+60	p. 255 / G)
<b>D1G 146</b>	M1G 074-CF	Ⓐ	48	36-57	1000	1350	105	2,60	61	0	-25...+60	p. 255 / G)

Subject to alternations

**Curve:**

U<sub>N</sub> = nominal voltage  
(24 V / 48 V)

U<sub>R</sub> = overvoltage  
(28 V / 57 V)

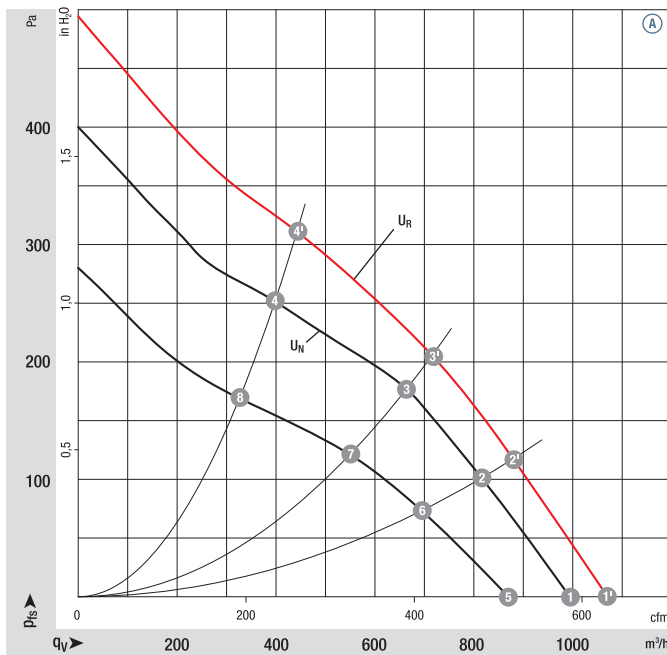

	n rpm	P <sub>ed</sub> W	Lp <sub>A</sub> dB(A)	η <sub>IL</sub> %
Ⓐ 1'	1460	129	63	—
Ⓐ 2'	1680	119	60	53
Ⓐ 3'	1890	111	58	61
Ⓐ 4'	2240	95	59	55
Ⓐ 1	1350	105	61	—
Ⓐ 2	1570	95	58	53
Ⓐ 3	1750	88	56	61
Ⓐ 4	2010	70	57	55
Ⓐ 5	1210	70	56	—
Ⓐ 6	1360	60	54	53
Ⓐ 7	1460	53	52	61
Ⓐ 8	1670	42	51	55

Air performance measured as per: ISO 5801, Installation category A, with ebm-papst inlet nozzle without protection against accidental contact. Suction-side noise levels: LWA as per ISO 13347, LpA measured at 1 m distance to fan axis. The acoustic values given are only valid under the measurement conditions listed and may vary depending on the installation situation. With any deviation to the standard setup, the specific values have to be checked and reviewed once installed or fitted! For detailed information see <http://www.ebmpapst.com/general-conditions>

- **Technical features:** See electrical connections p. 255
- **EMC:** Interference emission acc. to EN 61000-6-3  
Interference immunity acc. to EN 61000-6-2
- **Cable exit:** Variabel
- **Protection class:** I
- **Product conforming to standards:** EN 60950-1
- **Approvals:** UL, CSA

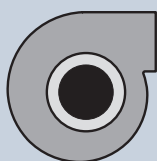
Mass  
centrifugal blowersCentrifugal blowers  
without flange

kg

D1G 146-AA19 -52

3,5

D1G 146-AA33 -52

3,5

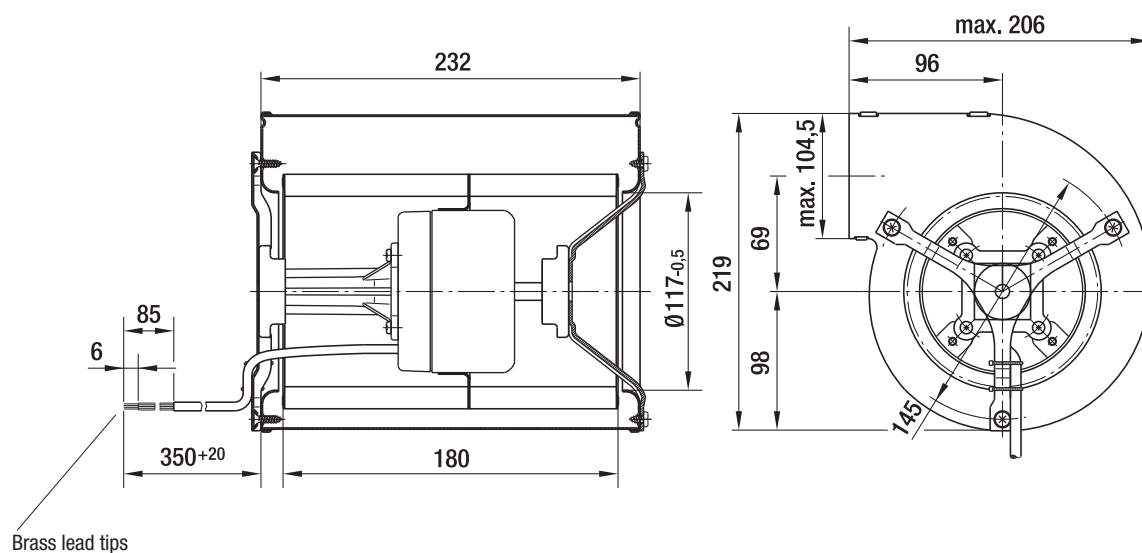

max. 980 m<sup>3</sup>/h

# DC Centrifugal blowers

Ø 160 mm



- **Material:** Housing: Galvanised sheet steel  
Impeller: Galvanised sheet steel  
Rotor: Coated in black
- **Direction of rotation:** Clockwise, seen on rotor
- **Type of protection:** IP 42
- **Insulation class:** "B"
- **Mounting position:** Any
- **Condensate discharges:** None
- **Operation mode:** Continuous operation (S1)
- **Design:** Standard external-rotor motor anti-vibration mounted on both sides
- **Bearings:** Maintenance-free ball bearings

Nominal data		Curve	Nominal voltage	Voltage range	Air flow	Speed / rpm	Input power	Current draw	Sound power level	Min. back-pressure	Perm. amb. temp.	Technical features and electrical connections
Type	Motor	VDC	VDC	m <sup>3</sup> /h	rpm	W	A	dB(A)	Pa	°C		
D1G 160	M1G 074-CF	Ⓐ	24	16-28	980	1250	112	5,60	60	0	-25...+60	p. 255 / G)
D1G 160	M1G 074-CF	Ⓐ	48	36-57	980	1250	112	2,90	60	0	-25...+60	p. 255 / G)

Subject to alternations

**Curve:**

U<sub>N</sub> = nominal voltage  
(24 V / 48 V)

U<sub>R</sub> = overvoltage  
(28 V / 57 V)

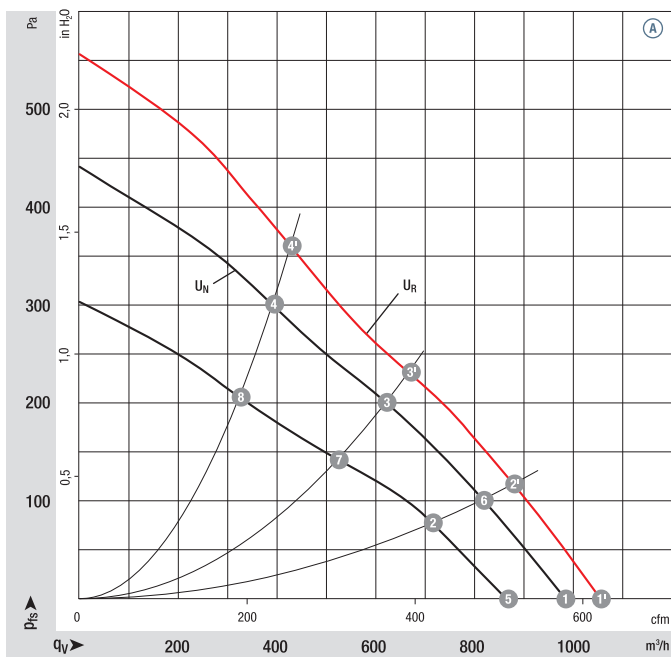

	n rpm	P <sub>ed</sub> W	Lp <sub>A</sub> dB(A)	η <sub>IL</sub> %
Ⓐ 1'	1330	142	63	—
Ⓐ 2'	1520	128	61	64
Ⓐ 3'	1790	115	59	66
Ⓐ 4'	2090	105	60	60
Ⓐ 1	1250	112	60	—
Ⓐ 2	1420	102	59	64
Ⓐ 3	1660	92	58	66
Ⓐ 4	1900	80	58	60
Ⓐ 5	1100	75	58	—
Ⓐ 6	1250	69	56	64
Ⓐ 7	1420	58	54	66
Ⓐ 8	1580	47	53	60

Air performance measured as per: ISO 5801, Installation category A, with ebm-papst inlet nozzle without protection against accidental contact. Suction-side noise levels: LWA as per ISO 13347, LpA measured at 1 m distance to fan axis. The acoustic values given are only valid under the measurement conditions listed and may vary depending on the installation situation. With any deviation to the standard setup, the specific values have to be checked and reviewed once installed or fitted! For detailed information see <http://www.ebmpapst.com/general-conditions>

- **Technical features:** See electrical connections p. 255
- **EMC:** Interference emission acc. to EN 61000-6-3  
Interference immunity acc. to EN 61000-6-2
- **Cable exit:** Variabel
- **Protection class:** I
- **Product conforming to standards:** EN 60950-1
- **Approvals:** UL, CSA

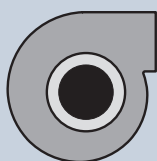

Mass  
centrifugal blowers

Centrifugal blowers  
without flange

kg

D1G 160-DA19 -52

3,6

D1G 160-DA33 -52

3,6

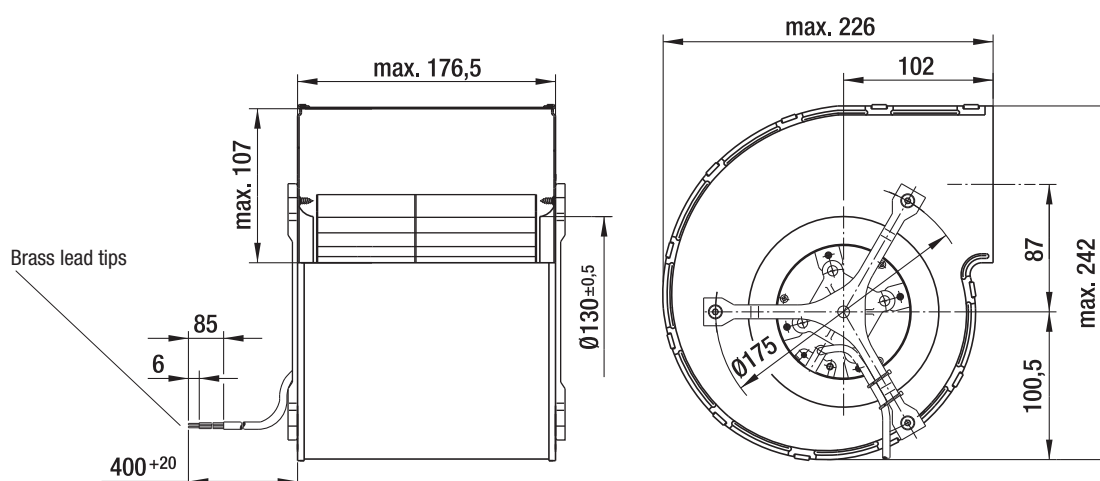





# DC fans - specials



Speed signal	164
Alarm signal	168
Vario-Pro / Speed setting / Control input	173
Protection against ambient influences, Protection class IP 54 / IP 68	177

## Technical information



### Cooling capacity and efficiency

Greater power density, increasing miniaturisation and extreme electronic component density are posing increased demands on the cooling capacity and efficiency of fans. The intelligent and space-saving integration of the fan in the device configuration is therefore of major importance:

- Tailor-made cooling adapted to the situation as and when required.
- Programmable cooling by defining speed profiles.
- Transparency of function thanks to complete, interactive monitoring in all operating conditions.

Standard fans in electronics cooling have proven themselves millions of times.

With a constant speed and a correspondingly high noise level, they continuously provide the air flow needed for extreme cases. These extreme situations, however, occur extremely rarely, if at all, during the operating period. An intelligent fan is needed, which adapts automatically to the currently required level of cooling.

ebm-papst provides intelligent cooling concepts which are optimally adapted to requirements. For example:

### 1. Speed adjustment via temperature sensor

ebm-papst answers with a complete range of DC fans with temperature-controlled speed adjustment via a temperature sensor, available in a variety of standard dimensions.

Installation is very simple. The control electronics receive thermal information for the speed adjustment continuously and without losses, either externally via a freely designed and positionable strand, or internally directly in the fan hub in the air flow. A range of temperature sensors can be found on page 174.

### 2. DC fans with separate control input

Open or closed-loop speed control is also possible with DC fans that have a separate control input. A variation in speed can thus be implemented via a control voltage or a pulse-width modulated signal. These possibilities are used primarily in devices that have appropriate standard interfaces and thus require a load-dependent variation of the fans.

## Technical information



### 3. Speed signal

DC fans with speed signal.

The integrated „electronic tachometer“ continuously provides an actual speed signal for external evaluation. The user is informed at all times of the current fan speed via an extremely simple signal evaluation on the customer side. The speed signal is via a separate lead.

### 4. Alarm signal

For applications which require monitored fan operation with alarm signal, ebm-papst has numerous alarm signal versions, either a static, pre-processed or interface-compatible high or low continuous signal depending on the type of fan.

### 5. Turbo drives

Fans with three-phase EC drives and microprocessor-controlled motor electronics. These three-phase motors whose torque is virtually non-reliant on the rotor position are used for extremely high running smoothness. The speed of these fans can be controlled over a very wide range with PWM, analogue voltage or temperature. Optionally, the fans can be supplied with reversible direction of rotation and active brake operation.

### 6. Vario-Pro fans

This high-end fan concept by ebmpapst with programmed intelligence and customer-specific integrated functions makes your electronics cooling even more versatile and competitive. Vario-Pro ensures a fresh economic breeze for all demanding cooling tasks – e.g. where greater reliability, more flexibility and intelligent function features such as alarm function, speed control etc. are required.

The successful concept of Vario-Pro is: Tailor-made software instead of fixed hardware, because programmed software modules for motor control and application intelligence are responsible for the work that analogue components were responsible for in the past. This central control unit of the Vario-Pro comprises a microcontroller and an EEPROM, on which all characteristics are stored.

### 7. Protection against environmental influences

Some applications place particular demands on the fans resistance to ambient influences, such as dust, moisture, water and salt. ebm-papst offer solutions for adapting fans to these ambient conditions.

# Speed signal /2

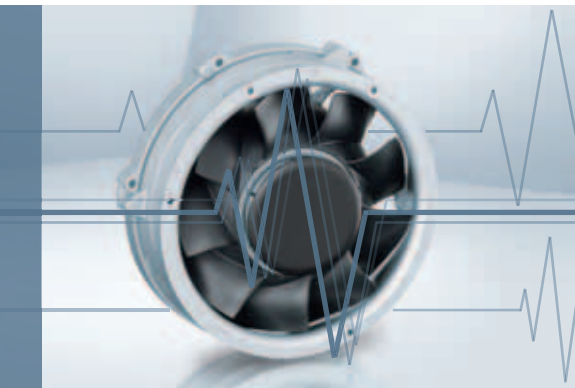

- Speed-proportional rectangular pulse for external speed monitoring of fan motor
- 2, 3 or 6 pulses per revolution
- Open collector signal output
- Extremely wide operating voltage range
- Easy adaptation to user interface
- Connection via separate lead
- The sensor signal also serves as a major comparison variable for setting and maintaining the setpoint speed for interactive or controlled cooling with one or several interconnected fans.

## Electrical connection

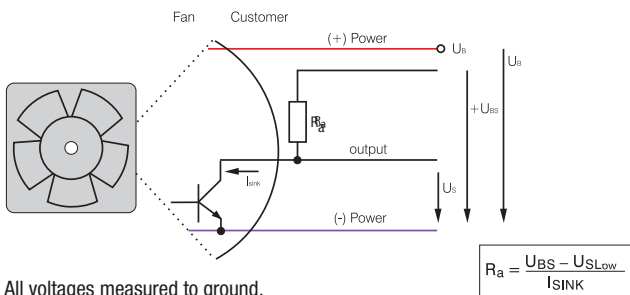

All voltages measured to ground.  
External load resistor  $R_a$  /  $U_S$  /  $U_{BS}$  required.

## Signal output voltage

Standard signal for all models (exceptions see below)

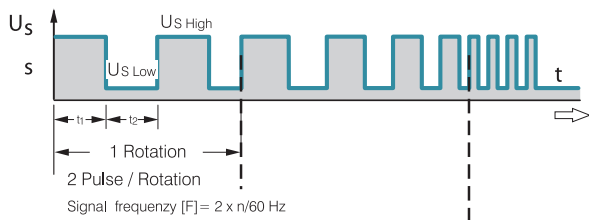

only for 4100 NH7 and NH8

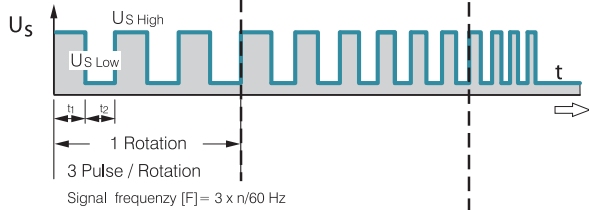

Allé TD Lüfter. Bsp.: 6400 TD

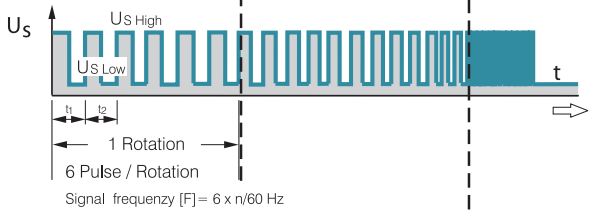

## Fan Speed

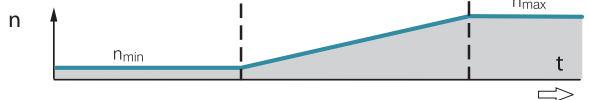

Signal data	Speed signal $U_{S\text{Low}}$	Condition: Isink	Speed signal $U_{S\text{High}}$	Condition: Isource	Sensor operating voltage $U_{BS\text{max}}$	Perm. sink current $I_{\text{sink max}}$	Pulses per revolution	Fan description	Basic type
	Type	VDC	mA	VDC	mA	VDC	mA	Page	
250	$\leq 0,4$	2	$\leq 30$	0	30	2	2	31	
400 F	$\leq 0,4$	1	$\leq 30$	0	30	2	2	32	
400	$\leq 0,4$	1	$\leq 30$	0	30	2	2	33	
420 J	$\leq 0,4$	2	$\leq 15$	0	15	4	2	34	
500 F	$\leq 0,4$	1	$\leq 30$	0	30	2	2	35	
600 F	$\leq 0,4$	1	$\leq 30$	0	30	2	2	36	
620	$\leq 0,4$	2	$\leq 30$	0	30	4	2	37	
630 U	$\leq 0,4$	2	$\leq 30$	0	30	4	2	38	
600 N	$\leq 0,4$	2	$\leq 28$	0	28	4	2	39	
600 J	$\leq 0,4$	2	$\leq 30$	0	30	4	2	41	
700 F	$\leq 0,4$	2	$\leq 30$	0	30	4	2	42	
8450	$\leq 0,4$	2	$\leq 28$	0	28	4	2	43	
8400 N	$\leq 0,4$	2	$\leq 28$	0	28	4	2	44	
8400 N VARIOFAN	$\leq 0,4$	2	$\leq 30$	0	30	4	2	45	
8300	$\leq 0,4$	2	$\leq 30$	0	30	4	2	46	
8200 J	$\leq 0,4$	2	$\leq 30$	0	30	4	2	47	
3400 N	$\leq 0,4$	2	$\leq 28$	0	28	4	2	48	
3400 N VARIOFAN	$\leq 0,4$	2	$\leq 30$	0	30	4	2	49	
3300	$\leq 0,4$	2	$\leq 30$	0	30	4	2	50	
3300 N	$\leq 0,4$	2	$\leq 30$	0	30	4	2	51	
3212 J / 3214 J	$\leq 0,4$	2	$\leq 30$	0	30	4	2	52	
3218 J	$\leq 0,4$	2	$\leq 60$	0	60	4	2	52	
3250 J	$\leq 0,4$	2	$\leq 60$	0	60	4	3	53	
4412 F / 4414 F	$\leq 0,4$	2	$\leq 30$	0	30	4	2	54	
4418 F	$\leq 0,4$	2	$\leq 60$	0	60	4	2	54	
4400 FN	$\leq 0,4$	2	$\leq 30$	0	30	4	2	55	
4312 / 4314	$\leq 0,4$	2	$\leq 30$	0	30	4	2	56	
4318	$\leq 0,4$	2	$\leq 60$	0	60	4	2	56	
4312 / 4314 VARIOFAN	$\leq 0,4$	2	$\leq 30$	0	30	4	2	57	
4318 VARIOFAN	$\leq 0,4$	2	$\leq 60$	0	60	4	2	57	
4400	$\leq 0,4$	2	$\leq 30$	0	30	4	2	58/59	
4100 N	$\leq 0,4$	2	$\leq 30$	0	30	4	2	60	
4100 NHH...NH6	$\leq 0,4$	2	$\leq 60$	0	60	10	2	61	
4100 NH7...NH8	$\leq 0,4$	2	$\leq 60$	0	60	20	3	62	
DV 4100	$\leq 0,4$	2	$\leq 30$	0	30	4	2	63	

Subject to alternations

**Available on request:**

- Electrically isolated sensor and signal circuit
- Varying voltage potentials for power and logic circuit

Signal data	Speed signal U <sub>S</sub> Low	Condition: !sink	Speed signal U <sub>S</sub> High	Condition: !source	Sensor operating voltage U <sub>GS</sub> max.	Perm. sink current I <sub>sink</sub> max.	Pulses per revolution	Fan description Basic type
Type	VDC	mA	VDC	mA	VDC	mA		Page
5200 N	≤ 0,4	2	≤ 30	0	30	4	2	64
DV 5200	≤ 0,4	2	≤ 30	0	30	4	2	65
5112 N	≤ 0,4	2	≤ 15	0	5	20	2	66
5114 N / 5118 N	≤ 0,4	2	≤ 60	0	60	20	2	66
5300	≤ 0,4	2	≤ 72	0	72	4	2	67
5300 TD	≤ 0,4	2	≤ 72	0	72	20	6	68
7112 N / 7118 N	≤ 0,4	2	≤ 60	0	60	20	2	69
7114 N	≤ 0,4	2	≤ 30	0	30	20	2	69
7200 N	≤ 0,4	2	≤ 15	0	15	20	2	70
6300	≤ 0,4	2	≤ 72	0	72	20	2	72
6300 TD	≤ 0,4	2	≤ 72	0	72	20	6	73/74
DV 6300	≤ 0,4	2	≤ 72	0	72	20	6	75
6400	≤ 0,4	2	≤ 60	0	60	20	2	76
2200 FTD	≤ 0,4	2	≤ 72	0	72	20	6	80
RL 48	≤ 0,4	2	≤ 30	0	30	4	2	95
RL 65	≤ 0,4	2	≤ 30	0	30	4	2	96
RL 90 N	≤ 0,4	2	≤ 30	0	30	4	2	97
RLF 100	≤ 0,4	2	≤ 30	0	30	4	2	98
RG 90 N	≤ 0,4	2	≤ 30	0	30	4	2	99
RG 125 N	≤ 0,4	2	≤ 30	0	30	4	2	100
RG 160 N	≤ 0,4	2	≤ 30	0	30	20	2	101
RG 160 NTD	≤ 0,4	2	≤ 60	0	60	20	6	102
RG 190 TD	≤ 0,4	2	≤ 72	0	72	20	6	103
RG 220 TD	≤ 0,4	2	≤ 72	0	72	20	6	104
RG 225 TD	≤ 0,4	2	≤ 72	0	72	20	6	105
RET 97 TD	≤ 0,4	2	≤ 72	0	72	20	6	106
REF 100	≤ 0,4	2	≤ 30	0	30	4	2	107
RER 120 TD	≤ 0,4	2	≤ 72	0	72	20	6	109
RER 133 TD	≤ 0,4	2	≤ 72	0	72	20	6	113
RER 160 NTD	≤ 0,4	2	≤ 60	0	60	20	6	115
REF 175 TD	≤ 0,4	2	≤ 72	0	72	20	6	116
RER 175 TD	≤ 0,4	2	≤ 72	0	72	20	6	117
RER 190 TD	≤ 0,4	2	≤ 72	0	72	20	6	118
RER 220 TD	≤ 0,4	2	≤ 72	0	72	20	6	124
RER 225 TD	≤ 0,4	2	≤ 72	0	72	20	6	125

Subject to alternations

**Note:**

With these fan options, deviations in regard to temperature range, voltage range and power consumption are possible compared with standard fan data.

# Speed signal /12

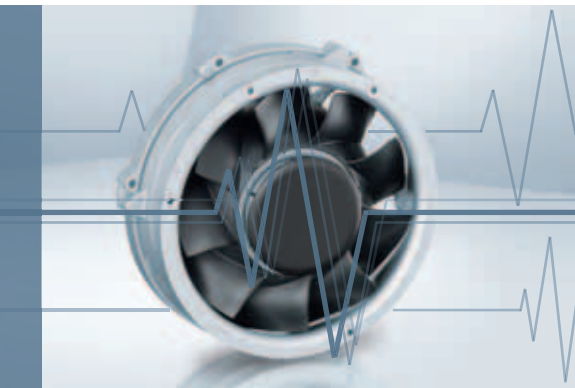

- Speed-proportional rectangular pulse for external speed monitoring of fan motor
- 2, 3 or 6 pulses per revolution
- TTL-compatible
- Integrated pull-up resistor
- Connection via separate lead
- The sensor signal also serves as a major comparison variable for setting and maintaining the setpoint speed for interactive or controlled cooling with one or more interconnected fans.

## Electrical connection

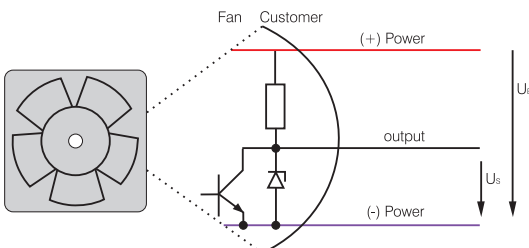

All voltages measured to ground.

## Signal output voltage

Standard signal for all models (exceptions see below)

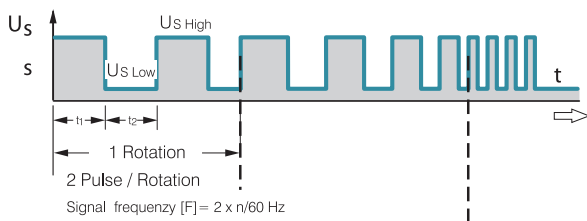

only for 4100 NH7 and NH8

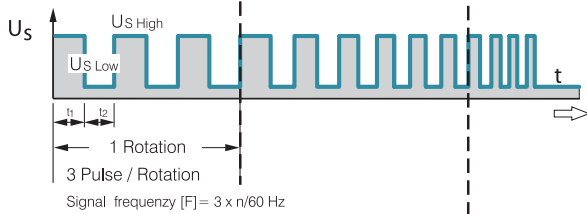

Alle TD Lüfter. Bsp.: 6400 TD

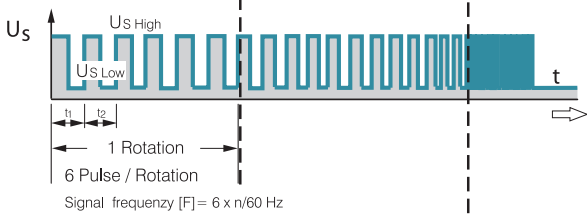

Fan Speed

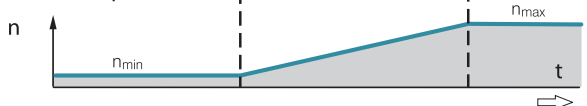

## Signal data

Type	Speed signal U <sub>S</sub> Low VDC	Condition: I <sub>sink</sub> mA	Speed signal U <sub>S</sub> High VDC	Condition: I <sub>source</sub> mA	Perm. sink current I <sub>sink</sub> max. mA	Fan description Basic type Page
614 N/12 GM	≤ 0,4	1	2,5–5,5	1	1	39
618 N/12 N	≤ 0,4	1	2,5–5,5	1	1	39
8412 N/12 H	≤ 0,4	1	2,5–5,5	1	1	44
4412 F/12 GM	≤ 0,4	1	2,5–5,5	1	1	54
4418 F/12	≤ 0,4	1	2,5–5,5	1	1	54
4312 /12 M	≤ 0,4	1	2,5–5,5	1	1	56
4314 /12	≤ 0,4	1	2,5–5,5	1	1	56
4182 N/12 X	≤ 0,4	1	2,5–5,5	1	1	60

Subject to alternations

## Note:

With these fan options, deviations in regard to temperature range, voltage range and power consumption are possible compared with standard fan data.

**Available on request:**

- Electrically isolated sensor and signal circuit
- Varying voltage potentials for power and logic circuit

Signal data	Speed signal U <sub>S</sub> Low	Condition: I <sub>sink</sub>	Speed signal U <sub>S</sub> High	Condition: I <sub>source</sub>	Perm. sink current I <sub>sink</sub> max.	Fan description Basic type
Type	VDC	mA	VDC	mA	mA	Page
7214 N/12	≤0,4	2	2,5–5,5	1	≤20	70
6424/12 H	≤0,4	2	2,5–5,5	1	≤20	76
DV 6424/12	≤0,4	2	4,5–5,25	2	≤12	78
DV 6448/12	≤0,4	2	4,5–5,25	2	≤12	78
RG 125-19/12 N/12	≤0,4	1	2,5–5,5	1	≤1	100
RG 160-28/12 N/12	≤0,4	2	2,5–5,5	1	≤5	101
RG 160-28/18 N/12	≤0,4	2	2,5–5,5	1	≤20	101
RER 125-19/12 N/12	≤0,4	1	2,5–5,5	1	≤1	112
RER 160-28/12 N/12	≤0,4	2	2,5–5,5	1	≤5	114
RER 160-28/18 N/12	≤0,4	2	2,5–5,5	1	≤20	114

Subject to alternations

**Note:**

With these fan options, deviations in regard to temperature range, voltage range and power consumption are possible compared with standard fan data.



# Alarm signal /17

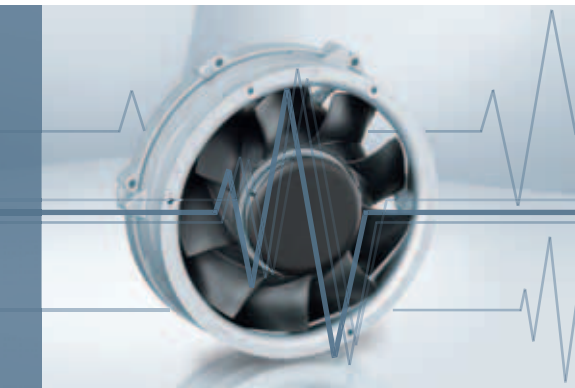

- Alarm signal for speed monitoring
- Signal output via open collector
- The fan emits a high continuous signal during trouble-free operation within the permissible voltage range.
- Low signal when speed limit is not reached
- After elimination of fault, the fan returns to its setpoint speed; the alarm signal reverts to high.

Alarm signal data	Alarm output voltage $U_{A\text{ Low}}$	Condition:	Condition: $I_{\text{sink}} =$	Alarm output-voltage $U_{A\text{ High}}$	Condition:	Condition: $I_{\text{source}}$	Alarm operating-voltage $U_{BA\text{ max.}}$	Max. permissible Sink current	Alarm delay time $t_2$	Condition:	Speed limit $n_G$	Fan description Basic type
Type	VDC		mA	VDC		mA	VDC	mA	s		RPM	Page
8318 /17	$\leq 0,4$	$n < n_G$	2	$\leq 60$	$n > n_G$	0	60	20	$\leq 15$	*	$1500 \pm 100$	46
8318 /17 H	$\leq 0,4$	$n < n_G$	2	$\leq 60$	$n > n_G$	0	60	20	$\leq 15$	*	$1500 \pm 100$	46
3314 /17	$\leq 0,4$	$n < n_G$	2	$\leq 60$	$n > n_G$	0	60	20	$\leq 15$	*	$1500 \pm 100$	50
4318 /17	$\leq 0,4$	$n < n_G$	2	$\leq 60$	$n > n_G$	0	60	20	$\leq 15$	*	$850 \pm 100$	56
4184 N /17 X	$\leq 0,4$	$n < n_G$	2	$\leq 60$	$n > n_G$	0	60	20	$\leq 15$	*	$1500 \pm 100$	60

Subject to alternations

### Note:

With these fan specials, deviations as regards temperature range, voltage range and power consumption are possible compared with standard fans.

### Electrical connection

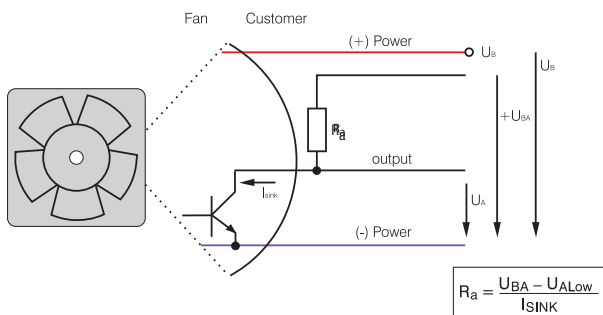

All voltages measured to ground.

External load resistor  $R_a$  from  $U_A$  to  $U_{BA}$  required.

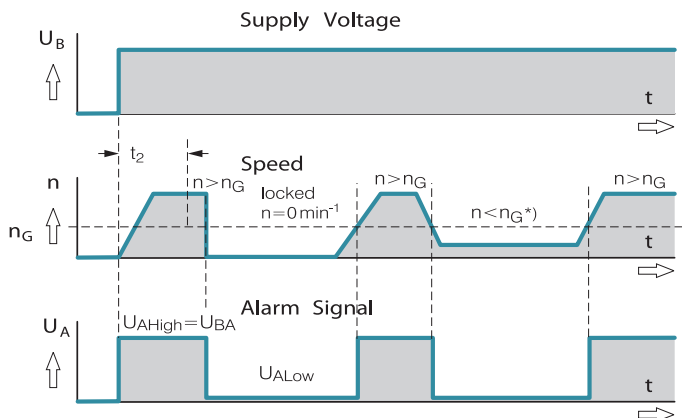

$t_2$  = Alarm signal suppression during start-up

\*  $n <$  speed limit  $n_G$  by braking or locking.

**Available on request:**

- With integrated signal latching for subsequent recognition of short-time faults
  - Alarm circuit open collector or TTL
  - Electrically isolated for maximum device safety
- Defects in the power circuit do not affect the alarm circuit.

Alarm signal data	Alarm output voltage $U_A$ Low	Condition:	Condition: $I_{sink} =$	Alarm output-voltage $U_A$ High	Condition:	Condition: $I_{source}$	Alarm operating-voltage $U_{BA}$ max.	Max. permissible Sink current	Alarm delay time $t_2$	Condition:	Speed limit $n_G$	Fan description Basic type
Type	VDC		mA	VDC		mA	VDC	mA	s		RPM	Page
4312/17 MT VARIOFAN	$\leq 0,4$	$n < n_G$	2	$\leq 60$	$n > n_G$	0	60	20	$\leq 15$	*	$1500 \pm 100$	57
4312/17 T VARIOFAN	$\leq 0,4$	$n < n_G$	2	$\leq 60$	$n > n_G$	0	60	20	$\leq 15$	*	$1500 \pm 100$	57
4314/17 T VARIOFAN	$\leq 0,4$	$n < n_G$	2	$\leq 60$	$n > n_G$	0	60	20	$\leq 15$	*	$1150 \pm 100$	57
4318/17 T VARIOFAN	$\leq 0,4$	$n < n_G$	2	$\leq 60$	$n > n_G$	0	60	20	$\leq 15$	*	$850 \pm 100$	57
7214 N/17	$\leq 0,4$	$n < n_G$	2	$\leq 60$	$n > n_G$	0	60	15	$\leq 15$	*	$1330 \pm 60$	70
Subject to alternations										* After switching on $U_B$		

**Note:**

With these fan specials, deviations as regards temperature range, voltage range and power consumption are possible compared with standard fans.

# Alarm signal /19

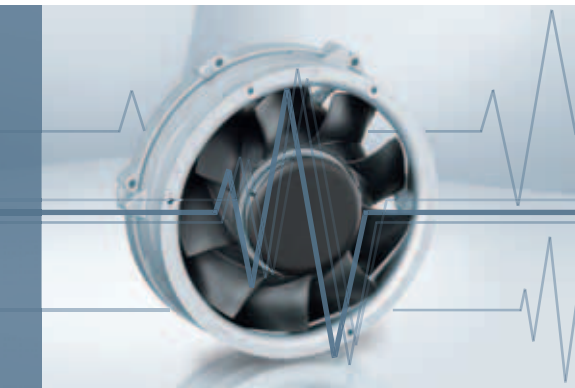

- Alarm signal for speed monitoring
- Signal output via open collector
- The fan emits a low continuous signal during trouble-free operation within the permissible voltage range.
- High signal when speed limit is not reached
- After elimination of fault, the fan returns to its setpoint speed; the alarm signal reverts to low.

Alarm signal data	Alarm output voltage $U_A$ Low	Condition:	Condition: $I_{sink} =$	Alarm output-voltage $U_A$ High	Condition:	Condition: $I_{source}$	Alarm operating-voltage $U_{BA}$ max.	Max. permissible Sink current	Alarm delay time $t_2$	Condition:	Speed limit $n_G$	Fan description Basic type
Type	VDC		mA	VDC		mA	VDC	mA	s		RPM	Page
8314/19 H	$\leq 0,4$	$n > n_G$	2	$\leq 60$	$n < n_G$	0	60	20	$\leq 15$	*	$1500 \pm 100$	46
4312/19	$\leq 0,4$	$n > n_G$	2	$\leq 60$	$n < n_G$	0	60	20	$\leq 15$	*	$1500 \pm 100$	56
7214 N/19	$\leq 0,4$	$n > n_G$	2	$\leq 60$	$n < n_G$	0	60	10	$10 \pm 4$	*	$1800 \pm 20$	70
RLF 100-11/14/19	$\leq 0,4$	$n > n_G$	2	$\leq 28$	$n < n_G$	0	28	10	$10 \pm 4$	*	$1900 \pm 100$	98
RER 101-36/18N/19 HH	$\leq 0,4$	$n > n_G$	2	$\leq 28$	$n < n_G$	0	28	10	$10 \pm 4$	*	$1900 \pm 100$	108

Subject to alternations \* After switching on  $U_B$

### Note:

With these fan specials, deviations as regards temperature range, voltage range and power consumption are possible compared with standard fans.

### Available on request:

- With integrated signal latching for subsequent recognition of short-term faults.
- Alarm circuit open collector or TTL.
- Electrically isolated for max. device safety; defects in power circuit have no effect on the alarm circuit.

### Electrical connection

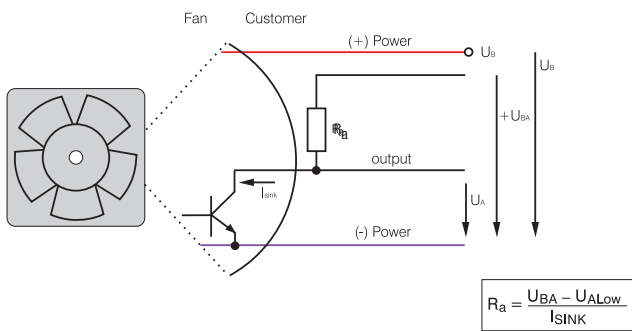

All voltages measured to ground.  
External load resistor  $R_A$  from  $U_A$  to  $U_{BA}$  required.

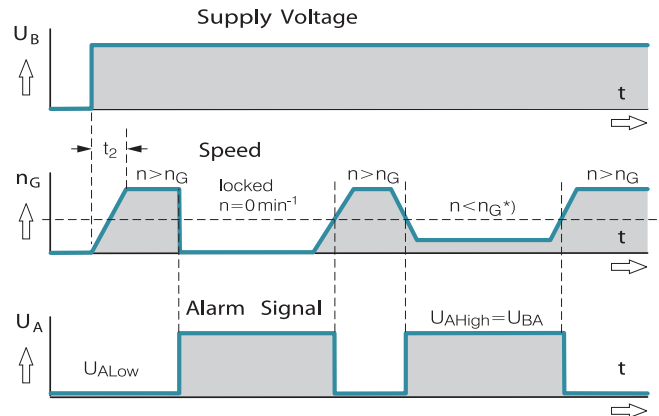

$t_2$  = Alarm signal suppression during start-up.  
\*  $n < n_G$  by braking or locking.

# Alarm signal /37

Go / No-go alarm

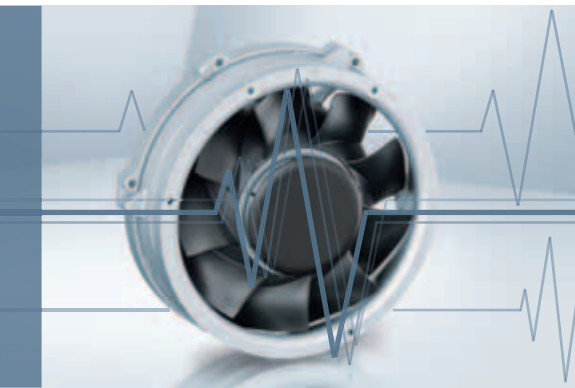

- Alarm signal for speed monitoring
- Signal output via open collector
- The fan emits a high continuous signal during trouble-free operation within the permissible voltage range.
- Low signal when speed limit is not reached
- After elimination of fault, the fan returns to its setpoint speed; the alarm signal reverts to high.

Alarm signal data	Alarm output voltage $U_A$ Low	Condition:	Condition: $I_{sink} =$	Alarm output-voltage $U_A$ High	Condition:	Condition: $I_{source}$	Alarm operating-voltage $U_{BA}$ max.	Max. permissible Sink current	Alarm delay time $t_2$	Condition:	Speed limit $n_G$	Fan description Basic type
Type	VDC		mA	VDC		mA	VDC	mA	s		RPM	Page
8412 N/37 GMLV	$\leq 0,4$	$n \leq n_G$	2	$\leq 28$	$n > n_G$	0	28	10	$< 1$	*	0	45
3412 N/37 GV	$\leq 0,4$	$n \leq n_G$	2	$\leq 28$	$n > n_G$	0	28	10	$< 1$	*	0	49

Subject to alternations \* After switching on  $U_B$

**Note:**

With these fan specials, deviations as regards temperature range, voltage range and power consumption are possible compared with standard fans.

**Available on request:**

- Alarm circuit TTL compatible.

**Electrical connection**

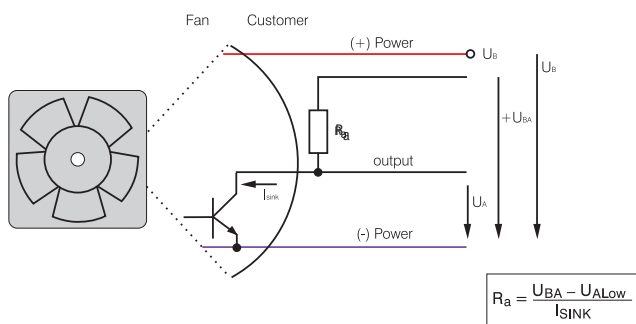

All voltages measured to ground.  
External load resistor  $R_a$  from  $U_A$  to  $U_{BA}$  required.

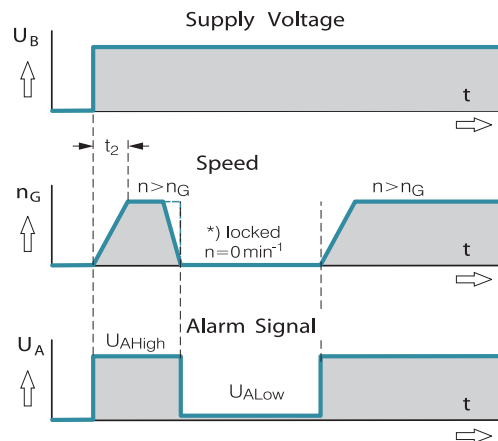

$t_2$  = Alarm signal suppression during start-up.  
\*  $n < n_G$  Speed limit  $n_G$  by braking or locking.

# Alarm signal /39

## Go / No-go alarm

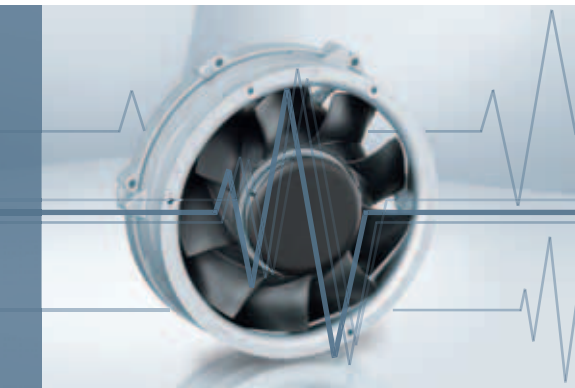

- Alarm signal for speed monitoring
- Signal output via open collector
- The fan emits a low continuous signal during trouble-free operation within the permissible voltage range.
- High signal when speed limit is not reached
- After elimination of fault, the fan returns to its setpoint speed; the alarm signal reverts to low.

Alarm signal data	Alarm output voltage $U_A$ Low	Condition:	Condition: $I_{sink} =$	Alarm output-voltage $U_A$ High	Condition:	Condition: $I_{source}$	Alarm operating-voltage $U_{BA}$ max.	Max. permissible Sink current	Alarm delay time $t_2$	Condition:	Speed limit $n_G$	Fan description Basic type
Type	VDC		mA	VDC		mA	VDC	mA	s		RPM	Page
412/39	≤0,5	$n > n_G$	2	≤28	$n = n_G$	0	28	10	<1	*	0	33
612 F/39 H	≤0,5	$n > n_G$	2	≤28	$n = n_G$	0	28	10	<1	*	0	36
614 N/39 M	≤0,5	$n > n_G$	2	≤28	$n = n_G$	0	28	10	<1	*	0	39
618 N/39 N	≤0,5	$n > n_G$	2	≤28	$n = n_G$	0	28	10	<1	*	0	39
3412 N/39 H	≤0,5	$n > n_G$	2	≤28	$n = n_G$	0	28	10	<1	*	0	48
3414 N/39 HH	≤0,5	$n > n_G$	2	≤28	$n = n_G$	0	28	10	<1	*	0	48
4412 F/39 GL	≤0,5	$n > n_G$	2	≤28	$n = n_G$	0	28	10	<1	*	0	54
4412 F/39 M	≤0,5	$n > n_G$	2	≤28	$n = n_G$	0	28	10	<1	*	0	54
4414 F/39	≤0,5	$n > n_G$	2	≤28	$n = n_G$	0	28	10	<1	*	0	54
4414 FN/39 H	≤0,4	$n > n_G$	2	≤30	$n = n_G$	0	30	4	<1	*	0	55

Subject to alternations

\* After switching on  $U_B$

### Note:

With these fan specials, deviations as regards temperature range, voltage range and power consumption are possible compared with standard fans.

### Electrical connection

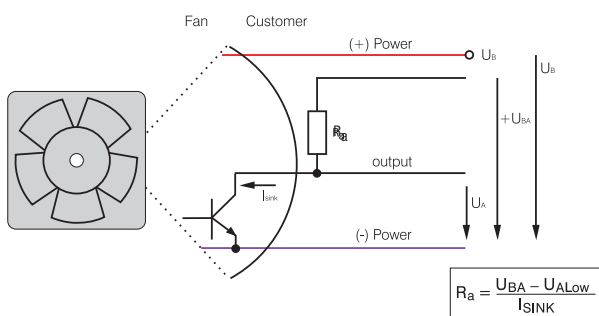

All voltages measured to ground  
External load resistor  $R_a$  from  $U_A$  to  $U_{BA}$  required.

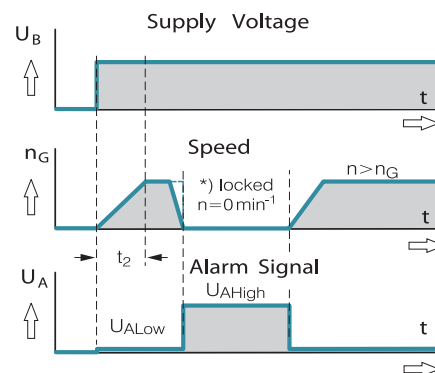

$t_2$  = Alarm signal suppression during start-up  
\*  $n < n_G$  by braking or locking

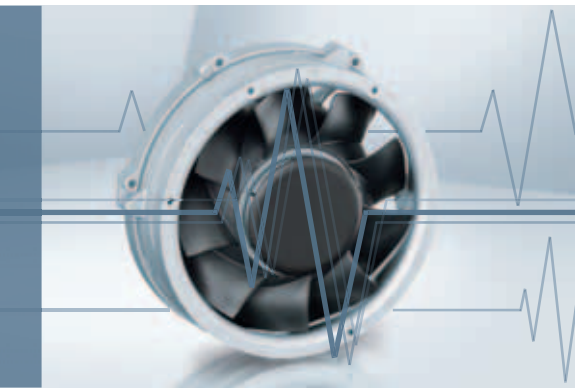

- "Software instead of hardware" – aptly describes the unique fan concept, equipped at the plant with tailor-made intelligence for cooling electronics.
- Flexible configuration using software, allows quicker availability, sampling from the factory and the ability to supply customer-specific solutions in any quantity.

## Vario-Pro-Features

### External Speed setting

- Speed setting via temperature, PWM or analogue control voltage  
See page 174 (Speed setting)
- Description of speed curve with up to 14 selectable interpolation points  
Linear interpolation between the points
- Zero speed possible
- Recognition of sensor failure: In case of loss of sensor, the fan operates at programmable (fail-safe) speed.

### Alarm and tachometer functions

- Optional alarm and/or tachometer function
- Selectable alarm speed limit (with hysteresis) and alarm delay time
- Latching of alarm signal
- Delay only when starting or permanently active
- "High" or "Low" output signal in case of alarm
- Optional alarm if temperature sensor fails
- Optional alarm in case of excess temperature

### Motor management

- High control accuracy due to digital motor management
- Higher operating efficiency due to optimum adaptation of motor hardware and software

Fan series	Page
620	37
8400 N	44
8300	46
8200 J	47
3400 N	48
3300	50
3300 N	51
3200 J	52
3250 J	53
4400 FN	55
4300	56
4100 N	60

Fan series	Page
4100 NH...NH6	61
4100 NH 7-8	62
DV 4100	63
5200 N	64
DV 5200	65
5100 N	66
5300	67
7100 N	69
7200 N	70
6100 N	71
6300	72
DV 6300	75

Fan series	Page
6400	76
DV 6400	78
RL 90 N	97
RLF 100	98
RG 90 N	99
RG 125 N	100
RG 160 N	101
REF 100	107
RER 101	108
RER 125 N	112
RER 160 N	114

# Speed setting via temperature sensor

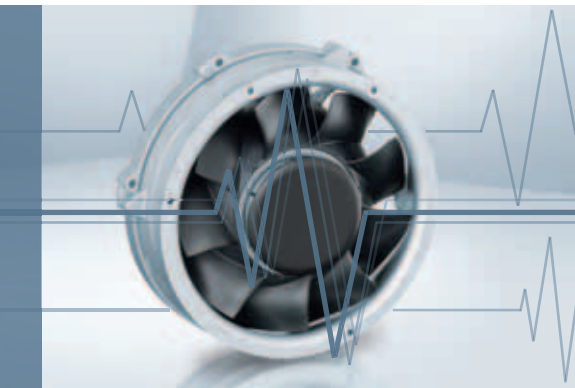

- The control variable is a temperature sensor which is either integrated into the fan or connected to an additional control wire.

## External temperature sensor Type T

- Ext. NTC type LZ370 (p. 253) is required (to be ordered separately)

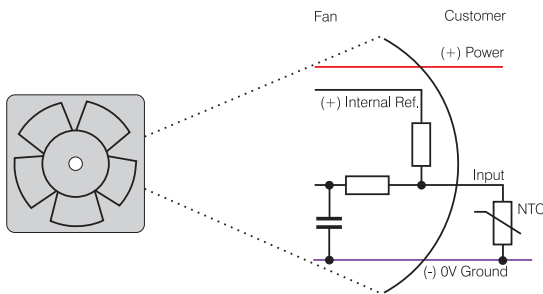

## Internal temperature sensor Type I

- NTC integrated into the fan hub

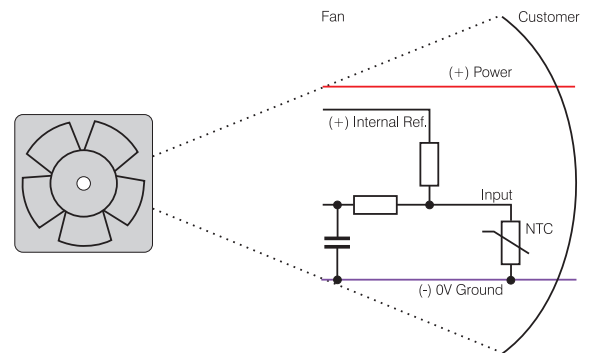

## Standard speed-temperature curve for type T and type I

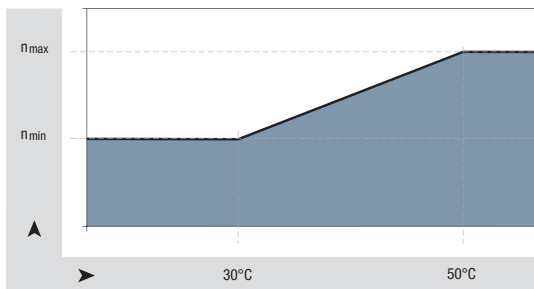

$$n_{\min} \approx \frac{1}{2} n_{\max}$$

$$T_{\min} \approx 30 \text{ }^{\circ}\text{C}; T_{\max} = 50 \text{ }^{\circ}\text{C}$$

## Optionally available with customer specific temperature-speed control curve

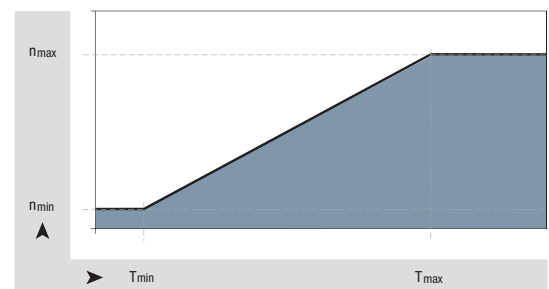

$$n_{\min} \approx 800 \text{ }^1/\text{min} \quad n_{\max} \text{ model-dependent}$$

$$T_{\min} \approx 5 \text{ }^{\circ}\text{C} \quad T_{\max} \leq 85 \text{ }^{\circ}\text{C, model-dependent}$$



# Speed setting with control voltage or PWM

– The control variable is a PWM signal or analogue control voltage.

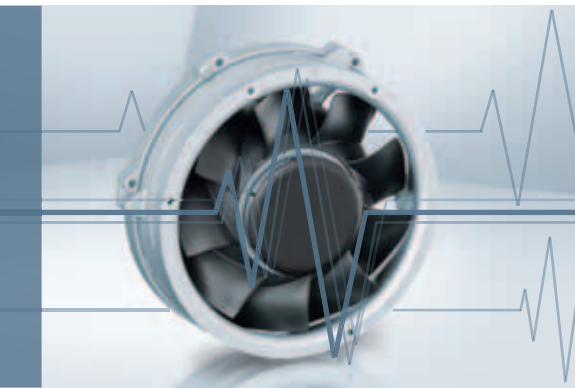

## Speed setting via control voltage Type A

– Standard control range 0 ... 10 V

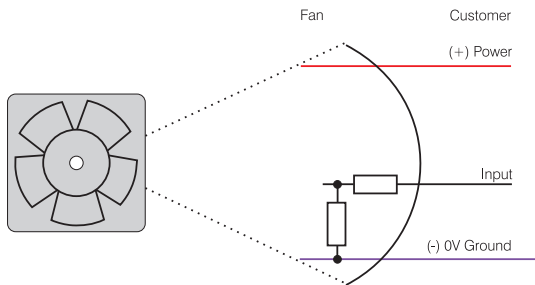

Typical input resistance >10 kΩ

## Drehzahlvorgabe mittels PWM Typ P

- Standard PWM signal in two versions
  - a) PWM frequency, mainly 1– 10 kHz (0–100%), Open collector input
  - b) Four-wire interface in accordance with Intel specifications for 12 VDC fans, PWM frequency 25 kHz, incl. speed signal /2

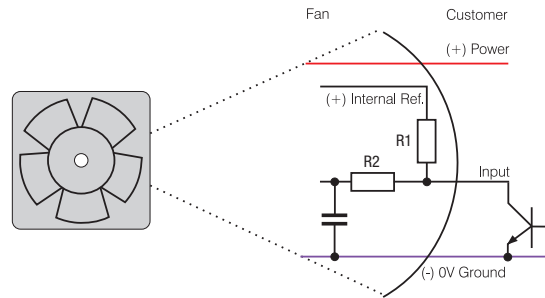

– Optional with potentiometer

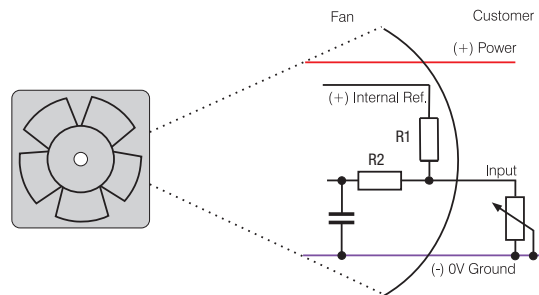

Internal reference = +5V  
 R1 typical 4.7...10 kΩ  
 R2 typical 100 kΩ

## Standard curve P / A

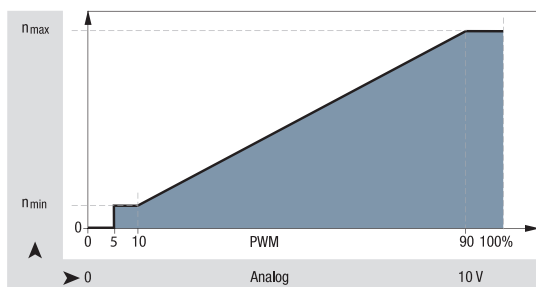

## Optionally available with customer specific P / A speed control curve

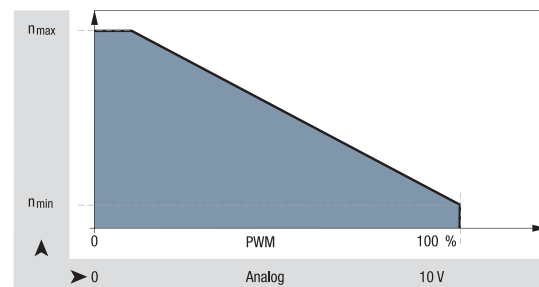

# Speed setting via multi-option control input

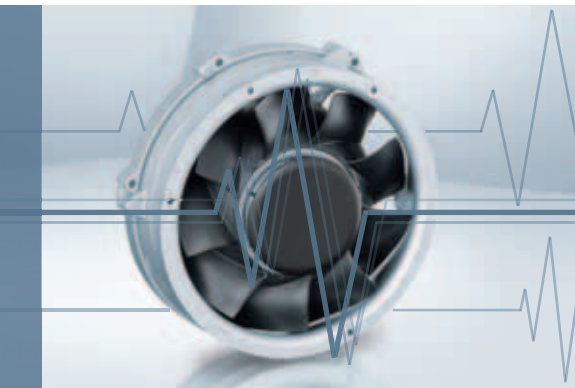

- Customer can operate input either with PWM signal, analogue voltage, external temperature control module or resistor.
- The control signal-speed characteristics of the fan differ from the standard curve of the A and P inputs (see p. 175).
- To attain the maximum speed, the control wire must be switched against UB.
- The control input is usually combined with an open collector tachometer (Type /2, see page 164).

## Speed setting via multi-option control input

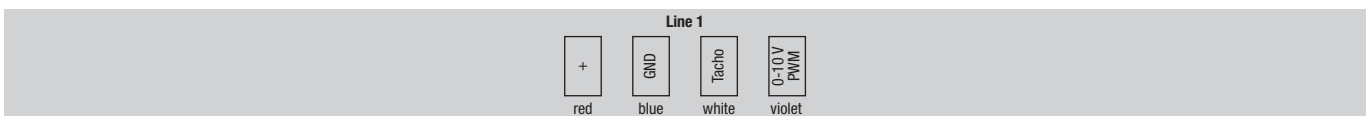
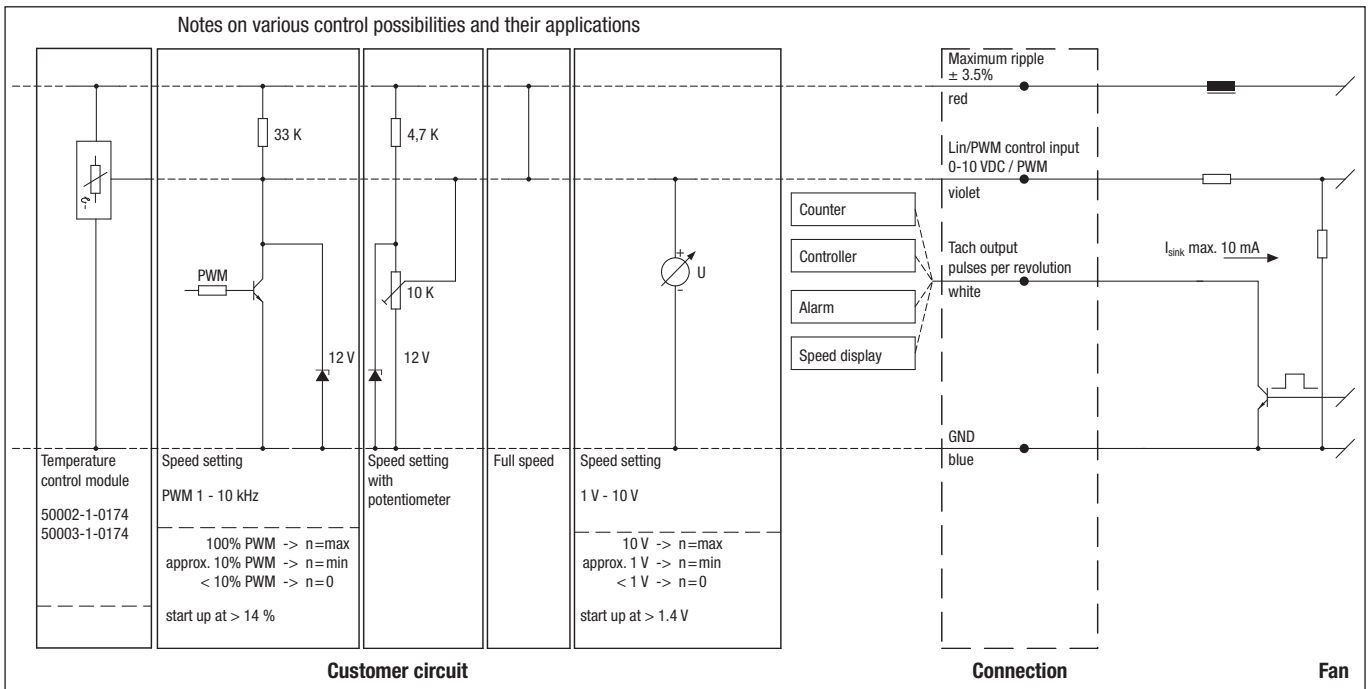

Line	Connection	Colour	Assignment / function
1	+	red	Maximum ripple $\pm 3.5\%$
	GND	blue	GND
	Tach	white	Tach output: 3 pulses / revolution
	0-10 V / PWM	violet	Control input (Impedance 100 k $\Omega$ )

# Protected fans

against environmental influences

- Capable to fulfil special requirements for a broad range of applications
- Resistant to environmental influences, such as dust, splash water, humidity, spray water and salt fog
- Highly competent solutions for adapting fans to environmental conditions



### Moisture protection

Coated motor and printed circuit board protects against humidity and condensation.

### Type of protection: IP 54 / IP 68

In the type of protection IP 54, the motor and circuit boards are coated and therefore protected against spray water and moisture.

The type of protection IP 68 is important for ebm-papst products, as it ensures a high degree of protection for the encapsulated motor and electronic against foreign bodies and water, whilst protecting the user against potential hazards upon contact. Types of protection higher than IP 68 are possible upon request.

The available solutions could be different depending on the fan size. We would be glad to develop solutions tailored to the demands of your application.

### Salt fog protection

Salt fog is extremely demanding on the resistance of the product. ebm-papst makes use of technologies that protect fans and blowers from salt fog reliably and durably.

### Stainless steel bearings

Special bearings made of stainless steel provide additional protection.

### Type of protection – IP code

Protection against foreign bodies and accidental contact (first digit)		Water protection (second digit)	
X	No protection	X	No protection
1	Protection against foreign bodies > 50 mm (back of the hand)	1	Protection against dripping water or condensation
2	Protection against foreign bodies > 12 mm (finger)	2	Protection against dripping water, fans tilted 15° from vertical
3	Protection against foreign bodies > 2,5 mm (tool)	3	Protection against water spray up to 60° from vertical
4	Protection against foreign bodies > 1 mm (wire)	4	Protection against water spray from all sides
5	Protection against dust in harmful quantities	5	Protection against low-pressure water jets
6	Dust-proof	6	Protection against high-pressure water jets
		7	Protection against temporary submersion (15 cm - 1 m)
		8	Protection against continuous submersion



# ACmaxx / GreenTech EC-compact fans



Technical information	180
Overview	183
Axial fans	184

# ACmaxx / GreenTech EC-compact fans

## Technical information



### Progress made by ebm-papst

The best example: The ACmaxx fans from ebm-papst, which, thanks to an ingenious yet simple improvement over conventional AC fans, provide substantial benefits.

The aim in developing the new ACmaxx series was to raise the technology standard of the conventional AC fan significantly and, in the process, facilitate the transition to the new technology by retaining the overall mounting dimensions. In short, to ensure the fans can be replaced 1:1 without any peripheral changes or changes to the voltage situation. ebm-papst offers two generations of ACmaxx products that meet different needs.

### What ACmaxx and GreenTech EC-compact fan have in common: Energy efficiency

The drive concept is based on state-of-the-art GreenTech EC technology with outstanding motor efficiency. Compared to AC fans of the same size, ACmaxx energy consumption is up to 77% lower—for higher cooling capacity! Just the energy savings means that the products pay for themselves after only a few months. The savings over the entire service life, especially in systems with multiple fans, is considerable.

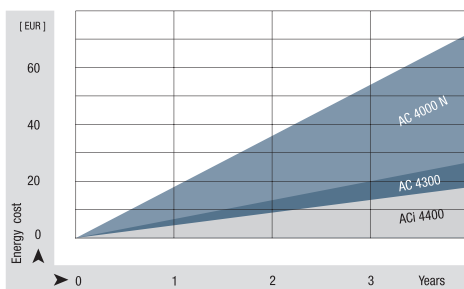

### Independent of mains frequency and mains voltage

The ACmaxx and GreenTech EC-compact fans are prepared for direct connection to all AC voltages and frequencies. The speed, and thus important properties of the fan such as air flow and noise, are independent of the power frequency and do not change, even within the defined voltage range. Voltage fluctuations in the power system are automatically compensated for.

### Long service life

The efficiency of ACmaxx and GreenTech EC-compact fan motors is up to 75% higher than that of conventional AC fan variants. This not only saves energy, it also means less self-heating in the motor. The reduced heating has a direct, positive effect on the bearing system, which is why the fans have a service life that is up to 85% longer! This also extends the service and maintenance intervals significantly. The expense of replacement fans, and even more expensive downtimes, are kept to a manageable minimum.

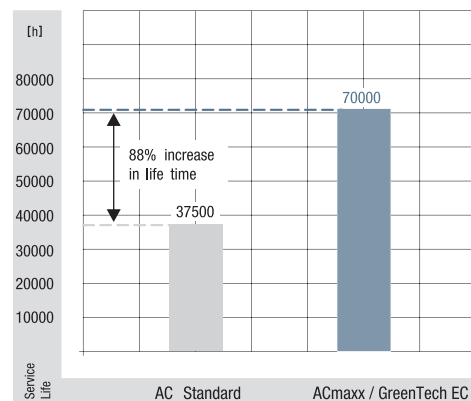

# ACmaxx / GreenTech EC-compact fans

## Technical information



### Safety

- Safety certifications: UL, CSA and VDE 0805 / EN60950. VDE 0700 / EN60335 on request.
- Our fans have the CE mark of conformity.
- EMC protection:
  - > EN61000-4-4 Level 1 (1 kV or 2 kV)B
  - > EN61000-4-2 Level 8 kV/15 kV or 4 kV/8 kV
  - > EN61000-4-3
  - > EN61000-4-6
  - > EN61000-4-8
  - > EN55022 Class B

### Ambient influences

AC fans are extremely common and are used in a wide variety of applications. In control cabinet cooling, beer coolers, cooling cabinets, wood-burning stoves, medical devices – all have different requirements for resistance to ambient influences. ACmaxx and GreenTech EC-compact fans offer the same features for protection against moisture, splash water and rough ambient conditions.

### Particular design features of the GreenTech EC-compact fan (ACi 4400):

#### GreenTech EC-compact fan is more compact!

As large as existing AC fans – and not a bit larger. This is the most outstanding feature of the new GreenTech EC-compact fans ACi 4400. Even in the hub area, the fan does not differ from typical 119 x 119 x 38 mm AC fans. Out with the AC, in with the GreenTech EC-compact fans ACi 4400 – it's that simple.



### GreenTech EC-compact fan is more efficient!

ACmaxx saves energy, and the GreenTech EC-compact fan generation saves even more. While an AC fan at 50 Hz can barely reach an overall efficiency of 5-6%, the ACmaxx makes it to approx. 20-25%. With the new GreenTech EC-compact fans ACi 4400, a remarkable level of up to 30% is reached. This is the result of the optimisation of the entire package made up of drive, electronics, AC/DC conversion and aerodynamics. Thus the new GreenTech EC-compact fans series boasts energy savings of almost 75% compared to the corresponding AC fan, thus providing significantly higher savings than the 40% level of the old AC 4300 generation.

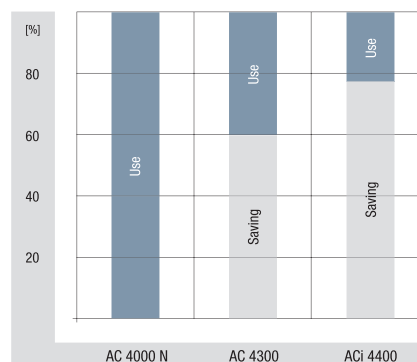

### GreenTech EC-compact fan is quieter!

The GreenTech EC-compact fan ACi 4400 is quieter! Quieter than AC fans and quieter than the existing ACmaxx generation. The reason for this are the optimised aerodynamics and the drive, which is optimised for minimum structure-borne noise. Thus the fan is only half as loud at comparable air performance, and is up to 6 dB(A) quieter at some operating points.

### Speed independent of voltage and frequency

For the GreenTech EC-compact fans ACi 4400, the speed, and thus the air flow and operating noise, are independent of the supply voltage and power frequency.

Versions are available for 115 VAC with a voltage range from 85 to 132 VAC and 230 VAC with a voltage range of 195 to 265 VAC. Voltage fluctuations and frequency differences in the power system are compensated for automatically.



# ACmaxx / GreenTech EC-compact fans

## Technical information



### Particular design features of the ACmaxx:

#### Prepared for all AC voltages

These types have a very wide voltage range from 85 to 265 VAC – the global voltage range, so to speak. This enables the fan to be used around the world, opening up large savings potentials. In addition to reduced logistics effort and stock-keeping, worldwide availability is key. ACmaxx is compatible with every supply voltage—no switching needed. From 85 to 265 volts and mains frequencies of 50 and 60 hertz. Voltage fluctuations in the power system are automatically compensated for.

#### Higher performance

Unlike conventional AC technology, the state-of-the-art drive concept of this fan series is not linked to a fixed power frequency. This allows the motor speed to be increased over a wide range. Thus ACmaxx provides significantly higher air flow and significantly increased pressure.

#### Higher flexibility

The flexibility of ACmaxx is one-of-a-kind. With its intelligent features, ACmaxx can be individually adapted to the specific application: standby mode, overload mode at peak times or night reduction all the way to temperature-controlled quiet operation are all possible. From speed

setting to long-term function checks using an alarm or speed signal outputs, ACmaxx offers optional interfaces that allow you to monitor operation quickly and easily.

You can find further information about these fan options in the "Specialised fans" chapter, starting on page 161.

Or you can simply contact our application engineers to discuss your ideal ACmaxx or GreenTech EC-compact fan.

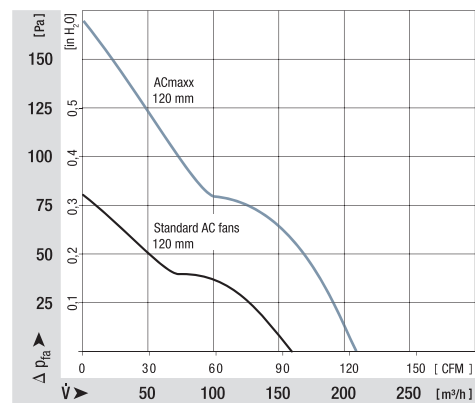

# Fans for AC operation

## Overview of air performance

Dimension mm	Series	Air flow m <sup>3</sup> /h	Air flow scale																Page	
			10	20	30	40	50	60	70	80	90	100	200	300	400	500	600	700		800
□ 80 x 32	AC 8300 H	80	[Performance bar]																184	
□ 92 x 38	AC 3200 J	144	[Performance bar]																185	
□ 119 x 25	AC 4400 FN	205	[Performance bar]																186	
□ 119 x 32	AC 4300	204	[Performance bar]																187	
□ 119 x 38	ACi 4400 100...175	175	[Performance bar]																188	
∅ 130	W1G 130 220...370	370	[Performance bar]																190	
∅ 172 x 51	AC 6100 N	350	[Performance bar]																192	
∅ 172 x 51	AC 6200 N	350	[Performance bar]																193	
∅ 200	W3G 200 560...1000	1000	[Performance bar]																194	
∅ 250	W3G 250 900...1700	1700	[Performance bar]																196	
∅ 98,5 x 130	AC 100 NR 80...105	105	[Performance bar]																198	

Subject to alternations

## Overview of technically feasible designs

Dimension		VDE, UL, CSA	Sinter sleeve bearings / ball bearings	Speed signal	Go / No-go alarm	Alarm with limit speed	External temperature sensor	Internal temperature sensor	PWM control input	Analogue control input	Multi-option control input	Humidity protection	IP >= IP 54	IP >= IP 68	Salt fog protection	Page
<b>ACmaxx / ACi Axial fans</b>																
Series	mm						OPTIONAL								p.	
AC 8300 H	80 x 80 x 32	*	■	•	•	•	•	•	•	•	–	•	•	–	•	184
AC 3200 J	92 x 92 x 38	*	■	•	•	•	•	•	•	•	–	•	•	–	•	185
AC 4400 FN	119 x 119 x 25	*	■	•	•	•	•	•	•	•	–	•	–	–	–	186
AC 4300	119 x 119 x 32	*	■	•	•	•	•	•	•	•	–	•	•	•	•	187
ACi 4400	119 x 119 x 38	*	■	–	–	–	–	–	–	–	–	•	•	–	•	188
AC 6100 N	∅ 172 x 51	*	■	•	•	•	•	•	•	•	–	•	–	–	–	192
AC 6200 N	∅ 172 x 51	*	■	•	•	•	•	•	•	•	–	•	•	–	•	193
AC 100 NR	∅ 100 x 130	*	■	–	–	–	–	–	–	–	–	•	•	–	–	198

Subject to alternations

- not yet available
  - available
  - Sleeve bearings
  - Ball bearings
- \* Partially granted, partially in registration stage.

Please note that these special versions are not possible for all voltages and speeds, and not in all combinations. The special versions are designed for specific customers and projects. As a rule they are not available off the shelf and are tied to minimum volumes. Please consult your customer support representative about the feasibility of your special variant.

max. 80 m<sup>3</sup>/h

# ACmaxx axial fans

Series AC 8300 H 80 x 80 x 32 mm



- **Material:** Housing: GRP<sup>1)</sup> (PBTP)  
Impeller: GRP<sup>1)</sup> (PA)
  - **Direction of air flow:** Exhaust over struts
  - **Direction of rotation:** Clockwise, seen on rotor
  - **Connection:** Via single wires AWG 22, TR 64
  - **Highlights:** Universally usable for all mains voltages between 85 and 265 VAC
  - **Mass:** 325 g
- **Possible special versions:** (See chapter DC fans - specials)
    - Speed signal
    - Go / No-go alarm
    - Alarm with limit speed
    - External temperature sensor
    - Internal temperature sensor
    - PWM control input
    - Analogue control input
    - Protection against moisture
    - Protection against salt fog
    - Type of protection: IP 54

1) Fibreglass-reinforced plastic

Nominal data	Air flow	Air flow	Nominal voltage	Frequency	Voltage range	Sound pressure level	Sound power level	Sinter sleeve bearings Ball bearings	Input power	Nominal speed	Temperature range	Service life L <sub>10</sub> at 40 °C	at T <sub>max</sub>	Curve
Type	m <sup>3</sup> /h	CFM	V	Hz	VAC	dB(A)	Bel(A)	□ / ■	Watts	rpm	°C	Hours	Hours	
AC 8300 H	80	47	115 / 230	50 / 60	85 ... 265	48	6,2	□ / ■	8,3	5 000	-20...+75	55 000 / 25 000		①

Subject to alternations

Speed variants available on request.

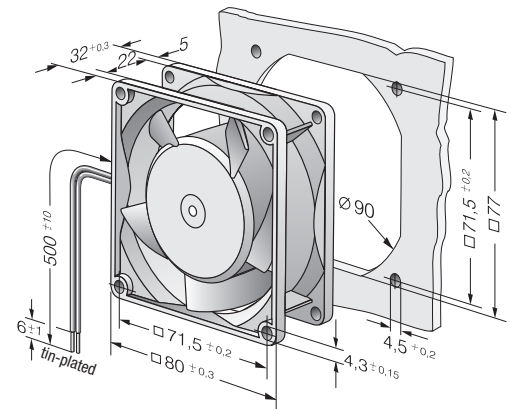
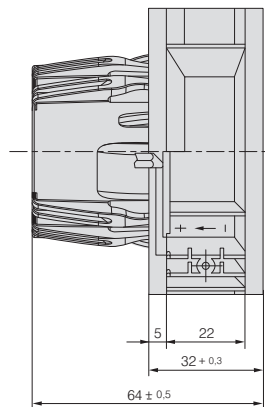
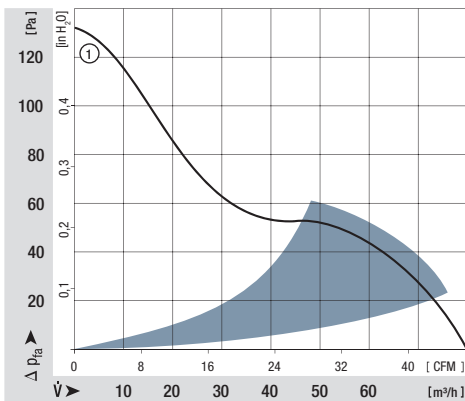

max. 144 m<sup>3</sup>/h

# ACmaxx axial fans

Series AC 3200 J 92 x 92 x 38 mm



- **Material:** Housing: GRP<sup>1)</sup> (PBTP)  
Impeller: GRP<sup>1)</sup> (PA)
  - **Direction of air flow:** Exhaust over struts
  - **Direction of rotation:** Clockwise, seen on rotor
  - **Connection:** Via single wires AWG 22, TR 64
  - **Highlights:** Universally usable for all mains voltages between 85 and 265 VAC
  - **Mass:** 325 g
- **Possible special versions:** (See chapter DC fans - specials)
    - Speed signal
    - Go / No-go alarm
    - Alarm with limit speed
    - External temperature sensor
    - Internal temperature sensor
    - PWM control input
    - Analogue control input
    - Protection against moisture
    - Protection against salt fog
    - Type of protection: IP 54

1) Fibreglass-reinforced plastic

Nominal data	Air flow		Nominal voltage	Frequency	Voltage range	Sound pressure level	Sound power level	Sinter sleeve bearings Ball bearings	Input power	Nominal speed	Temperature range	Service life L <sub>10</sub> at 40 °C	at T <sub>max</sub>
	m <sup>3</sup> /h	CFM											
AC 3200 JH	144	85	115 / 230	50 / 60	85 ... 265	55	6,4	/ ■	12	6 800	-20...+70	70 000 / 35 000	①

Subject to alternations

Speed variants available on request.

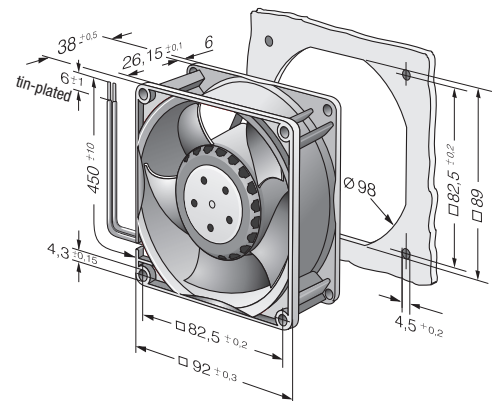
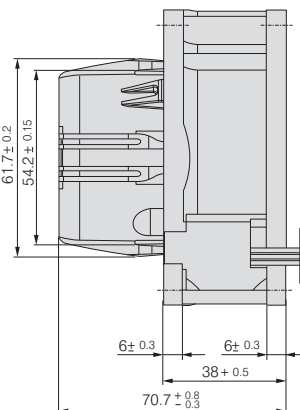
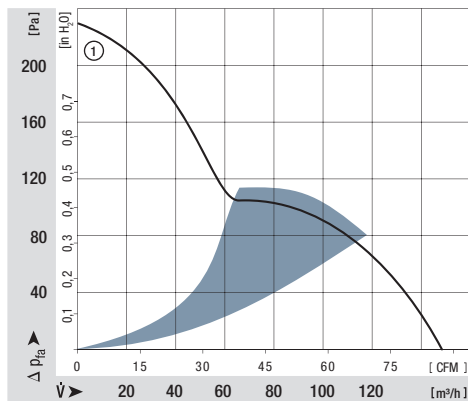

max. 205 m<sup>3</sup>/h

# ACmaxx axial fans

Series AC 4400 FN 119 x 119 x 25 mm



- **Material:** Housing: GRP<sup>1)</sup> (PBTP)  
Impeller: GRP<sup>1)</sup> (PA)
  - **Direction of air flow:** Exhaust over struts
  - **Direction of rotation:** Counter-clockwise, seen on rotor
  - **Connection:** Via single wires AWG 22, TR 64
  - **Highlights:** Universally usable for all mains voltages between 85 and 265 VAC
  - **Mass:** 370 g
- **Possible special versions:** (See chapter DC fans - specials)
    - Speed signal
    - Go / No-go alarm
    - Alarm with limit speed
    - External temperature sensor
    - Internal temperature sensor
    - PWM control input
    - Analogue control input
    - Protection against moisture

1) Fibreglass-reinforced plastic

Nominal data	Air flow	Air flow	Nominal voltage	Frequency	Voltage range	Sound pressure level	Sound power level	Sintec sleeve bearings Ball bearings	Input power	Nominal speed	Temperature range	Service life L <sub>10</sub> at 40 °C	at T <sub>max</sub>
Type	m <sup>3</sup> /h	CFM	V	Hz	VAC	dB(A)	Bel(A)	□ / ■	Watts	rpm	°C	Hours	Hours
AC 4400 FNN	205	121	115 / 230	50 / 60	85 ... 265	53	6,2	□ / ■	12	4 850	-20...+70	60 000 / 30 000	①

Subject to alternations

Speed variants available on request.

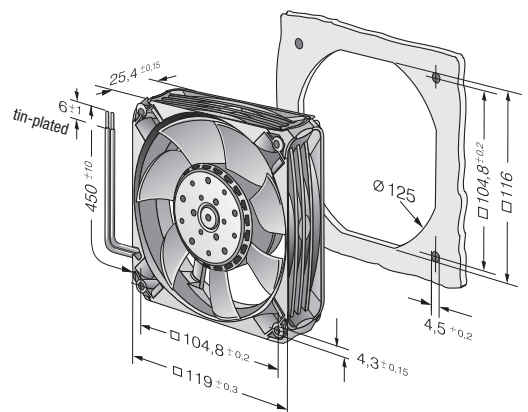
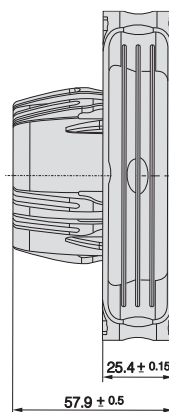
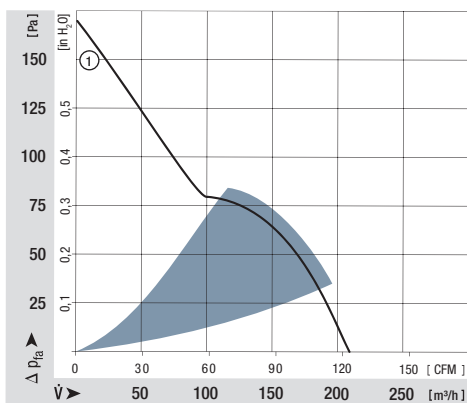

max. 204 m<sup>3</sup>/h

# ACmaxx axial fans

Series AC 4300 119 x 119 x 32 mm



- **Material:** Housing: GRP<sup>1)</sup> (PBTP)  
Impeller: GRP<sup>1)</sup> (PA)
  - **Direction of air flow:** Exhaust over struts
  - **Direction of rotation:** Clockwise, seen on rotor
  - **Connection:** Via single wires AWG 22, TR 64
  - **Highlights:** Universally usable for all mains voltages between 85 and 265 VAC
  - **Mass:** 325 g
- **Possible special versions:**  
(See chapter DC fans - specials)
    - Speed signal
    - Go / No-go alarm
    - Alarm with limit speed
    - External temperature sensor
    - Internal temperature sensor
    - PWM control input
    - Analogue control input
    - Protection against moisture
    - Protection against salt fog
    - Type of protection: IP 54 / IP 68

1) Fibreglass-reinforced plastic

Nominal data		Air flow	Air flow	Nominal voltage	Frequency	Voltage range	Sound pressure level	Sound power level	Sinter sleeve bearings Ball bearings	Input power	Nominal speed	Temperature range	Service life L <sub>10</sub> at 40 °C	at T <sub>max</sub>	Kemlinie
Type		m <sup>3</sup> /h	CFM	V	Hz	VAC	dB(A)	Bel(A)	□ / ■	Watts	rpm	°C	Hours	Hours	
AC 4300 H		204	120	115 / 230	50 / 60	85 ... 265	51	6,4	□ / ■	12	3 400	-20...+70	45 000 / 22 500		①

Subject to alternations

Speed variants available on request.

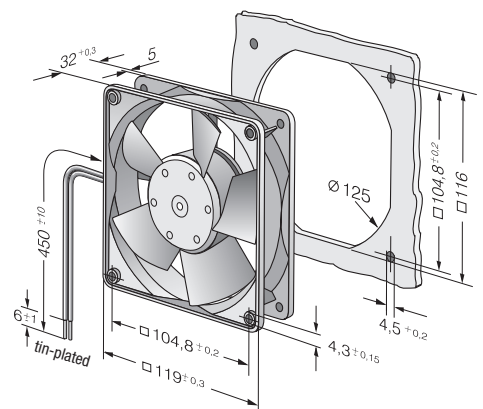
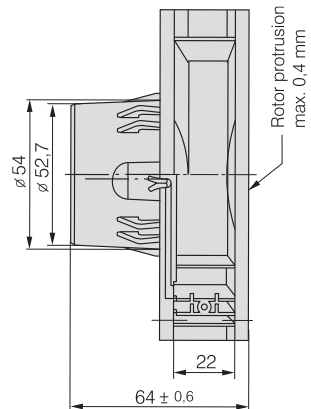
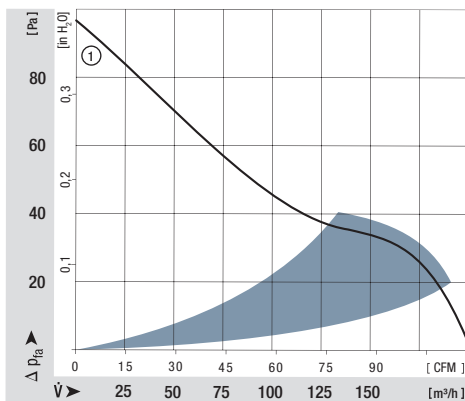



max. 175 m<sup>3</sup>/h

# GreenTech EC-Compact fan axial fans

Series ACi 4400 119 x 119 x 38 mm



- **Material:** Housing: GRP<sup>1)</sup> (PBT)  
Impeller: GRP<sup>1)</sup> (PA)
  - **Direction of air flow:** Exhaust over struts
  - **Direction of rotation:** Clockwise, seen on rotor
  - **Connection:** via 2 flat plugs 2,8 x 0,5 mm  
flying leads optional
  - **Highlights:** Fully integrated converter and fan electronics
  - **Mass:** 250 g
- **Possible special versions:**  
(See chapter DC fans - specials)
    - Protection against moisture
    - Protection against salt fog
    - Type of protection: IP 54

1) Fibreglass-reinforced plastic

Nominal data	Air flow		Nominal voltage	Voltage range	Sound pressure level	Sound power level	Sinter sleeve bearings Ball bearings	Input power	Nominal speed	Temperature range	Service life L <sub>10</sub> (40 °C) ebm-papst Standard	Service life L <sub>10</sub> (T <sub>max</sub> ) ebm-papst Standard	Life expectancy L <sub>10</sub> IPPC (40 °C) see page 17	Curve
	m <sup>3</sup> /h	CFM												
ACi 4420 ML	100	59	230	195...265	25	4,1	■	1,4	1 850	-20...+75	65 000 / 25 000	110 000	110 000	①
ACi 4420 N	147	86	230	195...265	36	4,9	■	2,8	2 700	-20...+75	65 000 / 25 000	110 000	110 000	②
ACi 4420 H	160	94	230	195...265	39	5,1	■	3,3	3 000	-20...+75	65 000 / 25 000	110 000	110 000	③
ACi 4420 HH	175	106	230	195...265	42	5,3	■	4,4	3 300	-20...+75	65 000 / 25 000	110 000	110 000	④
ACi 4410 HH	175	106	115	85...132	42	5,3	■	4,4	3 300	-20...+75	65 000 / 25 000	110 000	110 000	④

Subject to alternations

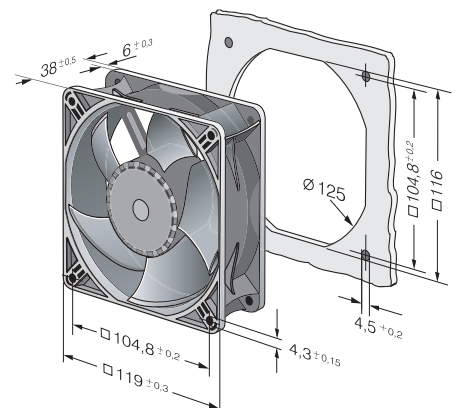
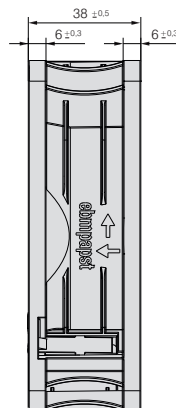
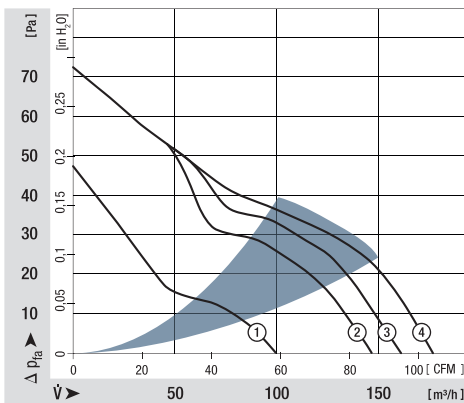





max. 370 m<sup>3</sup>/h

# Energy-saving axial fans

Ø 130 mm



- **Material:** Wall ring: Plastic PP, fibreglass-reinforced  
Blades: Plastic PA, fibreglass-reinforced
- **Number of blades:** 7
- **Direction of air flow:** "V", exhaust over struts
- **Direction of rotation:** Counter-clockwise, seen on rotor
- **Type of protection:** IP 54
- **Insulation class:** "B"
- **Mounting position:** Any
- **Condensate discharges:** None
- **Operation mode:** Continuous operation (S1)
- **Bearings:** Maintenance-free ball bearings

Nominal data		Curve	Nominal voltage	Frequency	Speed / rpm <sup>(1)</sup>	Max. input power <sup>(1)</sup>	Max. current draw <sup>(1)</sup>	Max. back-pressure	Perm. amb. temp.	Mass	Electrical connections
Type	Motor	VAC	Hz	rpm	W	A	Pa	°C	kg		
<b>W1G130-AA49 -01</b>	M1G055-AI	Ⓐ 1~115	50/60	3200	24	0,38	90	-30..+60	0,75	p. 259 / J7)	
<b>W1G130-AA25 -01</b>	M1G055-AI	Ⓑ 1~230	50/60	3200	24	0,19	90	-30..+70	0,75	p. 259 / J7)	

Subject to alternations

<sup>(1)</sup> Nominal data in operating point with maximum load and 115 or 230 VAC

Curve:

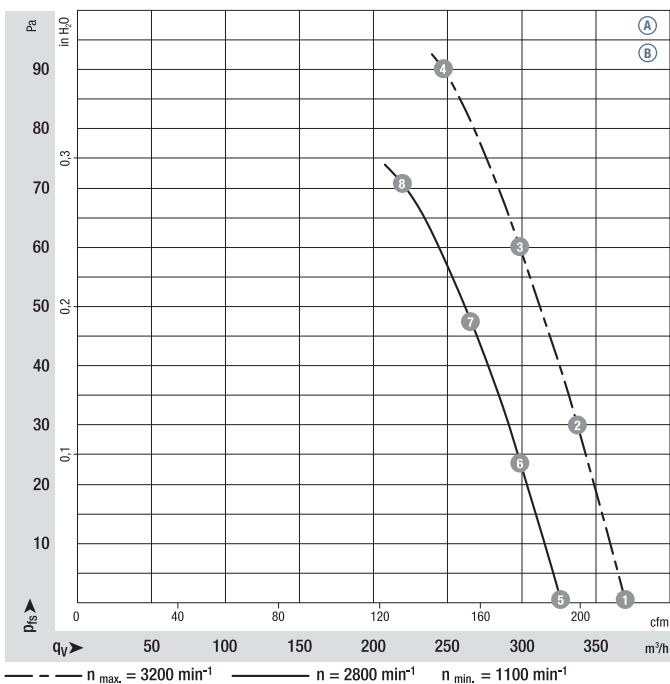

Air performance measured as per: ISO 5801, Installation category A, with ebm-papst inlet nozzle without protection against accidental contact. Suction-side noise levels: L<sub>WA</sub> as per ISO 13347, L<sub>pA</sub> measured at 1 m distance to fan axis. The acoustic values given are only valid under the measurement conditions listed and may vary depending on the installation situation. With any deviation to the standard setup, the specific values have to be checked and reviewed once installed or fitted! For detailed information see [http://www.ebmpapst.com/general\\_conditions](http://www.ebmpapst.com/general_conditions)

	n rpm	P <sub>ed</sub> W	I A	L <sub>WA</sub> dB(A)
Ⓐ 1	3200	23	0,38	63
Ⓐ 2	3200	24	0,38	61
Ⓐ 3	3200	24	0,38	60
Ⓐ 4	3200	24	0,38	63
Ⓐ 5	2800	16	0,26	60
Ⓐ 6	2800	16	0,26	58
Ⓐ 7	2800	16	0,26	57
Ⓐ 8	2800	16	0,26	60
Ⓑ 1	3200	23	0,19	63
Ⓑ 2	3200	24	0,19	61
Ⓑ 3	3200	24	0,19	60
Ⓑ 4	3200	24	0,19	63
Ⓑ 5	2800	16	0,13	60
Ⓑ 6	2800	16	0,13	58
Ⓑ 7	2800	16	0,13	57
Ⓑ 8	2800	16	0,13	60

- **Motor protection:** Via electronics and TOP
- **Electrical connection:** Plug-in connection on motor side
- **Protection class:** II
- **Product conforming to standards:** CE; EN 60335-1
- **Approvals:** VDE, UL, CSA, GOST are applied for
- **Speed:** Using the programming unit 2 speeds between  $n_{min}$  and  $n_{max}$  can be programmed

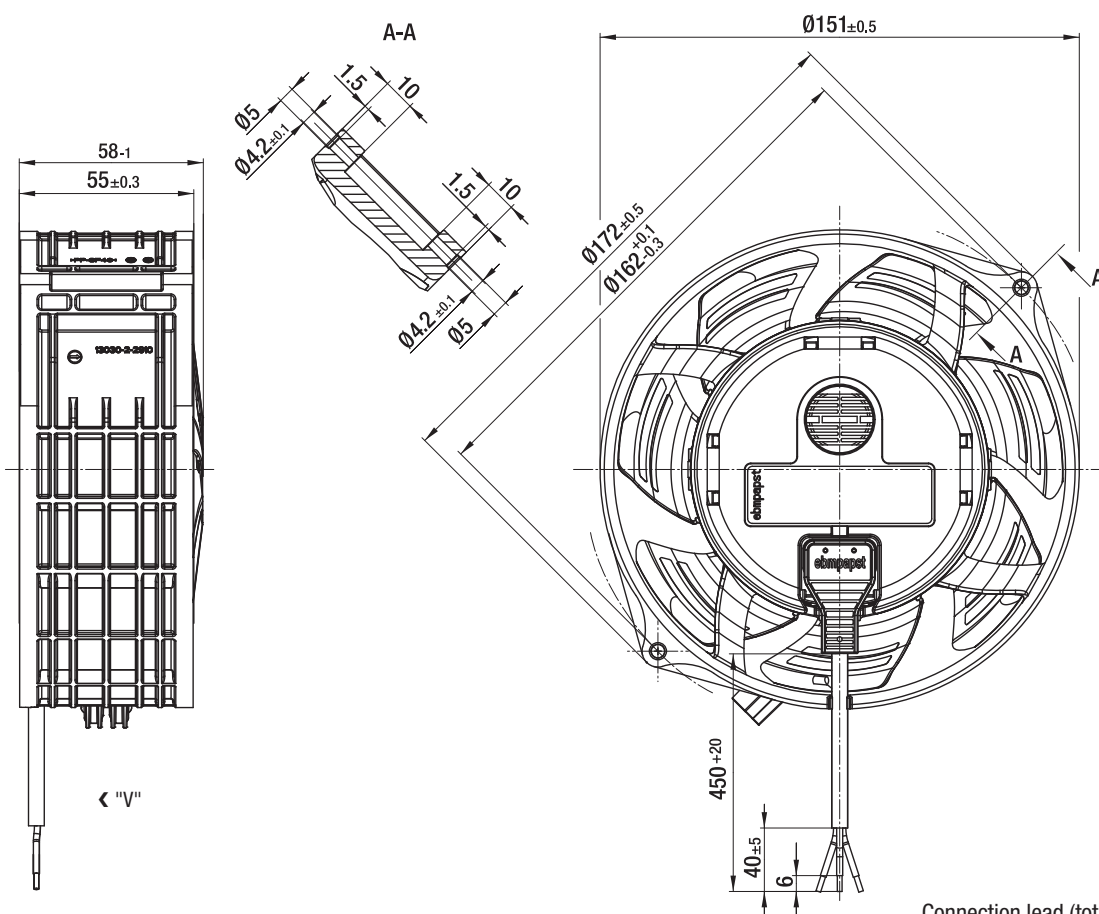

Connection lead (total length 450 mm) is fitted ex works and can be detached.

max. 350 m<sup>3</sup>/h

# ACmaxx axial fans

Series AC 6100 N 172 x 160 x 51 mm



- **Material:** Housing: GRP<sup>1)</sup> (PA)  
Impeller: GRP<sup>1)</sup> (PA)
  - **Direction of air flow:** Exhaust over struts
  - **Direction of rotation:** Counter clockwise, seen on rotor
  - **Connection:** Via single wires AWG 22, TR 64
  - **Highlights:** Universally usable for all mains voltages between 85 and 265 VAC, 50-60 Hz
  - **Mass:** 760 g
- **Possible special versions:** (See chapter DC fans - specials)
    - Speed signal
    - Go / No-go alarm
    - Alarm with limit speed
    - External temperature sensor
    - Internal temperature sensor
    - PWM control input
    - Analogue control input
    - Protection against moisture

1) Fibreglass-reinforced plastic

Nominal data	Air flow		Nominal voltage	Frequency	Voltage range	Sound pressure level	Sound power level	Sinter sleeve bearings Ball bearings	Input power	Nominal speed	Temperature range	Service life L <sub>10</sub> at 40 °C	at T <sub>max</sub>	Curve
	m <sup>3</sup> /h	CFM												
AC 6100 NM	350	206	115 / 230	50 / 60	85 ... 265	52	6,1	/■	14	2 850	-20...+70	80 000 / 37 500		①

Subject to alternations

Speed variants available on request.

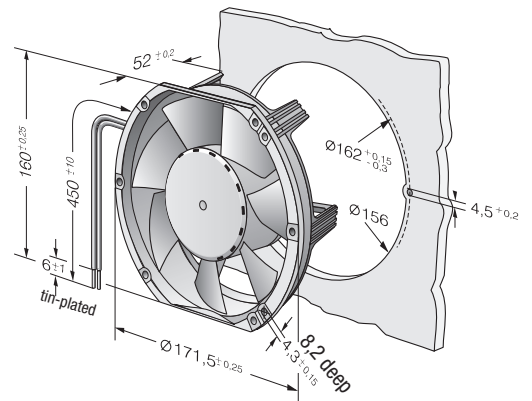
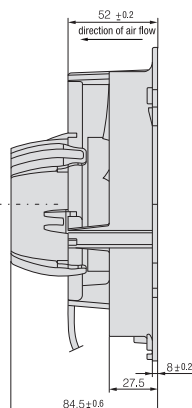
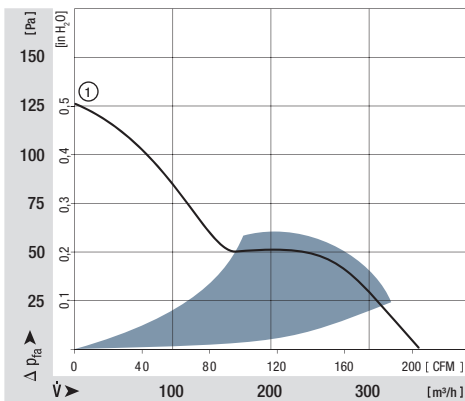

max. 350 m<sup>3</sup>/h

# ACmaxx axial fans

Series AC 6200 N Ø 172 x 51 mm



- **Material:** Housing: Die-cast aluminium  
Impeller: GRP<sup>1)</sup> (PA)
- **Direction of air flow:** Exhaust over struts
- **Direction of rotation:** Counter clockwise, seen on rotor
- **Connection:** Via single wires AWG 22, TR 64
- **Highlights:** Universally usable for all mains voltages between 85 and 265 VAC, 50-60 Hz  
Housing with grounding lug for screw M4 x 8 (Torx)
- **Mass:** 900 g

- **Possible special versions:** (See chapter DC fans - specials)
  - Speed signal
  - Go / No-go alarm
  - Alarm with limit speed
  - External temperature sensor
  - Internal temperature sensor
  - PWM control input
  - Analogue control input
  - Protection against moisture
  - Protection against salt fog
  - Type of protection: IP 54

1) Fibreglass-reinforced plastic

Nominal data	Air flow	Air flow	Nominal voltage	Frequency	Voltage range	Sound pressure level	Sound power level	Sintec sleeve bearings Ball bearings	Input power	Nominal speed	Temperature range	Service life L <sub>10</sub> at 40 °C	at T <sub>max</sub>	Curve
Type	m <sup>3</sup> /h	CFM	V	Hz	VAC	dB(A)	Bel(A)	□ / ■	Watts	rpm	°C	Hours	Hours	
AC 6200 NM	350	206	115 / 230	50 / 60	85 ... 265	50	5,7	□ / ■	14	2 850	-20...+70	80 000 / 40 000		①

Subject to alternations

Speed variants available on request.

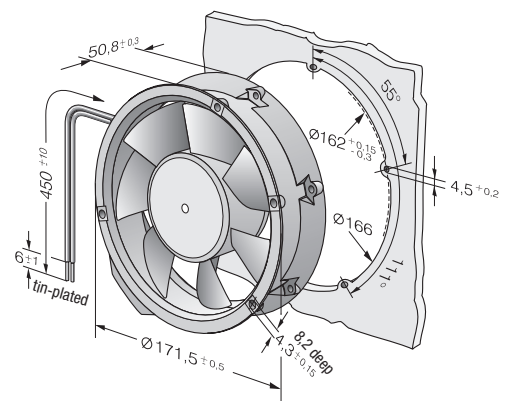
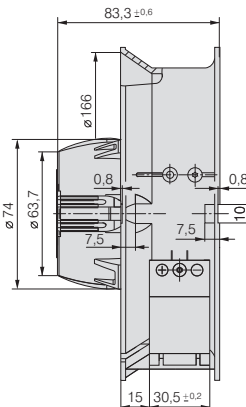
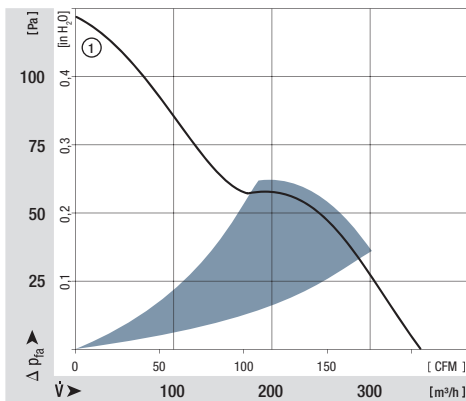

max. 1000 m<sup>3</sup>/h

# EC axial fans

Ø 200 mm



- **Material:** Wall ring: Die-cast aluminium  
Blades: Plastic PP  
Rotor: Thick layer passivated
- **Number of blades:** 7
- **Direction of air flow:** "V", exhaust over struts
- **Direction of rotation:** Counter-clockwise, seen on rotor
- **Type of protection:** IP 54
- **Insulation class:** "B"
- **Mounting position:** Any
- **Condensate discharges:** None, open rotor
- **Operation mode:** Continuous operation (S1)
- **Bearings:** Maintenance-free ball bearings

Nominal data		Curve	Nominal voltage	Frequency	Speed / rpm <sup>(1)</sup>	Max. input power <sup>(1)</sup>	Max. current draw <sup>(1)</sup>	Max. back-pressure	Perm. amb. temp.	Mass	Technical features and electrical connection
Type	Motor	VAC	Hz	rpm	W	A	Pa	°C	kg		
<b>W3G200-HD01 -01</b>	M3G055-BD	Ⓐ 1~230	50/60	2900	54	0,55	96	-25..+60	1,6	p. 256 / H3)	
<b>W3G200-HD01 -03</b>	M3G055-BD	Ⓑ 1~230	50/60	2900	54	0,55	96	-25..+60	1,7	p. 257 / H4)	

Subject to alternations

<sup>(1)</sup> Nominal data in operating point with maximum load and 230 VAC

Curve:

- Ⓐ 2 Speed stages
- Ⓑ Speed-controlled

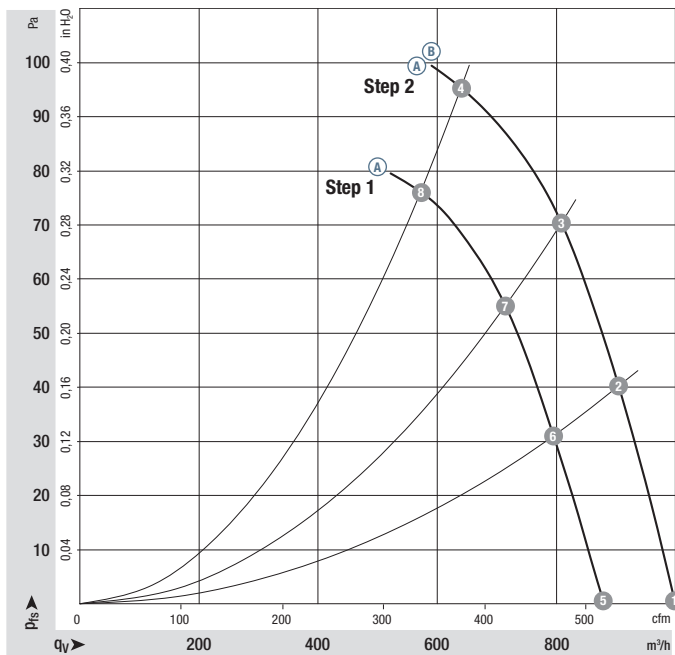

	n rpm	P <sub>ed</sub> W	I A	L <sub>WA</sub> dB(A)
Ⓐ 1	2970	50	0,49	65
Ⓐ 2	2890	54	0,53	64
Ⓐ 3	2830	58	0,56	65
Ⓐ 4	2900	54	0,55	70
Ⓐ 5	2645	36	0,37	62
Ⓐ 6	2575	39	0,40	61
Ⓐ 7	2530	42	0,42	62
Ⓐ 8	2500	43	0,43	67
Ⓑ 1	2970	50	0,49	65
Ⓑ 2	2890	54	0,53	64
Ⓑ 3	2830	58	0,56	65
Ⓑ 4	2900	54	0,55	70

Air performance measured as per: ISO 5801, Installation category A, without protection against accidental contact. Suction-side noise levels: LWA as per ISO 13347, LpA measured at 1 m distance to fan axis. The acoustic values given are only valid under the measurement conditions listed and may vary depending on the installation situation. With any deviation to the standard setup, the specific values have to be checked and reviewed once installed or fitted! For detailed information see <http://www.ebmpapst.com/general conditions>



- **Technical features:** See electrical connections p. 256/257
- **EMC:** Interference immunity acc. to EN 61000-6-2 (industrial environment)  
Harmonics acc. to EN 61000-3-2/3  
Interference emission acc. to EN 55022 (class B, household environment)  
On account of the installation conditions, ferritic damping in the connection line may be required for the application.
- **Touch current:**  $\leq 3.5$  mA acc. to IEC 60990 (test circuit, illustration 4)
- **Electrical connection:** Via terminal strip
- **Protection class:** I (if customer has provided connection for protective earth)
- **Product conforming to standards:** EN 60335-1, CE
- **Approvals:** cURus

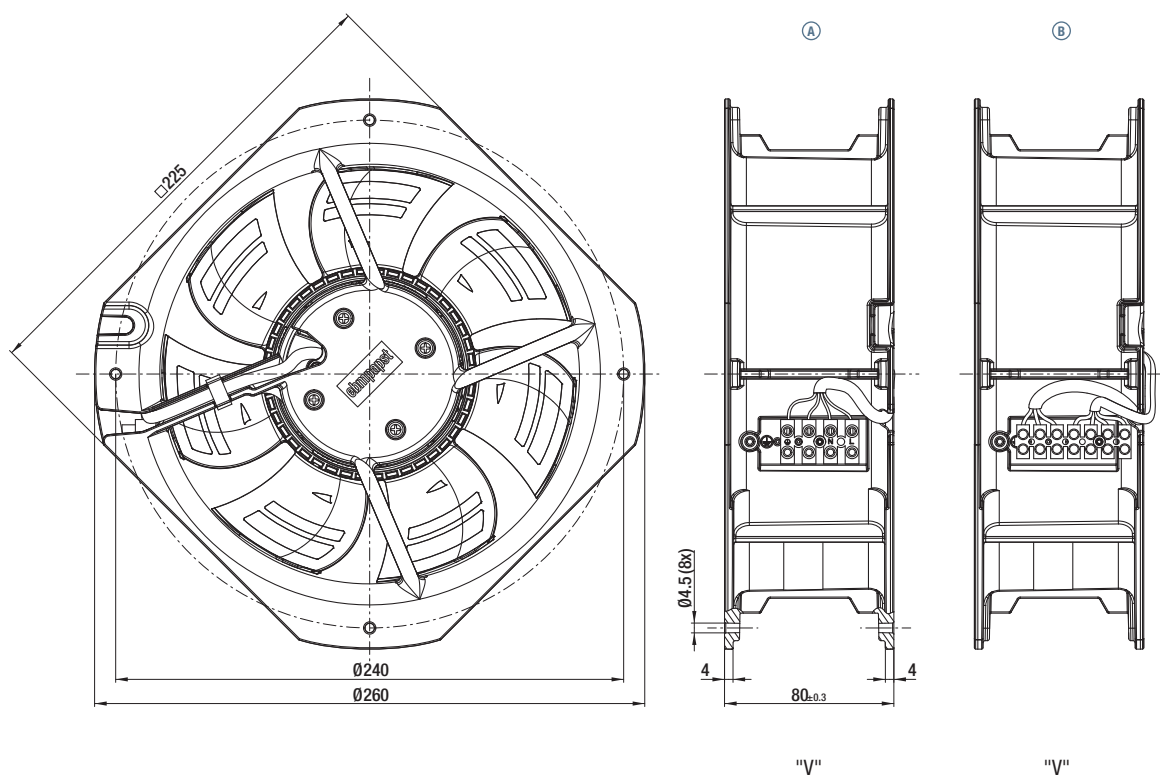



max. 1700 m<sup>3</sup>/h

# EC axial fans

Ø 250 mm



- **Material:** Wall ring: Die-cast aluminium  
Blades: Plastic PP  
Rotor: Thick layer passivated
- **Number of blades:** 7
- **Direction of air flow:** "V", exhaust over struts
- **Direction of rotation:** Counter-clockwise, seen on rotor
- **Type of protection:** IP 54
- **Insulation class:** "B"
- **Mounting position:** Any
- **Condensate discharges:** None, open rotor
- **Operation mode:** Continuous operation (S1)
- **Bearings:** Maintenance-free ball bearings

Nominal data		Curve	Nominal voltage	Frequency	Speed / rpm <sup>(1)</sup>	Max. input power <sup>(1)</sup>	Max. current draw <sup>(1)</sup>	Max. back-pressure	Perm. amb. temp.	Mass	Technical features and electrical connection
Type	Motor	VAC	Hz	rpm	W	A	Pa	°C	kg		
<b>W3G250-HH07 -01</b>	M3G 055-CF	Ⓐ 1~230	50/60	2330	83	0,72	100	-25...+60	2,0	p. 256 / H3)	
<b>W3G250-HH07 -03</b>	M3G 055-CF	Ⓑ 1~230	50/60	2330	83	0,72	100	-25...+60	2,1	p. 257 / H4)	

Subject to alternations

<sup>(1)</sup> Nominal data in operating point with maximum load and 230 VAC

Curve:

- Ⓐ 2 Speed stages
- Ⓑ Speed-controlled

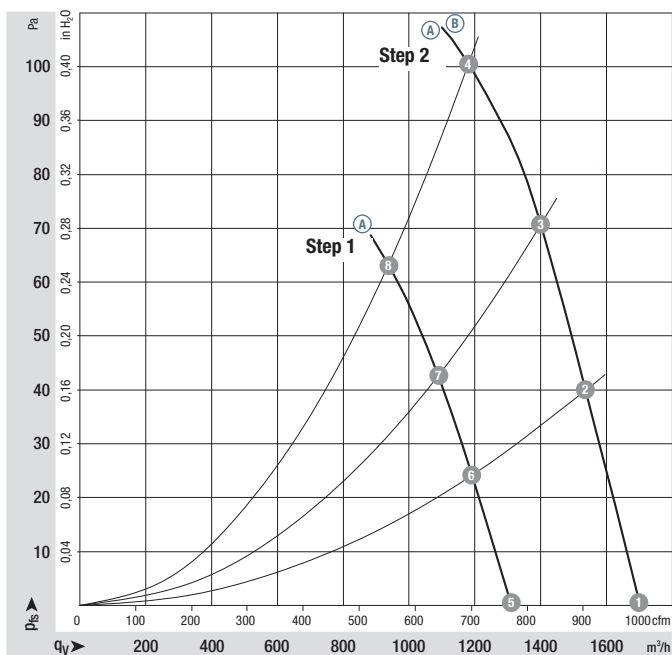

	n rpm	P <sub>ed</sub> W	I A	L <sub>WA</sub> dB(A)
Ⓐ 1	2465	67	0,59	69
Ⓐ 2	2410	75	0,65	69
Ⓐ 3	2375	80	0,68	68
Ⓐ 4	2330	83	0,72	69
Ⓐ 5	1900	33	0,33	63
Ⓐ 6	1880	37	0,37	63
Ⓐ 7	1860	40	0,38	62
Ⓐ 8	1850	42	0,40	63
Ⓑ 1	2465	67	0,59	69
Ⓑ 2	2410	75	0,65	69
Ⓑ 3	2375	80	0,68	68
Ⓑ 4	2330	83	0,72	69

Air performance measured as per: ISO 5801, Installation category A, without protection against accidental contact. Suction-side noise levels: LWA as per ISO 13347, LpA measured at 1 m distance to fan axis. The acoustic values given are only valid under the measurement conditions listed and may vary depending on the installation situation. With any deviation to the standard setup, the specific values have to be checked and reviewed once installed or fitted! For detailed information see <http://www.ebmpapst.com/general conditions>

- **Technical features:** See electrical connections p. 256/257
- **EMC:** Interference immunity acc. to EN 61000-6-2 (industrial environment)  
Harmonics acc. to EN 61000-3-2/3  
Interference emission acc. to EN 55022 (class B, household environment)  
On account of the installation conditions, ferritic damping in the connection line may be required for the application.
- **Touch current:**  $\leq 3.5$  mA acc. to IEC 60990 (test circuit, illustration 4)
- **Electrical connection:** Via terminal strip
- **Protection class:** I (if customer has provided connection for protective earth)
- **Product conforming to standards:** EN 60335-1, CE
- **Approvals:** cURus

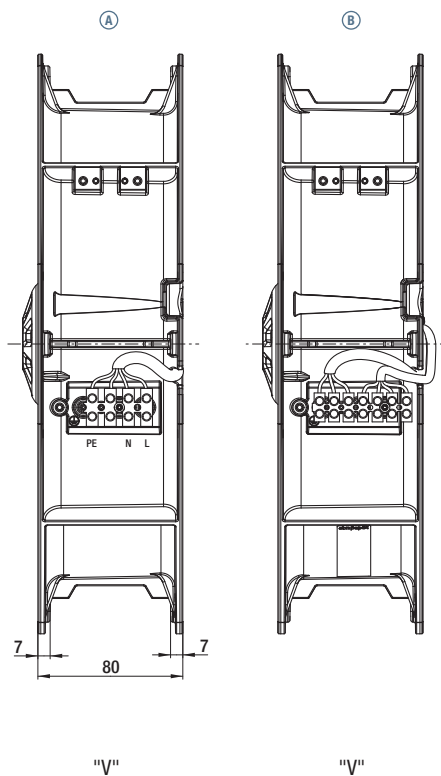
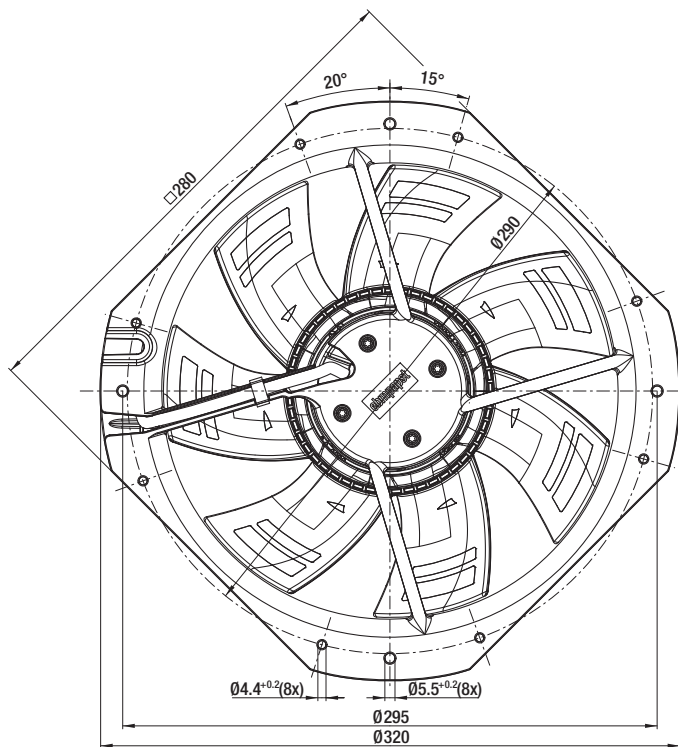

max. 105 m<sup>3</sup>/h

# ACmaxx in-line duct fan

Series AC 100 NR Ø 98,5 x 130 mm



- **Material:** Housing: GRP<sup>1)</sup> (PBT)  
Impeller: GRP<sup>1)</sup> (PA)
- **Direction of air flow:** Intake over struts
- **Direction of rotation:** Clockwise, seen on rotor
- **Connection:** Via 3-pin Europa terminal strip  
max. 1,5 mm<sup>2</sup>
- **Highlights:** Universally usable for all mains voltages between 85 and 265 VAC, 50-60 Hz  
Boost function  
Vibration-isolated motor
- **Mass:** 400 g

- **Possible special versions:**  
(See chapter DC fans - specials)
  - Protection against moisture
  - Type of protection: IP 44 (IP 45 possible depending on mounting position)

1) Fibreglass-reinforced plastic

Nominal data		Air flow	Air flow	Nominal voltage	Frequency	Voltage range	Sound pressure level	Sound power level	Sinter sleeve bearings Ball bearings	Input power	Nominal speed	Temperature range	Service life L <sub>10</sub> at 40 °C	at T <sub>max</sub>	Curve
Type		m <sup>3</sup> /h	CFM	V	Hz	VAC	dB(A)	Bel(A)	□ / ■	Watts	rpm	°C	Hours	Hours	
nominal boost AC 100 NR		80	47	115/230	50-60	85...265	35	4,7	■	2,5	2 750	-10...+55	70 000 / 40 000		①
		105	62				42	5,3		4,5	3 500				②

Subject to alternations

**Optional:** Max. speed up to 135 m<sup>3</sup>/h (Curve 3).

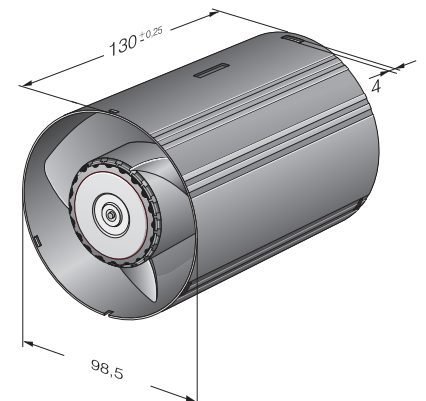
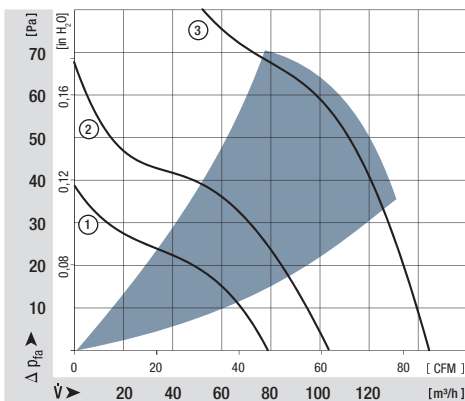

**Highest energy efficiency:** 0.03 - 0.045 W/m<sup>3</sup>/h free air (Specific fan power).  
**Boost speed setting:** 2 speed settings possible via boost function.  
**Vibration isolation:** Reduced transmission of vibrations from motor to housing.  
**Intelligence:** Speed settings and control outputs optional.

## Connection



### Example 1:

Continuous operation at nominal speed boost speed via light switch.

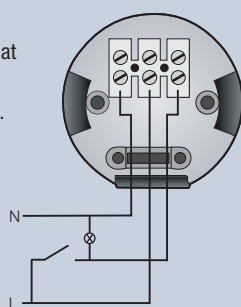

### Example 2:

Nominal speed via light switch, separate boost switch.

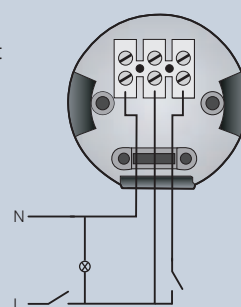

### Example 3:

Simple connection, nominal speed without switching.

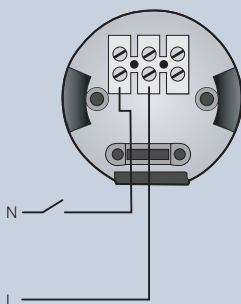

### Example 4:

Simple connection, boost speed without switching.

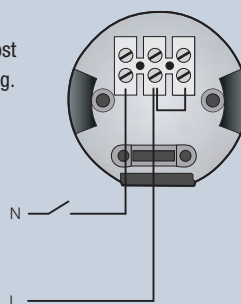

## Scope of delivery

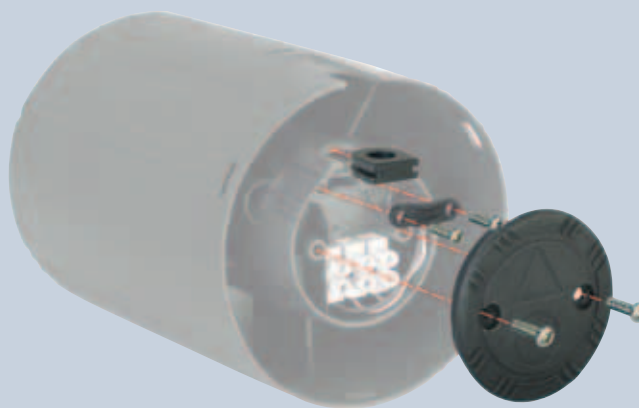



# AC axial fans



AC axial fan overview  
AC axial fans

203  
204

# AC axial fans

## Technical information



### Product line

The renowned ebm-papst AC fans are used when DC voltage is not available. The AC range of fans is based on experience gained from decades of development activity, millions of units in series production and competence in innovation of a world-wide technological leader.

A wide range of fans for AC operation is presented in this catalogue. In addition to complete device fans, you will also find fans without external housing, providing a particularly economical advantage when the air duct can be integrated in the respective device.

### Variety of sizes

AC fans are available in a variety of sizes with either air exhaust or air intake over struts. Silent running models with sleeve bearings (or for extreme ambient conditions) fans with ball bearings are available. Electrical connection with plug connection or external leads are available.

### Shaded-pole or capacitor motors

Fan drives by shaded-pole or capacitor motors, most of which incorporate the world-famous ebm-papst external rotor principle: The fan blades are directly attached to the external rotor of the external rotor motor, thus combining both high performance and profitability.

### Flat built AC fans

ebm-papst also has particularly flat built AC fans with internal rotor motor. Their advantage: quick start to full speed. A plastic impeller and the both smaller and lighter internal rotor motor lead to a lower moment of inertia.

### Bearings

AC fans with sleeve bearings are powered by Class E insulated motors. Fans with ball bearings are equipped with Class B, E or F insulated motors.

### Type of protection

All fans are equipped with type of protection IP 20 as standard. IP 54 / IP 68 and further types of protection are available on request.

### AC voltage

The line of AC fans for Euro voltage according to IEC 60038 (230 V + 6 %, -10 %) is basically also available for 115 V.

### Frequencies

AC fans can be operated at frequencies of 50 Hz or 60 Hz. However, their technical data then changes accordingly.

### Capacitor

Fans driven by capacitor external motors provide particularly high operating efficiency. Generally, the required operating capacitor is already integrated in the fan housing.

### Overloading

Almost all AC fans are protected against overloading (e.g. due to locked rotor) the drive motors are either impedance protected (marked "Impedance protected", and/or "Z.P.") or are equipped with a thermal switch (marked "Thermally protected" or "Th.P."). The model designation of these fans ends with "S".



# Axial fans for AC operation

## Overview of air performance

Dimension	Series	Air flow	Air flow (m³/h)												Page					
			10	20	30	40	50	60	70	80	90	100	200	300		400	500	600	700	800
□ 80 x 38	8000 N	30...61	[Performance chart data]												204					
∅ 76 x 37	8000 TV	24...47	[Performance chart data]												205					
□ 92 x 25	3900	31...70	[Performance chart data]												206					
□ 92 x 38	3000	49...89	[Performance chart data]												207					
□ 119 x 25	9900	84...135	[Performance chart data]												208					
□ 119 x 38	4000 N	80...180	[Performance chart data]												209					
□ 119 x 38	4000 Z	100...180	[Performance chart data]												210					
∅ 108 x 37	4600 TZ	125...140	[Performance chart data]												211					
□ 127 x 38	5900	150...206	[Performance chart data]												212					
□ 135 x 38	5600	235...270	[Performance chart data]												213					
150 x 172 x 38	7000	320...380	[Performance chart data]												214					
∅ 150 x 55	7800	325...380	[Performance chart data]												215					
∅ 150 x 55	7400	380...425	[Performance chart data]												216					
∅ 172 x 51	6000	375...500	[Performance chart data]												217					
□ 225 x 80	W2E 200	880...1030	[Performance chart data]												218					
□ 280 x 80	W2E 250	1865	[Performance chart data]												219					
∅ 200	K2E 200	765...840	[Performance chart data]												220					
∅ 200	K2E 200	765...850	[Performance chart data]												222					
∅ 200	K2D 200	780...880	[Performance chart data]												224					

Subject to alternations

## Overview of technically feasible designs

Dimension	VDE, UL, CSA	Slider, sleeve bearings/ ball bearings	Speed signal	Humidity protection	IP >= IP 54	IP >= IP 68	Salt fog protection	Page
<b>Axial fan</b>								
8000 N	80 x 80 x 38	ja □/■	-	• • • •	• • • •	• • • •	• • • •	204
8000 TV	∅ 76 x 37	ja □/■	-	• • • •	• • • •	• • • •	• • • •	205
3900	92 x 92 x 25	ja □/■	-	•	-	-	-	206
3000	92 x 92 x 38	ja □/■	-	• • • •	• • • •	• • • •	• • • •	207
9900	119 x 119 x 25	ja □/■	-	•	-	-	-	208
4000 N	119 x 119 x 38	ja □/■	•	• • • •	• • • •	• • • •	• • • •	209
4000 Z	119 x 119 x 38	ja □/■	•	• • • •	• • • •	• • • •	• • • •	210
4600 TZ	∅ 108 x 37	ja □/■	-	• • • •	• • • •	• • • •	• • • •	211
5900	127 x 127 x 38	ja □/■	-	•	-	-	-	212
5600	135 x 135 x 38	ja ■	-	• •	-	•	•	213
7000	150 x 172 x 38	ja ■	-	-	-	-	-	214
7800	∅ 150 x 55	ja ■	•	-	-	-	-	215
7400	∅ 150 x 55	ja ■	-	-	-	-	-	216
6000	∅ 172 x 51	ja ■	-	-	-	-	-	217

Subject to alternations

• available    - not yet available    □ Sleeve bearings    ■ Ball bearings

max. 61 m<sup>3</sup>/h

# AC axial fans

Series 8000 N 80 x 80 x 38 mm



- **Material:** Housing: Die-cast aluminium  
Impeller: Painted sheet steel
- **Direction of air flow:** Exhaust over struts
- **Direction of rotation:** Clockwise, seen on rotor
- **Connection:** Via 2 single wires  
grounding lug for M4 x 8
- **Mass:** 490 g
- **Note:** Please note our new ACmaxx series. With identical mounting dimensions and voltages, this series achieves higher energy efficiency. See page 184
- **Possible special versions:** (See page 12)
  - Protection against moisture
  - Protection against salt fog
  - Type of protection: IP 54 / IP 68

Nominal data	Air flow		Nominal voltage	Frequency	Sound pressure level	Sound power level	Sinter sleeve bearings Ball bearings	Input power	Nominal speed	Temperature range	Service life L <sub>10</sub>		Curve
	m <sup>3</sup> /h	CFM									at 40 °C	at T <sub>max</sub>	
Type	m <sup>3</sup> /h	CFM	V	Hz	dB(A)	Bel(A)	□/■	Watts	rpm	°C	Hours	Hours	
8880 N	30	17,7	230	50	18	3,3	□/	9,0	1 750	-10...+80	60 000 / 25 000		①
8850 N	37	21,8	230	50	24	3,9	□/	12,5	2 150	-10...+70	52 500 / 25 000		②
8550 N	50	29,4	230	50	30	4,4	□/	12,0	2 700	-10...+70	52 500 / 25 000		③
8556 N	50	29,4	230	50	31	4,5	/■	12,0	2 800	-40...+90	52 500 / 15 000		③
8830 N	36	21,2	115	60	21	3,7	□/	8,0	1 950	-10...+80	62 500 / 25 000		④
8800 N	47	27,7	115	60	28	4,3	□/	11,0	2 500	-10...+70	55 000 / 27 500		⑤
8500 N	61	35,9	115	60	34	4,8	□/	11,0	3 200	-10...+75	55 000 / 25 000		⑥
8506 N	61	35,9	115	60	35	5,0	/■	11,0	3 300	-40...+95	55 000 / 15 000		⑥

Subject to alternations

Fan type					Lead wires	Length "L"
8880 N	8830 N	8800 N	8550 N	8500 N	310 mm long	AWG 18, TR 64
8556 N	8506 N				310 mm long	AWG 22
8850 N					440 mm long	AWG 18, TR 64

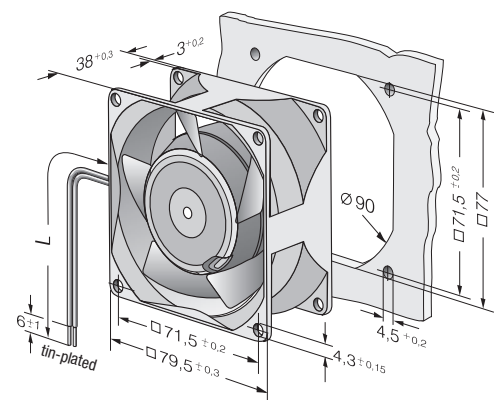
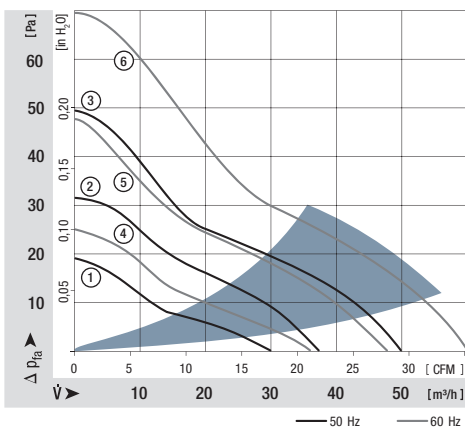

max. 47 m<sup>3</sup>/h

# AC axial fans

Series 8000 TV Ø 76 x 37 mm



- **Material:** Impeller: Die-cast aluminium  
Mounting bracket: Metal
  - **Direction of air flow:** Exhaust over mounting bracket
  - **Direction of rotation:** Clockwise, seen on rotor
  - **Connection:** Via 2 single wires
  - **Mass:** 370 g
- **Possible special versions:** (See page 12)
    - Protection against moisture
    - Protection against salt fog
    - Type of protection: IP 54 / IP 68

Nominal data	Air flow		Nominal voltage	Frequency	Sound pressure level	Sintec sleeve bearings Ball bearings	Input power	Nominal speed	Temperature range	Service life L <sub>10</sub>	
	m <sup>3</sup> /h	CFM								V	Hz
8880 TV	24	14,1	230	50	15	□/■	9,0	1 650	-10...+80	60 000 / 25 000	
8850 TV	31	18,2	230	50	20	□/■	12,0	2 100	-10...+70	52 500 / 25 000	
8550 TV	40	23,5	230	50	27	□/■	12,0	2 650	-10...+70	52 500 / 25 000	
8556 TV	40	23,5	230	50	28	/■	12,0	2 750	-40...+90	52 500 / 15 000	
8830 TV	27	15,9	115	60	18	□/■	8,0	1 850	-10...+80	62 500 / 25 000	
8800 TV	36	21,2	115	60	24	□/■	11,0	2 450	-10...+70	55 000 / 27 500	
8500 TV	47	27,7	115	60	32	□/■	11,0	3 150	-10...+75	55 000 / 25 000	
8506 TV	47	27,7	115	60	33	/■	11,0	3 250	-40...+95	55 000 / 15 000	

Subject to alternations

The air flow and noise level of fans without external housing depends on the installation conditions. The stated air flow and noise has been measured with an orifice 76.5 mm Ø at a distance of approx. 17 mm from the mounting bracket. Under exceptionally favourable mounting conditions, the air flow of fan series 8000 N is achievable. The noise in the optimal operating range can only be measured for these fans in a specific application.

Fan type				Lead wires	Length "L"
8880 TV	8850 TV	8830 TV	8800 TV	325 mm long	AWG 18, TR 64
8550 TV	8500 TV			325 mm long	AWG 18, TR 64
8556 TV	8506 TV			325 mm long	AWG 18

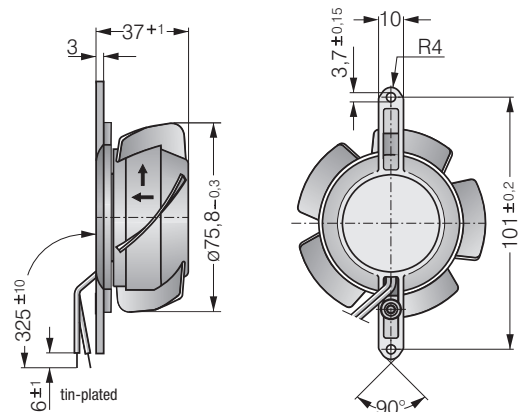

max. 70 m<sup>3</sup>/h

# AC axial fans

Series 3900 92 x 92 x 25 mm



- **Material:** Housing: Die-cast aluminium  
Impeller: Mineral-reinforced plastic PA
- **Direction of air flow:** Exhaust over struts
- **Direction of rotation:** Counter-clockwise, seen on rotor
- **Connection:** Via 2 flat plug 2,8 x 0,5 mm grounding lug for M4
- **Mass:** 280 g
- **Note:** Please note our new ACmaxx series. With identical mounting dimensions and voltages, this series achieves higher energy efficiency. See page 185

- **Possible special versions:**  
(See page 12)  
- Protection against moisture

Nominal data	Air flow		Nominal voltage	Frequency	Sound pressure level	Sound power level	Sinter sleeve bearings Ball bearings	Input power	Nominal speed	Temperature range	Service life L <sub>10</sub>		Curve
	m <sup>3</sup> /h	CFM									at 40 °C	at T <sub>max</sub>	
Type	m <sup>3</sup> /h	CFM	V	Hz	dB(A)	Bel(A)	□/■	Watts	rpm	°C	Hours	Hours	
3950 L	31	18,2	230	50	24	3,8	□/	6,0	1 550	-10...+80	70 000 / 27 500		①
3956 L	31	18,2	230	50	24	3,8	/■	6,0	1 550	-40...+80	70 000 / 27 500		①
3950 M	45	26,5	230	50	29	4,2	□/	6,0	2 150	-10...+80	70 000 / 27 500		②
3956 M	45	26,5	230	50	29	4,2	/■	6,0	2 150	-40...+80	70 000 / 27 500		②
3950	59	34,7	230	50	35	4,7	□/	11,0	2 650	-20...+80	55 000 / 20 000		③
3956	59	34,7	230	50	35	4,7	/■	11,0	2 650	-40...+80	55 000 / 20 000		③
3900 L	39	23,0	115	60	27	4,0	□/	5,0	1 850	-10...+80	70 000 / 27 500		④
3906 L	39	23,0	115	60	27	4,0	/■	5,0	1 850	-40...+80	70 000 / 27 500		④
3900 M	53	31,2	115	60	34	4,6	□/	5,0	2 600	-10...+80	70 000 / 27 500		⑤
3906 M	53	31,2	115	60	34	4,6	/■	5,0	2 600	-40...+80	70 000 / 27 500		⑤
3900	70	41,2	115	60	40	5,1	□/	9,0	3 150	-20...+80	60 000 / 22 500		⑥
3906	70	41,2	115	60	40	5,1	/■	9,0	3 150	-40...+80	60 000 / 22 500		⑥

Subject to alternations

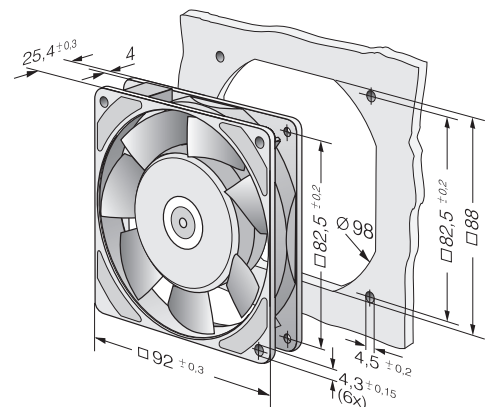
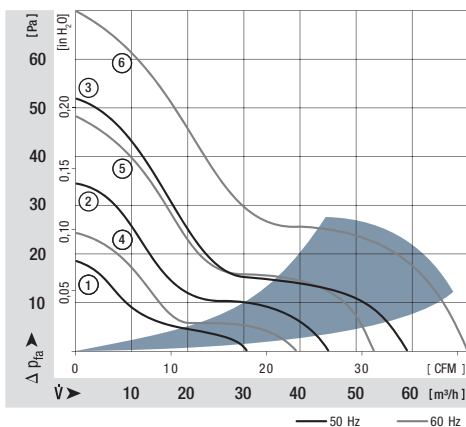

max. 89 m<sup>3</sup>/h

# AC axial fans

Series 3000 92 x 92 x 38 mm



- **Material:** Housing: Die-cast aluminium  
Impeller: Painted sheet steel
- **Direction of air flow:** Exhaust over struts
- **Direction of rotation:** Clockwise, seen on rotor
- **Connection:** Via 2 single wires  
grounding lug for M4 x 8
- **Mass:** 420 g
- **Note:** Please note our new ACmaxx series. With identical mounting dimensions and voltages, this series achieves higher energy efficiency. See page 185
- **Possible special versions:** (See page 12)
  - Protection against moisture
  - Protection against salt fog
  - Type of protection: IP 54 / IP 68

Nominal data	Air flow		Nominal voltage	Frequency	Sound pressure level	Sound power level	Sintec sleeve bearings Ball bearings	Input power	Nominal speed	Temperature range	Service life L <sub>10</sub>		Curve
	m <sup>3</sup> /h	CFM									Hours	Hours	
Type	m <sup>3</sup> /h	CFM	V	Hz	dB(A)	Bel(A)	□/■	Watts	rpm	°C	Hours	Hours	
3850	49	28,8	230	50	24	3,7	□/	9,0	1 750	-10...+75	60 000 / 27 500	①	
3856	54	31,8	230	50	26	3,9	/■	9,0	1 950	-40...+90	60 000 / 20 000	②	
3550	67	39,4	230	50	32	4,4	□/	8,5	2 300	-10...+80	60 000 / 25 000	③	
3556	67	39,4	230	50	33	4,5	/■	8,5	2 400	-40...+90	60 000 / 20 000	③	
3650	75	44,1	230	50	36	4,8	□/	12,0	2 650	-10...+55	52 500 / 37 500	④	
3656	75	44,1	230	50	37	4,9	/■	12,0	2 700	-40...+75	52 500 / 22 500	④	
3800	54	31,8	115	60	26	3,9	□/	8,0	1 900	-10...+80	62 500 / 25 000	⑤	
3806	60	35,3	115	60	29	4,2	/■	8,0	2 150	-40...+95	62 500 / 17 500	⑥	
3500	73	43,0	115	60	35	4,6	□/	8,0	2 500	-10...+80	62 500 / 25 000	⑦	
3506	73	43,0	115	60	36	4,7	/■	8,0	2 600	-40...+95	62 500 / 17 500	⑦	
3600	89	52,4	115	60	41	5,1	□/	11,0	3 100	-10...+65	55 000 / 30 000	⑧	
3606	89	52,4	115	60	42	5,2	/■	11,0	3 200	-40...+75	55 000 / 25 000	⑧	

Subject to alternations

Fan type	Lead wires	Length "L"
With sleeve bearings	310 mm long	AWG 18, TR 64
With ball bearings	310 mm long	AWG 18

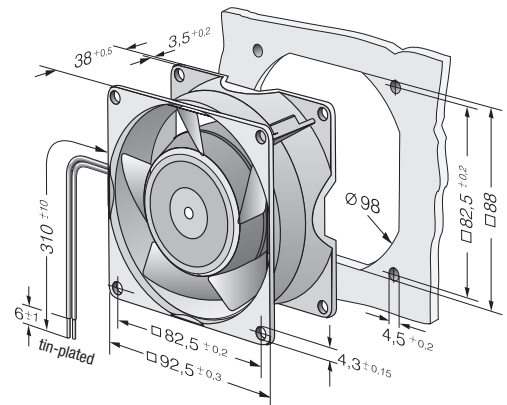
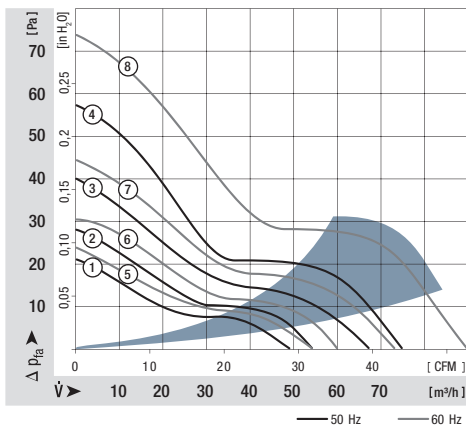

max. 135 m<sup>3</sup>/h

# AC axial fans

Series 9900 119 x 119 x 25 mm



- **Material:** Housing: Die-cast aluminium  
Impeller: Mineral-reinforced plastic PA
- **Direction of air flow:** Exhaust over struts
- **Direction of rotation:** Counter-clockwise, seen on rotor
- **Connection:** Via 2 flat plug 2,8 x 0,5 mm grounding lug for M4
- **Mass:** 320 g
- **Note:** Please note our new ACmaxx series. With identical mounting dimensions and voltages, this series achieves higher energy efficiency. See page 188

- **Possible special versions:**  
(See page 12)  
- Protection against moisture

Nominal data	Air flow		Nominal voltage	Frequency	Sound pressure level	Sound power level	Sinter sleeve bearings Ball bearings	Input power	Nominal speed	Temperature range	Service life L <sub>10</sub>		Curve
	m <sup>3</sup> /h	CFM									at 40 °C	at T <sub>max</sub>	
Type	m <sup>3</sup> /h	CFM	V	Hz	dB(A)	Bel(A)	□/■	Watts	rpm	°C	Hours	Hours	
9956 L	84	49,4	230	50	29	4,4	/■	9,5	1850	-40...+80	57 500 / 22 500		①
9956 M	104	61,2	230	50	35	4,7	/■	10,0	2250	-40...+80	57 500 / 22 500		②
9950	117	68,9	230	50	37	5,0	□/	14,0	2450	-20...+70	47 500 / 22 500		③
9956	117	68,9	230	50	37	5,0	/■	14,0	2450	-40...+70	47 500 / 22 500		③
9906 L	100	58,9	115	60	34	4,6	/■	8,0	2100	-40...+80	62 500 / 25 000		④
9906 M	111	65,3	115	60	37	5,0	/■	8,0	2450	-40...+80	62 500 / 25 000		⑤
9900	135	79,5	115	60	42	5,4	□/	12,0	2850	-20...+70	52 500 / 25 000		⑥
9906	135	79,5	115	60	42	5,4	/■	12,0	2850	-40...+70	52 500 / 25 000		⑥

Subject to alternations

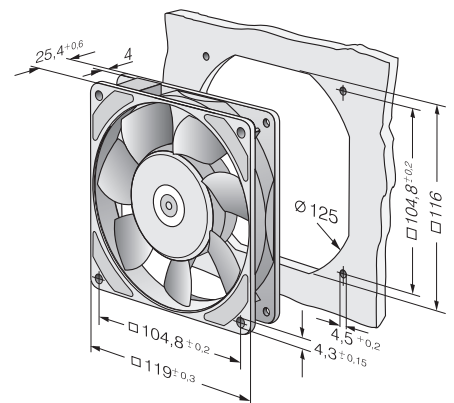
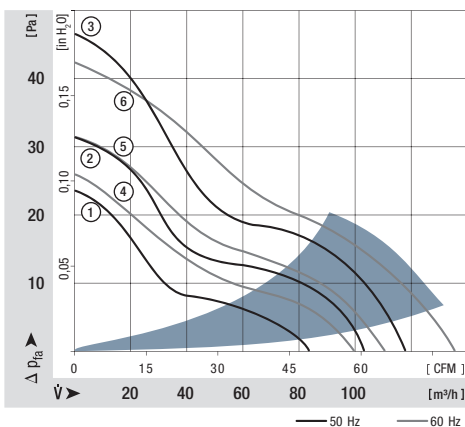



max. 180 m<sup>3</sup>/h

# AC axial fans

Series 4000 N 119 x 119 x 38 mm



- **Material:** Housing: Die-cast aluminium  
Impeller: Painted sheet steel
- **Direction of air flow:** Intake over struts  
Types 4890 N and 4840 N exhaust over struts
- **Direction of rotation:** Clockwise, seen on rotor
- **Connection:** Via 2 single wires  
grounding lug for M4 and UNC
- **Mass:** 550 g
- **Note:** Please note our new ACmaxx series. With identical mounting dimensions and voltages, this series achieves higher energy efficiency. See page 188
- **Optionally available:** Variants with strengthened mounting flanges and customizable single strands
- **Possible special versions:** (See page 12)
  - Speed signal
  - Protection against moisture
  - Protection against salt fog
  - Type of protection: IP 54 / IP 68

Nominal data	Air flow	Air flow	Nominal voltage	Frequency	Sound pressure level	Sound power level	Sintec sleeve bearings	Ball bearings	Input power	Nominal speed	Temperature range	Service life L <sub>10</sub> at 40 °C	at T <sub>max</sub>	Curve
Type	m <sup>3</sup> /h	CFM	V	Hz	dB(A)	Bel(A)	□/■	Watts	rpm	°C	Hours	Hours		
4890 N	80	47	230	50	25	4,0	□/	11,0	1 550	-10...+70	55 000 / 27 500			①
4850 N*	100	59	230	50	32	4,4	□/	10,0	1 800	-10...+70	57 500 / 27 500			②
4580 N*	123	72	230	50	41	5,2	□/	18,0	2 350	-10...+55	40 000 / 27 500			③
4550 N*	145	85	230	50	44	5,4	□/	16,5	2 550	-10...+55	42 500 / 30 000			④
4650 N	160	94	230	50	46	5,4	□/	19,0	2 650	-10...+55	37 500 / 27 500			⑤
4656 N	160	94	230	50	47	5,5	/■	19,0	2 650	-40...+85	37 500 / 15 000			⑤
4840 N	85	50	115	60	26	4,1	□/	10,0	1 650	-10...+75	57 500 / 25 000			⑥
4800 N*	97	57	115	60	32	4,3	□/	9,0	1 750	-10...+75	60 000 / 27 500			⑦
4530 N*	151	89	115	60	45	5,4	□/	16,0	2 700	-10...+65	42 500 / 25 000			⑧
4500 N*	169	100	115	60	48	5,7	□/	15,0	3 000	-10...+65	47 500 / 25 000			⑨
4600 N	180	106	115	60	50	5,7	□/	18,0	3 100	-10...+60	40 000 / 25 000			⑩
4606 N	180	106	115	60	51	5,8	/■	18,0	3 100	-40...+90	40 000 / 15 000			⑩

Subject to alternations

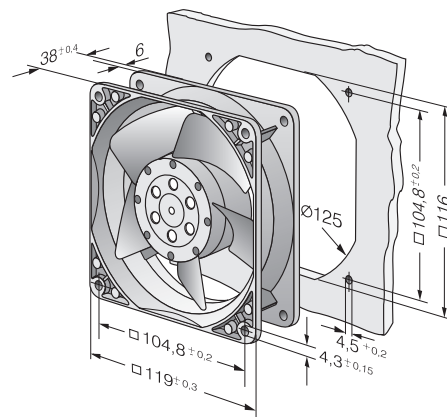
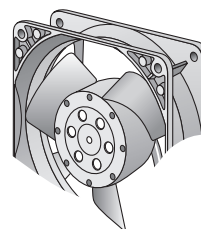
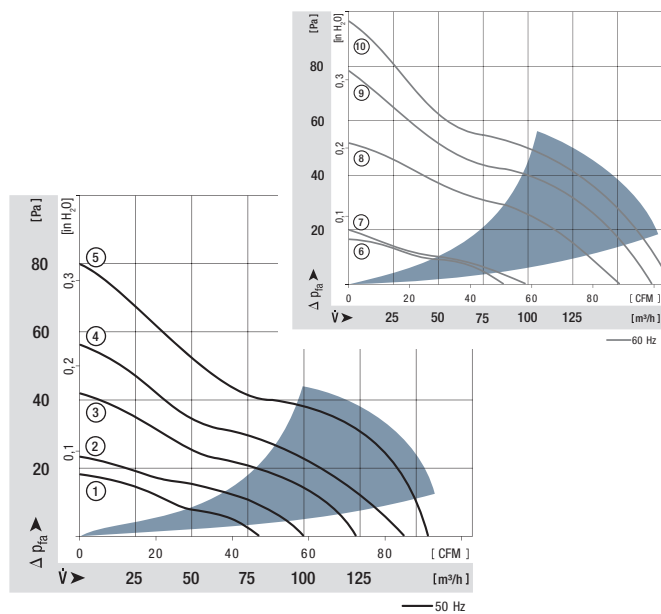



max. 180 m<sup>3</sup>/h

# AC axial fans

Series 4000 Z 119 x 119 x 38 mm



- **Material:** Housing: Die-cast aluminium  
Impeller: Painted sheet steel
  - **Direction of air flow:** Exhaust over struts
  - **Direction of rotation:** Clockwise, seen on rotor
  - **Connection:** Via 2 flat plug 2,8 x 0,5 mm  
grounding lug for M4 x 8
  - **Mass:** 540 g
  - **Note:** Please note our new ACmaxx series. With identical mounting dimensions and voltages, this series achieves higher energy efficiency. See page 188
- **Possible special versions:** (See page 12)
    - Speed signal
    - Protection against moisture
    - Protection against salt fog
    - Type of protection: IP 54 / IP 68

Nominal data	Air flow		Nominal voltage	Frequency	Sound pressure level	Sound power level	Sinter sleeve bearings Ball bearings	Input power	Nominal speed	Temperature range	Service life L <sub>10</sub>		Curve
	m <sup>3</sup> /h	CFM									at 40 °C	at T <sub>max</sub>	
Type	m <sup>3</sup> /h	CFM	V	Hz	dB(A)	Bel(A)	□/■	Watts	rpm	°C	Hours	Hours	
4850 Z	100	59	230	50	26	4,0	□/	13,0	1 700	-10...+65	50 000 / 27 500		①
4856 Z	100	59	230	50	26	4,0	/■	13,0	1 700	-40...+75	50 000 / 20 000		①
4580 Z	115	68	230	50	30	4,3	□/	13,0	1 900	-10...+65	50 000 / 27 500		②
4586 Z	115	68	230	50	30	4,3	/■	13,0	1 900	-40...+75	50 000 / 20 000		②
4650 Z	160	94	230	50	40	5,3	□/	19,0	2 650	-10...+50	37 500 / 30 000		③
4656 Z	160	94	230	50	40	5,3	/■	19,0	2 650	-40...+75	37 500 / 17 500		③
4800 Z	105	62	115	60	28	4,1	□/	12,0	1 800	-10...+70	52 500 / 25 000		④
4806 Z	105	62	115	60	28	4,1	/■	12,0	1 800	-40...+75	52 500 / 17 500		④
4530 Z	120	71	115	60	32	4,4	□/	12,0	2 000	-10...+70	52 500 / 25 000		⑤
4536 Z	120	71	115	60	32	4,4	/■	12,0	2 000	-40...+75	52 500 / 17 500		⑤
4600 Z	180	106	115	60	45	5,6	□/	18,0	3 100	-10...+60	40 000 / 25 000		⑥
4606 Z	180	106	115	60	45	5,6	/■	18,0	3 100	-40...+85	40 000 / 15 000		⑥

Subject to alternations

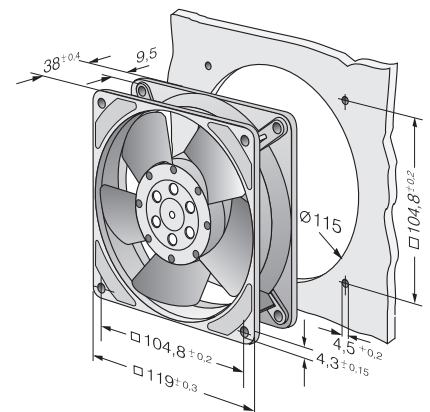
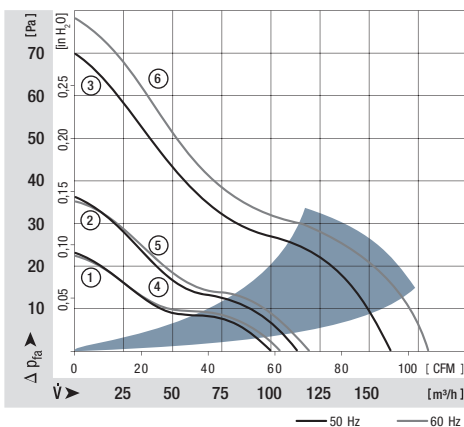

max. 140 m<sup>3</sup>/h

# AC axial fans

Series 4600 TZ Ø 108 x 37 mm



- **Material:** Impeller: Die-cast aluminium  
Mounting bracket: Metal
  - **Direction of air flow:** Exhaust over mounting bracket
  - **Direction of rotation:** Clockwise, seen on rotor
  - **Connection:** Via 2 single wires
  - **Mass:** 430 g
- **Possible special versions:** (See page 12)
    - Protection against moisture
    - Protection against salt fog
    - Type of protection: IP 54 / IP 68

Nominal data	Air flow		Nominal voltage	Frequency	Sound pressure level	Sinter sleeve bearings Ball bearings	Input power	Nominal speed	Temperature range	Service life L <sub>10</sub>	
	m <sup>3</sup> /h	CFM								V	Hz
4650 TZ	125	73,6	<b>230</b>	<b>50</b>	42	□/■	19,0	2 600	-10...+50	37 500 / 30 000	
4656 TZ	125	73,6	<b>230</b>	<b>50</b>	42	/■	19,0	2 600	-40...+65	37 500 / 20 000	
4600 TZ	140	82,4	<b>115</b>	<b>60</b>	45	□/■	18,0	2 950	-10...+50	40 000 / 32 500	
4606 TZ	140	82,4	<b>115</b>	<b>60</b>	45	/■	18,0	2 950	-40...+75	40 000 / 17 500	

Subject to alternations

The air flow and noise level of fans without external housing depends on the installation conditions. The stated air flow and noise has been measured with an orifice 109 mm Ø at a distance of approx. 17 mm from the mounting bracket. Under exceptionally favourable mounting conditions, the air flow of fan series 4000 Z is achievable. The noise in the optimal operating range can only be measured for these fans in a specific application.

Fan type	Lead wires
4650 TZ	4600 TZ
4656 TZ	4606 TZ
	AWG 22, TR 32
	AWG 18

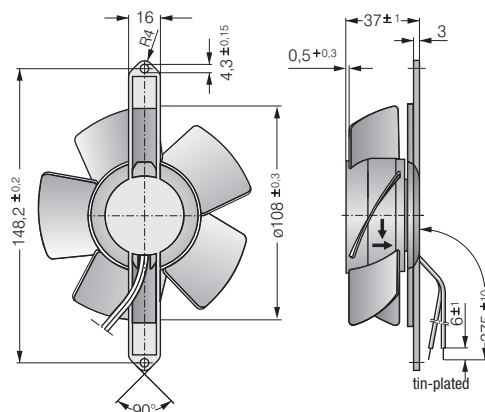

max. 206 m<sup>3</sup>/h

# AC axial fans

Series 5900 127 x 127 x 38 mm



- **Material:** Housing: Die-cast aluminium  
Impeller: GRP<sup>1)</sup> (PA)
  - **Direction of air flow:** Exhaust over struts
  - **Direction of rotation:** Counter-clockwise, seen on rotor
  - **Connection:** Via 2 flat plug 2,8 x 0,5 mm grounding lug for M4 x 6
  - **Mass:** 570 g
- **Possible special versions:**  
(See page 12)  
- Protection against moisture

1) Fibreglass-reinforced plastic

Nominal data	Air flow		Nominal voltage	Frequency	Sound pressure level	Sound power level	Sinter sleeve bearings Ball bearings	Input power	Nominal speed	Temperature range	Service life L <sub>10</sub>		Curve
	m <sup>3</sup> /h	CFM									at 40 °C	at T <sub>max</sub>	
Type	m <sup>3</sup> /h	CFM	V	Hz	dB(A)	Bel(A)	□/■	Watts	rpm	°C	Hours	Hours	
5988	150	88	230	50	37	4,9	/■	13,0	2 250	-30...+55	35 000 / 20 000		①
5950	180	106	230	50	43	5,4	□/	18,0	2 700	-20...+50	40 000 / 32 500		③
5958	180	106	230	50	44	5,5	/■	18,0	2 750	-30...+60	40 000 / 25 000		③
5938	162	95	115	60	40	4,9	/■	12,0	2 500	-30...+55	35 000 / 20 000		②
5900	206	121	115	60	46	5,7	□/	17,0	3 050	-20...+55	42 500 / 30 000		④
5908	206	121	115	60	47	5,8	/■	17,0	3 100	-30...+75	42 500 / 20 000		④

Subject to alternations

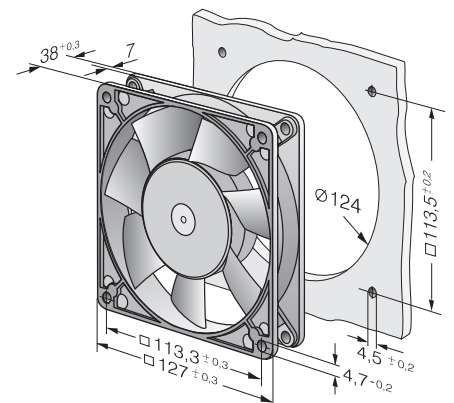
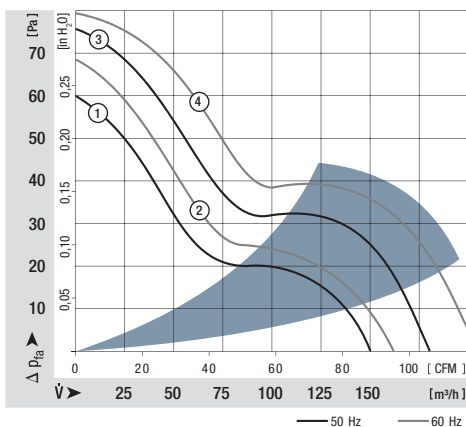

max. 270 m<sup>3</sup>/h

# AC axial fans

Series 5600 135 x 135 x 38 mm



- **Material:** Housing: Die-cast aluminium  
Impeller: Painted sheet steel
  - **Direction of air flow:** Exhaust over struts
  - **Direction of rotation:** Counter-clockwise, seen on rotor
  - **Connection:** Via 2 flat plug 2,8 x 0,5 mm grounding lug for M4 x 8
  - **Mass:** 800 g
- **Possible special versions:** (See page 12)
    - Protection against moisture
    - Protection against salt fog
    - Type of protection: IP 54

Nominal data	Air flow		Nominal voltage	Frequency	Sound pressure level	Sound power level	Sintec sleeve bearings Ball bearings	Input power	Nominal speed	Temperature range	Service life L <sub>10</sub>		Curve
	m <sup>3</sup> /h	CFM									Hours	Hours	
Type	m <sup>3</sup> /h	CFM	V	Hz	dB(A)	Bel(A)	□ / ■	Watts	rpm	°C	Hours	Hours	
5656 S	235	138	230	50	46	5,9	□ / ■	30,0	2 700	-35...+70	45 000 / 20 000		①
5606 S	270	159	115	60	50	6,2	□ / ■	26,0	3 100	-35...+80	47 500 / 20 000		②

Subject to alternations

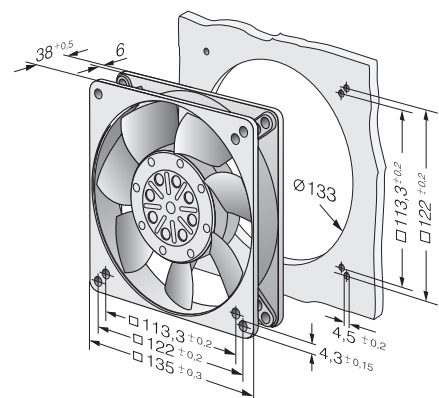
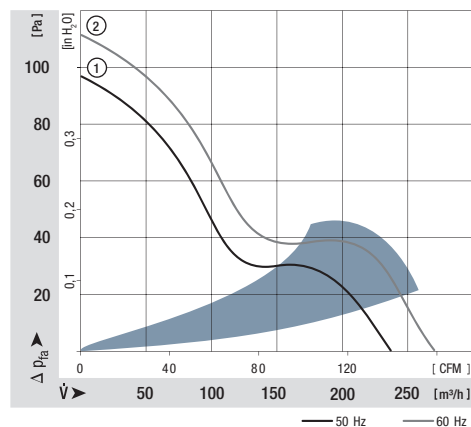

max. 380 m<sup>3</sup>/h

# AC axial fans

Series 7000 150 x 172 x 38 mm



- **Material:** Housing: Die-cast aluminium  
Impeller: Painted sheet steel
- **Direction of air flow:** Exhaust over struts
- **Direction of rotation:** Counter-clockwise, seen on rotor
- **Connection:** Via 2 flat plug 2,8 x 0,5 mm grounding lug for M4 x 8
- **Mass:** 900 g
- **Note:** Please note our new ACmaxx series. With identical mounting dimensions and voltages, this series achieves higher energy efficiency. See page 190, 192, 193

Nominal data	Air flow		Nominal voltage	Frequency	Sound pressure level	Sound power level	Sinter sleeve bearings Ball bearings	Input power	Nominal speed	Temperature range	Service life L <sub>10</sub>		Curve
	m <sup>3</sup> /h	CFM									at 40 °C	at T <sub>max</sub>	
Type	m <sup>3</sup> /h	CFM	V	Hz	dB(A)	Bel(A)	□/■	Watts	rpm	°C	Hours	Hours	
7056 ES	320	188	230	50	51	6,4	/■	27,0	2 800	-25...+55	60 000 / 32 000		①
7006 ES	380	224	115	60	56	6,8	/■	28,0	3 350	-25...+65	55 000 / 18 000		②

Subject to alternations

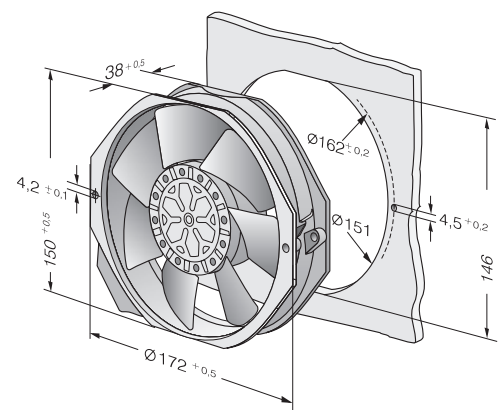
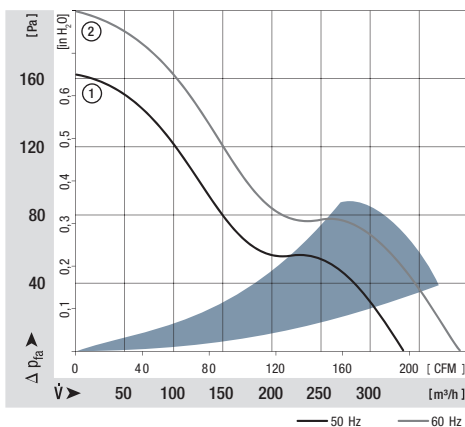

max. 380 m<sup>3</sup>/h

# AC axial fans

Series 7800 Ø 150 x 55 mm



- **Material:** Housing: Die-cast aluminium  
Impeller: Painted sheet steel
- **Direction of air flow:** Exhaust over struts
- **Direction of rotation:** Counter-clockwise, seen on rotor
- **Connection:** Via 2 single wires, wire ends with brass lead tips grounding lug for M4 x 8
- **Mass:** 1,1 kg
- **Note:** Please note our new ACmaxx series. With identical mounting dimensions and voltages, this series achieves higher energy efficiency. See page 190

Nominal data	Air flow		Nominal voltage	Frequency	Sound pressure level	Sound power level	Sinter sleeve bearings Ball bearings	Input power	Nominal speed	Temperature range	Service life L <sub>10</sub>		Curve
	m <sup>3</sup> /h	CFM									at 40 °C	at T <sub>max</sub>	
Type	m <sup>3</sup> /h	CFM	V	Hz	dB(A)	Bel(A)	□/■	Watts	rpm	°C	Hours	Hours	
7855 ES	325	191	230	50	49	6,0	/■	45,0	2 800	-25...+50	60 000 / 47 500		①
7856 ES	325	191	230	50	49	6,0	/■	45,0	2 800	-25...+70	60 000 / 30 000		①
7805 ES	380	224	115	60	53	6,4	/■	38,0	3 250	-25...+70	60 000 / 47 500		②
7806 ES	380	224	115	60	53	6,4	/■	38,0	3 250	-25...+90	60 000 / 15 000		②

Subject to alternations

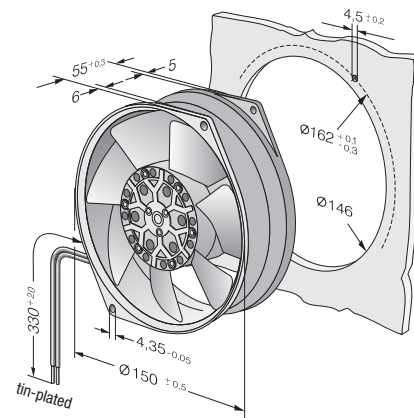
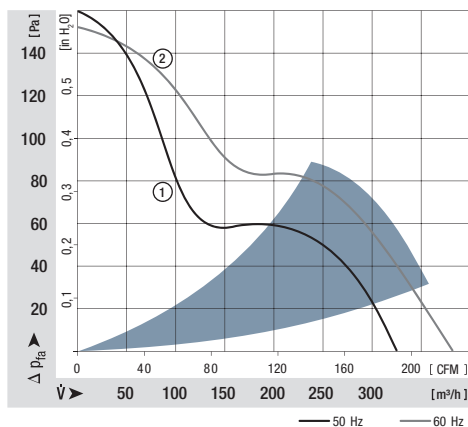

max. 425 m<sup>3</sup>/h

# AC axial fans

Series 7400 Ø 150 x 55 mm



- **Material:** Housing: Die-cast aluminium  
Impeller: Painted sheet steel
- **Direction of air flow:** Exhaust over struts
- **Direction of rotation:** Counter-clockwise, seen on rotor
- **Connection:** Via 2 single wires, wire ends with brass lead tips grounding lug for M4 x 8
- **Mass:** 1,1 kg
- **Note:** Please note our new ACmaxx series. With identical mounting dimensions and voltages, this series achieves higher energy efficiency. See page 190

Nominal data	Air flow		Nominal voltage	Frequency	Sound pressure level	Sound power level	Sinter sleeve bearings Ball bearings	Input power	Nominal speed	Temperature range	Service life L <sub>10</sub>		Curve
	m <sup>3</sup> /h	CFM									at 40 °C	at T <sub>max</sub>	
Type	m <sup>3</sup> /h	CFM	V	Hz	dB(A)	Bel(A)	□/■	Watts	rpm	°C	Hours	Hours	
7450 ES	380	224	230	50	60	6,8	/■	47,0	2 700	-25...+50	63 000 / 50 000		①
7400 ES	425	250	115	60	62	6,9	/■	46,0	3 050	-25...+70	50 000 / 24 000		②

Subject to alternations

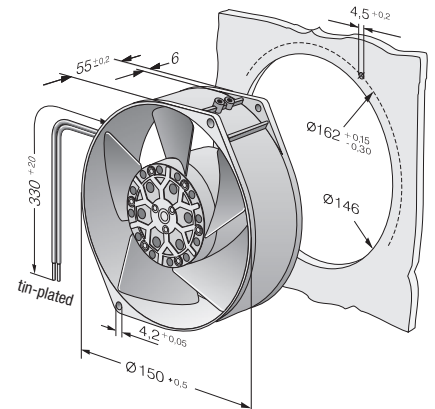
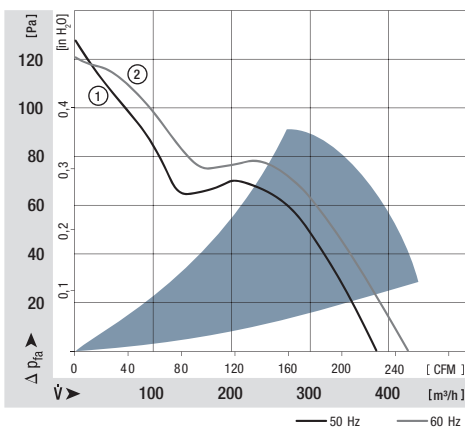



max. 500 m<sup>3</sup>/h

# AC axial fans

Series 6000 Ø 172 x 51 mm



- **Material:** Housing: Die-cast aluminium  
Impeller: Painted sheet steel
- **Direction of air flow:** Exhaust over struts
- **Direction of rotation:** Counter-clockwise, seen on rotor
- **Connection:** Via 2 flat plug 2,8 x 0,5 mm grounding lug for M4 x 6
- **Mass:** 1,0 kg
- **Note:** Please note our new ACmaxx series. With identical mounting dimensions and voltages, this series achieves higher energy efficiency. See page 192,193

Nominal data	Air flow		Nominal voltage	Frequency	Sound pressure level	Sound power level	Sinter sleeve bearings Ball bearings	Input power	Nominal speed	Temperature range	Service life L <sub>10</sub>		Curve
	m <sup>3</sup> /h	CFM									Hours	Hours	
Type	m <sup>3</sup> /h	CFM	V	Hz	dB(A)	Bel(A)	□/■	Watts	rpm	°C	Hours	Hours	
6058 ES	375	221	230	50	55	5,9	/■	24,0	2 800	-25...+70	62 000 / 31 000		①
6078 ES	420	247	230	50	54	6,3	/■	26,0	2 800	-25...+60	62 000 / 39 000		②
6008 ES	440	259	115	60	60	6,4	/■	26,0	3 300	-25...+70	57 000 / 28 000		③
6028 ES	500	284	115	60	58	6,7	/■	29,0	3 300	-25...+75	57 000 / 22 000		④

Subject to alternations

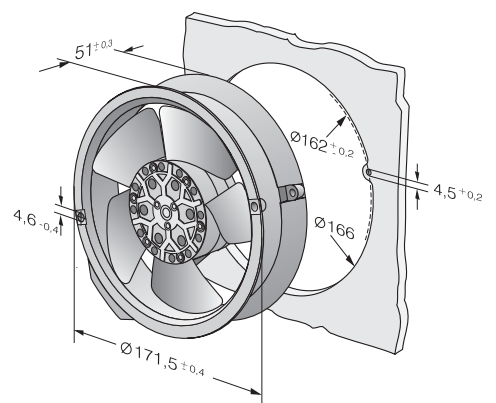
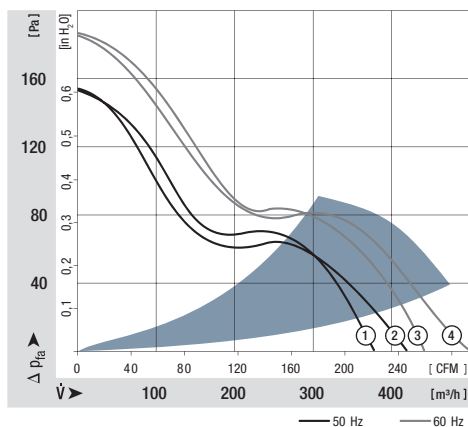

max. 1030 m<sup>3</sup>/h

# AC axial fans

225 x 225 x 80 mm



- **Material:** Housing: Die-cast aluminium  
Impeller: Sheet steel
- **Number of blades:** 7
- **Direction of air flow:** Exhaust over struts
- **Direction of rotation:** Counter-clockwise, seen on rotor
- **Type of protection:** IP44, depending on installation and position
- **Insulation class:** "B"
- **Mounting position:** Any
- **Connection:** Terminal strips (operating capacitor connected)
- **Mass:** 2,0 kg
- **Operation mode:** Continuous operation (S1)
- **Bearings:** Maintenance-free ball bearings

Nominal data	Air flow		Nominal voltage	Frequency	Sound pressure level	Sound power level	Sinter sleeve bearings Ball bearings	Input power	Speed / rpm	Perm. amb. temp.	Service life L <sub>10</sub>		Curve
	m <sup>3</sup> /h	CFM									at 40 °C	at T <sub>max</sub>	
Type	m <sup>3</sup> /h	CFM	V	Hz	dB(A)	Bel(A)	□/■	Watts	rpm	°C	Hours	Hours	
W2E 200-HK86-01	1030	606	115	60	61	6,7	□/■	80,0	2800	-25...+65	60 000 / 58 000		①
W2E 200-HK38-01	880	518	230	50	58	6,6	■	64,0	2550	-25...+60	63 000 / 60 000		①

Subject to alternations

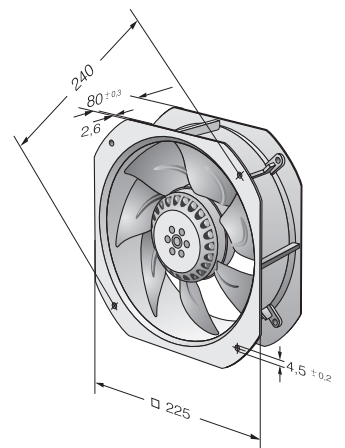
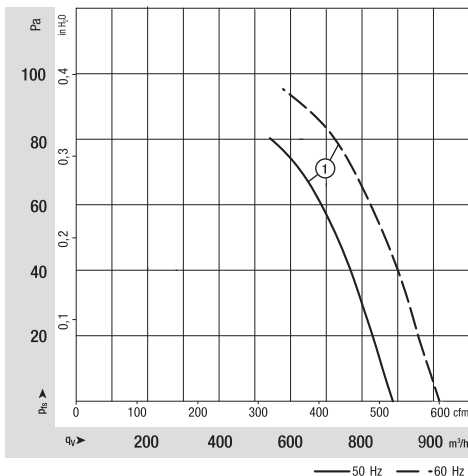

max. 1865 m<sup>3</sup>/h

# AC axial fans

280 x 280 x 80 mm



- **Material:** Housing: Die-cast aluminium  
Impeller: Sheet steel
- **Number of blades:** 7
- **Direction of air flow:** Exhaust over struts
- **Direction of rotation:** Counter-clockwise, seen on rotor
- **Type of protection:** IP44, depending on installation and position
- **Insulation class:** "F"
- **Mounting position:** Any
- **Connection:** Terminal strips (operating capacitor connected)
- **Mass:** 2,0 kg
- **Operation mode:** Continuous operation (S1)
- **Bearings:** Maintenance-free ball bearings

Nominal data	Air flow		Nominal voltage	Frequency	Sound pressure level	Sound power level	Sinter sleeve bearings Ball bearings	Input power	Speed / rpm	Perm. amb. temp.	Service life L <sub>10</sub>		Curve
	m <sup>3</sup> /h	CFM									Hours	Hours	
Type	m <sup>3</sup> /h	CFM	V	Hz	dB(A)	Bel(A)	□ / ■	Watts	rpm	°C	Hours	Hours	
W2E 250-HL06-01	1865	1077	230	50	66	7,2	□ / ■	127,0	2 550	-25...+60	63 000 / 70 000		①

Subject to alternations

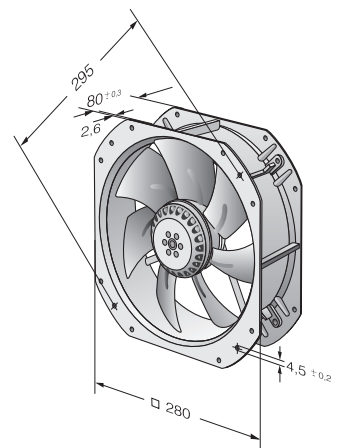
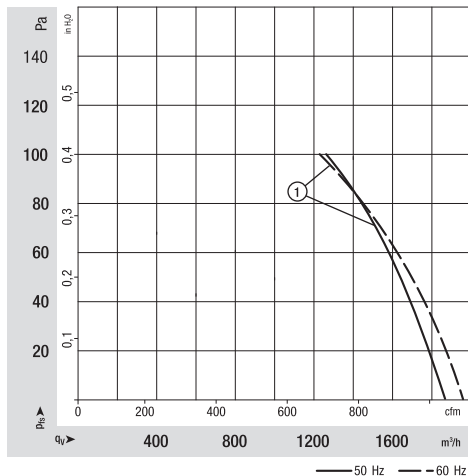

max. 850 m<sup>3</sup>/h

# AC diagonal module

Ø 200 mm



- **Material:** Housing: Plastic PA  
Support bracket: Plastic PA  
Impeller: Plastic PA  
Rotor: Coated in black
- **Number of blades:** 7
- **Direction of air flow:** "V"
- **Direction of rotation:** Clockwise, seen on rotor
- **Type of protection:** IP 44, depending on installation and position
- **Insulation class:** "F"
- **Mounting position:** Any
- **Condensate discharges:** None
- **Operation mode:** Continuous operation (S1)
- **Bearings:** Maintenance-free ball bearings

Nominal data		Curve	Nominal voltage	Frequency	Air flow	Speed / rpm	Input power	Input current	Capacitor	Sound pressure level	Max. back-pressure	Perm. amb. temp.	Mass	Electrical connection
Type	Motor	VAC	Hz	m <sup>3</sup> /h	rpm	W	A	µF/VDB	dB(A)	Pa	°C	kg		
K2E 200-AA12 -01	M2E 068-CF	(A) 1 ~ 115	50	765	2650	64	0,56	6,0/250	64	200	-25..+65	2,1	p. 259 / A1)	
		(B) 1 ~ 115	60	840	2910	88	0,77	6,0/250	64	240	-25..+65	2,1		

Subject to alternations

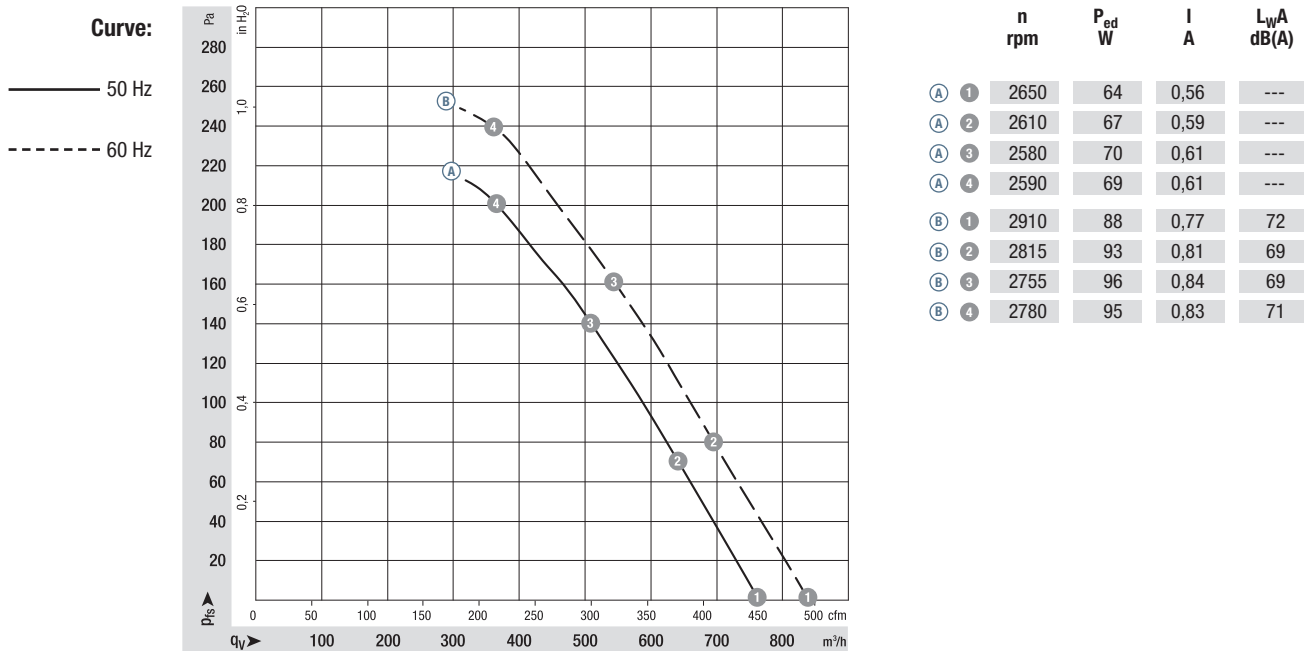

Air performance measured as per: ISO 5801, Installation category A, without protection against accidental contact. Suction-side noise levels: LWA as per ISO 13347, LpA measured at 1 m distance to fan axis. The acoustic values given are only valid under the measurement conditions listed and may vary depending on the installation situation. With any deviation to the standard setup, the specific values have to be checked and reviewed once installed or fitted! For detailed information see <http://www.ebmpapst.com/general conditions>

- **Motor protection:** TOP wired internally
- **Touch current:** < 0,75 mA acc. to IEC 60990 (test circuit, illustration 4)
- **Cable exit:** Lateral
- **Electrical connection:** Via connector
- **Protection class:** I (if customer has provided connection for protective earth)
- **Product conforming to standards:** EN 60335-1, CE
- **Approvals:** UL 2111, CSA C22.2 Nr. 77

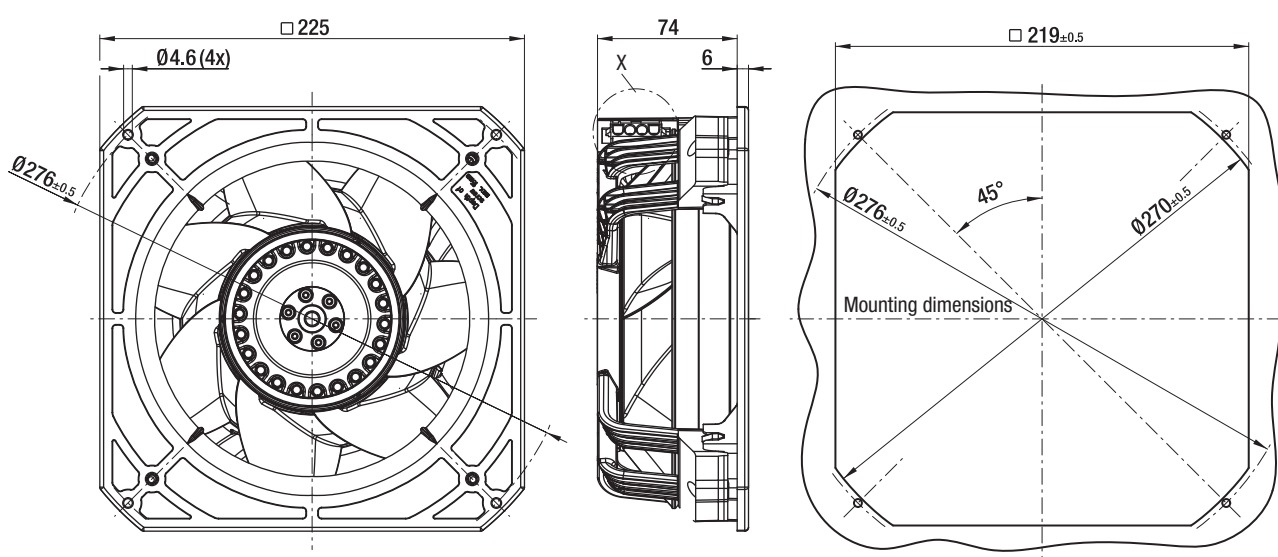

Coded plug system  
 Universal-Mate-N-Lok  
 Connector shell: AMP 350 780-1  
 3 x Pin connector: AMP 926 885-1  
 Mating connector (not part of  
 delivery):  
 Connector shell: AMP 350 779-4  
 3 x female terminal: AMP 926 884-1

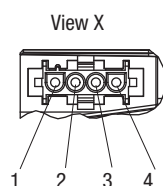

1 = not used  
 2 = N + condensator  
 3 = L  
 4 = PE

max. 850 m<sup>3</sup>/h

# AC diagonal module

Ø 200 mm



- **Material:** Housing: Plastic PA  
Support bracket: Plastic PA  
Impeller: Plastic PA  
Rotor: Coated in black
- **Number of blades:** 7
- **Direction of air flow:** "V"
- **Direction of rotation:** Clockwise, seen on rotor
- **Type of protection:** IP 44, depending on installation and position
- **Insulation class:** "F"
- **Mounting position:** Any
- **Condensate discharges:** None
- **Operation mode:** Continuous operation (S1)
- **Bearings:** Maintenance-free ball bearings

Nominal data		Curve	Nominal voltage	Frequency	Air flow	Speed / rpm	Input power	Input current	Capacitor	Sound pressure level	Max. back-pressure	Perm. amb. temp.	Mass	Electrical connection
Type	Motor		VAC	Hz	m <sup>3</sup> /h	rpm	W	A	µF/VDB	dB(A)	Pa	°C	kg	
K2E 200-AA52 -02	M2E 068-CF	Ⓐ 1	~ 230	50	765	2650	65	0,30	2,0/400	62	200	-25..+75	2,1	p. 259 / A1)
		Ⓑ 1	~ 230	60	850	2950	90	0,40	2,0/400	62	245	-25..+75	2,1	

Subject to alternations

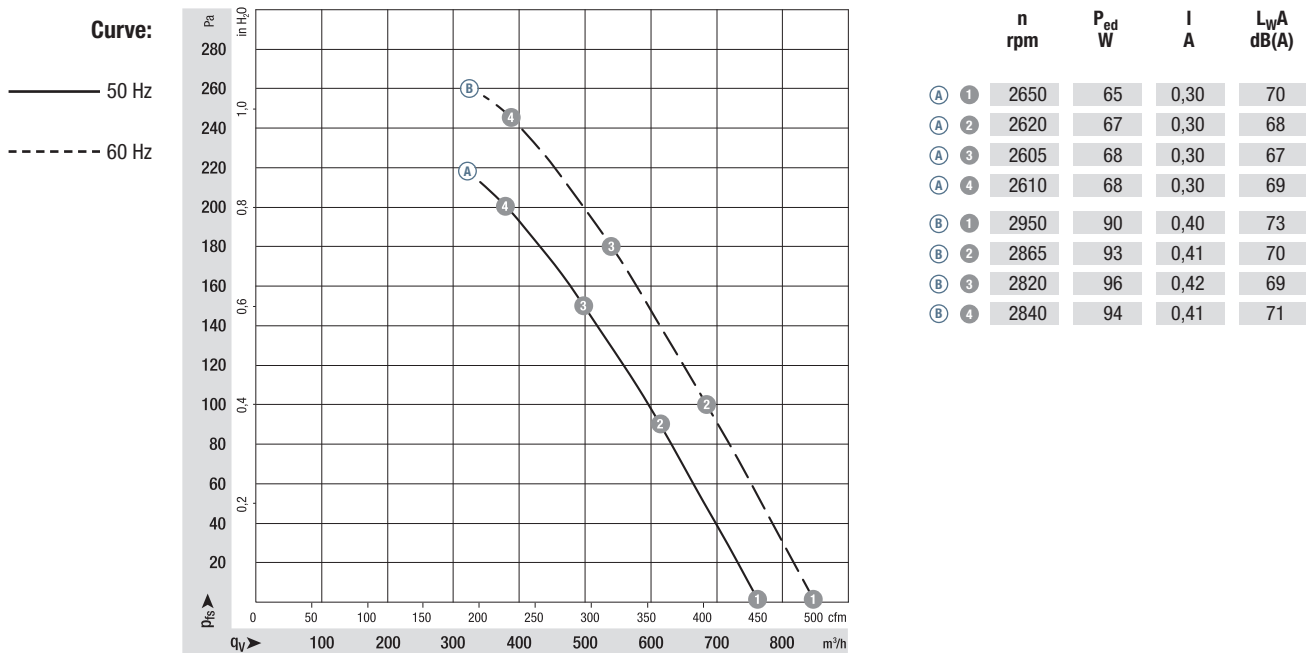

Air performance measured as per: ISO 5801, Installation category A, without protection against accidental contact. Suction-side noise levels: LWA as per ISO 13347, LpA measured at 1 m distance to fan axis. The acoustic values given are only valid under the measurement conditions listed and may vary depending on the installation situation. With any deviation to the standard setup, the specific values have to be checked and reviewed once installed or fitted! For detailed information see <http://www.ebmpapst.com/general conditions>

- **Motor protection:** TOP wired internally
- **Touch current:** < 0,75 mA acc. to IEC 60990 (test circuit, illustration 4)
- **Cable exit:** Lateral
- **Electrical connection:** Via connector
- **Protection class:** I (if customer has provided connection for protective earth)
- **Product conforming to standards:** EN 60335-1, CE
- **Approvals:** UL 2111, CSA C22.2 Nr. 77

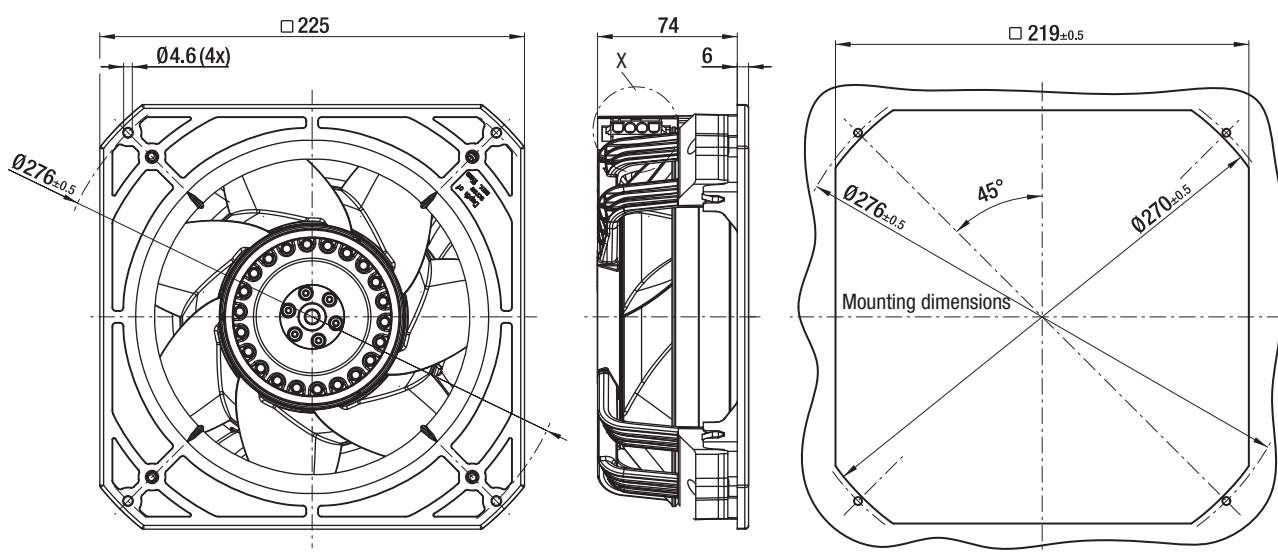

Coded plug system  
 Universal-Mate-N-Lok  
 Connector shell: AMP 350 780-1  
 3 x Pin connector: AMP 926 885-1  
 Mating connector (not part of  
 delivery):  
 Connector shell: AMP 350 779-4  
 3 x female terminal: AMP 926 884-1

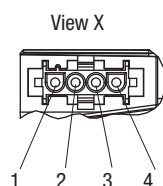

1 = not used  
 2 = N + condensator  
 3 = L  
 4 = PE



max. 880 m<sup>3</sup>/h

# AC diagonal module

Ø 200 mm



- **Material:** Housing: Plastic PA  
Support bracket: Plastic PA  
Impeller: Plastic PA  
Rotor: Coated in black
- **Number of blades:** 7
- **Direction of air flow:** "V"
- **Direction of rotation:** Clockwise, seen on rotor
- **Type of protection:** IP 44, depending on installation and position
- **Insulation class:** "F"
- **Mounting position:** Any
- **Condensate discharges:** None
- **Operation mode:** Continuous operation (S1)
- **Bearings:** Maintenance-free ball bearings

Nominal data		Curve	Nominal voltage	Frequency	Air flow	Speed / rpm	Input power	Input current	Capacitor	Sound pressure level	Max. back-pressure	Perm. amb. temp.	Mass	Electrical connection
Type	Motor		VAC	Hz	m <sup>3</sup> /h	rpm	W	A	µF/VDB	dB(A)	Pa	°C	kg	
<b>K2D 200-AA02 -02</b>	M2D 068-CF	(A)	3~ 400 Y	50	780	2700	65	0,15	---	62	210	-25..+75	2,0	p. 259 / C2)
		(B)	3~ 400 Y	60	880	3050	90	0,16	---	65	260	-25..+75	2,0	

Subject to alternations

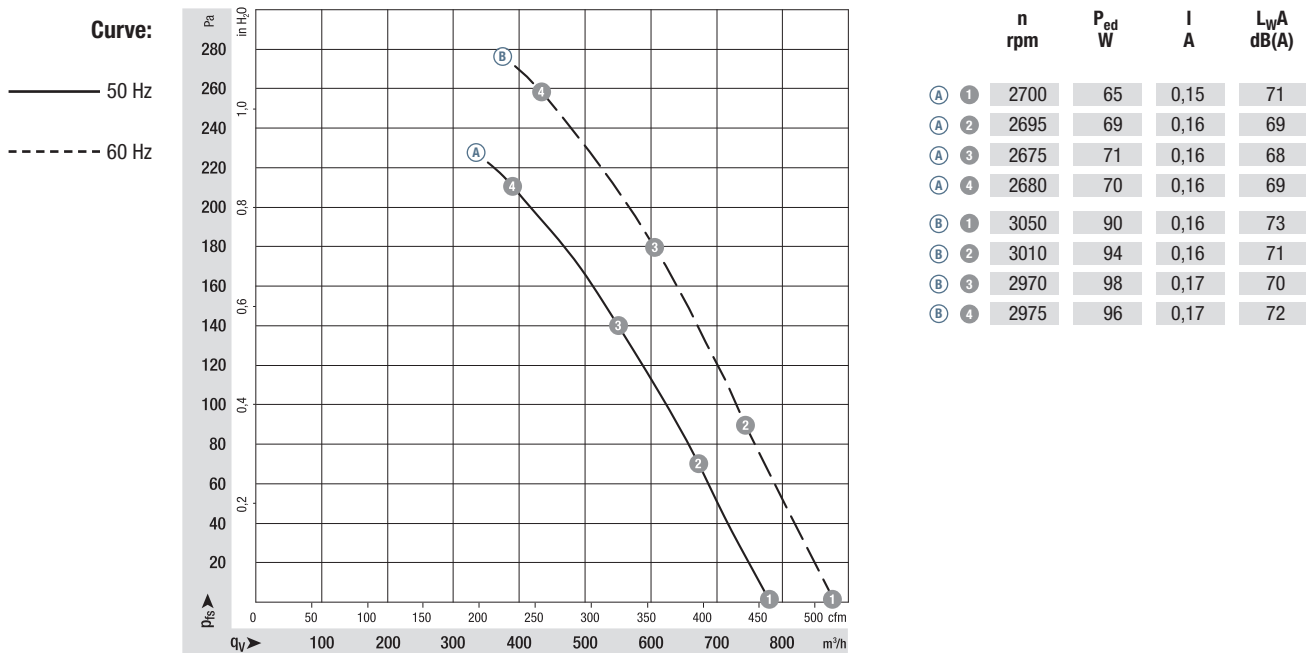

Air performance measured as per: ISO 5801, Installation category A, without protection against accidental contact. Suction-side noise levels: LWA as per ISO 13347, LpA measured at 1 m distance to fan axis. The acoustic values given are only valid under the measurement conditions listed and may vary depending on the installation situation. With any deviation to the standard setup, the specific values have to be checked and reviewed once installed or fitted! For detailed information see <http://www.ebmpapst.com/general conditions>

- **Motor protection:** TOP wired internally
- **Touch current:** < 0,75 mA acc. to IEC 60990 (test circuit, illustration 4)
- **Cable exit:** Lateral
- **Electrical connection:** Via connector
- **Protection class:** I (if customer has provided connection for protective earth)
- **Product conforming to standards:** EN 60335-1, CE

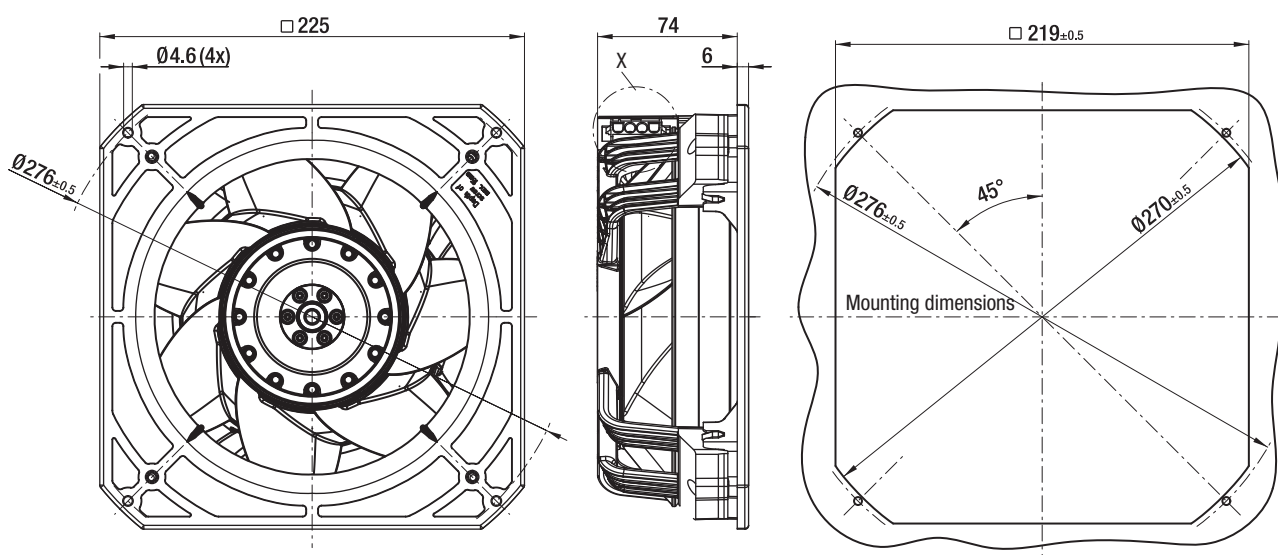

Coded plug system  
 Universal-Mate-N-Lok  
 Connector shell: AMP 350 780-1  
 3 x Pin connector: AMP 926 885-1  
 Mating connector (not part of  
 delivery):  
 Connector shell: AMP 350 779-4  
 3 x female terminal: AMP 926 884-1

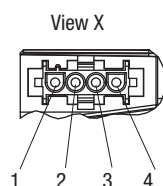

1 = L3  
 2 = L1  
 3 = L2  
 4 = PE



# AC centrifugal fans



AC centrifugal fan overview

229

AC centrifugal fans

230

# AC centrifugal fans

## Technical information

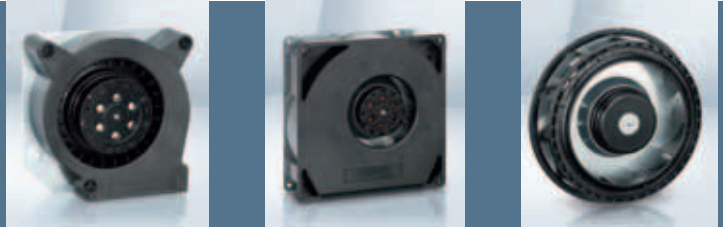

### Product line

The renowned ebm-papst AC fans are used when DC voltage is not available. The AC range of fans is based on experience gained from decades of development activity, millions of units in series production and competence in innovation of a world-wide technological leader.

A wide range of fans for AC operation is presented in this catalogue. In addition to complete device fans, you will also find fans without external housing, providing a particularly economical advantage when the air duct can be integrated in the respective device.

### Variety of sizes

AC fans are available in a variety of sizes with either air exhaust or air intake over struts. Silent running models with sleeve bearings (or for extreme ambient conditions) fans with ball bearings are available. Electrical connection with plug connection or external leads are available.

### Shaded-pole or capacitor motors

Fan drives by shaded-pole or capacitor motors, most of which incorporate the world-famous ebm-papst external rotor principle: The fan blades are directly attached to the external rotor of the external rotor motor, thus combining both high performance and profitability.

### Flat built AC fans

ebm-papst also has particularly flat built AC fans with internal rotor motor. Their advantage: quick start to full speed. A plastic impeller and the both smaller and lighter internal rotor motor lead to a lower moment of inertia.

### Bearings

AC fans with sleeve bearings are powered by Class E insulated motors. Fans with ball bearings are equipped with Class B, E or F insulated motors.

### Type of protection

All ebm-papst fans conform to the requirements of IP 20. Fans conforming to IP 54 / IP 68 and special types of protection are also available.

### AC voltage

The line of AC fans for Euro voltage according to IEC 60038 (230 V  $\pm$  10 %) is basically also available for 115 V.

### Frequencies

AC fans can be operated at frequencies of 50 Hz or 60 Hz. However, their technical data then change accordingly.

### Capacitor

Fans driven by capacitor external motors provide particularly high operating efficiency. Generally, the required operating capacitor is already integrated in the fan housing.

### Overloading

Almost all AC fans are protected against overloading (e.g. due to locked rotor) the drive motors are either impedance protected (marked "Impedance protected", and/or "Z.P.") or are equipped with a thermal switch (marked "Thermally protected" or "Th.P."). The model designation of these fans ends with "S".

# Centrifugal fans for AC operation

## Overview of air performance

Dimension	Series	Air flow	Page
mm		m <sup>3</sup> /h	
		10 20 30 40 50 60 70 80 90 100 200 300 400 500 600 700 800 900 1000 2000 3000	
□ 121 x 37	RL 90	40...42	230
□ 135 x 38	RG 90	47...54	231
□ 180 x 40	RG 125	86...94	232
□ 220 x 56	RG 160	202...223	233
∅ 138 x 40	RER 125	104...115	234
∅ 176 x 54	RER 160	234...274	235

Subject to alternations

## Overview of technically feasible designs

Dimension	VDE, UL, CSA	Shields, sleeve bearings/ Ball bearings	Speed signal	Humidity protection IP >= IP 54	IP >= IP 68	Salt fog protection	Page
<b>Centrifugal fans</b>							
<b>Series</b>	<b>mm</b>		<b>OPTIONAL</b>				<b>p.</b>
RL 90	121 x 121 x 37	ja □/■	-	• • - •	- •	- •	230
RG 90	135 x 135 x 38	ja □/■	-	• • - •	- •	- •	231
RG 125	180 x 180 x 40	ja ■	-	• • - •	- •	- •	232
RG 160	220 x 220 x 56	ja ■	-	• • - •	- •	- •	233
RER 125	138 ∅ x 40	ja ■	-	• • - •	- •	- •	234
RER 160	176 ∅ x 54	ja ■	-	• • - •	- •	- •	235
Subject to alternations							
<ul style="list-style-type: none"> <li>• available   - not yet available   □ Sleeve bearings   ■ Ball bearings</li> </ul>							

max. 42 m<sup>3</sup>/h

# AC centrifugal fans

Series RL 90 121 x 121 x 37 mm



- **Material:** Spiral housing: GRP<sup>1)</sup> (PBT)  
Impeller: GRP<sup>1)</sup> (PA)  
Housing base: Steel plate
- **Direction of air flow:** Centrifugal: Air outlet via window in housing
- **Direction of rotation:** Clockwise, seen on rotor
- **Connection:** Via 2 single wires; housing base with flat plugs  
6,3 x 0,8 mm for protective earth conductor
- **Highlights:** forwards-curved impeller
- **Mass:** 680 g

- **Possible special versions:**  
(See page 12)
  - Protection against moisture
  - Protection against salt fog
  - Type of protection: IP 54

1) Fibreglass-reinforced plastic

Nominal data	Air flow		Nominal voltage	Frequency	Sound power level	Sinter sleeve bearings		Input power	Nominal speed	Temperature range	Service life L <sub>10</sub>		Curve
	m <sup>3</sup> /h	CFM				Ball bearings	Hours				at T <sub>max</sub>		
Type	m <sup>3</sup> /h	CFM	V	Hz	Bel(A)	□/■	Watts	rpm	°C	Hours	Hours		
RL 90-18/50	40	23,5	230	50	5,6	□/■	20,0	2 450	-10...+50	37 500 / 30 000		①	
RL 90-18/56	40	23,5	230	50	5,6	/■	20,0	2 450	-30...+70	37 500 / 20 000		①	
RL 90-18/00	42	24,7	115	60	6,0	□/■	19,5	2 550	-10...+60	37 500 / 25 000		②	
RL 90-18/06	42	24,7	115	60	6,0	/■	19,5	2 550	-30...+85	37 500 / 15 000		②	

Subject to alternations

Fan type		Lead wires
RL 90-18/50	RL 90-18/00	AWG 18, TR 32
RL 90-18/56	RL 90-18/06	AWG 22

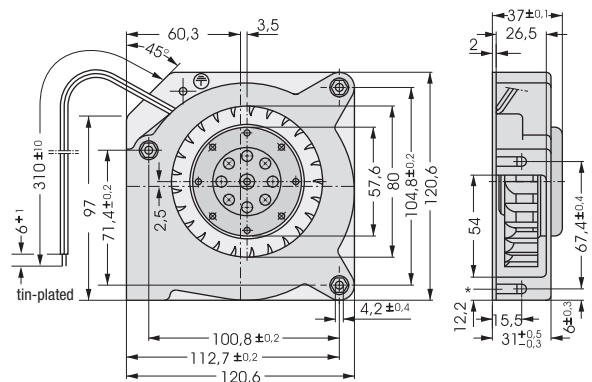
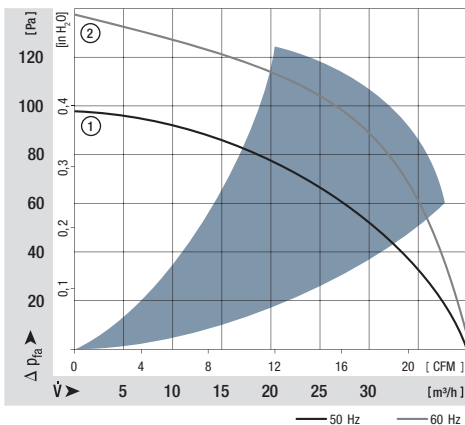

\*Speed nut M4 or 8-32UNC. Screw- in depth max.12,5 min 9,0



max. 54 m<sup>3</sup>/h

# AC centrifugal fans

Series RG 90 135 x 135 x 38 mm

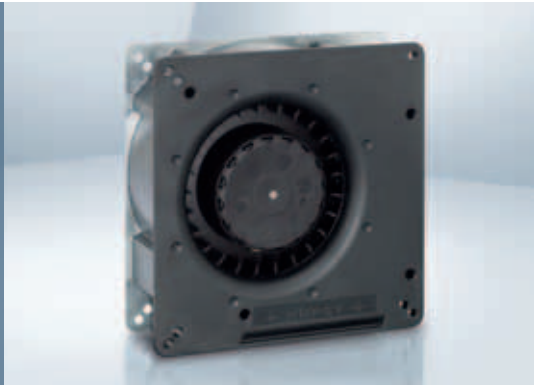

- **Material:** Spiral housing: GRP<sup>1)</sup> (PBT)  
Impeller: GRP<sup>1)</sup> (PA)  
Housing base: Steel plate
  - **Direction of air flow:** Centrifugal: Air outlet via window in housing
  - **Direction of rotation:** Clockwise, seen on rotor
  - **Connection:** Via 2 single wires AWG 22
  - **Highlights:** forwards-curved impeller
  - **Mass:** 560 g
- **Possible special versions:** (See page 12)
    - Protection against moisture
    - Protection against salt fog
    - Type of protection: IP 54

1) Fibreglass-reinforced plastic

Nominal data	Air flow		Nominal voltage	Frequency	Sound power level	Sinter sleeve bearings		Input power	Nominal speed	Temperature range	Service life L <sub>10</sub>		Curve
	m <sup>3</sup> /h	CFM				Ball bearings	Watts				Hours	at T <sub>max</sub>	
Type	m <sup>3</sup> /h	CFM	V	Hz	Bel(A)	□/■	Watts	rpm	°C	Hours	Hours		
RG 90-18/50	54	32	230	50	5,8	□/■	22,0	2 200	-30...+60	35 000 / 22 500		①	
RG 90-18/56	54	32	230	50	5,8	/■	22,0	2 200	-30...+60	35 000 / 22 500		①	
RG 90-18/00	47	28	115	60	6,2	□/■	22,0	1 900	-30...+65	35 000 / 20 000		②	
RG 90-18/06	47	28	115	60	6,2	/■	22,0	1 900	-30...+65	35 000 / 20 000		②	

Subject to alternations

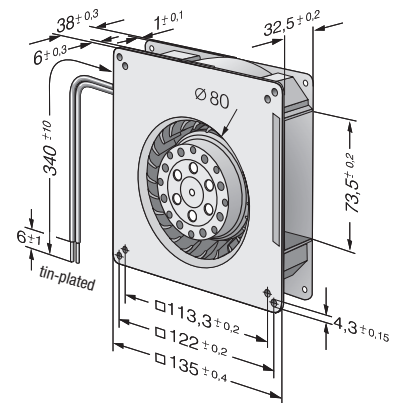
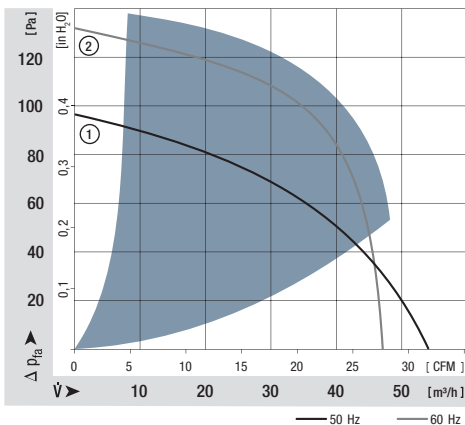

max. 94 m<sup>3</sup>/h

# AC centrifugal fans

Series RG 125 180 x 180 x 40 mm

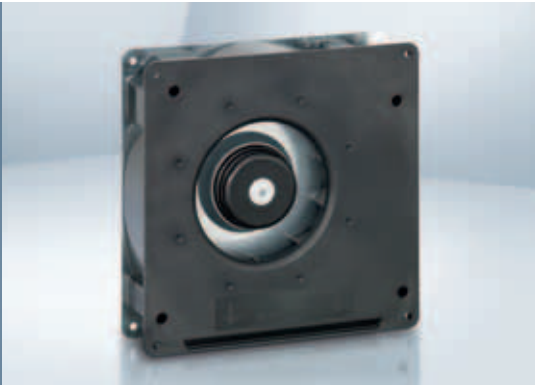

- **Material:** Spiral housing: GRP<sup>1)</sup> (PBT)  
Impeller: GRP<sup>1)</sup> (PA)  
Housing base: Steel plate
  - **Direction of air flow:** Centrifugal: Air outlet via window in housing
  - **Direction of rotation:** Clockwise, seen on rotor
  - **Connection:** Via 2 single wires AWG 22
  - **Highlights:** backwards-curved impeller
  - **Mass:** 850 g
- **Possible special versions:**  
(See page 12)
    - Protection against moisture
    - Protection against salt fog
    - Type of protection: IP 54

1) Fibreglass-reinforced plastic

Nominal data	Air flow		Nominal voltage	Frequency	Sound power level	Sinter sleeve bearings		Input power	Nominal speed	Temperature range	Service life L <sub>10</sub>		Curve
	m <sup>3</sup> /h	CFM				Ball bearings	Watts				Hours	at T <sub>max</sub>	
Type	m <sup>3</sup> /h	CFM	V	Hz	Bel(A)	□/■	Watts	rpm	°C	Hours	Hours		
RG 125-19/56	86	51	230	50	5,8	/■	20,0	2 550	-30...+70	37 500 / 20 000		①	
RG 125-19/06	94	55	115	60	6,0	/■	19,0	2 750	-30...+80	40 000 / 15 000		②	

Subject to alternations

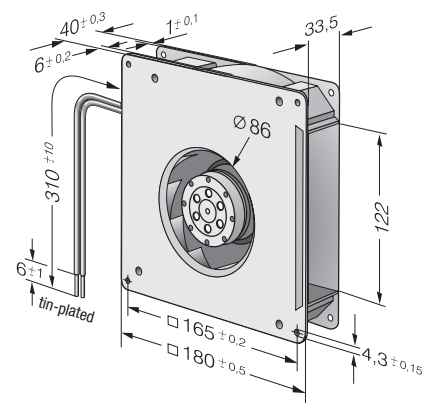
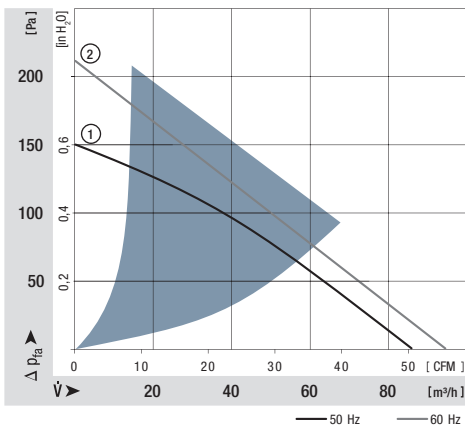

max. 223 m<sup>3</sup>/h

# AC centrifugal fans

Series RG 160 220 x 220 x 56 mm



- **Material:** Spiral housing: GRP<sup>1)</sup> (PBT)  
Impeller: GRP<sup>1)</sup> (PA)  
Housing base: Steel plate
  - **Direction of air flow:** Centrifugal: Air outlet via window in housing
  - **Direction of rotation:** Counter-clockwise, seen on rotor
  - **Connection:** Via 2 single wires AWG 18
  - **Highlights:** backwards-curved impeller
  - **Mass:** 1,7 kg
- **Possible special versions:**  
(See page 12)  
- Protection against moisture

1) Fibreglass-reinforced plastic

Nominal data	Air flow		Nominal voltage	Frequency	Sound power level	Sinter sleeve bearings		Input power	Nominal speed	Temperature range	Service life L <sub>10</sub>		Curve
	m <sup>3</sup> /h	CFM				Ball bearings	Watts				Hours	at T <sub>max</sub>	
Type	m <sup>3</sup> /h	CFM	V	Hz	Bel(A)	□/■	Watts	rpm	°C	Hours	Hours	Curve	
RG 160-28/56S	202	119	230	50	6,6	/■	47,0	2 750	-30...+70	30 000 / 15 000		①	
RG 160-28/06S	223	131	115	60	6,9	/■	50,0	3 050	-30...+80	27 500 / 12 500		②	

Subject to alternations

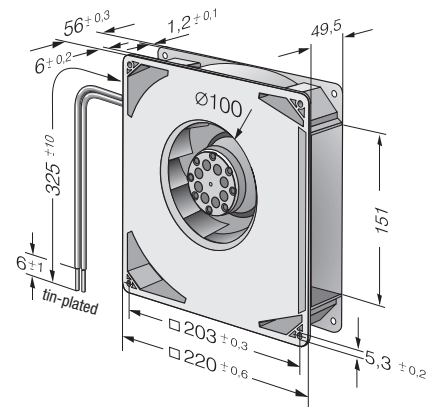
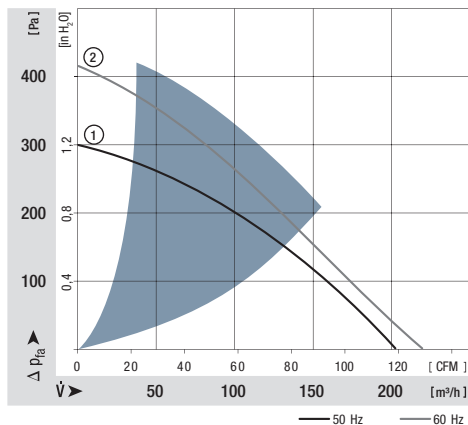

max. 115 m<sup>3</sup>/h

# AC centrifugal fans

Series RER 125 138 Ø x 40 mm



- **Material:** Spiral housing: GRP<sup>1)</sup> (PBT)  
Impeller: GRP<sup>1)</sup> (PA)  
with steel plate reinforced
  - **Direction of air flow:** centrifugal
  - **Direction of rotation:** Clockwise, seen on rotor
  - **Connection:** Via 2 single wires AWG 22
  - **Highlights:** backwards-curved impeller
  - **Mass:** 500 g
- **Possible special versions:**  
(See page 12)
    - Protection against moisture
    - Protection against salt fog
    - Type of protection: IP 54

1) Fibreglass-reinforced plastic

Nominal data	Air flow		Nominal voltage	Frequency	Sound power level	Sinter sleeve bearings Ball bearings	Input power	Nominal speed	Temperature range	Service life L <sub>10</sub>		Curve
	m <sup>3</sup> /h	CFM								Hours	Hours	
Type	m <sup>3</sup> /h	CFM	V	Hz	Bel(A)	□/■	Watts	rpm	°C	Hours	Hours	
RER 125-19/56	104	61	230	50	6,2	/■	19,0	2 600	-30...+60	37 500 / 22 500		①
RER 125-19/06	115	68	115	60	6,5	/■	18,0	2 850	-30...+70	40 000 / 20 000		②

Subject to alternations

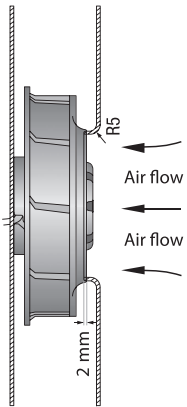

The air flow and noise level of fans without external housing depend on the installation conditions. The stated air flow and noise levels have been measured under the following conditions:  
Centrifugal fan mounted on a base plate 220 x 220 mm.  
Cover plate 220 x 220 mm with an air inlet of Ø 86 mm, concentric to the impeller.

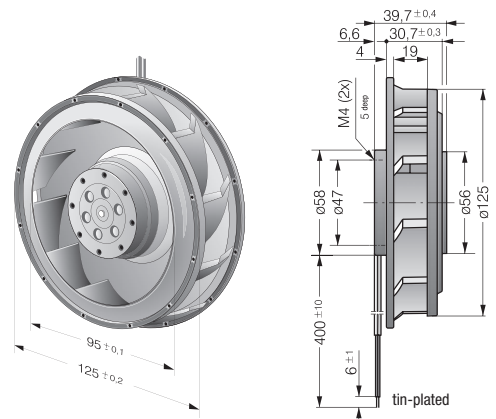
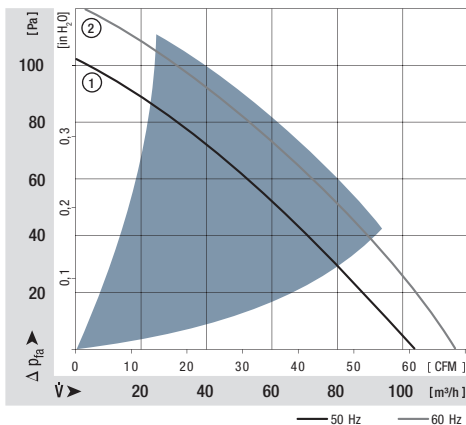

max. 274 m<sup>3</sup>/h

# AC centrifugal fans

Series RER 160 176 Ø x 54 mm



- **Material:** Spiral housing: GRP<sup>1)</sup> (PBT)  
Impeller: GRP<sup>1)</sup> (PA)  
with steel plate reinforced
  - **Direction of air flow:** centrifugal
  - **Direction of rotation:** Counter-clockwise, seen on rotor
  - **Connection:** Via 2 single wires AWG 18
  - **Highlights:** backwards-curved impeller
  - **Mass:** 1,0 kg
- **Possible special versions:**  
(See page 12)  
- Protection against moisture

1) Fibreglass-reinforced plastic

Nominal data	Air flow		Nominal voltage	Frequency	Sound power level	Sinter sleeve bearings Ball bearings	Input power	Nominal speed	Temperature range	Service life L <sub>10</sub>		Curve
	m <sup>3</sup> /h	CFM								at 40 °C	at T <sub>max</sub>	
Type	m <sup>3</sup> /h	CFM	V	Hz	Bel(A)	□/■	Watts	rpm	°C	Hours	Hours	
RER 160-28/56S	234	138	230	50	6,6	/■	45,0	2 800	-30...+60	30 000 / 20 000		①
RER 160-28/06S	274	161	115	60	6,8	/■	46,0	3 250	-30...+70	30 000 / 15 000		②

Subject to alternations

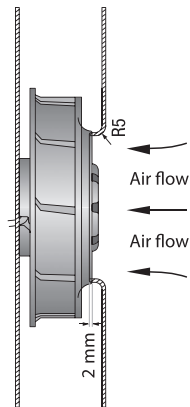

The air flow and noise level of fans without external housing depend on the installation conditions. The stated air flow and noise levels have been measured under the following conditions:  
Centrifugal fan mounted on a base plate 260 x 260 mm.  
Cover plate 260 x 260 mm with an air inlet of Ø 100 mm, concentric to the impeller.

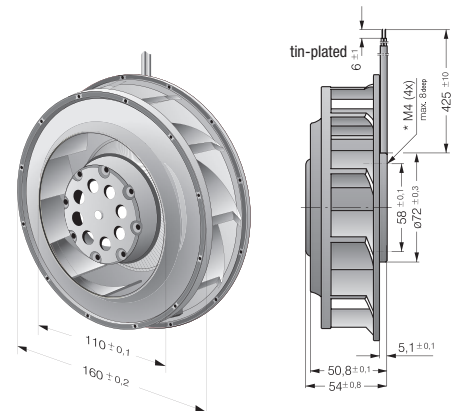
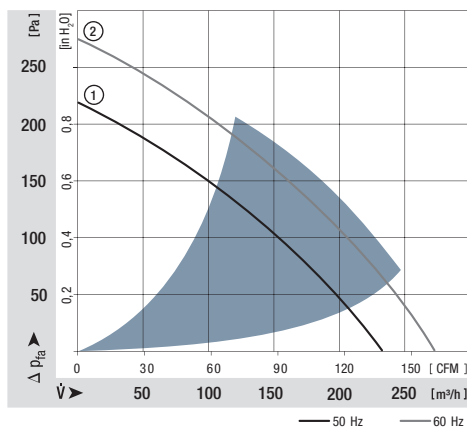



# Accessories

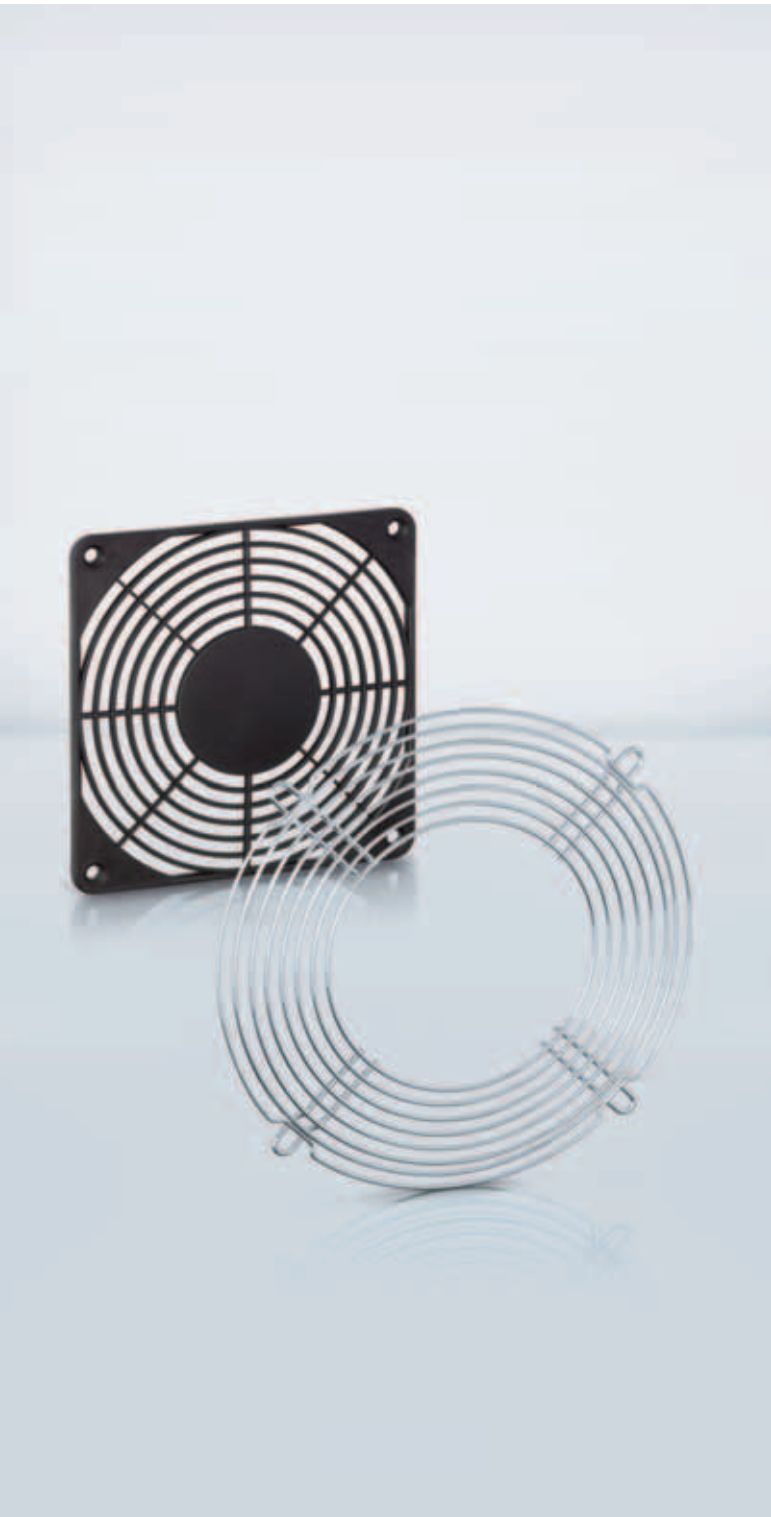

Guard grilles	238
Fan filter guard grilles	246
Inlet nozzles	248
Connection cables / Accessories	251
Electrical connections	254

Everything that you need for your fan. ebm-papst provides an extensive range of accessories for optimum fan operation: From temperature sensing for speed-controlled fans to finger guards of all types, connecting cable, filter, screens, spacers and assembly parts. In addition to the accessories and assembly parts listed in this catalogue, ebm-papst also supplies numerous special parts for fan operation. The sales experts at ebm-papst will be happy to assist you in your enquiries concerning fan assembly and application.

From selection to accessories: Insist on the efficient and reliable service provided by ebm-papst.



# Guard grilles



- **Material:** Zinc-plated or nickel-plated steel wire
- **Note:** Safety grille in line with DIN EN ISO 13857 (previously EN 294). Additional safety grilles that do not meet DIN EN ISO 13857 can be delivered on request. Our safety grilles are designed specifically for use with ebm-papst fans. They combine the highest degree of safety with minimum effect on operating noise. Please note that safety-relevant clearances cannot be guaranteed when using safety grilles from other manufacturers.

Fan series	Guard grilles
400	LZ29-1
420 J	LZ29-1
500	LZ31
600	LZ28-1
3000	LZ23-1
8000	LZ32-4 / LZ22-2
9000	LZ30-4 / LZ 30 / LZ 30-3
4000	LZ30-4 / LZ 30 / LZ 30-3

Fan series	Guard grilles
5100	LZ25
5600	LZ25
5200	LZ35
5300	LZ53
5900	LZ35
7000	LZ36
6300	LZ37
6400	LZ38

Fan series	Guard grilles
2200 F	LZ22
DV 4100	LZ30-4 Intake-/Outlet side
DV 5200	LZ35 Intake-/Outlet side
DV 6300	LZ37 Intake side
DV 6300	LZ52 Outlet side
DV 6400	LZ38 Intake side
DV 6400	LZ39 Outlet side

Subject to alternations

LZ29-1

Fan size 40 x 40

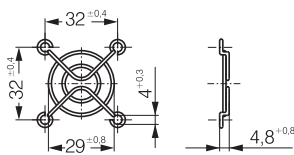

LZ31

Fan size 50 x 50

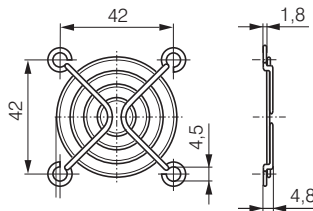

LZ28-1

Fan size 60 x 60

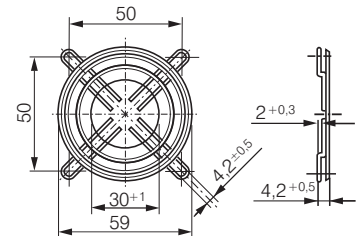

LZ22-2

Fan size 80 x 80

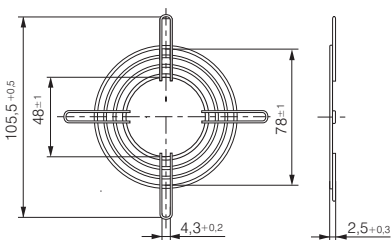

LZ32-4

Fan size 80 x 80

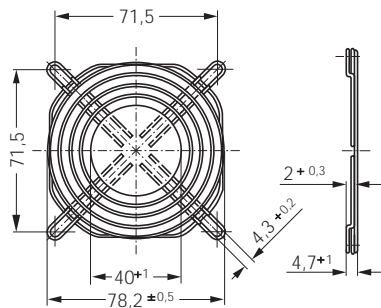

LZ23-1

Fan size 92 x 92

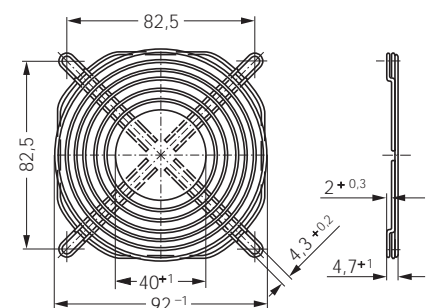

**LZ30** Fan size 119 x 119

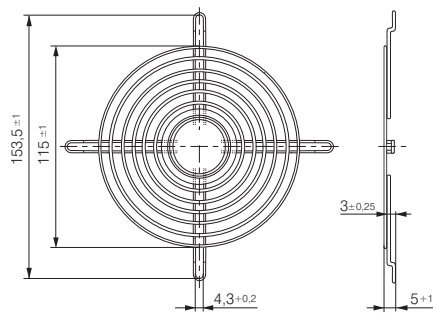

**LZ30-3** Fan size 119 x 119

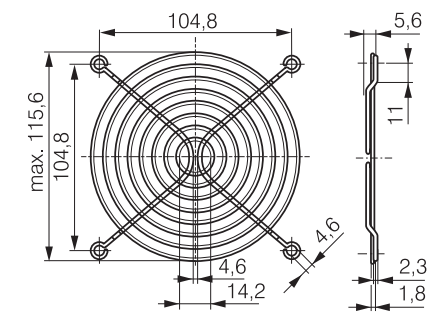

**LZ30-4** Fan size 119 x 119

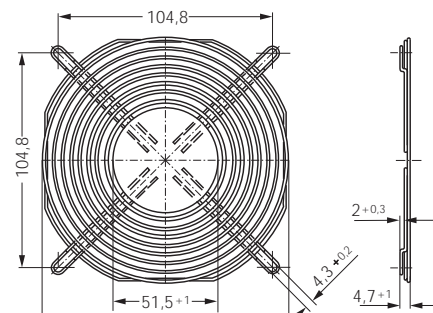

**LZ35** Fan size 127 x 127

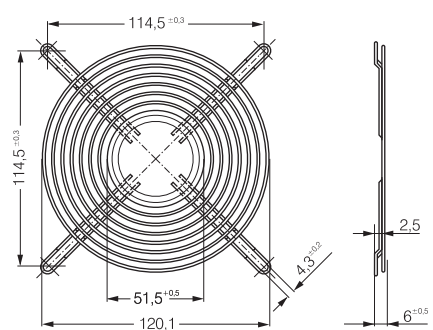

**LZ25** Fan size 135 x 135

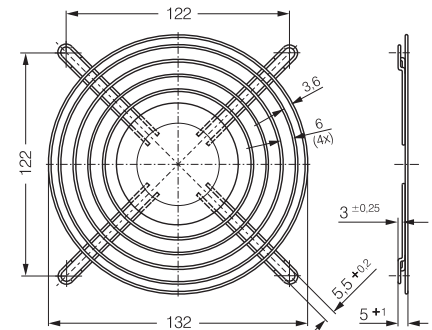

**LZ53** Fan size 140 x 140

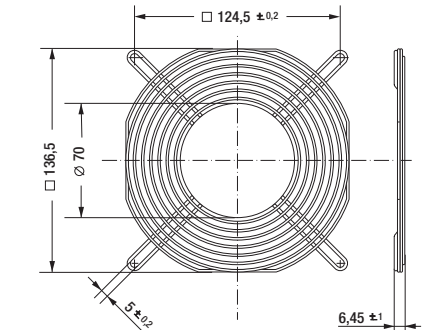

**LZ36** Fan size 150 x 172

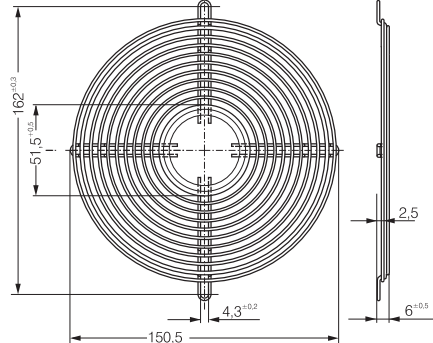

**LZ37** Fan size 172 x 51

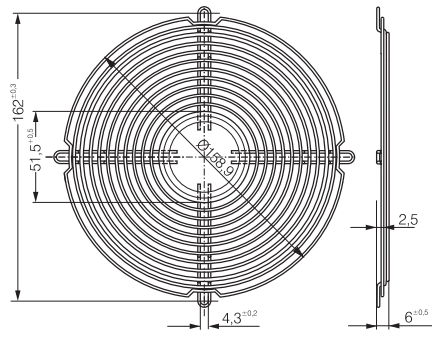

**LZ38** Fan size 172 x 51

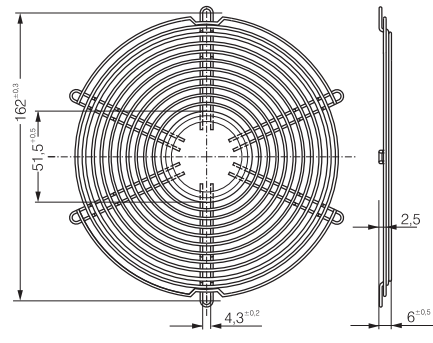

**LZ39** Fan size 172 x 51

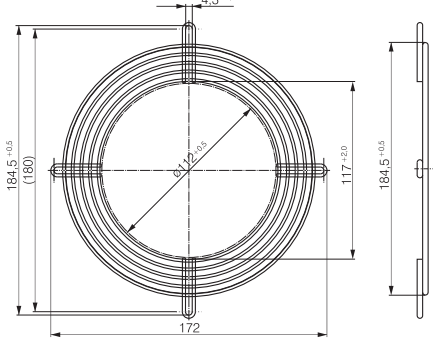

**LZ52** Fan size 172 x 51

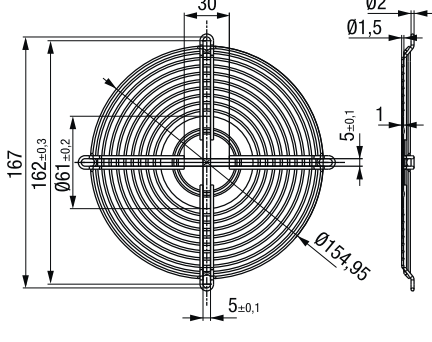

**LZ22** Fan size 200 x 51

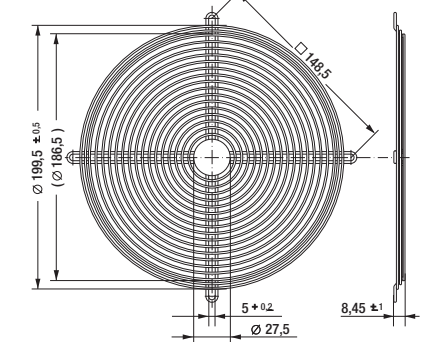

# Guard grilles

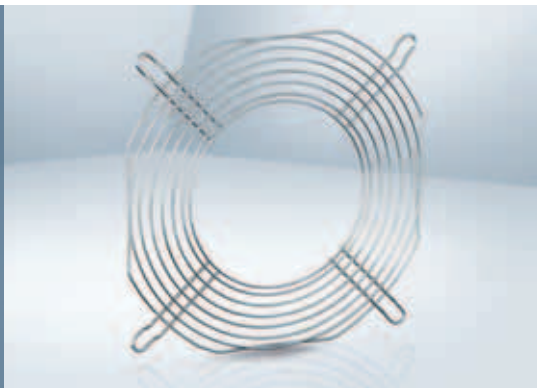

- **Material:** Zinc-plated or nickel-plated steel wire
- **Note:** Safety grille in line with DIN EN ISO 13857 (previously EN 294).  
The safety grilles detailed on this page are intended specifically for the ACmaxx / GreenTech EC compact fan ranges and are mounted on the pressure side.

Fan series	Guard grilles
AC 8300	LZ32-4 Intake side
AC 8300 H	LZ32-7 Outlet side
AC 3200 J	LZ23-1 Intake side
AC 3200 J	LZ23-6 Outlet side
AC 4400 FN	LZ30-4 Intake side
AC 4400 FN	LZ30-9 Outlet side
AC 4300	LZ30-4 Intake side
AC 4300	LZ30-9 Outlet side

Fan series	Guard grilles
ACi 4400	LZ30 Intake side
ACi 4400	LZ30 Outlet side
AC 6200 N	LZ37 Intake side
AC 6200 N	LZ37-2 Outlet side
AC 6100 N	LZ37 Intake side
AC 6100 N	* Outlet side

\* Outlet-side grilles on request

LZ30-9 Fan size 119 X 119

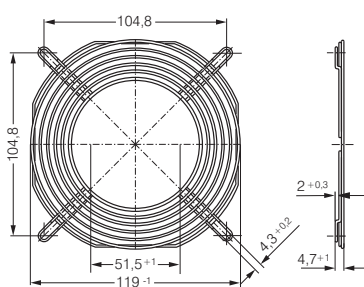

LZ37-2 Fan size Ø 172 X 51

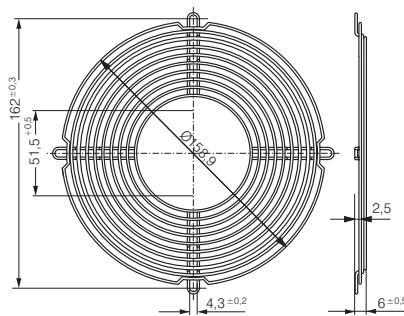

LZ23-6 Fan size 92 x 92

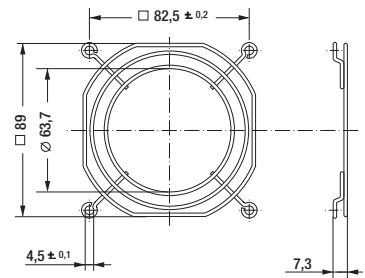

LZ32-7 Fan size 80 x 80

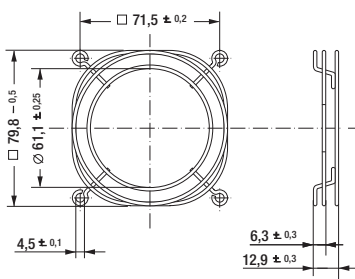

# Guard grilles

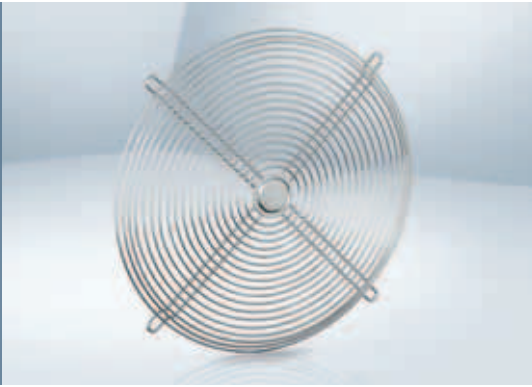

- **Material:** Steel wire, plastic-coated, silver-metallic gloss

Fan series	Guard grilles
W1G 200	78128-2-4039
W2E 200	78128-2-4039

Fan series	Guard grilles
W1G 250	09418-2-4039
W2E 250	09418-2-4039

78128-2-4039

Size 200

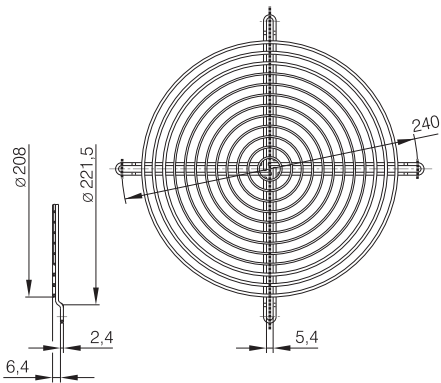

09418-2-4039

Size 250

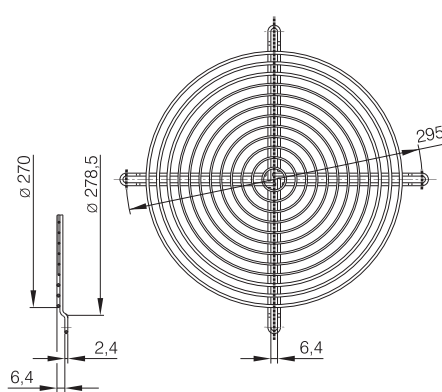

# Guard grilles

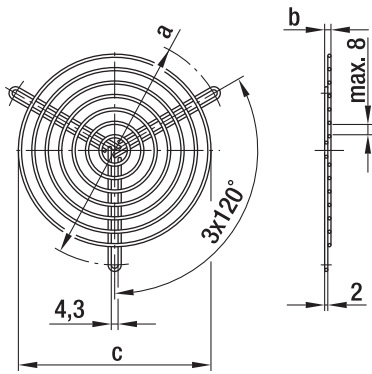

– **Material:** Steel wire

## Guard grilles for centrifugal blowers with dual inlet

Part no.	Size	a	b	c	Coating
83319-2-4039	097 <sup>(1)</sup>	96,0	3,5	71,0	phosphated, plastic-coated in RAL no. 9005
09485-2-4039	097 <sup>(2)</sup>	114,0	3,5	88,0	phosphated, plastic-coated in RAL no. 9005
09500-2-4039	133 / 146	145,0	4,0	122,0	phosphated, plastic-coated in RAL no. 9005

Subject to alternations

(1) for D2E097-CH

(2) for D2E097-B\*

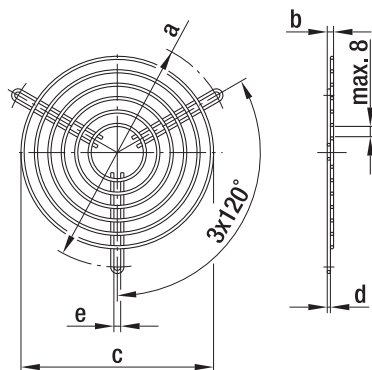

– **Material:** Phosphated steel wire, plastic-coated, silver-metallic gloss

## Guard grilles for centrifugal blowers with dual inlet (versions with EW motor)

Part no.	Size	a	b	c	d	e
35000-2-4039	160	182,0	12,0	144,0	2,4	4,5

Subject to alternations

# Guard grilles

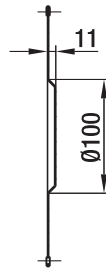
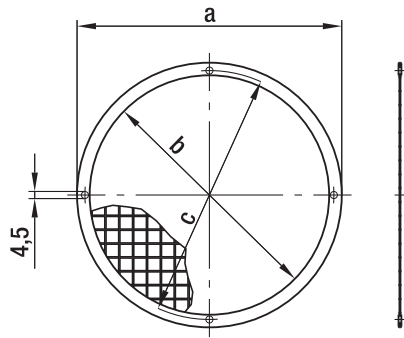

<sup>(4)</sup>Size 160

- **Material:** Welded grille made of galvanised steel, frame made of tinned sheet iron 0.4 mm thick

## Guard grilles for centrifugal blowers with single inlet

Part no.	Size	a	b	c
09489-2-4039	085 <sup>(3)</sup>	90,0	74,0	84,0
09490-2-4039	108	126,0	110,0	118,0
09494-2-4039	120	140,0	124,0	132,0
09492-2-4039	140 / 146	168,0	152,0	158,0
09503-2-4039	160 <sup>(4)</sup>	183,0	170,0	175,0

Subject to alternations

<sup>(3)</sup> 3 drilled holes staggered by 120°

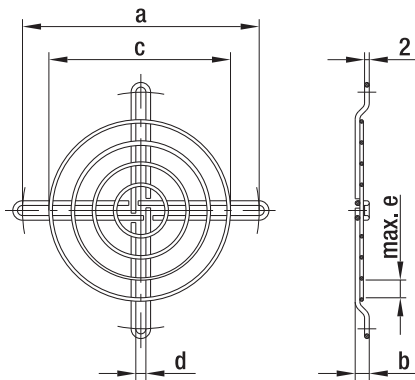

- **Material:** steel wire

## Guard grilles for centrifugal blowers with single inlet

Part no.	Size	a	b	c	d	e	Coating
09603-2-4039	076 / 085	101,0	6,0	79,0	4,3	8,0	plastic coated, silver-metallic gloss
98214-2-4039	108	120,0	3,5	88,0	4,3	8,0	plastic coated, silver-metallic gloss
25028-2-4039	140 / 146	162,0	8,5	139,0	4,3	8,0	galvanised, chromatised in blue
17729-2-4039	160	175,0	3,5	139,0	4,6	7,0	galvanised, chromatised in blue

Subject to alternations



# Guard grilles



- **Material:** Fibreglass-reinforced plastic
- **Note:** Guard grille acc. to DIN EN ISO 13857 (previously EN 294).  
Plastic grilles must not be used for the following models:  
8200 JH3 / JH4  
3200 JH3 / JH4  
4100 NH5 - NH8

Guard grilles	Mounting	B	C	D	E	Guard grilles	Mounting	B	C	D	E
LZ28-3	A3	60 <sup>-0.5</sup>	50,0 <sup>+0.2</sup>	3,0	24	LZ30-5	A2	119 <sup>-0.5</sup>	105 <sup>+0.2</sup>	6,5	50
LZ32-2	A1	80 <sup>-0.5</sup>	71,5 <sup>+0.2</sup>	7,0	34	LZ30-6	A4	119 <sup>-0.5</sup>	105 <sup>+0.2</sup>	6,5	50
LZ32-3	A3	80 <sup>-0.5</sup>	71,5 <sup>+0.2</sup>	7,0	34	LZ33-1	A2	127 <sup>-0.5</sup>	113,5 <sup>+0.2</sup>	6,5	50
LZ23-2	A1	92,5 <sup>-0.5</sup>	82,5 <sup>+0.2</sup>	6,5	46	LZ33-2	A4	127 <sup>-0.5</sup>	113,5 <sup>+0.2</sup>	6,5	50
LZ23-3	A3	92,5 <sup>-0.5</sup>	82,5 <sup>+0.2</sup>	6,5	46	Subject to alternations					

LZ28-3	Size 60 x 60
LZ32-2 / LZ32-3	Size 80 x 80
LZ23-2 / LZ23-3	Size 92 x 92
LZ30-5 / LZ30-6	Size 119 x 119
LZ33-1 / LZ33-2	Size 127 x 127

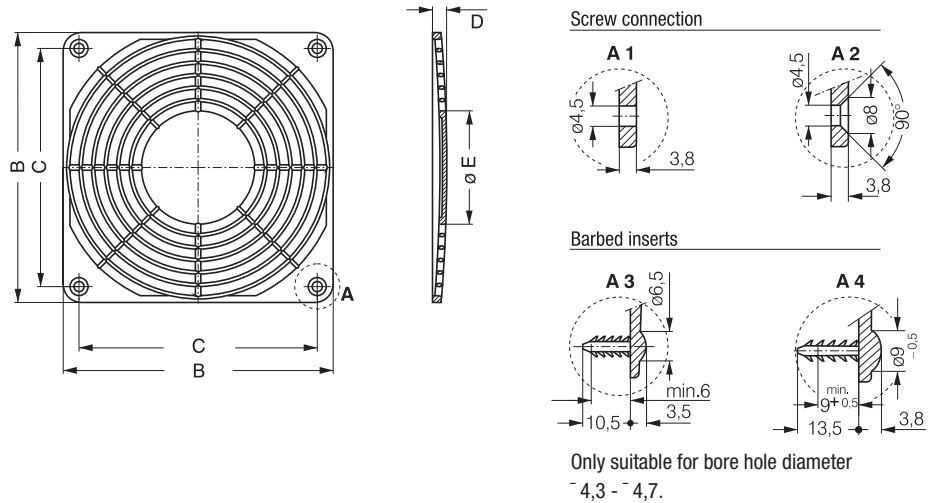

LZ28-3 Fan size 60 x 60

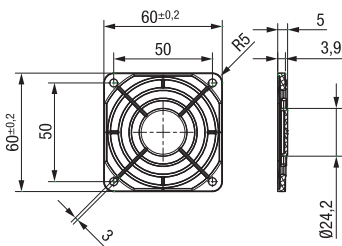

LZ32P Fan size 80 x 80

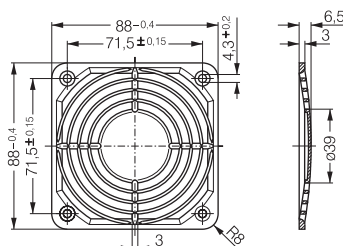

LZ30P Fan size 119 x 119

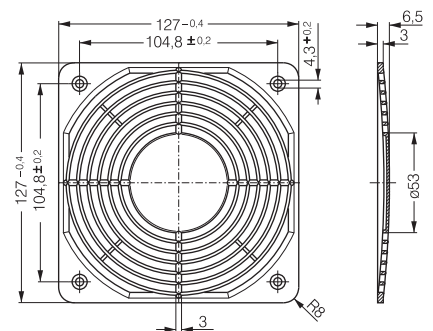



# Guard grilles

for compact centrifugal modules

- **Material:** Fibreglass-reinforced plastic PA
- **Highlights:** Flame protection class in line with UL 94V-0



Fan series	Guard grilles	a	b
RG 175/190	LZ46-1	133	9,0
RG 220	LZ47-1	166	8,7
RG 225	LZ48-1	158	8,7

Subject to alternations

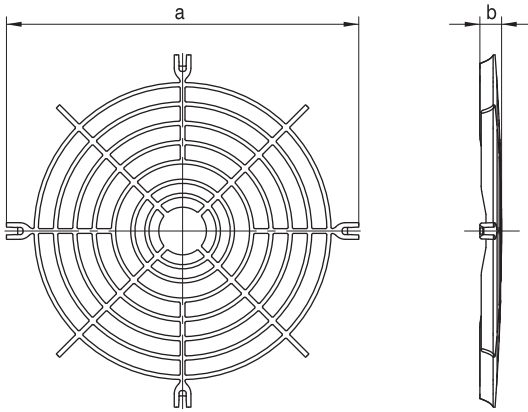

# Fan filter guard grilles

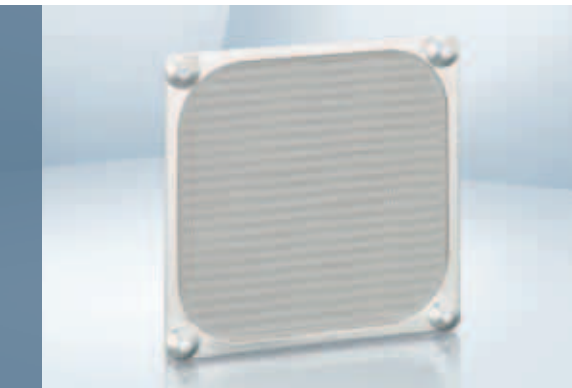

- **Material:** Filter guard LZ40 N: black, fibreglass-reinforced plastic with inserted wire mesh LZ60.  
Filter LZ60: stainless steel wire mesh  
Mounting lug LZ40-1 for mounting

Fan series DC	Fan series AC
4400 F	AC 4300
4400 FN	9900
4300	4000 N
4300 N	4000 Z
4400	Subject to alternations
4200	
4100 N	

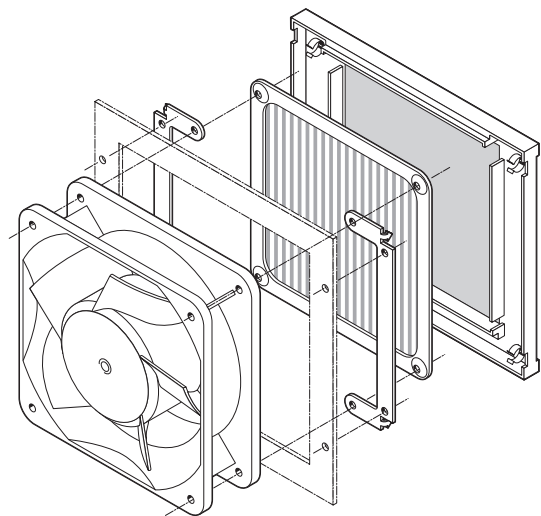

LZ40N Panel

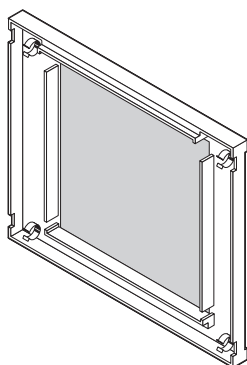

LZ40-1 Mounting lug

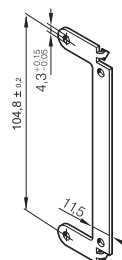
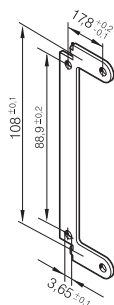

LZ60 Coarse filter

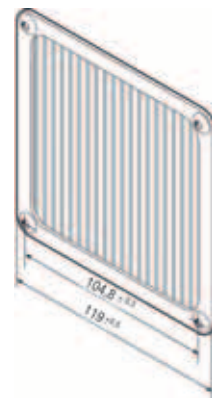

# Fan filter guard grilles



- **Material:** Grille cover: polycarbonate (PC) with matt finish  
Mounting plate: wire mesh with black powder coating  
Filter pad: white, synthetically joined fibres

- **Note:**

Filter safety grille suitable for fitting on axial fan ranges in the following dimensions: 60 mm, 80 mm, 92 mm, 119 mm,  $\varnothing$  172 mm. All filter units fit directly on the mounting holes on the fans.

Filter safety grille consisting of 3 parts: outer grille cover, inner mounting plate and replaceable filter pad.

The filter pad can be replaced quickly and easily via a quick release on the grille cover. The filter pads can be replaced even while the fan is running, as protection is provided by the welded wire mesh.

Protection filter	Fan size	A	B	C	D	Replacement filter*
FF60	60 x 60 mm	65	65	13,5	50,0	RF 60
FF80	80 x 80 mm	85	85	14,0	71,5	RF 80
FF92	92 x 92 mm	125	105	17,5	82,5	RF 92
FF119	119 x 119 mm	162	136	18,5	104,5	RF 119
FF172	$\varnothing$ 172 mm	226	190	19,5	162,0	RF 172

Subject to alternations

\* Replacement filters only in packs of 5 pcs.

## FF60 / FF80

Fan size: 60 x 60 mm  
80 x 80 mm

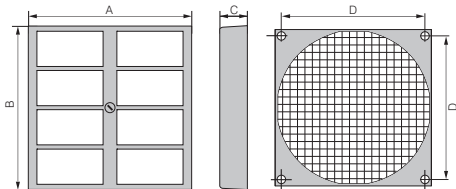

## FF92 / FF 119

Fan size: 92 x 92 mm  
119 x 119 mm

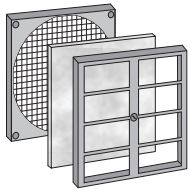
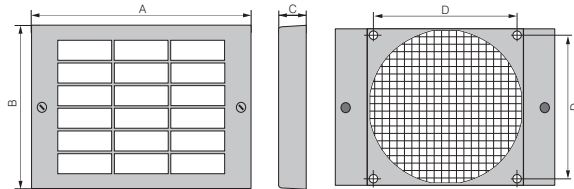

## FF 172

Fan size:  $\varnothing$  172 mm

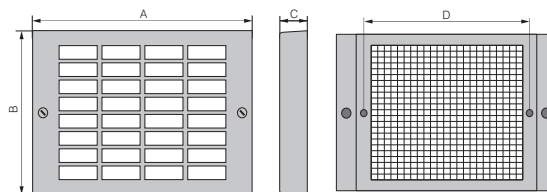

### Filter performance

The filter safety grille filters filter 75% of dust particles with a size of 5-10 microns and can withstand temperatures of up to 100 °C. Filter class G3 in line with DIN EN 779.

Flame-retardant in line with DIN 53438, class F1. With a clean mounted filter, a reduction of air flow of 20-30% is possible.

# Inlet nozzles

for centrifugal fans

– **Material:** Galvanised sheet steel

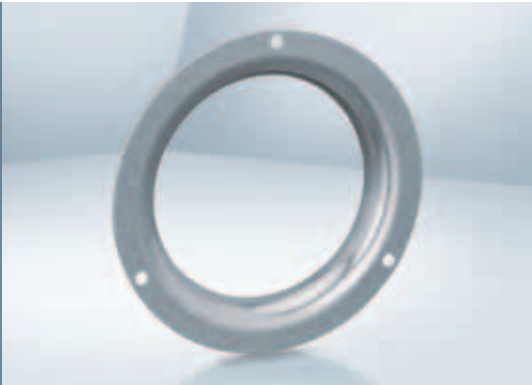

Fan	Vers.	k	m	o	q	r <sub>1</sub>	s	t	u	No.:	
RET 97	(S)	1	116,0	80,0	10,0	0,80	10,0	108,0	3x4,5	–	LZ 1000-097
RER 120	(P)	1	146,0	94,4	18,0	0,80	16,0	134,0	4x4,5	126,0	LZ 1000-120
RER 133	(P)	1	129,0	87,0	13,0	1,00	8,0	118,0	4x4,5	103,0	LZ 1000-133
RER 160	(S)	1	142,0	100,0	9,0	1,00	8,0	132,0	4x4,5	–	LZ 1000-160
RER 175 / 190	(P)	1	170,0	125,5	14,0	1,25	10,0	158,0	4x4,5	146,0	LZ 1000-175
RER 220	(P)	2	252,0	155,0	21,0	0,80	22,0	–	–	199,0	LZ 1000-220
RER 225	(P)	1	223,0	146,0	28,0	1,50	25,0	210,0	4x4,5	196,0	LZ 1000-225

(P) = plastic, (S) = sheet steel

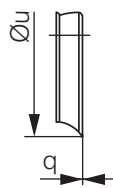
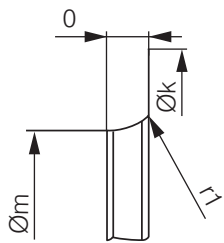

Vers. 1

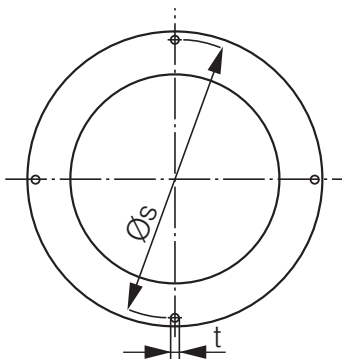

Vers. 2

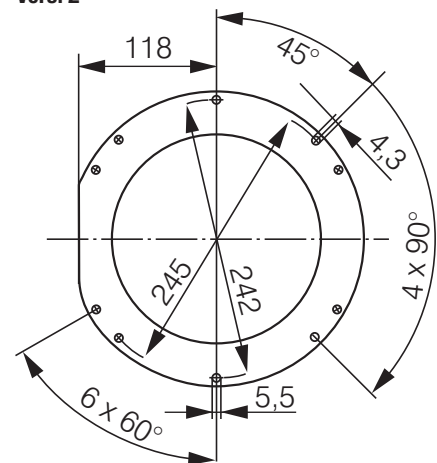

# Inlet nozzles for centrifugal fans

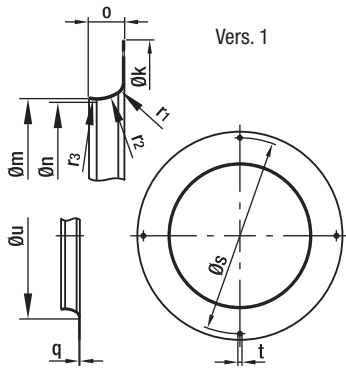

– **Material:** Galvanised sheet steel

## Inlet nozzles for backward curved centrifugal fans

Part no.	Size <sup>(1)</sup>	Vers.	k	m	n	o	q	r <sub>1</sub>	r <sub>2</sub>	r <sub>3</sub>	s	t	u
96120-2-4013	120 (P)	1	146,0	94,4	—	18,0	0,80	16,0	—	—	134,0	4x4,5	126,0

Subject to alternations

(1) Size with key for impeller material: (P) = plastic, (S) = sheet steel, (A) = aluminium

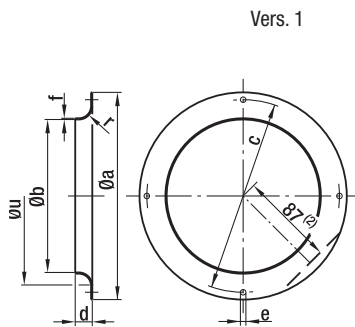

– **Material:** Galvanised sheet steel

## Inlet nozzles for forward curved centrifugal fans

Part no.	Size	Vers.	a	b	c	d	e	f	r	u
09560-2-4013	085 <sup>(1)</sup>	1	92,0	63,4	84,0	6,0	3x4,2	0,80	6,8	—
09563-2-4013	097 <sup>(1)</sup>	1	116,0	80,0	108,0	10,0	3x4,5	0,80	10,0	—
09566-2-4013	108	1	129,0	87,0	118,0	13,0	4x4,5	1,00	8,0	—
09569-2-4013	120	1	142,0	100,0	132,0	9,0	4x4,5	1,00	8,0	—
09572-2-4013	133	1	150,0	112,0	142,0	12,0	4x4,5	1,00	10,0	—
09576-2-4013	140 / 146	1	170,0	125,5	158,0	14,0	4x4,5	1,25	10,0	—
09588-2-4013	160	1 <sup>(2)</sup>	185,0	130,0	175,0	17,0	4x4,5	0,75	12,0	—

Subject to alternations

(1) 3 drilled holes staggered by 120°

(2) only for 09588-2-4013

# Inlet nozzles / Air filter

for centrifugal fans

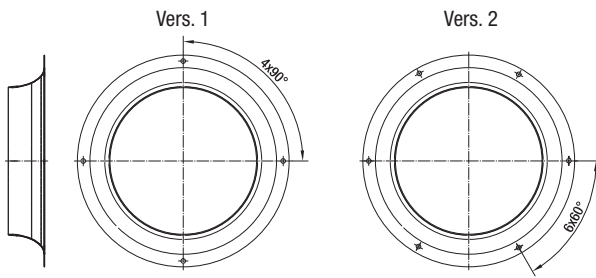

– **Material:** Galvanised sheet steel

## Inlet nozzles without measuring device for backward curved centrifugal fans

Part no.	Size	Vers.	Dimensions
09576-2-4013	190	1	see corresponding product page
09609-2-4013	220	2	see corresponding product page
96358-2-4013	225	1	see corresponding product page
96359-2-4013	250	1	see corresponding product page
28000-2-4013	280	1	see corresponding product page
31000-2-4013	310	1	see corresponding product page

Subject to alternations

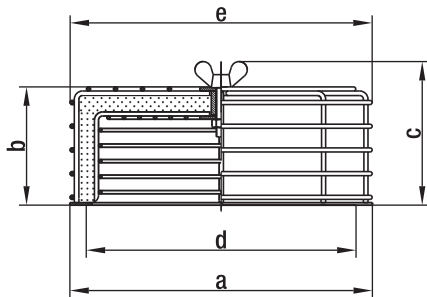

- **Material:** Steel wire / sheet steel plate, plastic coated in RAL no. 9005, black
- **Filter:** Viledon filter type R: PSB / 29 OS (according to DIN 24185)  
Separation capacity: < 86 %  
Efficiency: < 20 %  
Dust binding capacity: 650 g/m<sup>2</sup>

## Air filters for centrifugal blowers (with die-cast aluminium housing)

Part no.	Size	a	b	c	d	e	Spare filter
95777-1-5171	108 / 120	142,0	66,0	83,0	118-132	145,0	95779-1-5171
95778-1-5171	140 / 146 / 160	185,0	74,0	91,0	158-175	185,0	95780-1-5171

Subject to alternations

# Connection cables

- Connection cable with moulded plug connection in varying lengths.
- Wire end with core crimp sleeve, core-end sleeve or tin-plated.
- Straight or angled plug.
- For all fan types with pin 2.8 / 3.0 x 0.5.



Plug model	L1 (mm)	Leads	Plug	Leads end	Lead colour	Receptacle for tabs	Application
LZ120	610	0,5 mm <sup>2</sup>	G	C	black/black	2,8 x 0,5	AC
LZ120-4	2 000	0,5 mm <sup>2</sup>	G	A	black/black	2,8 x 0,5	AC
LZ120-5	380	0,5 mm <sup>2</sup>	W	B	red/black	2,8 x 0,5	DC
LZ120-6	610	0,5 mm <sup>2</sup>	W	B	red/black	2,8 x 0,5	DC
LZ120-11	2 000	0,5 mm <sup>2</sup>	G	A	red/black	2,8 x 0,5	DC
LZ120-16	800	0,5 mm <sup>2</sup>	G	B	black/black	2,8 x 0,5	AC
LZ120-18	4 000	0,5 mm <sup>2</sup>	G	A	black/black	2,8 x 0,5	AC
LZ126	1 000	0,5 mm <sup>2</sup>	G	C	black/black	2,8 x 0,5	AC
LZ127	1 600	0,5 mm <sup>2</sup>	G	B	black/black	2,8 x 0,5	AC
LZ130-1	610	0,82 mm <sup>2</sup>	G	C	black/black	2,8 x 0,5	AC *
LZ140	610	0,73 mm <sup>2</sup>	G	B	black/black	2,8 x 0,8	AC

\* UL-approved

Connection cable Straight plug (G)

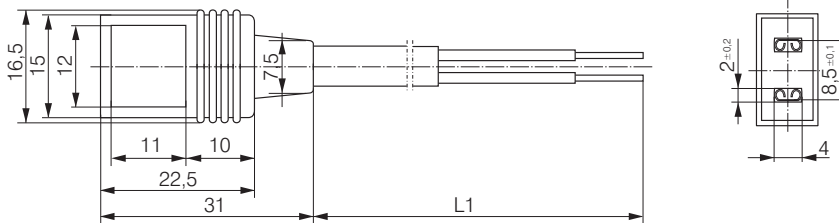

Connection cable Angled plug (W)

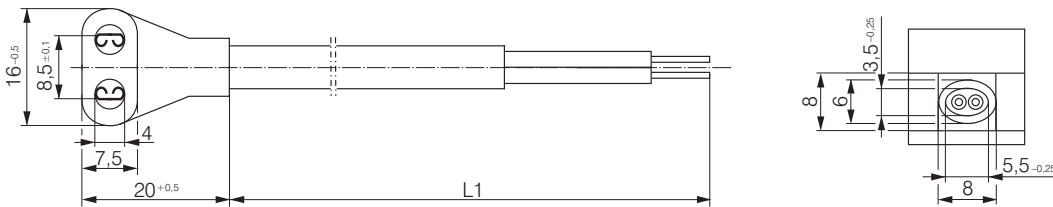

Cor crimp sleeve Leads end A

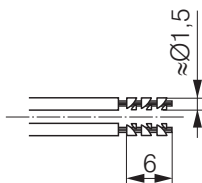

Tin-plated Leads end B

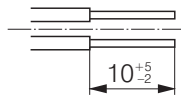

Core end sleeve Leads end C

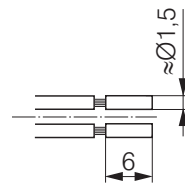



# Connection leads (ESM) / Handheld Programmer

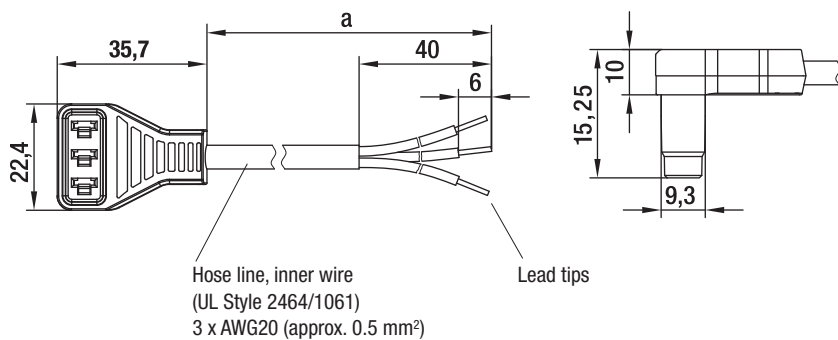

- **Design:** Cable conforms to UL standards, sealed plug. Custom-built connection leads on request.

## Connection leads for energy-saving motors 115/230 VAC

Part no.	a
13060-4-1040	450
13061-4-1040	1500

Subject to alternations



- Easy speed programming
- Battery operated
- User-friendly navigation menu
- Protective boot with kickstand

## For Energy Saving Motor (ESM) based products

Part no.

**CBC 000-AF08-01**

Subject to alternations

Makes quick work of programming the two ESM selectable operating speeds. Eliminates the need for a personal computer, software, power adapter and 2nd cable. Good for production line or field service use. Automatic shut-off function for an extended battery life. Mini-USB connector for uploading software upgrades. Batteries, programming cable and operating manual included.

# Accessories

In addition to the accessories and assembly parts listed in this catalogue, ebm-papst also supplies numerous special parts for fans. The sales experts at ebm-papst will be happy to assist you in your enquiries concerning fan assembly and application.

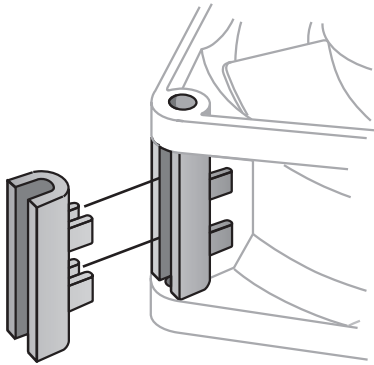

Fan series	Accessories
8300	LZ212 / LZ260
8400 N	LZ261
3300	LZ212 / LZ260
3400 N	LZ261
9000	LZ210
4000	LZ210
4300	LZ212 / LZ260
8300	LZ212

Fan series	Accessories
5100	LZ210
5600	LZ210
5200	LZ210
5900	LZ210
7000	LZ210
VARIOFAN	LZ370

## LZ212

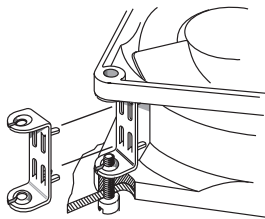

Screw clip of stainless steel. For mounting fans with threaded pin 3.5 DIN EN ISO 1478 (7970).

## LZ260/LZ261

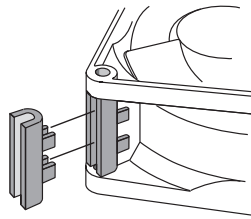

Spacer of fibreglass reinforced plastic. For screw mounting over both fan mounting flanges.

## LZ210



Screw clip of hardened steel. For mounting fans with threaded pin 6-32 UNC and/or 3.5 DIN 7970.

## LZ370

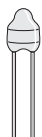

Required performance data:

$R_{25}$	= 100 K $\Omega$ $\pm$ 5% @25°C
B-value	= 4190 $\pm$ 2%
$P_{max}$	= 0,25 W

Temperature sensor for speed-controlled fan operation. Temperature range 30...50 °C.

## LZ550

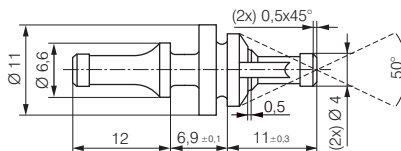

Rubber anti-vibration mounts for fans with a hole  $\varnothing$  of 4.3  $\pm$ 0.2 mm and flange thickness of 3 - 5.5 mm. For a carrier plate with a hole  $\varnothing$  of 6.5  $\pm$ 0.15 mm and plate thickness of 1 - 2 mm.

# Electrical connections EC

## E)

### Technical features (Nominal voltage 24 / 48 VDC):

- Control input 0-10 VDC / PWM
- Tach output
- Reverse polarity and locked-rotor protection
- Motor current limitation
- Voltage-dependent derating
- Over-temperature protected electronics / motor
- Soft start

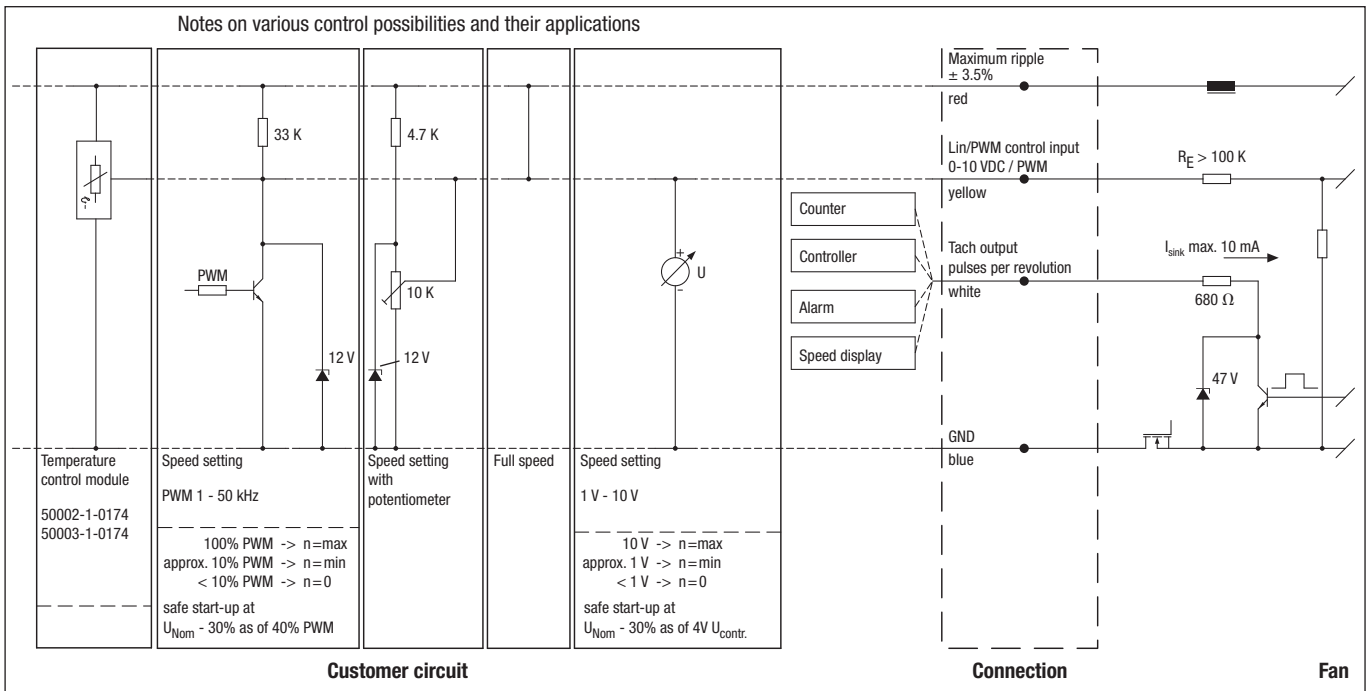

### Line 1

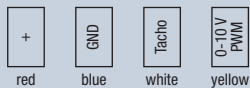

Line	Connection	Colour	Assignment / function	Line	Connection	Colour	Assignment / function
1	+	red	Maximum ripple ± 3.5 %	1	Tacho	white	Tach output
	GND	blue	GND		0-10 V / PWM	yellow	Control input

# Electrical connections EC

## G)

### Technical features (Nominal voltage 24 / 48 VDC):

- Control input 0-10 VDC / PWM
- Tach output
- Reverse polarity and locked-rotor protection

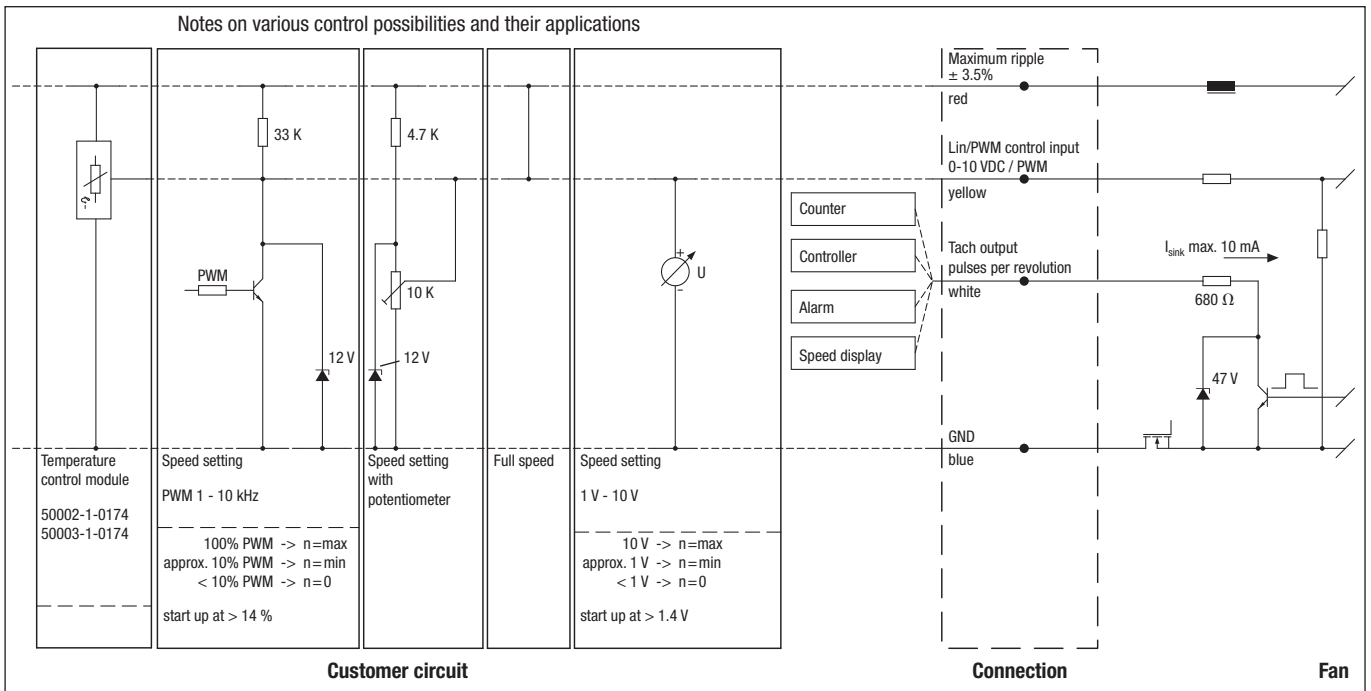

### Line 1



Line	Connection	Colour	Assignment / function
1	+	red	Maximum ripple $\pm 3.5\%$
	GND	blue	GND

Line	Connection	Colour	Assignment / function
1	Tacho	white	Tach output: 2 pulses / revolution (M1G045/M1G055) 3 pulses / revolution (M1G074/M1G084)
	0-10 V / PWM	yellow	Control input (Impedance 100 k $\Omega$ )

# Electrical connections EC H3)

## Technical features (M3G 045 / M3G 055 with 2 Speed stages):

- Speed adjustment input (230V)
- Over-temperature protected electronics / motor
- Motor current limitation
- Locked-rotor protection
- Soft start

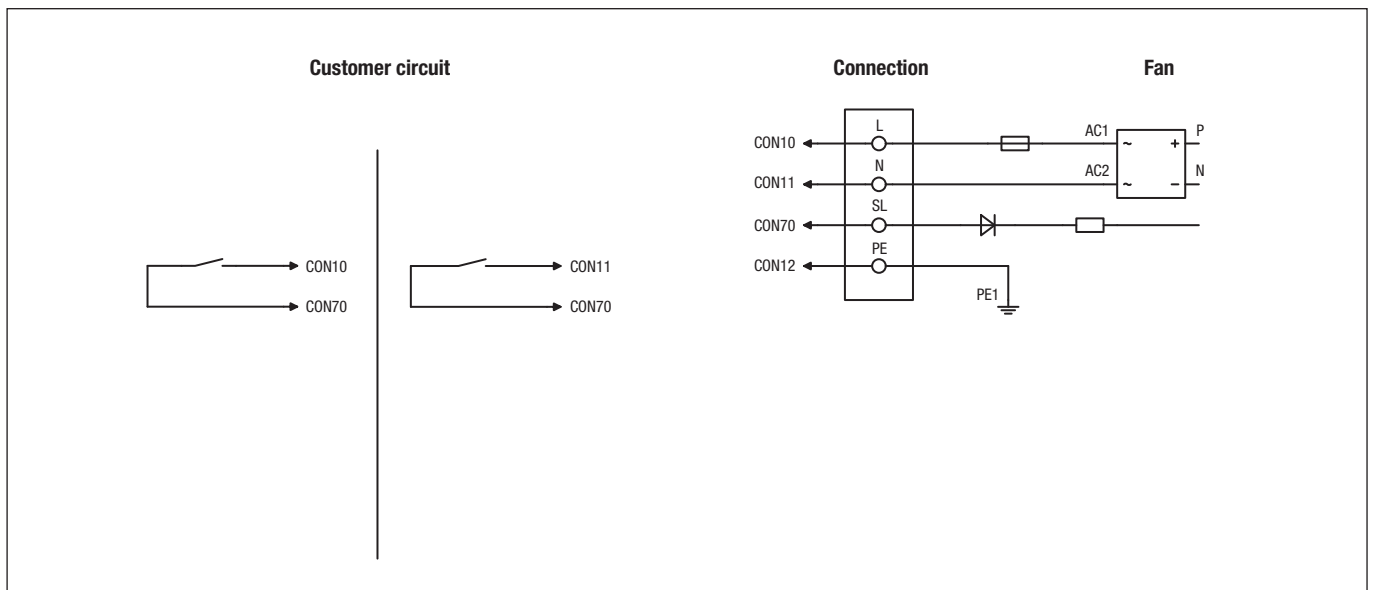

Line	Connection	Colour	Assignment / function
CON10	L	black	Power supply 230 VAC, 50 - 60 Hz, see type plate for voltage range
CON11	N	blue	Neutral conductor
CON12	PE	green/yellow	Protective earth
CON70	SL	brown	Speed selection: switch open = speed 1; switch closed = speed 2

# Electrical connections EC H4)

## Technical features (M3G 055 Speed-controlled):

- Output 10 VDC max. 1,1 mA
- Tach output
- Over-temperature protected electronics / motor
- Motor current limitation
- Soft start
- Locked-rotor protection
- Control input 0-10 VDC / PWM
- Control interface with SELV potential safely disconnected from the mains

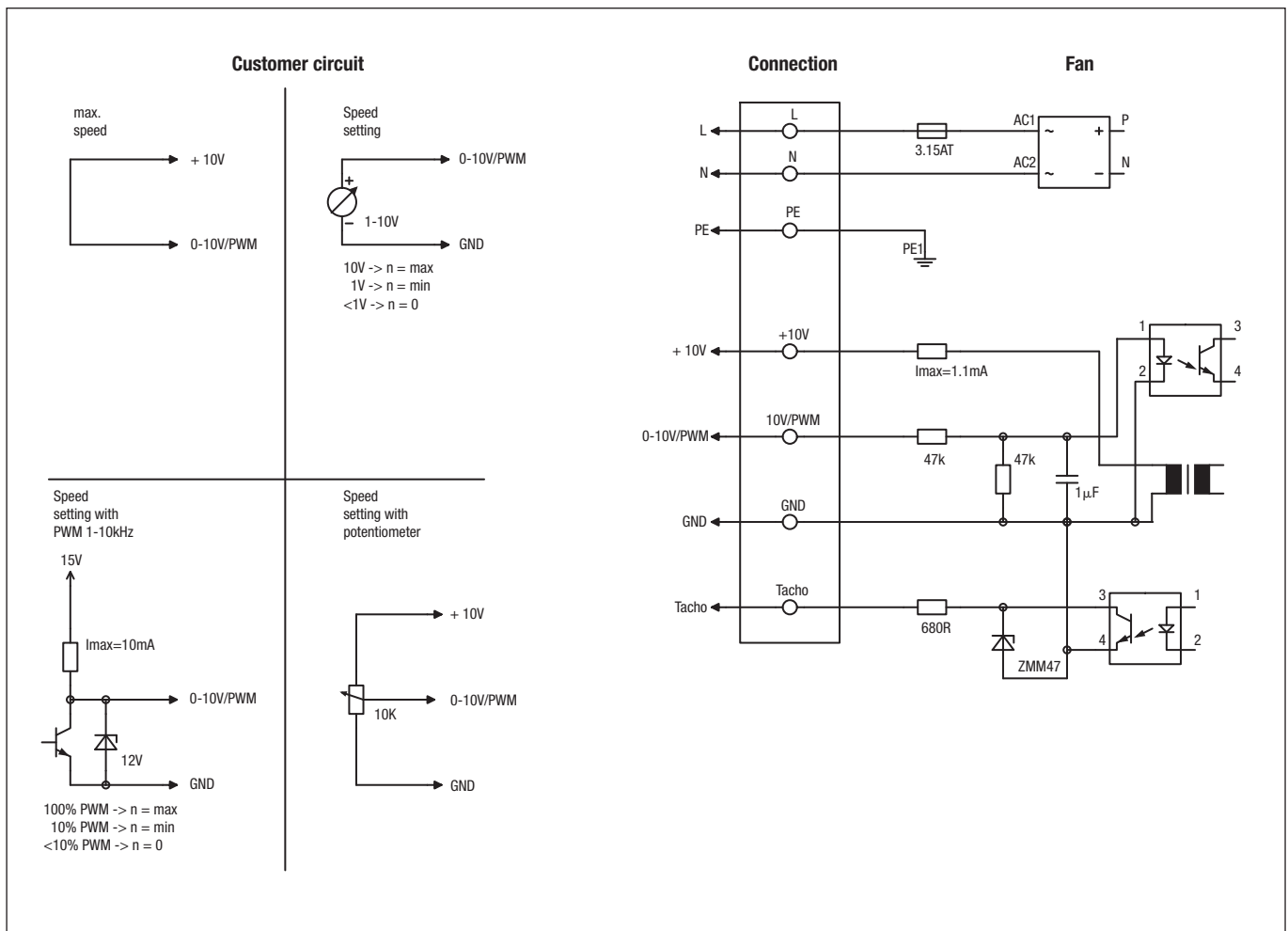

Connection	Colour	Assignment / function
L	black	Power supply 230 VAC, 50 - 60 Hz, see type plate for voltage range
N	blue	Neutral conductor
PE	green/yellow	Protective earth
+10V/max.1.1mA	red	Voltage output +10 V / 1.1 mA, electrically isolated, not short-circuit-proof
Tacho	white	Tach output: Open Collector, 1 pulse per revolution, electrically isolated
0-10V PWM	yellow	Control input 0 - 10 V or PWM, electrically isolated
GND	blue	GND - Connection for control interface

# Electrical connections EC J5)

## Technical features (Nominal voltage 24 / 48 VDC):

- Control input 0-10 VDC / PWM
- Tach output
- Reverse polarity and locked-rotor protection
- Motor current limitation
- Line undervoltage detection
- Soft start

### Notes on various control possibilities and their applications

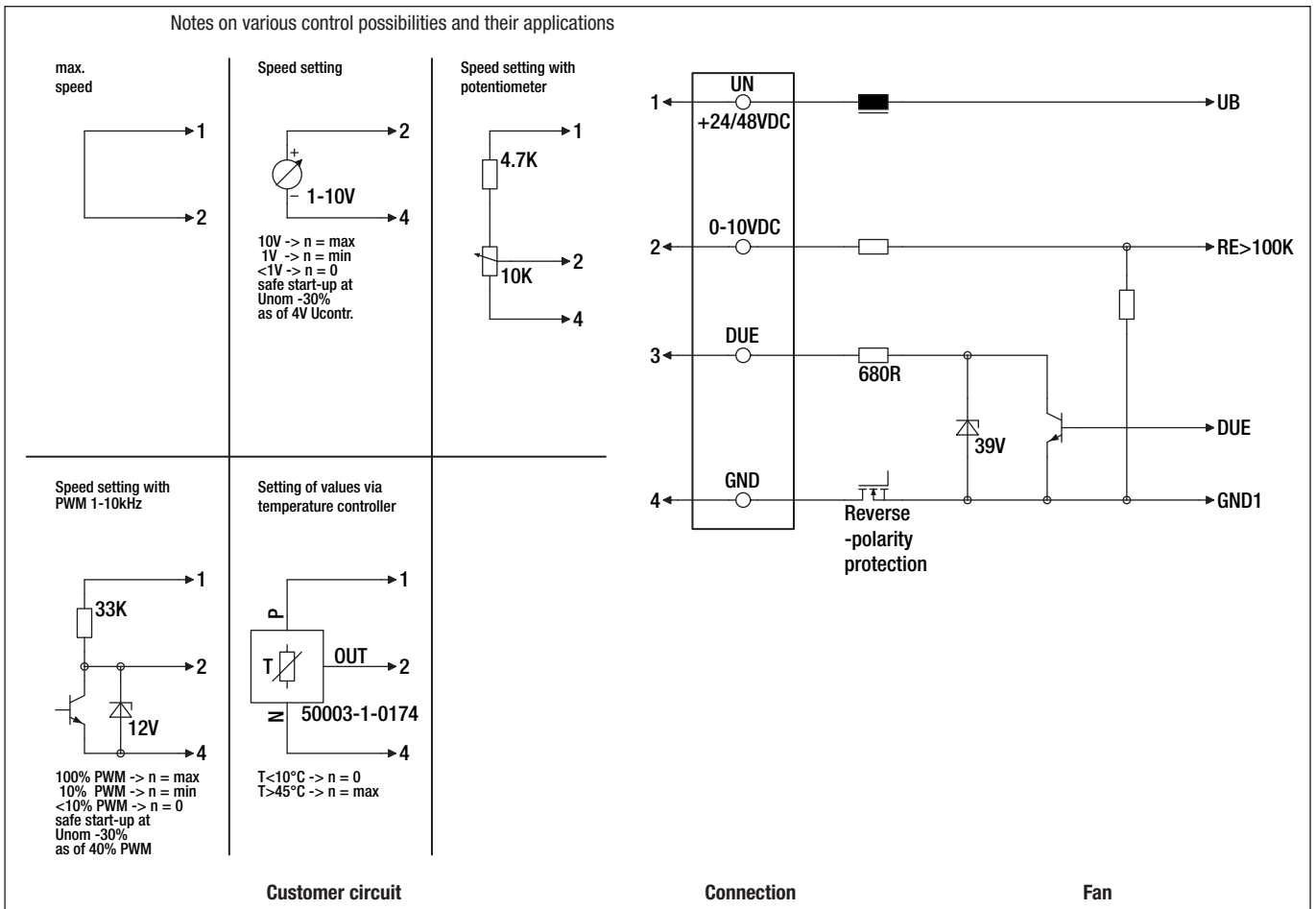

Line	Connection	Colour	Assignment / function
1	UN +24/48 VDC	red	Power supply 24/48 VDC, Maximum ripple $\pm 3,5\%$
2	0-10 VDC	yellow	Control input Re $>100\text{ K}$
3	Tach	white	Speed monitoring output, 3 pulses / revolution, Isink max. = 10 mA
4	GND	blue	Reference ground



# Electrical connections AC A1) / C2 / J7)

## A1) Single-phase capacitor motor (1~ 115/230 VAC power line) with TOP wired internally

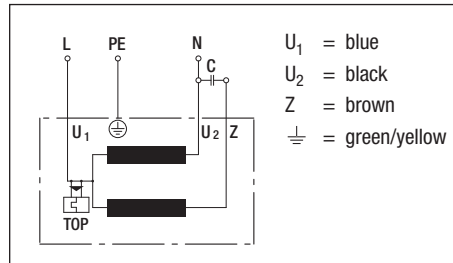

## C2) Star connection (3~ 400 VAC power line) without TOP

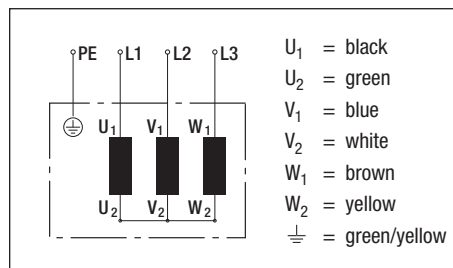

## J7) Energy-saving motor (ESM) (1~ 115/230 VAC power line)

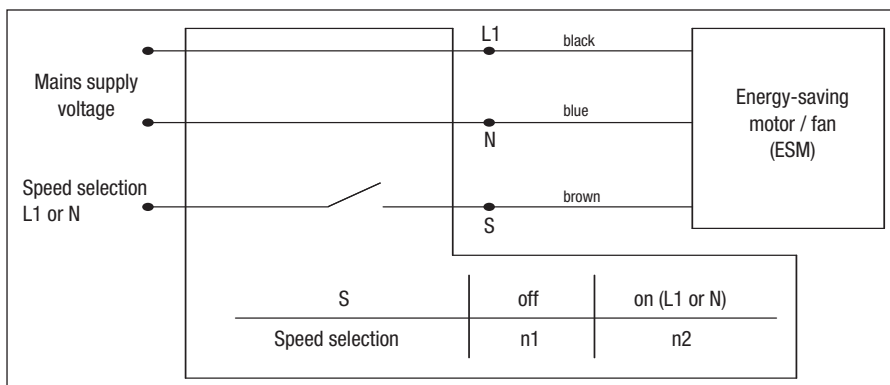

# ebm-papst in Germany

## ebm-papst Mulfingen GmbH & Co. KG

Bachmühle 2  
74673 Mulfingen  
GERMANY  
Phone +49 7938 81-0  
Fax +49 7938 81-110  
info1@de.ebmpapst.com

## ebm-papst St. Georgen GmbH & Co. KG

Hermann-Papst-Straße 1  
78112 St. Georgen  
GERMANY  
Phone +49 7724 81-0  
Fax +49 7724 81-1309  
info2@de.ebmpapst.com

## ebm-papst Landshut GmbH

Hofmark-Aich-Straße 25  
84030 Landshut  
GERMANY  
Phone +49 871 707-0  
Fax +49 871 707-465  
info3@de.ebmpapst.com

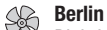

### Berlin

Dipl.-Ing. (TH) Jens Duchow  
Händelstraße 7  
16341 Panketal  
GERMANY  
Phone +49 30 944149-62  
Fax +49 30 944149-63  
Jens.Duchow@de.ebmpapst.com



### Bielefeld

Dipl.-Ing. (FH) Wolf-Jürgen Weber  
Niehausweg 13  
33739 Bielefeld  
GERMANY  
Phone +49 5206 91732-31  
Fax +49 5206 91732-35  
Wolf-Juergen.Weber@de.ebmpapst.com



### Dortmund

Dipl.-Ing. (FH) Hans-Joachim Pundt  
Auf den Steinern 3  
59519 Möhnesee-Völlinghausen  
GERMANY  
Phone +49 2925 800-407  
Fax +49 2925 800-408  
Hans-Joachim.Pundt@de.ebmpapst.com



### Frankfurt

Dipl.-Ing. Christian Kleffmann  
Dr.-Hermann-Krause-Straße 23  
63452 Hanau  
GERMANY  
Phone +49 6181 1898-12  
Fax +49 6181 1898-13  
Christian.Kleffmann@de.ebmpapst.com



### Halle

Dipl.-Ing. (TU) Michael Hanning  
Lercheneck 4  
06198 Salztal / OT Lieskau  
GERMANY  
Phone +49 345 55124-56  
Fax +49 345 55124-57  
Michael.Hanning@de.ebmpapst.com



### Hamburg

Breuell & Hilgenfeldt GmbH  
Ing. Dirk Kahl  
Elektroingenieur  
Grützmühlenweg 48  
22339 Hamburg  
GERMANY  
Phone +49 40 538092-19  
Fax +49 40 538092-84  
Dirk.Kahl@de.ebmpapst.com



### Heilbronn / Heidelberg

Dipl.-Ing. Mark Gartner  
Gehrweg 12  
74199 Unterheinriet  
GERMANY  
Phone +49 7130 404569-1  
Fax +49 7130 404569-2  
Mark.Gartner@de.ebmpapst.com



### Kassel

Dipl.-Ing. (FH) Ralph Brück  
Hoherainstraße 38  
35075 Gladenbach  
GERMANY  
Phone +49 6462 4071-10  
Fax +49 6462 4071-11  
Ralph.Brueck@de.ebmpapst.com



### Koblenz

Winfried Schaefer  
Hinter der Kirch 10  
56767 Uersfeld  
GERMANY  
Phone +49 2657 16-96  
Fax +49 2657 16-76  
Winfried.Schaefer@de.ebmpapst.com



### Munich

Dipl.-Wirt.-Ing. (FH) Jens Peter  
Uhländstraße 6  
74427 Fichtenberg  
GERMANY  
Phone +49 7971 260-180  
Fax +49 7971 260-221  
Jens.Peter@de.ebmpapst.com



### Nuremberg

Dipl.-Wirt.-Ing. (FH) Axel Resch  
Dr.-August-Koch-Str. 1  
91639 Wolframs-Eschenbach  
GERMANY  
Phone +49 9875 9783-170  
Fax +49 9875 9783-171  
Axel.Resch@de.ebmpapst.com



### Offenburg

Dipl.-Ing. (FH) Ralf Braun  
Hubeneck 21  
77704 Oberkirch  
GERMANY  
Phone +49 7802 9822-52  
Fax +49 7802 9822-53  
Ralf.Braun@de.ebmpapst.com



### Stuttgart

Dipl.-Ing. (FH) Rudi Weinmann  
Hindenburgstraße 100/1  
73207 Plochingen  
GERMANY  
Phone +49 7153 9289-80  
Fax +49 7153 9289-81  
Rudi.Weinmann@de.ebmpapst.com



### Ulm

M.Sc. Reinhard Sommerreißer  
Am Silbermannpark 10  
86161 Augsburg  
GERMANY  
Phone +49 821 6610-7023  
Fax +49 821 6610-7024  
Reinhard.Sommerreisser@de.ebmpapst.com

## Distributors



### Burgdorf

ETB Electronic Team  
Beratungs- u. Vertriebs GmbH  
Wundramweg 1  
31303 Burgdorf  
GERMANY  
Phone +49 5136 97229-30  
Fax +49 5136 97229-39  
info@etb-electronic.de  
www.etb-electronic.de



### Frankfurt

R.E.D. Handelsgesellschaft mbH  
Gutenbergstraße 3  
63110 Rodgau - Jügesheim  
GERMANY  
Phone +49 6106 841-0  
Fax +49 6106 841-111  
info@red-elektromechanik.de  
www.red-elektromechanik.de



### Frankfurt / Neu-Isenburg

Arrow Central Europe GmbH  
Frankfurter Straße 211  
63263 Neu-Isenburg  
GERMANY  
Telefon: +49(0)6102/5030-0  
Telefax: +49(0)6102/5030-8455  
E-Mail: info@arrowce.com



### Hamburg

Breuell + Hilgenfeldt GmbH  
Grützmühlenweg 48  
22339 Hamburg  
GERMANY  
Phone +49 40 538092-20  
Fax +49 40 538092-84  
info@breuell-hilgenfeldt.de



### Walter Kluxen GmbH













Neuer Höltingbaum 6  
20097 Hamburg  
GERMANY  
Phone +49 40 237010  
Fax +49 40 23701309

# ebm-papst in Europe



-  **Klausdorf**  
ETB Electronic Team  
Beratungs- u. Vertriebs GmbH  
Zossener Straße 27  
15838 Klausdorf  
GERMANY  
Phone +49 33703 69-0  
Fax +49 33703 69-149  
info@etb-electronic.de  
www.etb-electronic.de
-  **Munich**  
A. Schweiger GmbH  
Ohmstraße 1  
82054 Sauerlach  
GERMANY  
Phone +49 8104 897-0  
Fax +49 8104 897-90  
info@schweiger-gmbh.de  
www.schweiger-gmbh.com
-  **Multi-Bauelemente-Service**  
Vertrieb von elektr. Bauelementen GmbH  
Römerstraße 8  
85661 Forstinning  
GERMANY  
Phone +49 8121 2506-0  
Fax +49 8121 2506-200  
multi.bauelemente@mbs.to
- **Express Service-Center** (1 to 5 pieces)
-  **North**  
Breuell + Hilgenfeldt GmbH  
Grützmühlenweg 48  
22339 Hamburg  
GERMANY  
Phone +49 40 538092-20  
Fax +49 40 538092-84  
ebmpapst@breuell-hilgenfeldt.de
-  **South**  
Scheffel  
elektrotechnischer Vertrieb GmbH  
Aischbach 1  
70839 Gerlingen  
GERMANY  
Phone +49 7156 28357  
Fax +49 7156 49425  
info@ebmpapst-service.de



## Europe

-  **Austria**  
ebm-papst Motoren & Ventilatoren GmbH  
Straubingstraße 17  
4030 Linz  
AUSTRIA  
Phone +43 732 321150-0  
Fax +43 732 321150-20  
info@at.ebmpapst.com  
www.ebmpapst.at
-  **Avnet Abacus Vienna**  
Schönbrunner Str. 297-307  
1120 Vienna  
AUSTRIA  
Phone +43 1 86642-0  
Fax +43 1 86642-250  
wien@avnet-abacus.eu  
www.avnet-abacus.eu
-  **Compex Ges.m.b.H**  
Wurlitzergasse 10/3  
1160 Wien  
AUSTRIA  
Phone +43 1 4804223  
Fax +43 1 4864230  
compex.wien@utanet.at
-  **Belarus**  
ebm-papst Bel AgmbH  
Lipkovskaya Gasse 34  
Office No. 6, Room 106, 107  
223010 Minsk  
BELARUS  
Phone +375 17 3851556  
Fax +375 17 3851556  
info@by.ebmpapst.com  
www.ebmpapst.by
-  **Belgium**  
ebm-papst Benelux B.V.  
Sales office Belgium-Luxemburg  
Romeinsestraat 6/0101  
Research Park Haasrode  
3001 Heverlee-Leuven  
BELGIUM  
Phone +32 16 396-200  
Fax +32 16 396-220  
info@be.ebmpapst.com  
www.ebmpapst.be
-  **Avnet Abacus Diegem**  
Eagle Building  
Kouterveldstraat 20  
1831 Diegem  
BELGIUM  
Phone +32 2 7099 167  
Fax +32 2 7099 801  
diegem@avnet-abacus.eu  
www.avnet-abacus.eu
-  **Bulgaria**  
ebm-papst Romania S.R.L.  
Str. Tarnavei No. 20  
500327 Brasov  
ROMANIA  
Phone +40 268 331859  
Fax +40 268 312805  
dudasludovic@xnet.ro
-  **Compex Ges.m.b.H**  
Wurlitzergasse 10/3  
1160 Wien  
AUSTRIA  
Phone +43 1 4804223  
Fax +43 1 4864230  
compex.wien@utanet.at
-  **Croatia**  
ebm-papst Industries Kft.  
Ezred u. 2.  
1044 Budapest  
HUNGARY  
Phone +36 1 8722-190  
Fax +36 1 8722-194  
office@hu.ebmpapst.com
-  **Compex Ges.m.b.H**  
Wurlitzergasse 10/3  
1160 Wien  
AUSTRIA  
Phone +43 1 4804223  
Fax +43 1 4864230  
compex.wien@utanet.at
-  **Czech Republic / Slovakia**  
ebm-papst CZ s.r.o.  
Kaštanová 34a  
620 00 Brno  
CZECH REPUBLIC  
Phone +420 544 502-411  
Fax +420 547 232-622  
info@ebmpapst.cz  
www.ebmpapst.cz
-  **Denmark**  
ebm-papst Denmark ApS  
Vallensbækvej 21  
2605 Brøndby  
DENMARK  
Phone +45 43 631111  
Fax +45 43 630505  
mail@dk.ebmpapst.com  
www.ebmpapst.dk
-  **Estonia**  
ebm-papst Oy, Eesti Filiaal  
Kesk tee 13  
Aaviku küla, Jüri Tehnospark  
75301 Rae Vald, Harjumaa  
ESTONIA  
Phone +372 65569-78  
Fax +372 65569-79  
www.ebmpapst.ee

# ebm-papst in Europe



 **Finland**  
ebm-papst Oy  
 Puistotie 1  
 02760 Espoo  
FINLAND  
Phone +358 9 887022-0  
Fax +358 9 887022-13  
mailbox@ebmpapst.fi  
www.ebmpapst.fi

 **France**  
ebm-papst sarl  
 ZI Nord - rue A. Mohler  
 BP 62  
67212 Obernai Cedex  
FRANCE  
Phone +33 820 326266  
Fax +33 3 88673883  
info@ebmpapst.fr  
www.ebmpapst.fr

 **Greece**  
Helcoma  
 Th. Rotas & Co OE  
 Davaki 65  
17672 Kallithea-Attiki  
GREECE  
Phone +30 210 9513-705  
Fax +30 210 9513-490  
contact@helcoma.gr  
www.helcoma.gr

 Assimacopoulos S.A.  
11, Karitsi Square  
10561 Athen  
GREECE  
Phone +30 10 322 1737  
Fax +30 10 322 5708  
assimac@interagora.gr  
www.assimacopoulos.gr

 **Hungary**  
ebm-papst Industries Kft.  
 Ezred u. 2.  
 1044 Budapest  
HUNGARY  
Phone +36 1 8722-190  
Fax +36 1 8722-194  
office@hu.ebmpapst.com

 **Iceland**  
RJ Engineers  
 Stangarhyl 1a  
 110 Reykjavik  
ICELAND  
Phone +354 567 8030  
Fax +354 567 8015  
rj@rj.is  
www.rj.is

 **Ireland**  
ebm-papst UK Ltd.  
 Chelmsford Business Park  
 Chelmsford Essex CM2 5EZ  
UNITED KINGDOM  
Phone +44 1245 468555  
Fax +44 1245 466336  
sales@uk.ebmpapst.com  
www.ebmpapst.co.uk

 **Italy**  
ebm-papst Srl  
 Via Cornaggia 108  
 22076 Mozzate (Co)  
ITALY  
Phone +39 0331 836201  
Fax +39 0331 821510  
info@it.ebmpapst.com  
www.ebmpapst.it

 **Macedonia**  
ebm-papst Industries Kft.  
 Ezred u. 2.  
 1044 Budapest  
HUNGARY  
Phone +36 1 8722-190  
Fax +36 1 8722-194  
office@hu.ebmpapst.com

 **Netherlands**  
ebm-papst Benelux B.V.  
 Engelseweg 127  
 5705 AC Helmond  
NETHERLANDS  
Phone +31 492 502-900  
Fax +31 492 502-950  
verkoop@nl.ebmpapst.com  
www.ebmpapst.nl

 Avnet Abacus Netherlands  
Takkebijsters 2  
4817 BL Breda  
NETHERLANDS  
Phone +31 765 722 300  
Fax +31 765 722 303  
breda@avnet-abacus.eu  
www.avnet-abacus.eu

 **Norway**  
ebm-papst AS  
 Nordåsveien 5  
 1251 Oslo  
NORWAY  
Phone +47 22 763340  
Fax +47 22 619173  
mailbox@ebmpapst.no  
www.ebmpapst.no

 **Poland**  
ebm-papst Polska Sp. z o.o.  
 ul. Annopol 4A  
 03236 Warszawa  
POLAND  
Phone +48 22 6757819  
Fax +48 22 6769587  
office@ebmpapst.pl  
www.ebmpapst.pl

 Compex Ges.m.b.H  
 Wurlitzergasse 10/3  
1160 Wien  
AUSTRIA  
Phone +43 1 4804223  
Fax +43 1 4864230  
compex.wien@utanet.at

 **Portugal**  
ebm-papst (Portugal), Lda.  
 Centro Empresarial de Alverca  
 Rua de Adarse, Vale D'Ervas  
Corpo D / Fracção 3  
2615-178 Alverca do Ribatejo  
PORTUGAL  
Phone +351 218 394 880  
Fax +351 218 394 759  
info@pt.ebmpapst.com  
www.ebmpapst.pt

 **Romania**  
ebm-papst Romania S.R.L.  
 Str. Tarnavei Nr. 20  
 500327 Brasov  
ROMANIA  
Phone +40 268 331859  
Fax +40 268 312805  
dudasludovic@xnet.ro

 Compex Ges.m.b.H  
 Wurlitzergasse 10/3  
1160 Wien  
AUSTRIA  
Phone +43 1 4804223  
Fax +43 1 4864230  
compex.wien@utanet.at

 **Russia**  
ebm-papst Ural GmbH  
 Posadskaja-Strasse, 23(E), 3  
 620102 Ekaterinburg  
RUSSIA  
Phone +7 343 2338000  
Fax +7 343 2337788  
Konstantin.Molokov@ru.ebmpapst.com  
www.ebmpapst.ur.ru

 ebm-papst Rus GmbH  
 proezd 4529, vladenie 5, stroenie 1  
 141000 Mytistschi, Oblast Moskau  
RUSSIA  
Phone +7 495 9807524  
Fax +7 495 5140924  
info@ebmpapst.ru  
www.ebmpapst.ru

# ebm-papst in Europe and America

 **Serba & Montenegro**  
ebm-papst Industries Kft.  
Ezred u. 2.  
1044 Budapest  
HUNGARY  
Phone +36 1 8722-190  
Fax +36 1 8722-194  
office@hu.ebmpapst.com

 **Spain**  
ebm-papst Ibérica S.L.  
Avda. del Sistema Solar, 29  
28830 San Fernando de Henares (Madrid)  
SPAIN  
Phone +34 91 6780894  
Fax +34 91 6781530  
ventas@ebmpapst.es  
www.ebmpapst.es

 **Sweden**  
ebm-papst AB  
Äggelundavägen 2  
17562 Järfälla  
SWEDEN  
Phone +46 10 4544400  
Fax +46 8 362306  
info@ebmpapst.se  
www.ebmpapst.se

 **Switzerland**  
ebm-papst AG  
Rütisbergstrasse 1  
8156 Oberhasli  
SWITZERLAND  
Phone +41 44 73220-70  
Fax +41 44 73220-77  
verkauf@ebmpapst.ch  
www.ebmpapst.ch

 **Omni Ray AG**  
Im Schörli 5  
8600 Dübendorf  
SWITZERLAND  
Phone +41 44 802 2880  
Fax +41 44 802 2828  
r.borner@omniray.ch  
www.omniray.ch

 **Turkey**  
Akantel Elektronik San. Tic. LTD. Sti.  
Atatürk Organize Sanayi  
Bölgesi 10007 SK. No.:6  
35620 Cigli-Izmir  
TURKEY  
Phone +90 232 3282090  
Fax +90 232 3280270  
akantel@akantel.com.tr  
www.ebmpapst.com.tr

 **Ukraine**  
ebm-papst Ukraine LLC  
Lepse Boulevard, 4, Building 21  
03067 Kiev  
UKRAINE  
Phone +38 044 2063091  
Fax +38 044 2063091  
mail@ebmpapst.ua  
www.ebmpapst.ua

 **United Kingdom**  
ebm-papst UK Ltd.  
Chelmsford Business Park  
Chelmsford Essex CM2 5EZ  
UNITED KINGDOM  
Phone +44 1245 468555  
Fax +44 1245 466336  
sales@uk.ebmpapst.com  
www.ebmpapst.co.uk

 **ebm-papst Automotive & Drives (UK) Ltd.**  
The Smithy  
Fidlers Lane  
East Ilsley, Berkshire RG20 7LG  
UNITED KINGDOM  
Phone +44 1635 2811-11  
Fax +44 1635 2811-61  
A&Dsales@uk.ebmpapst.com  
www.ebmpapst-ad.com

## America

 **Argentina**  
ebm-papst de Argentina S.A.  
Hernandarias 148 Lomas del Mirador  
Pcia. de Buenos Aires (1752)  
ARGENTINA  
Phone +54 11 46576135  
Fax +54 11 46572092  
ventas@ar.ebmpapst.com  
www.ebmpapst.com.ar

 **Brasil**  
ebm-papst Motores Ventiladores Ltda.  
Av. José Giorgi, 301 Galpões B6+B7  
Condominio Logical Center  
06707-100 Cotia - São Paulo  
BRAZIL  
Phone +55 11 4613-8700  
Fax +55 11 4777-1456  
vendas@br.ebmpapst.com  
www.ebmpapst.com.br

 **Canada**  
ebm-papst Canada Inc.  
1800 Ironstone Manor, Unit 2  
Pickering, Ontario, L1W3J9  
CANADA  
Phone +1 905 420-3533  
Fax +1 905 420-3772  
sales@ca.ebmpapst.com  
www.ebmpapst.ca

 **Mexico**  
ebm Industrial S. de R.L. de C.V.  
Paseo de Tamarindos 400-A-5º Piso  
Col. Bosques de las Lomas  
Mexico 05120, D.F.  
MEXICO  
Phone +52 55 3300-5144  
Fax +52 55 3300-5243  
sales@mx.ebmpapst.com  
www.ebmpapst.com.mx

 **USA**  
ebm-papst Inc.  
P.O. Box 4009  
100 Hyde Road  
Farmington, CT 06034  
UNITED STATES  
Phone +1 860 674-1515  
Fax +1 860 674-8536  
sales@us.ebmpapst.com  
www.ebmpapst.us

 **ebm-papst Automotive & Drives, Inc.**  
3200 Greenfield, Suite 255  
Dearborn, MI 48120  
UNITED STATES  
Phone +1 313 406-8080  
Fax +1 313 406-8081  
automotive@us.ebmpapst.com  
www.ebmpapst-automotive.us

# ebm-papst in Africa, Asia and Australia



## Africa

 **South Africa**  
ebm-papst South Africa (Pty) Ltd.  
 P.O. Box 3124  
 1119 Yacht Avenue  
2040 Honeydew  
SOUTH AFRICA  
Phone +27 11 794-3434  
Fax +27 11 794-5020  
info@za.ebmpapst.com  
www.ebmpapst.co.za

## Asia

 **China**  
ebm-papst Ventilator (Shanghai) Co., Ltd.  
 No. 418, Hua Jing Road  
 Wai Gao Qiao Free Trade Zone  
No. 2001, Yang Gao (N) Road  
200131 Shanghai  
P.R. of CHINA  
Phone +86 21 5046-0183  
Fax +86 21 5046-1119  
sales@cn.ebmpapst.com  
www.ebmpapst.com.cn

 **Hong Kong**  
ebm-papst Hong Kong Ltd.  
 Room 17E, MG Tower  
 133 Hoi Bun Road, Kwun Tong  
Hong Kong  
P.R. of CHINA  
Phone +852 2145-8678  
Fax +852 2145-7678  
info@hk.ebmpapst.com

 **India**  
ebm-papst India Pvt. Ltd.  
 26/3, G.N.T. Road, Erukkencherry  
 Chennai-600118  
INDIA  
Phone +91 44 25372556  
Fax +91 44 25371149  
sales@in.ebmpapst.com  
www.ebmpapst.in

 **Indonesia**  
ebm-papst Indonesia  
 Representative Office  
 German Centre, 4th Floor, Suite 4470  
Jl. Kap. Subijono Dj. Bumi Serpong Damai  
15321 Tangerang  
INDONESIA  
Phone +62 21 5376250  
Fax +62 21 5388305  
salesdept@id.ebmpapst.com

 **Israel**  
Polak Bros. Import Agencies Ltd.  
 9 Hamefalsim Street  
 Kiryat Arie, Petach-Tikva 49514  
ISRAEL  
Phone +972 3 9100300  
Fax +972 3 5796679  
polak@polak.co.il  
www.polak.co.il

 **Japan**  
ebm-papst Industries Japan K.K.  
 12th Floor, Benex S-3 Bldg.  
 3-20-8 Shinyokohama, Kohoku-ku  
222-0033 Yokohama  
JAPAN  
Phone +81 45 47057-51  
Fax +81 45 47057-52  
info@jp.ebmpapst.com  
www.ebmpapst.jp

 **Korea**  
ebm-papst Korea Co. Ltd.  
 6F, Trutec Bldg.  
 B 6-2, Digital Media City (DMC)  
Sangam-Dong, Mapu-Gu  
Seoul 121-270  
KOREA  
Phone +82 2 366213-24  
Fax +82 2 366213-26  
info@kr.ebmpapst.com  
www.ebmpapst.co.kr

 **Malaysia**  
ebm-papst Malaysia  
 Representative Office  
 Unit 12-2, Jalan USJ Sentral 3  
Persiaran Subang, Selangor Darul Ehsan  
47600 Subang Jaya  
MALAYSIA  
Phone +60 3 8024-1680  
Fax +60 3 8024-8718  
salesdept@my.ebmpapst.com

 **Singapore**  
ebm-papst SEA Pte. Ltd.  
 No. 23 Ubi Road 4  
 #06-00 Olympia Industrial Building  
Singapore 408620  
SINGAPORE  
Phone +65 65513789  
Fax +65 68428439  
salesdept@sg.ebmpapst.com

 **Taiwan**  
ETECO Engineering & Trading Corp.  
 6F-4, No. 93, Ta-sun 1 St. Road  
 Tsow-Inn District, Kaohsiung  
TAIWAN  
Phone +886 7 557-4268  
Fax +886 7 557-2788  
eteco@ms22.hinet.net  
www.ebmpapst.com.tw

 **Thailand**  
ebm-papst Thailand Co., Ltd.  
 99/9 Moo 2, Central Chaengwattana Tower  
 14th Floor, Room 1402  
Chaengwattana Road Bangtarad, Pakkret  
11120 Nonthaburi  
THAILAND  
Phone +66 2 8353785-7  
Fax +66 2 8353788  
salesdept@th.ebmpapst.com

 **United Arab Emirates**  
ebm-papst Middle East FZE  
 PO Box 17755  
 Jebel Ali Free Zone / FZS1 / AP05  
Dubai  
UNITED ARAB EMIRATES  
Phone +971 4 88608-26  
Fax +971 4 88608-27  
info@ae.ebmpapst.com  
www.ebmpapst.ae

 **Vietnam**  
ebm-papst Vietnam  
 Representative Office  
 Room #102, 25 Nguyen Van Thu Street  
District 1  
Ho Chi Minh City 70000  
VIETNAM  
Phone +84 8 39104099  
Fax +84 8 39103970  
linh.nguyen@vn.ebmpapst.com

## Australia

 **Australia**  
ebm-papst A&NZ Pty Ltd.  
 10 Oxford Road  
 Laverton North, Victoria, 3026  
AUSTRALIA  
Phone +61 3 9360-6400  
Fax +61 3 9360-6464  
sales@ebmpapst.com.au  
www.ebmpapst.com.au

 **New Zealand**  
ebm-papst A&NZ Pty Ltd.  
 Unit H, 61 Hugo Johnston Drive  
 1061 Penrose, Auckland  
NEW ZEALAND  
PO Box 112278,  
1642 Penrose, Auckland  
Phone +64 9 525-0245  
Fax +64 9 525-0246  
sales@ebmpapst.com.au  
www.ebmpapst.com.au







# Notes





**ebm-papst**  
**St. Georgen GmbH & Co. KG**

Hermann-Papst-Straße 1  
D-78112 St. Georgen  
Germany  
Phone +49 7724 81-0  
Fax +49 7724 81-1309  
info2@de.ebmpapst.com

**ebm-papst**  
**Mulfingen GmbH & Co. KG**

Bachmühle 2  
D-74673 Mulfingen  
Germany  
Phone +49 7938 81-0  
Fax +49 7938 81-110  
info1@de.ebmpapst.com

**ebm-papst**  
**Landshut GmbH**

Hofmark-Aich-Straße 25  
D-84030 Landshut  
Germany  
Phone +49 871 707-0  
Fax +49 871 707-465  
info3@de.ebmpapst.com

**ebmpapst**

The engineer's choice



Компания «ЭлектроПласт» предлагает заключение долгосрочных отношений при поставках импортных электронных компонентов на взаимовыгодных условиях!

Наши преимущества:

- Оперативные поставки широкого спектра электронных компонентов отечественного и импортного производства напрямую от производителей и с крупнейших мировых складов;
- Поставка более 17-ти миллионов наименований электронных компонентов;
- Поставка сложных, дефицитных, либо снятых с производства позиций;
- Оперативные сроки поставки под заказ (от 5 рабочих дней);
- Экспресс доставка в любую точку России;
- Техническая поддержка проекта, помощь в подборе аналогов, поставка прототипов;
- Система менеджмента качества сертифицирована по Международному стандарту ISO 9001;
- Лицензия ФСБ на осуществление работ с использованием сведений, составляющих государственную тайну;
- Поставка специализированных компонентов (Xilinx, Altera, Analog Devices, Intersil, Interpoint, Microsemi, Aeroflex, Peregrine, Syfer, Eurofarad, Texas Instrument, Miteq, Cobham, E2V, MA-COM, Hittite, Mini-Circuits, General Dynamics и др.);

Помимо этого, одним из направлений компании «ЭлектроПласт» является направление «Источники питания». Мы предлагаем Вам помощь Конструкторского отдела:

- Подбор оптимального решения, техническое обоснование при выборе компонента;
- Подбор аналогов;
- Консультации по применению компонента;
- Поставка образцов и прототипов;
- Техническая поддержка проекта;
- Защита от снятия компонента с производства.



#### Как с нами связаться

**Телефон:** 8 (812) 309 58 32 (многоканальный)

**Факс:** 8 (812) 320-02-42

**Электронная почта:** [org@eplast1.ru](mailto:org@eplast1.ru)

**Адрес:** 198099, г. Санкт-Петербург, ул. Калинина, дом 2, корпус 4, литера А.