

FND850-12DRG Front-End Preliminary Data Sheet

DC Input, 12V Output, 850 Watts



Features

- RoHS compliant for all six substances
- Universal input voltage range (36-75 VDC)
- High power density, 15.15 Watts/cubic inch
- 1U or 2U height configurations
- Droop current share with ORing FETs
- I²C interface status and control
- External standby voltage of 12 VDC @ 1 A
- Overtemperature, overload, and overvoltage protection
- Status LEDs: INPUT OK, OUTPUT OK, Overtemperature
- Airflow direction from rear-to-front

Applications

- Telecom, datacom, and distributed power systems

Description

The FND850-12DRG DC-DC front-end provides a 12 VDC output for telecom, datacom, and other distributed power applications. The FND850-12DRG small 1U by 2U size allows for configurations of either height in hot-swap redundant systems while its internal fan and cooling design permits wide use with reliable operation.

Status is provided with front panel LEDs, logic signals, and via the I²C management interface bus. In addition, the I²C bus can enable the power supply, control fan speed, and adjust the output voltage from 7 to 12 VDC. This powerful feature allows the same power supply to be used in various applications.

In addition, the FND850-12DRG is designed with airflow from the rear of the power supply to the front. This airflow direction supports those critical applications where space limitations and/or higher ambient temperatures near the rear of the racking system, prohibit the discharge of higher temperature airflow from regular front-to-rear cooled power supplies.

The FND850-12DRG meets international safety requirements and is CE marked to the Low Voltage Directive (LVD).

Model Selection

Model	Input Voltage (VDC)	Nominal Output Voltage (VDC)	Adjustment Range (VDC)	Maximum Output Current (Amps)	Line Regulation (%) ¹	Load Regulation (%) ^{1,2}	Ripple & Noise pk-pk (%) ³
FND850-12DRG	36 to 44	12	7 to 12.3	58	±0.17	6	1
	44 to 75	12	7 to 12.3	71	±0.17	6	1
	36 to 75	12 (Standby)	N/A	1	±5	±5	1

¹ % of Vnom

² Main 12 V output has built-in droop regulation.

³ Maximum peak-to-peak noise is expressed as a percentage of output voltage; 20 MHz bandwidth.

Input Specifications

Parameter	Conditions/Description	Min.	Nom.	Max.	Units
Input Voltage	DC input voltage	36		75	VDC
Hold-up Time	After DC input is removed at full power	4	5		ms
Input Current	At 100% load (main and standby output), Vin = 36 VDC			23.5	A rms
Inrush Surge Current	Internally limited. Vin = 36 VDC @ 25 °C			35	A pk
	Internally limited. Vin = 75 VDC @ 25 °C			25	



Output Specifications

Parameter	Conditions/Description	Min.	Nom.	Max.	Units
Efficiency	Full rated load at Vin = 36 to 75 VDC, Vout = 12V	84	88		%
	Full rated load at Vin = 36 to 75 VDC, Vout = 7V	80	82		
Minimum Load	Minimum loading required to maintain regulation.	0			A
Output Current	Main output: Vin = 36 to 44 VDC		58		A rms
	Main output: Vin = 44 to 75 VDC		71		
Nominal Output Power	12V output, Vin = 36 to 44 VDC			700	W
	12V output, Vin = 44 to 75 VDC			850	
	Standby output Vin = 36 to 75 VDC			12	
Overshoot	Output voltage overshoot at turn-on.			3	%
Transient Response	Maximum recovery time and deviation of initial set point due to a 50% load change, 1A/μs. Maximum recovery time: 12V output Maximum deviation: 12V output			1200 2 ¹	μs %
	Maximum recovery time and deviation of initial set point due to a 100% load change, 1A/μs. Maximum recovery time: 12V output Maximum deviation: 12V output			2 4 ¹	ms %
Turn-On Delay	Time required for initial output voltage stabilization after application of DC input.			2	Sec
Output Regulation	See Model Selection table on page 1.				

¹ Percentage value is based upon nominal output voltage. Does not include the voltage droop of 10 mV/1A (720 mV/71A)

Interface Signals and Internal Protection

Parameter	Conditions/Description	Min.	Nom.	Max.	Units
Overvoltage Protection	Latch-style overvoltage protection. Output adjusted to 12V: Output adjusted to 7V:	14.36 8.37		15.65 9.13	V
Overcurrent Protection ¹	Current limit. 12V output (Vin = 44 to 75V) 12V output (Vin = 36 to 44V) Standby output:	74 61 1.1	78 64 1.3	85 70 1.5	A
Short-Circuit Protection	Power supply to recover when short is removed.				
Overtemperature/ Fan Failure Warning ¹	<p>12V output will shut down in the event of an overtemperature condition or blocked fan rotor. Supply's fan and Vaux are active. Power supply will recover when OT condition is removed. Amber OT LED will turn ON to indicate fault condition.</p> <p>OT/Fan Fail is an open-collector signal with 20-mA pull-down. High signal indicates a normal operating condition. Output will go low at least 100 ms before OT condition shuts down the power supply. An amber light indicates fan failure.</p>				
DC OK ¹	TTL open-collector signal with active 20-mA pull-down. Represents percent of nominal set output voltage where signal is OK. Outside of this percentage, a signal high condition indicates an output which is out of tolerance. Green DC OK LED on front panel indicates normal operation.	90		110	%
Input Power Fail Warning ¹	TTL open-collector signal with active 20-mA pull-down. High indicates an input power fail (outside 36-75 VDC). Power Fail Warning will turn OFF green INPUT OK LED. Represents the time after warning signal before Vout drops to 95% due to loss of input power.	4			ms
Power Supply Present Signal ¹	Resistance of connection to logic ground which allows user to determine if power supply is present.		10		Ω
Current Share	Main output only. Difference in current between two supplies ($I\Delta < 5\%$ Isum - nom)			7.1	A
Remote Sense	Total voltage compensation for cable losses with respect to the main output.			0.5	V
Output Enable	Open circuit or logic high from ENA pin to Vo1 RTN shuts OFF Vo1; Vaux and fan are operational. Logic low (2 mA sink capability) or jumper will turn ON Vo1 within 100 ms. Open circuit voltage on enable pin is 3.3 VDC. Externally applied voltage to the enable pin should NOT exceed 7 VDC. Signal is referred to as Logic Return (LRTN).				

¹ Also available on I²C data line.



I²C Bus Management Interface

Detailed I²C information is available from the model's I²C Manual located on the Power-One web site.

Static	Includes static information such as: part number and revision level, output rating, serial number, date code, and manufacturing location.		
Status (Logic 1 or 0)	Power Supply OK. Input OK. DC Output OK. Power Supply Seated. Overtemperature. Overcurrent. Fan OK.		
Real-Time Monitoring	Output voltage (main output) 0.01V LSD. Output current (main output) 0.1A LSD.		
I ² C monitor signal accuracy at 25°C	Output voltage measurement (main output) ± 0.05 Output current measurement (main output) ± 1		V A
Control Signals (Logic 1 or 0)	Enable for main output. Fan speed level.		
I ² C setting	Output voltage setting resolution (main output) 0.0154 Output current setting resolution (main output) 0.5		V A

Safety, Regulatory, and EMI Specifications

Parameter	Conditions/Description	Min.	Nom.	Max.	Units
Agency Approvals	UL60950-1, (UL) CSA 60950-1 (cUL), EN60950-1, CE Mark for LVD.				
Electromagnetic Interference	FCC CFR title 47 Part 15 Sub-Part B, EN55022/ CISPR 22 Conducted: Radiated:	Level B Level A			
Voltage Fluctuation	Unit must start up	Pass			
ESD Susceptability	Per EN61000-4-2, Level 4. contact	8		.	kV
	Per EN61000-4-2, Level 4. air	15			kV
Radiated Susceptability	Per EN 61000-4-3, Level 3.	10		.	V/m
EFT/Burst	Per EN 61000-4-4, Level 4.	± 2		.	kV
Input Transient Protection	Per EN 61000-4-5, Level 1. Line-to-Line: Line-to-Ground:	± 0.5 ± 0.5		.	kV
RF Conducted Disturbances	Per EN 61000-4-6, Level 3.	10		.	V/m
Leakage Current	Per EN60950-1. Vin = 36 to 75 VDC:			3.5	mA



Environmental Specifications

Parameter	Conditions/Description	Min.	Nom.	Max.	Units
Altitude	Operating. Non-Operating.			10K 40K	ASL ft
Operating Temperature	Internal DC fan for cooling. At 100% load: ¹ At 50% load:	0 0		50 70	°C
Storage Temperature		-40		85	°C
Temperature Coefficient	0 °C to 70 °C (after 15-minute warm-up).			0.02	%/°C
Relative Humidity	Non-condensing (operational)			90	%RH
	Non-condensing (non operational)			95	%RH
Shock	Operating: half-sine, 10 ms, 3-axis.			+20	Gpk
	Non-Operating: half-sine, 10 ms, 3-axis.			+40	
Vibration	Operating: swept sine 5-2000-5 Hz, 5-32 Hz, 0.02iDA, 32-2000 Hz.			1	Gpk
	Non-operating: random 10-2000 Hz.			6.16	Grms

¹ At temperatures over 50°C – linear power derating to 50% of rated load up to 70°C

Reliability

Parameter	Conditions/Description	Min.	Nom.	Max.	Units
MTBF	Calculated per MILHDBK 217F Ground Benign at 25 °C. (does not include fan)	100 000			hrs
Useful Life	Based on fan life at 50 °C.	7			yrs

Mechanical Drawings

FRONT VIEW

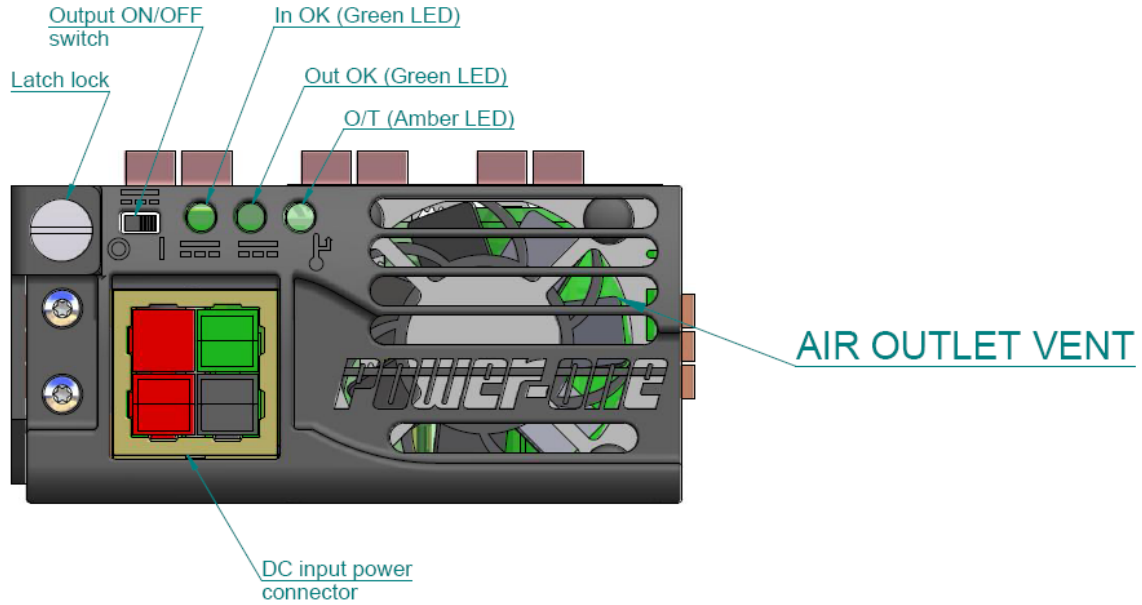

REAR VIEW

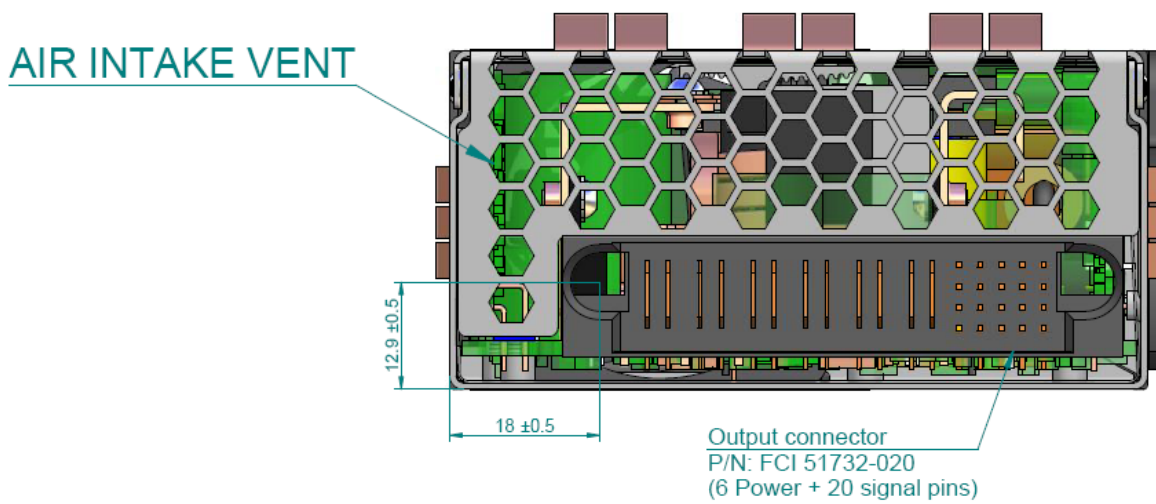

TOP VIEW

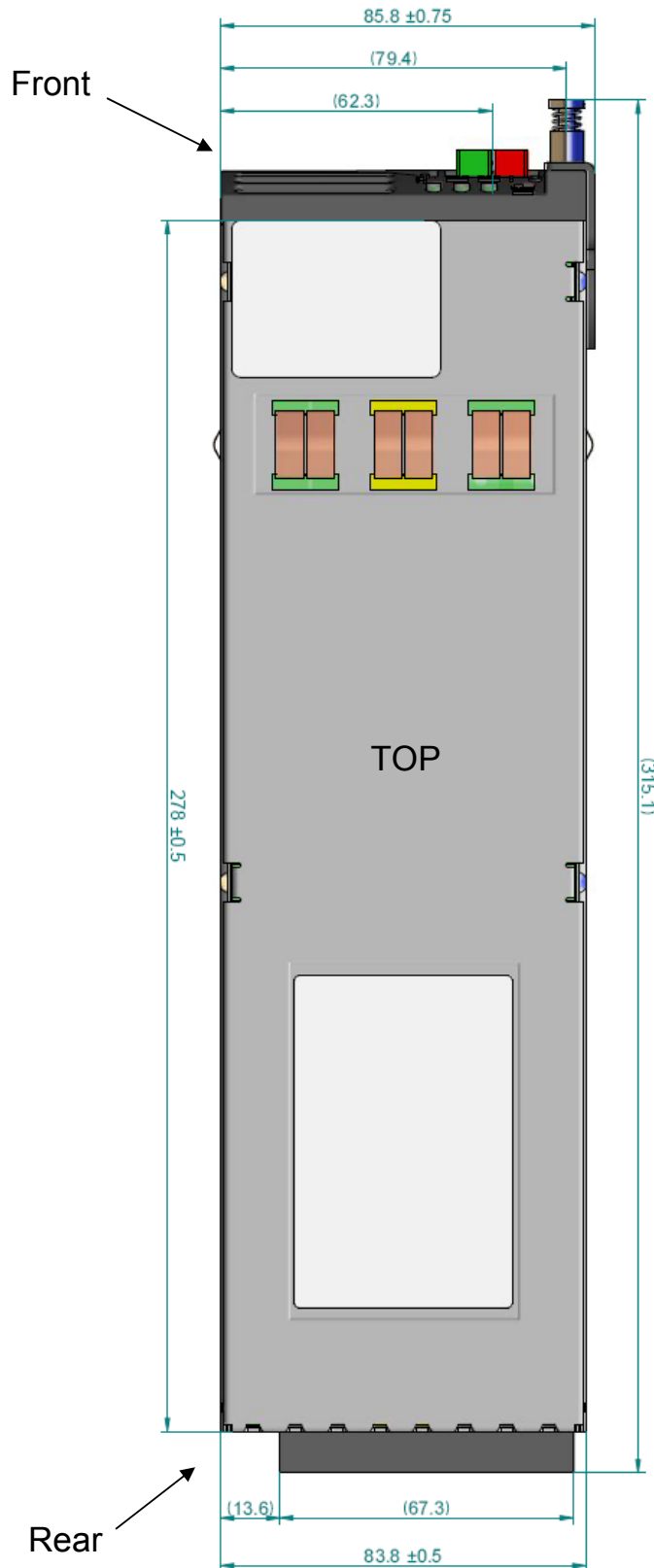

FND850-12DRG SIDE VIEW

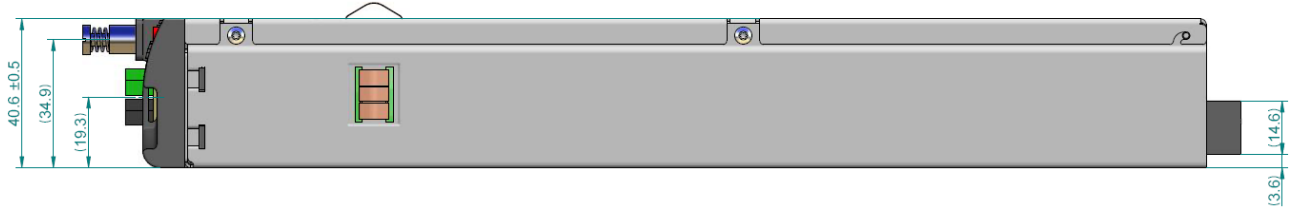

Connector Information

Power Supply:

Input - Anderson Power Products (APP): PP45 Powerpole Connector family
Output – FCI Power Blade family connector: P/N 51732-020LF

Mating Connections:

Input – Anderson Power connector: PP45 Powerpole Connector family
45A crimp contact AWG# 10/14 3x: P/N 261G2-LPBK
Flexible Conduit Hardware Pak 1x: P/N 110G10
Housing red 1x: P/N 1327
Housing green 1x: P/N 1327G5
Housing black 1x: P/N 1327G6
Red long spacer 1x: P/N 1399G2

Output – FCI Power Blade family connector: P/N: 51742-10602000AALF (Backplane – straight pins)
FCI Power Blade family connector: P/N: 51762-10602000AALF (Right Angle)

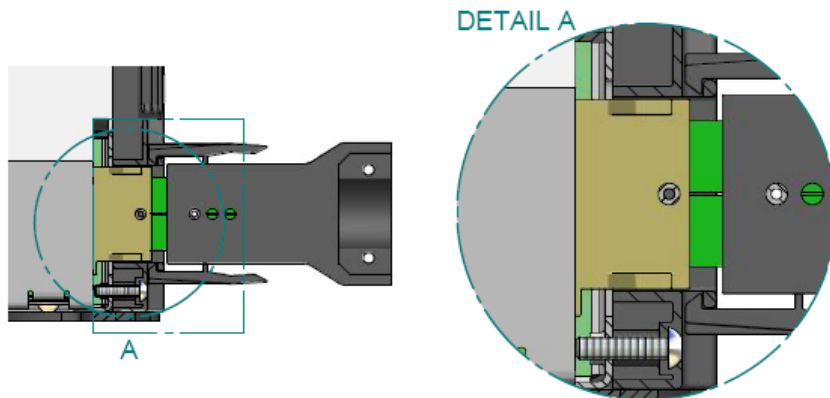
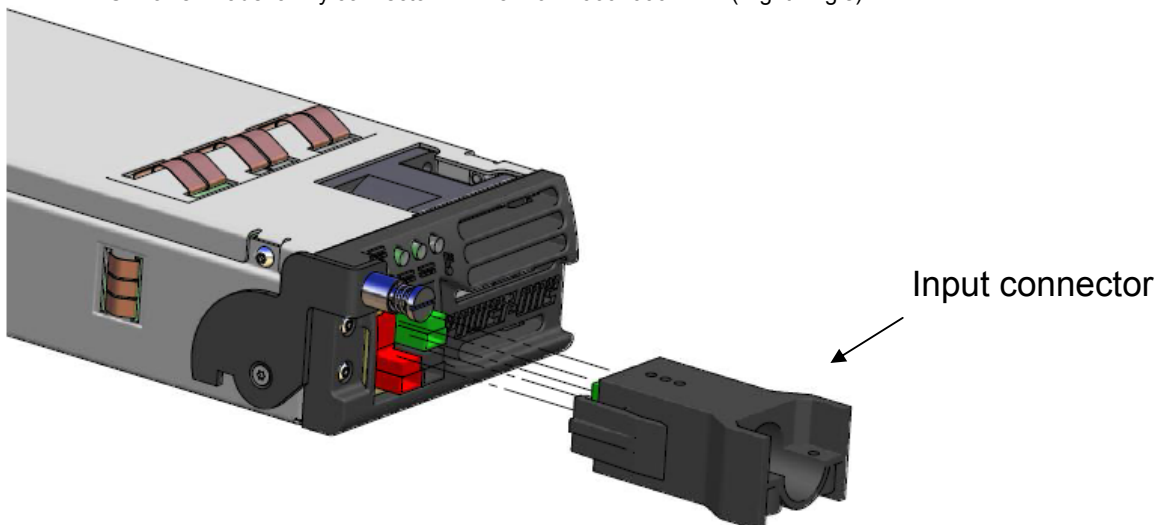



Input	Location
Chassis (Safety/EMI) Ground	Green
+ DC input voltage	Red
- DC input voltage	Black

Output Connector Pin Assignments

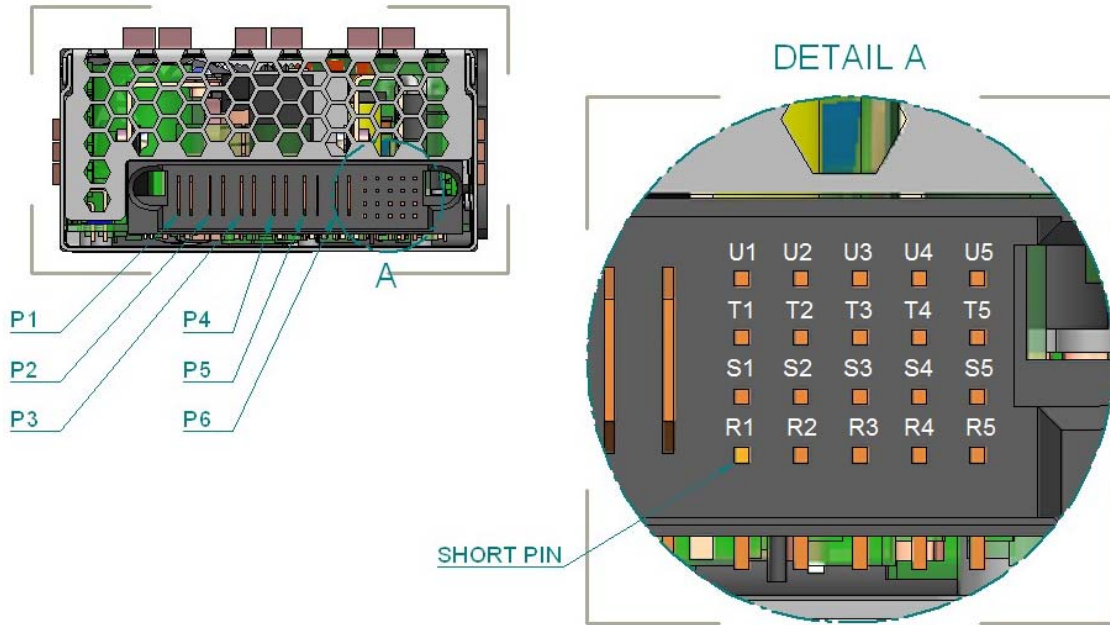

FND850-12DRG Signal/Pin/Ground Reference Information

Signal	Pin Location	Ground Reference
		LRTN (Logic Return) 10R resistor is internally connected to Aux Ground SRTN (Signal Return) is internally connected with Vout-
OverTemperature / Fan Fail	U1	Logic Ground (LRTN)
DC Input Fail Warning	U2	Logic Ground (LRTN)
Power Supply Present	U3	Logic Ground (LRTN)
Output Voltage Fault	U4	Logic Ground (LRTN)
Internal Ground	U5	Internal Ground (SRTN)
ADDR0, I ² C Address Bus	T1	Internal Ground (SRTN)
ADDR1, I ² C Address Bus	T2	Internal Ground (SRTN)
ADDR2, I ² C Address Bus	T3	Internal Ground (SRTN)
ADDR3, I ² C Address Bus	T4	Internal Ground (SRTN)
ADDR4, I ² C Address Bus	T5	Internal Ground (SRTN)
DATA, I ² C Data Line	S1	Logic Ground (LRTN)
CLOCK, I ² C Clock Line	S2	Logic Ground (LRTN)
Auxiliary Power +5V	S3	Aux Ground
Auxiliary Power Ground	S4	Aux Ground
Logic Ground	S5	Logic Ground (LRTN)
Output Enable ¹	R1	Logic Ground (LRTN)
Vsense+	R2	Vsense-
Vsense-	R3	Vsense-
Output Margin	R4	Internal Ground (SRTN)
Not Used	R5	
Vout+	P1, P2, P3	Vsense-
Vout-	P4, P5, P6	Vsense-

¹ Short pin length

FND850-12DRG locking system



DETAIL B

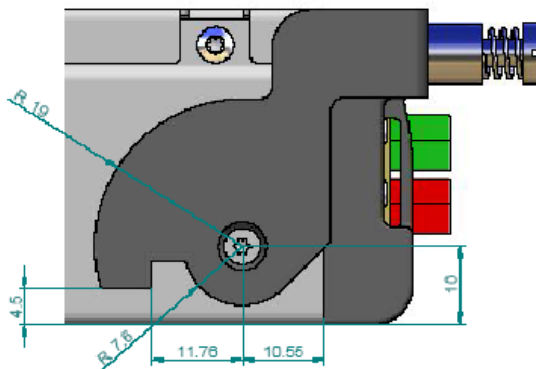

NUCLEAR AND MEDICAL APPLICATIONS - Power-One products are not designed, intended for use in, or authorized for use as critical components in life support systems, equipment used in hazardous environments, or nuclear control systems without the express written consent of the respective divisional president of Power-One, Inc.

TECHNICAL REVISIONS - The appearance of products, including safety agency certifications pictured on labels, may change depending on the date manufactured. Specifications are subject to change without notice.



Компания «ЭлектроПласт» предлагает заключение долгосрочных отношений при поставках импортных электронных компонентов на взаимовыгодных условиях!

Наши преимущества:

- Оперативные поставки широкого спектра электронных компонентов отечественного и импортного производства напрямую от производителей и с крупнейших мировых складов;
- Поставка более 17-ти миллионов наименований электронных компонентов;
- Поставка сложных, дефицитных, либо снятых с производства позиций;
- Оперативные сроки поставки под заказ (от 5 рабочих дней);
- Экспресс доставка в любую точку России;
- Техническая поддержка проекта, помощь в подборе аналогов, поставка прототипов;
- Система менеджмента качества сертифицирована по Международному стандарту ISO 9001;
- Лицензия ФСБ на осуществление работ с использованием сведений, составляющих государственную тайну;
- Поставка специализированных компонентов (Xilinx, Altera, Analog Devices, Intersil, Interpoint, Microsemi, Aeroflex, Peregrine, Syfer, Eurofarad, Texas Instrument, Miteq, Cobham, E2V, MA-COM, Hittite, Mini-Circuits, General Dynamics и др.);

Помимо этого, одним из направлений компании «ЭлектроПласт» является направление «Источники питания». Мы предлагаем Вам помощь Конструкторского отдела:

- Подбор оптимального решения, техническое обоснование при выборе компонента;
- Подбор аналогов;
- Консультации по применению компонента;
- Поставка образцов и прототипов;
- Техническая поддержка проекта;
- Защита от снятия компонента с производства.



Как с нами связаться

Телефон: 8 (812) 309 58 32 (многоканальный)

Факс: 8 (812) 320-02-42

Электронная почта: org@eplast1.ru

Адрес: 198099, г. Санкт-Петербург, ул. Калинина, дом 2, корпус 4, литера А.