



SEK 18 male low profile solder and press-in



General information

Design	IEC 60603-13		
No. of contacts	6,10,14,16,20,26,30,34,40,50,60,64		
Contact spacing	2,54 mm x 2,54 mm		
Test voltage Ur.ms	1 kV		
Working voltage	500 V for pollution degree 1		
Working current acc. to IEC 60512-2	See derating diagram		
Contact resistance	max. 20mOhm		
Insulation resistance	min. 10 ⁹ Ohm		
Temperature range	-55°C ... +125°C (solder) -55°C ... +105°C (press-in)		
Termination technology	solder, press-in		
Clearance & creepage distance	min. 0,5 mm clearance min. 0,56 creepage		
Insertion and withdrawal forces	6-pole max. 12N for PL1-2 / 18N for PL3	; 30-pole max. 60N for PL1-2 / 90N for PL3	
	10-pole max. 20N for PL1-2 / 30N for PL3	; 34-poles max. 68N for PL1-2 / 102N for PL3	
	14-pole max. 28N for PL1-2 / 42 for PL3	; 40-poles max. 80N for PL1-2 / 120N for PL3	
	16-pole max. 32N for PL1-2 / 48N for PL3	; 50-poles max. 100N for PL1-2 / 150N for PL3	
	20-pole max. 40N for PL1-2 / 60N for PL3	; 60-poles max. 120N for PL1-2 / 180N for PL3	
	26-pole max. 52N for PL1-2 / 78N for PL3	; 64-poles max. 128N for PL1-2 / 192N for PL3	
Mating cycles	S4 surface treatment	Au over PdNi (min. 0,76 µm)	
	PL 1 acc. to IEC 60603-13	500 mating cycles	10 days gas test
	PL 2 acc. to IEC 60603-13	250 mating cycles	4 days gas test
PL 3 acc. to IEC 60603-13	50 mating cycles	No gas test	
UL file	E 102079		
RoHS - compliant	Yes		
Leadfree	Yes		
Hot plugging	No		

Insulator material

Material	PBT (thermoplastics, glass fiber reinforcement 30%)		
Color	black (RAL 7001) or grey (RAL 7032) for solder grey (RAL 7053) for press-in		
UL classification	UL94-V0		
Material group acc. IEC 60664-1	IIIa (175 < CTI < 400)		
NF F 16-101 classification	I3,F3		

Contact material

Contact material	Copper alloy		
Plating termination zone	Sn over Ni for solder, Ni for press-in		
Plating contact sliding side	Au or Au over PdNi (according to performance level)		

Derating diagram acc to IEC 60512-2 (Current carrying capacity)

The current carrying capacity is limited by maximum temperature of materials for inserts and contacts including terminals. The current capacity-curve is valid for continuous, not interrupted current-loaded contacts of connectors when simultaneous power on all contacts is given without exceeding the maximum temperature. Control and test procedures according to DIN IEC 60512.

- 1) Temperature rise
- 2) Derating
- 3) Derating curve at I max x 0.8(IEC 60512-2)

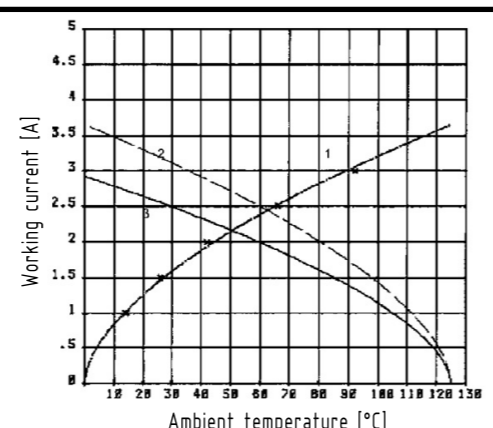

Recommended configuration of plated through holes for press-in termination

In addition to the hot-air-level (HAL), other PCB surfaces are getting more important. Due to their different properties - such as mechanical strength and coefficient of friction - we recommend the following configuration of PCB through holes.

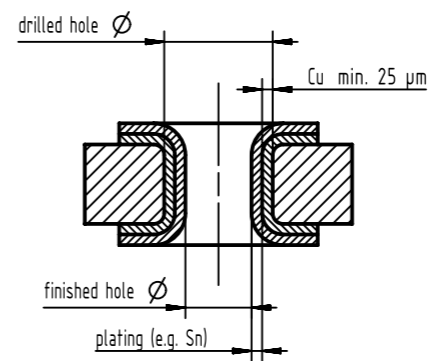

Tin plated PCB (HAL) acc. to EN 60352-5	Drilled hole Ø	1,15-0,03 mm
	Cu	min. 25 µm
	Sn	max. 15 µm
Chemical tin plated PCB	plated hole Ø	0,94 - 1,09 mm
	Drilled hole Ø	1,15-0,03 mm
	Cu	min. 25 µm
Gold /Nickel plated PCB	Sn	min. 0,8µm
	plated hole Ø	1,00 - 1,10 mm
	Drilled hole Ø	1,15-0,03 mm
	Cu	min. 25 µm
Silver plated PCB	Ni	3 - 7 µm
	Au	0,05 - 0,12 µm
	plated hole Ø	1,00 - 1,10 mm
	Drilled hole Ø	1,15-0,03 mm
Copper plated PCB (OSP)	Cu	min. 25 µm
	plated hole Ø	1,00 - 1,10 mm
	Drilled hole Ø	1,15-0,03 mm

Assembly instructions

It is highly recommended to use HARTING press-in tools to ensure a reliable press-in process. Please refer to the catalogue for tools, machines and further information about the press-in process.

Soldering instructions

The connectors should be protected when being soldered in a dip, flow or film soldering baths. Otherwise, they might become contaminated as a result of soldering operations or deformed as a result of overheating.

- (1) For prototypes and short runs protect the connectors with an industrial adhesive tape, e.g. Tesaband 4331 (www.tesa.de). Cover the underside of the connector moulding and the adjacent parts of the pcb as well as the open sides of the connector. This will prevent heat and gases of the soldering apparatus from damaging the connector. About 140 + 5 mm of the tape should suffice.
- (2) For large series a jig is recommended. Its protective cover with a fast action mechanical locking device shields the connectors from gas and heat generated by the soldering apparatus. As an additional protection a foil can be used for covering the parts that should not be soldered.

Packaging material (only for plastic tray)

Material	Polystyrol
Color	Yellow
Standardization	acc. to DIN EN / IEC 61340-5-1 and ANSI / ESD S541-2003

- Safe protection for electronic components against electrostatic charges

Cross section of solder terminations

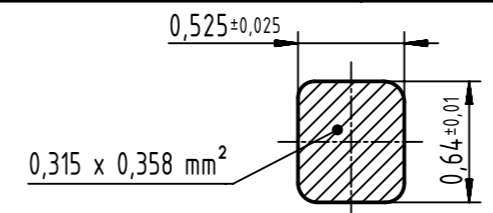

	All rights reserved Department EC PD - DE	All Dimensions in mm Original Size DIN A3	Scale 1:1	Free size tol.	Ref. Sub. DS 09181100001 / 500000101780 / 2016-07-25
	HARTING Electronics GmbH D-32339 Espelkamp	Created by STORCK	Inspected by LEHNERT	Standardisation HOFFMANN	Date 2016-09-05
Title SEK 18 male low profile solder and press-in					State Final Release
Type DS					Number 09181100001
Doc-Key / ECM-Nr. 100554984/UGD/001/F 500000107692					Rev. F
					Page 1/1

Mouser Electronics

Authorized Distributor

Click to View Pricing, Inventory, Delivery & Lifecycle Information:

HARTING:

[09185106321](#) [09185607321](#) [09185645919](#) [09185065322](#) [09185067323](#) [09185067324](#) [09185105322](#)
[09185105324](#) [09185106322](#) [09185106323](#) [09185106329](#) [09185106803](#) [09185107324](#) [09185145323](#) [09185146322](#)
[09185146324](#) [09185146803](#) [09185147324](#) [09185147329](#) [09185165322](#) [09185165323](#) [09185165329](#)
[09185166322](#) [09185166803](#) [09185166813](#) [09185167322](#) [09185167323](#) [09185167324](#) [09185205323](#) [09185206322](#)
[09185206323](#) [09185206329](#) [09185207322](#) [09185207323](#) [09185207324](#) [09185207329](#) [09185265323](#)
[09185265324](#) [09185265329](#) [09185266322](#) [09185266323](#) [09185266329](#) [09185267324](#) [09185345322](#) [09185345324](#)
[09185346322](#) [09185346323](#) [09185347324](#) [09185347329](#) [09185405329](#) [09185406322](#) [09185407322](#)
[09185407329](#) [09185505322](#) [09185506323](#) [09185506324](#) [09185507322](#) [09185507329](#) [09185507803](#) [09185509002](#)
[09185605323](#) [09185605324](#) [09185605329](#) [09185606322](#) [09185606324](#) [09185606329](#) [09185645323](#)
[09185646329](#) [09185647322](#) [09185647323](#) [09185647324](#) [09185066324](#) [09185106324](#) [09185266324](#) [09185067321](#)
[09185105321](#) [09185107321](#) [09185206321](#) [09185266321](#) [09185406321](#) [09185407321](#) [09185505321](#)
[09185506321](#) [09185507324](#) [09185407323](#) [09185146329](#) [09185065324](#) [09185107323](#) [09185166329](#) [09185146323](#)
[09185646323](#) [09185066323](#) [09185607324](#) [09185346329](#) [09185069002](#) [09185349002](#) [09185065329](#)
[09185105323](#) [09185147323](#) [09185166323](#)



Компания «ЭлектроПласт» предлагает заключение долгосрочных отношений при поставках импортных электронных компонентов на взаимовыгодных условиях!

Наши преимущества:

- Оперативные поставки широкого спектра электронных компонентов отечественного и импортного производства напрямую от производителей и с крупнейших мировых складов;
- Поставка более 17-ти миллионов наименований электронных компонентов;
- Поставка сложных, дефицитных, либо снятых с производства позиций;
- Оперативные сроки поставки под заказ (от 5 рабочих дней);
- Экспресс доставка в любую точку России;
- Техническая поддержка проекта, помощь в подборе аналогов, поставка прототипов;
- Система менеджмента качества сертифицирована по Международному стандарту ISO 9001;
- Лицензия ФСБ на осуществление работ с использованием сведений, составляющих государственную тайну;
- Поставка специализированных компонентов (Xilinx, Altera, Analog Devices, Intersil, Interpoint, Microsemi, Aeroflex, Peregrine, Syfer, Eurofarad, Texas Instrument, Miteq, Cobham, E2V, MA-COM, Hittite, Mini-Circuits, General Dynamics и др.);

Помимо этого, одним из направлений компании «ЭлектроПласт» является направление «Источники питания». Мы предлагаем Вам помощь Конструкторского отдела:

- Подбор оптимального решения, техническое обоснование при выборе компонента;
- Подбор аналогов;
- Консультации по применению компонента;
- Поставка образцов и прототипов;
- Техническая поддержка проекта;
- Защита от снятия компонента с производства.



Как с нами связаться

Телефон: 8 (812) 309 58 32 (многоканальный)

Факс: 8 (812) 320-02-42

Электронная почта: org@eplast1.ru

Адрес: 198099, г. Санкт-Петербург, ул. Калинина, дом 2, корпус 4, литера А.