

Series 79 Micro-Crimp Section H: Backshells and Accessories



799-016 EMI BACKSHELL FOR PANEL MOUNT CONNECTORS



Attach shield braid to panel-mounted connectors with 799-016 EMI adapters. These one-piece backshells attach to connector with stainless steel screws. These adapters feature an interlocking tongue that fits inside the connector for improved EMI shielding. Terminate shields with **BAND-IT™** stainless steel straps. Elliptical cable entry provides room for large wire bundles. These machined T6061 aluminum backshells are supplied with two mounting screws. These adapters fit 790-026 receptacles and 790-027 plugs.

Component	Material	Finish
Backshell	Aluminum Alloy	See table below
Hardware	Stainless Steel	Passivated

How To Order

Sample Part Number

799-016T M F 04 N 09

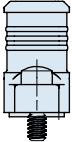
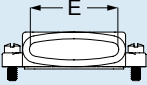
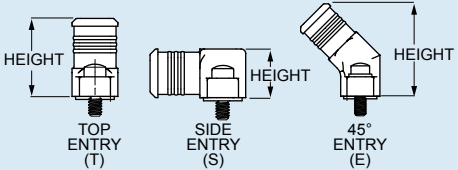
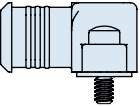
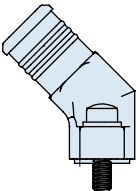
Part Number	Shell Finish	Shell Size	Cable Entry Size	Band Option	Height Code																																																																																															
 799-016T Top Entry	M Electroless Nickel <i>general purpose applications</i> MT Nickel-PTFE 1000 Hour Grey™ <i>maximum corrosion protection and durability (non-reflective grey)</i>	A B C D E F G H J K L	 Cable Entry Code E (In.) Shell Size 01 .255 A-L 02 .405 B-L 03 .555 C-L 04 .655 D-L 05 .805 E-L 06 .920 F-L 07 1.110 H-L 08 1.300 H-L 09 1.415 K, L 10 1.535 K, L 11 1.715 K	N No Band Supplied M BAND-IT™ Micro-Band Included. .125 (3.18) Wide.	 Entry Style Range <table border="1"> <thead> <tr> <th>Height Code</th> <th>Length (In.)</th> <th>Top Entry (T)</th> <th>Side Entry (S)</th> <th>45° Entry (E)</th> </tr> </thead> <tbody> <tr><td>05</td><td>.313</td><td>—</td><td>A-F, J, K</td><td>—</td></tr> <tr><td>06</td><td>.375</td><td>—</td><td>A-F, J, K</td><td>—</td></tr> <tr><td>07</td><td>.438</td><td>—</td><td>A-L</td><td>—</td></tr> <tr><td>08</td><td>.500</td><td>—</td><td>A-L</td><td>—</td></tr> <tr><td>09</td><td>.563</td><td>A-F, J, K</td><td>A-L</td><td>A-F, J, K</td></tr> <tr><td>10</td><td>.625</td><td>A-L</td><td>A-L</td><td>A-G, J, K</td></tr> <tr><td>11</td><td>.688</td><td>A-L</td><td>A-L</td><td>A-L</td></tr> <tr><td>12</td><td>.750</td><td>A-L</td><td>A-L</td><td>A-L</td></tr> <tr><td>13</td><td>.813</td><td>A-L</td><td>—</td><td>A-L</td></tr> <tr><td>14</td><td>.875</td><td>A-L</td><td>—</td><td>A-L</td></tr> <tr><td>15</td><td>.938</td><td>A-L</td><td>—</td><td>A-L</td></tr> <tr><td>16</td><td>1.000</td><td>A-L</td><td>—</td><td>A-L</td></tr> <tr><td>17</td><td>1.063</td><td>A-L</td><td>—</td><td>A-L</td></tr> <tr><td>18</td><td>1.125</td><td>A-L</td><td>—</td><td>G, H, L</td></tr> <tr><td>19</td><td>1.188</td><td>G, H, L</td><td>—</td><td>G, H, L</td></tr> <tr><td>20</td><td>1.250</td><td>G, H, L</td><td>—</td><td>G, H, L</td></tr> <tr><td>21</td><td>1.313</td><td>G, H, L</td><td>—</td><td>G, H, L</td></tr> <tr><td>22</td><td>1.375</td><td>G, H, L</td><td>—</td><td>—</td></tr> </tbody> </table>	Height Code	Length (In.)	Top Entry (T)	Side Entry (S)	45° Entry (E)	05	.313	—	A-F, J, K	—	06	.375	—	A-F, J, K	—	07	.438	—	A-L	—	08	.500	—	A-L	—	09	.563	A-F, J, K	A-L	A-F, J, K	10	.625	A-L	A-L	A-G, J, K	11	.688	A-L	A-L	A-L	12	.750	A-L	A-L	A-L	13	.813	A-L	—	A-L	14	.875	A-L	—	A-L	15	.938	A-L	—	A-L	16	1.000	A-L	—	A-L	17	1.063	A-L	—	A-L	18	1.125	A-L	—	G, H, L	19	1.188	G, H, L	—	G, H, L	20	1.250	G, H, L	—	G, H, L	21	1.313	G, H, L	—	G, H, L	22	1.375	G, H, L	—	—
						Height Code	Length (In.)	Top Entry (T)	Side Entry (S)	45° Entry (E)																																																																																										
05	.313	—	A-F, J, K	—																																																																																																
06	.375	—	A-F, J, K	—																																																																																																
07	.438	—	A-L	—																																																																																																
08	.500	—	A-L	—																																																																																																
09	.563	A-F, J, K	A-L	A-F, J, K																																																																																																
10	.625	A-L	A-L	A-G, J, K																																																																																																
11	.688	A-L	A-L	A-L																																																																																																
12	.750	A-L	A-L	A-L																																																																																																
13	.813	A-L	—	A-L																																																																																																
14	.875	A-L	—	A-L																																																																																																
15	.938	A-L	—	A-L																																																																																																
16	1.000	A-L	—	A-L																																																																																																
17	1.063	A-L	—	A-L																																																																																																
18	1.125	A-L	—	G, H, L																																																																																																
19	1.188	G, H, L	—	G, H, L																																																																																																
20	1.250	G, H, L	—	G, H, L																																																																																																
21	1.313	G, H, L	—	G, H, L																																																																																																
22	1.375	G, H, L	—	—																																																																																																
 799-016S Side Entry	ZNU Zinc-Nickel with Black Chromate <i>tactical applications (non-reflective black)</i> Additional shell finishes are listed on page C-9.	 799-016E 45° Entry																																																																																																		

Dimensions in inches (millimeters) and are subject to change without notice.

799-016 STYLE T - TOP ENTRY

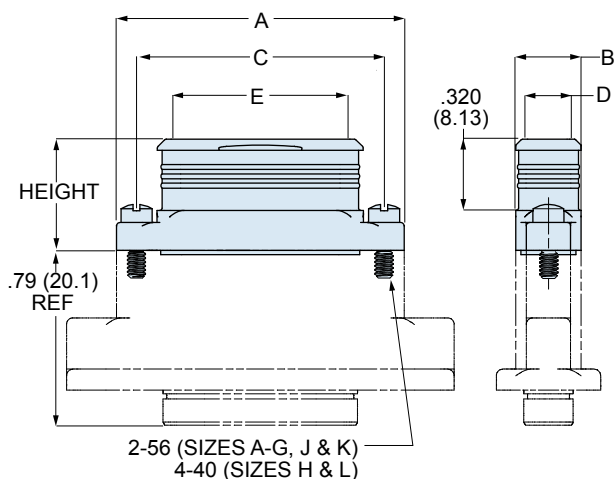

799-016 STYLE E - 45° ENTRY

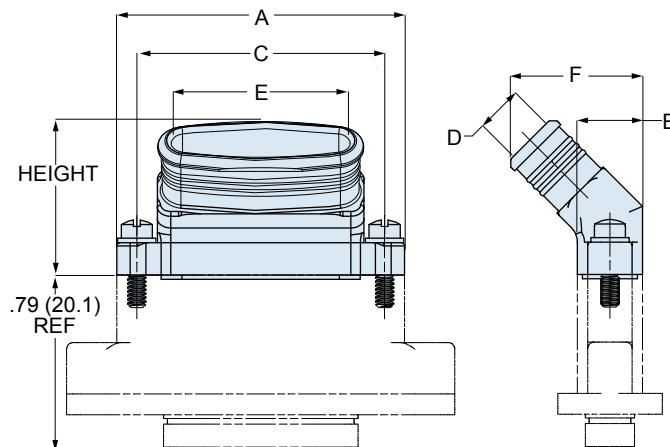

799-016 STYLE S - SIDE ENTRY

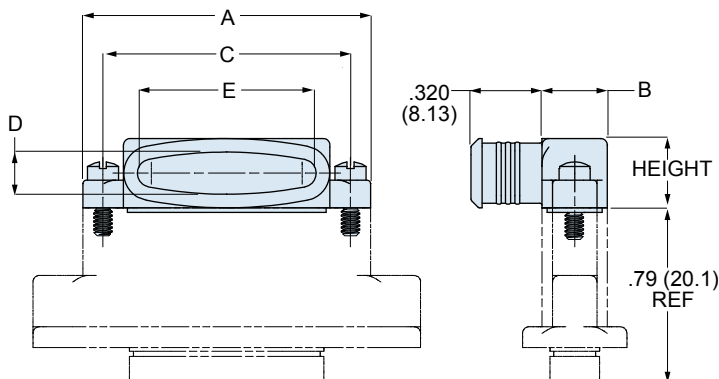

799-016 DIMENSIONS

Shell Size	A Max.		B Max.		C		D		F		Max. Entry Size
	In.	mm.	In.	mm.	In.	mm.	In.	mm.	In.	mm.	
A	.760	19.30	.308	7.82	.565	14.35	.190	4.83	.59	15.0	01
B	.910	23.11	.308	7.82	.715	18.16	.190	4.83	.59	15.0	02
C	1.060	26.92	.308	7.82	.865	21.97	.190	4.83	.59	15.0	03
D	1.160	29.46	.308	7.82	.965	24.51	.190	4.83	.59	15.0	04
E	1.310	33.27	.308	7.82	1.115	28.32	.190	4.83	.59	15.0	05
F	1.460	36.83	.308	7.82	1.265	32.13	.190	4.83	.59	15.0	06
G	1.410	35.81	.395	10.03	1.215	30.86	.275	6.99	.68	17.3	06
H	2.045	51.94	.410	10.41	1.800	45.72	.300	7.62	.70	17.8	08
J	1.810	45.97	.308	7.82	1.615	41.02	.190	4.83	.59	15.0	08
K	2.210	56.13	.308	7.82	2.015	51.18	.190	4.83	.59	15.0	11
L	2.281	57.94	.410	10.41	2.036	51.71	.300	7.62	.70	17.8	10

ENTRY SIZE

Code	E		Available Sizes
	In.	mm.	
01	.255	6.48	A thru L
02	.405	10.29	B thru L
03	.555	14.10	C thru L
04	.655	16.64	D thru L
05	.805	20.45	E thru L
06	.920	23.37	F thru L
07	1.110	28.19	H thru L
08	1.300	33.02	H thru L
09	1.415	35.94	K, L
10	1.535	38.99	K, L
11	1.715	43.56	K

Dimensions in inches (millimeters) and are subject to change without notice.

© 2009 Glenair, Inc.

CAGE Code 06324

Printed in U.S.A.

GLENAIR, INC. • 1211 AIR WAY • GLENDALE, CA 91201-2497 • 818-247-6000 • FAX 818-500-9912

www.glenair.com

H-6

E-Mail: sales@glenair.com

Rev. 04-July-2009



Компания «ЭлектроПласт» предлагает заключение долгосрочных отношений при поставках импортных электронных компонентов на взаимовыгодных условиях!

Наши преимущества:

- Оперативные поставки широкого спектра электронных компонентов отечественного и импортного производства напрямую от производителей и с крупнейших мировых складов;
- Поставка более 17-ти миллионов наименований электронных компонентов;
- Поставка сложных, дефицитных, либо снятых с производства позиций;
- Оперативные сроки поставки под заказ (от 5 рабочих дней);
- Экспресс доставка в любую точку России;
- Техническая поддержка проекта, помощь в подборе аналогов, поставка прототипов;
- Система менеджмента качества сертифицирована по Международному стандарту ISO 9001;
- Лицензия ФСБ на осуществление работ с использованием сведений, составляющих государственную тайну;
- Поставка специализированных компонентов (Xilinx, Altera, Analog Devices, Intersil, Interpoint, Microsemi, Aeroflex, Peregrine, Syfer, Eurofarad, Texas Instrument, Miteq, Cobham, E2V, MA-COM, Hittite, Mini-Circuits, General Dynamics и др.);

Помимо этого, одним из направлений компании «ЭлектроПласт» является направление «Источники питания». Мы предлагаем Вам помощь Конструкторского отдела:

- Подбор оптимального решения, техническое обоснование при выборе компонента;
- Подбор аналогов;
- Консультации по применению компонента;
- Поставка образцов и прототипов;
- Техническая поддержка проекта;
- Защита от снятия компонента с производства.



Как с нами связаться

Телефон: 8 (812) 309 58 32 (многоканальный)

Факс: 8 (812) 320-02-42

Электронная почта: org@eplast1.ru

Адрес: 198099, г. Санкт-Петербург, ул. Калинина, дом 2, корпус 4, литера А.