



(100A type)

RoHS compliant

### FEATURES

- Compact and high capacity using double contacts in series and permanent magnet installed. (1,000A/3 times) cut-off possible (EB Relay 100A type)
- Compact and lightweight for space savings and improved gas mileage.

### TYPICAL APPLICATIONS

Equipment requiring high capacity cutoff such as main power supplies for 42 V vehicles, motor assisters, quick recharging power supplies for AGVs (automatic guided vehicle), and motor controls for forklifts, etc.

## ORDERING INFORMATION

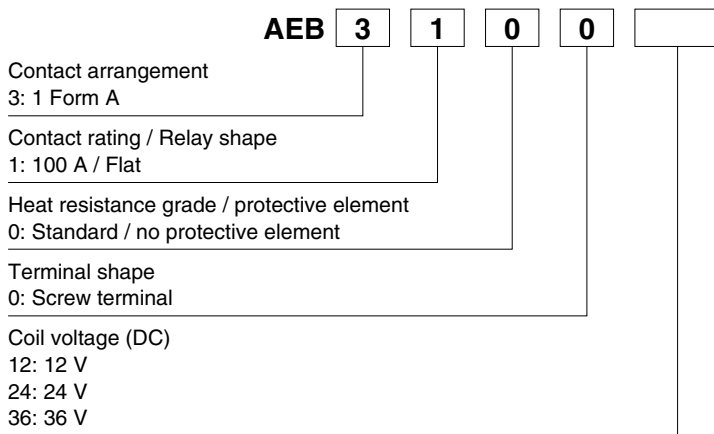

## TYPES

| Contact arrangement | Coil voltage | Protective construction | Terminal shape | Part No.  |
|---------------------|--------------|-------------------------|----------------|-----------|
| 1 Form A            | 12 V DC      | Dust cover              | Screw terminal | AEB310012 |
|                     | 24 V DC      |                         |                | AEB310024 |
|                     | 36 V DC      |                         |                | AEB310036 |

## RATING

### 1. Coil data

| Type  | Nominal coil voltage | Pick-up voltage (at 20°C 68°F) | Drop-out voltage (at 20°C 68°F) | Nominal operating current [±10%] (at 20°C 68°F) | Coil resistance [±10%] (at 20°C 68°F) | Nominal operating power (at 20°C 68°F) | Usable voltage range |
|-------|----------------------|--------------------------------|---------------------------------|---|---------------------------------------|--|----------------------|
| 100 A | 12V DC               | Max. 9.0 V DC                  | Min. 1.0 V DC                   | 410 mA  | 29.0Ω                                 | 5.0 W                                  | 10 to 16V DC         |
|       | 24V DC               | Max. 18.0 V DC                 | Min. 2.0 V DC                   | 208 mA  | 115Ω                                  | 5.0 W                                  | 20 to 32V DC         |
|       | 36V DC               | Max. 27.0 V DC                 | Min. 3.0 V DC                   | 139 mA  | 260Ω                                  | 5.0 W                                  | 30 to 48V DC         |

2. Specifications

| Characteristics            | Item  |                           | Specifications   |
|----------------------------|---|---------------------------|--|
| Contact rating             | Arrangement                                       |                           | 100 A type<br>1 Form A   |
|                            | Between terminal voltage drop (Initial)           |                           | Max. 0.15 V (at 100 A), Max. 0.05 V (at 10 A), Max. 0.01 V (at 1 A)  |
|                            | Contact material                                  |                           | Ag alloy (Cadmium free)  |
|                            | Nominal switching capacity (resistive load)       |                           | 100 A 42V DC   |
|                            | Max. carrying current                             |                           | 1,000A (0.1s)  |
|                            | Min. switching capacity (resistive load)*1        |                           | 1 A 12V DC   |
|                            | Max. cut-off current                              |                           | 1,000A 42V DC/3 cycle*3  |
|                            | Overload opening/closing rating                   |                           | 400A 55V DC/10 cycle   |
| Electrical characteristics | Insulation resistance (Initial)                   |                           | Min. 100 MΩ (at 500V DC)   |
|                            | Breakdown voltage (Initial)                       | Between open contacts     | 1,500 Vrms for 1 min.  |
|                            |   | Between contacts and coil | 2,500 Vrms for 1 min.  |
|                            | Operate time (at nominal voltage)                 |                           | Max. 30ms (at nominal coil voltage, excluding contact bounce time, at 20°C 68°F)   |
|                            | Release time (at nominal voltage)                 |                           | Max. 15ms (at nominal coil voltage, at 20°C 68°F)  |
| Mechanical characteristics | Shock resistance                                  | Functional                | Min. 196 m/s <sup>2</sup> {20.0G} (Half-wave pulse of sine wave: 11ms; detection time: 10μs)<br>(Nominal coil voltage applied to the coil) |
|                            |   | Destructive               | Min. 980 m/s <sup>2</sup> {100G} (Half-wave pulse of sine wave: 6ms)<br>(Nominal coil voltage applied to the coil or deenergized)          |
|                            | Vibration resistance                              | Functional                | 10 Hz to 500 Hz, Min. 44.1 m/s <sup>2</sup> {4.5G} (Nominal coil voltage applied to the coil)  |
|                            |   | Destructive               | 10 Hz to 200 Hz, Min. 44.1 m/s <sup>2</sup> {4.5G}, (Nominal coil voltage applied to the coil or deenergized)                              |
| Expected life              | Mechanical  |                           | Min. 10 <sup>6</sup>   |
|                            | Electrical  |                           | Min. 10 <sup>4</sup> (at 100 A 42V DC)<br>(resistive load, operating frequency: 1s ON, 9s OFF, room temperature)                           |
| Conditions                 | Conditions for operation, transport and storage*2 |                           | Ambient temperature: -40°C to +85°C -40°F to +185°F  |
| Mass                       |   |                           | Approx. 300 g 10.58 oz   |

Notes: \*1. This value can change due to the switching frequency, environmental conditions, and desired reliability level, therefore it is recommended to check this with the actual load.  
 \*2. The upper operation ambient temperature limit is the maximum temperature that can satisfy the coil temperature rise value. Please refer to "Usage ambient condition" in CAUTIONS FOR USE OF AUTOMOTIVE RELAYS.  
 \*3. Condition: Condition: Nominal switching 100cycles, each cut off 1,000A  
 \* When using a surge absorbing element for the relay coil drive circuit, please use with a surge absorbing element with a clamp voltage of "Rating voltage x1.5: 18V/36V/54V" or more. When the coil is connected in parallel with a diode, resistor or capacitor, the revert time will delay which might lead to degradation in shut-off performance and electrical working life.  
 Contact terminals have polarity; therefore, please obey the wiring diagram when connecting contacts.  
 The electrical load performance value applies when a varistor is connected in parallel with the coil.

REFERENCE DATA

1. Operate and release time characteristics

Sample: AEB310012  
 \*nominal coil voltage 12V type, 1pcs  
 Load: Coil applied voltage; 8.0 to 16.0V DC, coil surge protection elements; with zener diode (33V)  
 Ambient temperature: 25°C 77°F  
 Circuit:

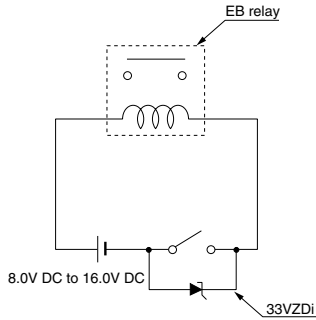

Coil applied voltage vs operate and release time

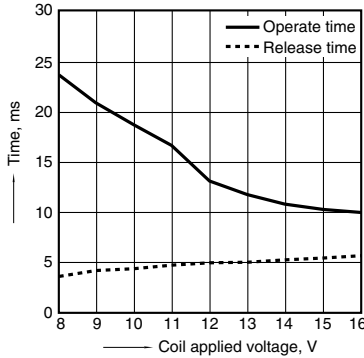

2. Ambient temperature characteristics (Cold start)

Sample: AEB310012  
 \*nominal coil voltage 12V type  
 5pcs

| Ambient temperature (°C) | -35 | 20  | 80  |
|--------------------------|-----|-----|-----|
| Standard value (V)       | —   | 9.0 | —   |
| Actual value (V)         | 5.4 | 6.7 | 8.3 |

Ambient temperature vs pick-up voltage (Cold start)

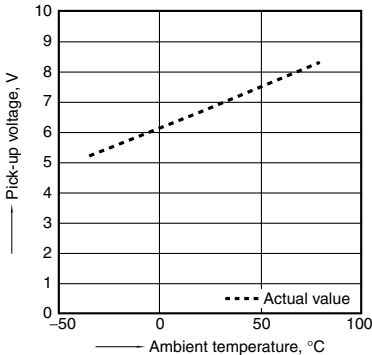

# EB (AEB)

## 3. Carrying current limit (error assumed)

Sample: AEB310012

\*nominal coil voltage 12V type

1pcs

Connection electric wire: 40mm<sup>2</sup>

Ambient temperature: 85°C 185°F

Standard for judgment: Relay contacts off when carrying finished.

## Carrying current and carrying time

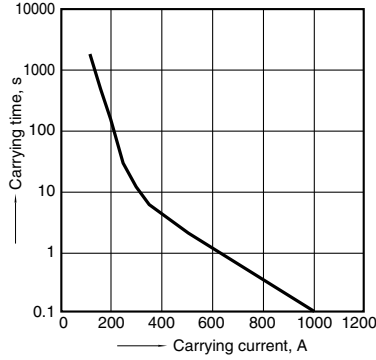

## 4. Cut-off characteristics

Sample: AEB310012

\*nominal coil voltage 12V type

2pcs

Load: Coil applied voltage; 14V DC

Ambient temperature: Room temperature

Max. cut-off current:

(1) 300A (42V DC: resistive load)

(2) 1,000A (42V DC: resistive load)

Operating cycle:

(1) 300A/10 cycles

(2) 1,000A/3 cycles

### (1) Cut off current/voltage: 300A/42V DC (resistive load)

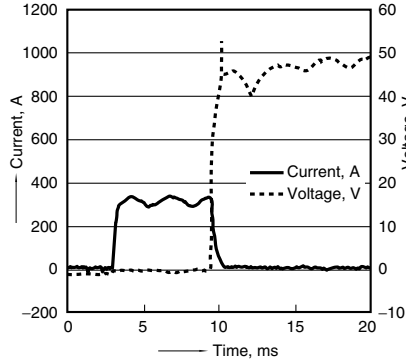

### (2) Cut off current/voltage: 1,000A/42V DC (resistive load)

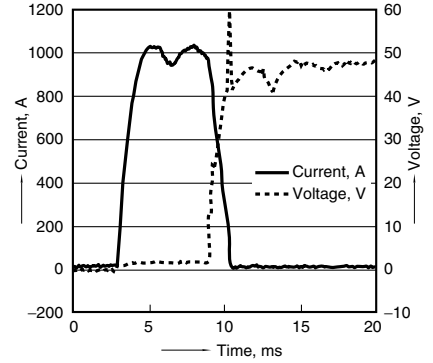

## DIMENSIONS (mm inch)

The CAD data of the products with a **CAD Data** mark can be downloaded from: <http://industrial.panasonic.com/ac/e>

### CAD Data

### External dimensions

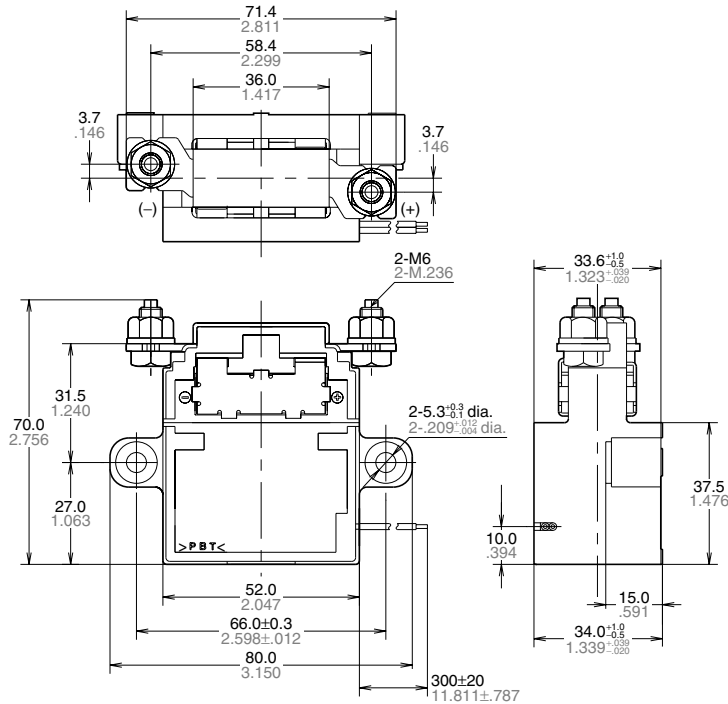

### Schematic (TOP VIEW)

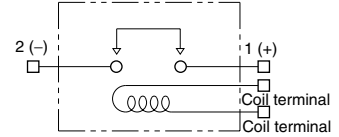

### Mounting hole pattern (TOP VIEW)

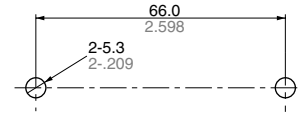

Tolerance: ±0.1 ±.004

### General tolerance:

less than 10 .394: ±0.3 ±.012

10 to 50 .394 to 1.969: ±0.6 ±.024

more than 50 1.969: ±1.0 ±.039

Notes: 1. Please be warned that contact terminals have polarity. There is no polarity in the coil input line.

2. We will make separate consideration if a coil lead wire connector is desired.

3. M6 tighten torque: 6.0 N·m to 8.0 N·m

## NOTES

1. For general cautions for use, please refer to the “CAUTIONS FOR USE OF AUTOMOTIVE RELAYS”.

2. To ensure proper operation, the voltage applied to the coil should be the rated operating voltage of the coil. Also, be aware that the pick-up and drop-out voltages will fluctuate depending on the ambient temperature and operating conditions.

3. Heat, smoke, and even a fire may occur if the relay is used in conditions outside of the allowable ranges for the coil ratings, contact ratings, operating cycle lifetime, and other specifications. Therefore, do not use the relay if these ratings are exceeded.

4. If the relay has been dropped, the appearance and characteristics should always be checked before use.

5. When using this relay for AC load switching, caution is required. Please contact us.

6. Make sure that the relay is wired correctly. Incorrect wiring may cause unexpected events or the generation of heat or flames.

7. We recommend you use a surge absorbing element with a clamp voltage of “Rating voltage x1.5: 18V/36V/54V” or more for the relay coil drive circuit as a means for relay coil surge absorption. Please avoid the use of diodes, capacitors and resistors because they lead to degradation in cut-off performance.

8. Avoid mounting the relay in strong magnetic fields (near a transformer or magnet) or close to an object that radiates heat.

### 9. Electrical life

This relay is a high-voltage direct-current switch. In its final breakdown mode, it may lose the ability to provide the proper cut-off. Therefore, do not exceed the indicated switching capacity and life. (Please treat the relay as a product with limited life and replace it when necessary.)

In the event that the relay loses cut-off ability, there is a possibility that burning may spread to surrounding parts, so configure the layout so that the power is turned off within one second.

10. If the power is turned off and then immediately on after applying the rated voltage (current) continuously to the relay's coil and contact, the resistance of the coil will increase due to a rise in the coil temperature. This causes the pick-up voltage to rise, and possibly exceed the rated pick-up voltage. In these circumstances, take measures such as reducing the load current, limiting the duration of current flow, and applying a coil voltage higher than the rated operating voltage (quick start).

11. If you are using an inductive load (L load) such that  $L/R > 1$  ms, add surge protection in parallel with the inductive load. If this is not done, the electrical life will decrease and cut-off failure may occur.

12. Be careful that foreign matter and oils and fats kind doesn't stick to the main terminal part because it is likely to cause a terminal part to give off unusual heat.

13. Avoid excessive load applied to the terminal in case of installing such as a bus bar etc., because it might give bad influence to the opening and closing performance.

Tighten each of the screws within the rated ranges given below.

Main terminal (M6 screw):

6.0N·m to 8.0N·m

Main unit mounting (M5 screw):

2.5N·m to 3.6N·m

### 14. Usage, transport and storage conditions

Ambient temperature, humidity, and atmospheric pressure during usage, transport, and storage of the relay:

1) Temperature:  $-40$  to  $+85^{\circ}\text{C}$   $-40$  to  $+185^{\circ}\text{F}$

2) Humidity: 5 to 85% RH (Avoid freezing and condensation.)

3) Atmospheric pressure: 85 to 106 kPa  
Temperature and humidity range for usage, transport, and storage:

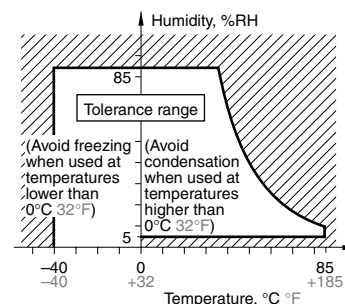

#### 4) Condensation

Condensation forms when there is a sudden change in temperature under high temperature and high humidity conditions. Condensation will cause deterioration of the relay insulation.

#### 5) Freezing

Condensation or other moisture may freeze on the relay when the temperatures is lower than  $0^{\circ}\text{C}$   $32^{\circ}\text{F}$ . This causes problems such as sticking of movable parts or operational time lags.

#### 6) Low temperature, low humidity environments

The plastic becomes brittle if the relay is exposed to a low temperature, low humidity environment for long periods of time.

**For Cautions for Use, see Relay Technical Information.**

# Mouser Electronics

Authorized Distributor

Click to View Pricing, Inventory, Delivery & Lifecycle Information:

[Panasonic:](#)

[AEB310012](#) [AEB310024](#)



Компания «ЭлектроПласт» предлагает заключение долгосрочных отношений при поставках импортных электронных компонентов на взаимовыгодных условиях!

Наши преимущества:

- Оперативные поставки широкого спектра электронных компонентов отечественного и импортного производства напрямую от производителей и с крупнейших мировых складов;
- Поставка более 17-ти миллионов наименований электронных компонентов;
- Поставка сложных, дефицитных, либо снятых с производства позиций;
- Оперативные сроки поставки под заказ (от 5 рабочих дней);
- Экспресс доставка в любую точку России;
- Техническая поддержка проекта, помощь в подборе аналогов, поставка прототипов;
- Система менеджмента качества сертифицирована по Международному стандарту ISO 9001;
- Лицензия ФСБ на осуществление работ с использованием сведений, составляющих государственную тайну;
- Поставка специализированных компонентов (Xilinx, Altera, Analog Devices, Intersil, Interpoint, Microsemi, Aeroflex, Peregrine, Syfer, Eurofarad, Texas Instrument, Miteq, Cobham, E2V, MA-COM, Hittite, Mini-Circuits, General Dynamics и др.);

Помимо этого, одним из направлений компании «ЭлектроПласт» является направление «Источники питания». Мы предлагаем Вам помощь Конструкторского отдела:

- Подбор оптимального решения, техническое обоснование при выборе компонента;
- Подбор аналогов;
- Консультации по применению компонента;
- Поставка образцов и прототипов;
- Техническая поддержка проекта;
- Защита от снятия компонента с производства.



#### Как с нами связаться

**Телефон:** 8 (812) 309 58 32 (многоканальный)

**Факс:** 8 (812) 320-02-42

**Электронная почта:** [org@eplast1.ru](mailto:org@eplast1.ru)

**Адрес:** 198099, г. Санкт-Петербург, ул. Калинина, дом 2, корпус 4, литера А.