

FEATURES

Complete 16-Bit D/A Function
On-Chip Output Amplifier
High Stability Buried Zener Reference
Monolithic BiMOS II Construction
 ± 1 LSB Integral Linearity Error
15-Bit Monotonic over Temperature
Microprocessor Compatible
16-Bit Parallel Input
Double-Buffered Latches
Fast 40 ns Write Pulse
Unipolar or Bipolar Output
Low Glitch: 15 nV-s
Low THD+N: 0.009%
MIL-STD-883 Compliant Versions Available

GENERAL DESCRIPTION

The AD669 DACPORT[®] is a complete 16-bit monolithic D/A converter with an on-board reference and output amplifier. It is manufactured on Analog Devices' BiMOS II process. This process allows the fabrication of low power CMOS logic functions on the same chip as high precision bipolar linear circuitry. The AD669 chip includes current switches, decoding logic, an output amplifier, a buried Zener reference and double-buffered latches.

The AD669's architecture insures 15-bit monotonicity over temperature. Integral nonlinearity is maintained at $\pm 0.003\%$, while differential nonlinearity is $\pm 0.003\%$ max. The on-chip output amplifier provides a voltage output settling time of 10 μ s to within 1/2 LSB for a full-scale step.

Data is loaded into the AD669 in a parallel 16-bit format. The double-buffered latch structure eliminates data skew errors and provides for simultaneous updating of DACs in a multi-DAC system. Three TTL/LSTTL/5 V CMOS compatible signals control the latches: \overline{CS} , \overline{LI} and LDAC.

The output range of the AD669 is pin programmable and can be set to provide a unipolar output range of 0 V to +10 V or a bipolar output range of -10 V to +10 V.

The AD669 is available in seven grades: AN and BN versions are specified from -40°C to +85°C and are packaged in a 28-pin plastic DIP. The AR and BR versions are specified for -40°C to +85°C operation and are packaged in a 28-pin SOIC. The SQ version is specified from -55°C to +125°C and is packaged in a hermetic 28-pin cerdip package. The AD669 is also available compliant to MIL-STD-883. Refer to the AD669/883B data sheet for specifications and test conditions.

DACPORT is a registered trademark of Analog Devices, Inc.

REV. A

Information furnished by Analog Devices is believed to be accurate and reliable. However, no responsibility is assumed by Analog Devices for its use, nor for any infringements of patents or other rights of third parties which may result from its use. No license is granted by implication or otherwise under any patent or patent rights of Analog Devices.

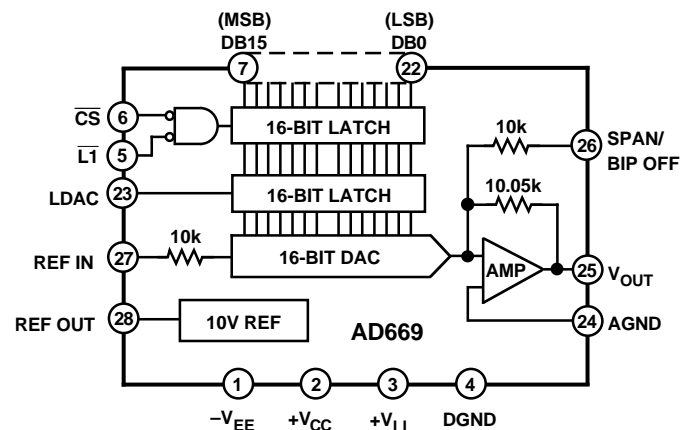
FUNCTIONAL BLOCK DIAGRAM

PRODUCT HIGHLIGHTS

1. The AD669 is a complete voltage output 16-bit DAC with voltage reference and digital latches on a single IC chip.
2. The internal buried Zener reference is laser trimmed to 10.000 volts with a $\pm 0.2\%$ maximum error. The reference voltage is also available for external applications.
3. The AD669 is both dc and ac specified. DC specs include ± 1 LSB INL error and ± 1 LSB DNL error. AC specs include 0.009% THD+ N and 83 dB SNR. The ac specifications make the AD669 suitable for signal generation applications.
4. The double-buffered latches on the AD669 eliminate data skew errors while allowing simultaneous updating of DACs in multi-DAC systems.
5. The output range is a pin-programmable unipolar 0 V to +10 V or bipolar -10 V to +10 V output. No external components are necessary to set the desired output range.
6. The AD669 is available in versions compliant with MIL-STD-883. Refer to the Analog Devices Military Products Databook or current AD669/883B data sheet for detailed specifications.

AD669—SPECIFICATIONS (@ $T_A = +25^\circ\text{C}$, $V_{CC} = +15\text{ V}$, $V_{EE} = -15\text{ V}$, $V_{LL} = +5\text{ V}$, unless otherwise noted)

| Model | AD669AN/AR | | | AD669AQ/SQ | | | AD669BN/BQ/BR | | | Units |
|---|--------------|-------|--------------|------------|-----|------------|---------------|-----|---------------|-----------------------|
| | Min | Typ | Max | Min | Typ | Max | Min | Typ | Max | |
| RESOLUTION | 16 | | | 16 | | | 16 | | | Bits |
| DIGITAL INPUTS (T_{MIN} to T_{MAX}) | | | | | | | | | | |
| V_{IH} (Logic "1") | 2.0 | | 5.5 | * | * | | * | * | | Volts |
| V_{IL} (Logic "0") | 0 | | 0.8 | * | * | | * | * | | Volts |
| I_{IH} ($V_{IH} = 5.5\text{ V}$) | | | ± 10 | | | * | | | μA | |
| I_{IL} ($V_{IL} = 0\text{ V}$) | | | ± 10 | | | * | | | μA | |
| TRANSFER FUNCTION CHARACTERISTICS ¹ | | | | | | | | | | |
| Integral Nonlinearity | | | ± 2 | | | * | | | ± 1 | LSB |
| T_{MIN} to T_{MAX} | | | ± 4 | | | * | | | ± 2 | LSB |
| Differential Nonlinearity | | | ± 2 | | | * | | | ± 1 | LSB |
| T_{MIN} to T_{MAX} | | | ± 4 | | | * | | | ± 2 | LSB |
| Monotonicity Over Temperature | 14 | | | 14 | | | 15 | | | Bits |
| Gain Error ^{2, 5} | | | ± 0.15 | | | ± 0.10 | | | ± 0.10 | % of FSR |
| Gain Drift ² (T_{MIN} to T_{MAX}) | | | 25 | | | 15 | | | 15 | ppm/ $^\circ\text{C}$ |
| Unipolar Offset | | | ± 5 | | | ± 5 | | | ± 2.5 | mV |
| Unipolar Offset Drift (T_{MIN} to T_{MAX}) | | | 5 | | | 3 | | | 3 | ppm/ $^\circ\text{C}$ |
| Bipolar Zero Error | | | ± 15 | | | ± 15 | | | ± 10 | mV |
| Bipolar Zero Error Drift (T_{MIN} to T_{MAX}) | | | 12 | | | 10 | | | 5 | ppm/ $^\circ\text{C}$ |
| REFERENCE INPUT | | | | | | | | | | |
| Input Resistance | 7 | 10 | 13 | * | * | * | * | * | * | k Ω |
| Bipolar Offset Input Resistance | 7 | 10 | 13 | * | * | * | * | * | * | k Ω |
| REFERENCE OUTPUT | | | | | | | | | | |
| Voltage | 9.98 | 10.00 | 10.02 | * | * | * | * | * | * | Volts |
| Drift | | | 25 | | | 15 | | | 15 | ppm/ $^\circ\text{C}$ |
| External Current ³ | 2 | 4 | | * | * | | * | * | | mA |
| Capacitive Load | | | 1000 | | | * | | | * | pF |
| Short Circuit Current | 25 | | | * | | | * | | | mA |
| OUTPUT CHARACTERISTICS | | | | | | | | | | |
| Output Voltage Range | | | | | | | | | | |
| Unipolar Configuration | 0 | +10 | | * | * | | * | * | | Volts |
| Bipolar Configuration | -10 | +10 | | * | * | | * | * | | Volts |
| Output Current | 5 | | | * | | | * | | | mA |
| Capacitive Load | | | 1000 | | | * | | | * | pF |
| Short Circuit Current | 25 | | | * | | | * | | | mA |
| POWER SUPPLIES | | | | | | | | | | |
| Voltage | | | | | | | | | | |
| V_{CC} ⁴ | +13.5 | | +16.5 | * | * | | * | * | | Volts |
| V_{EE} ⁴ | -13.5 | | -16.5 | * | * | | * | * | | Volts |
| V_{LL} | +4.5 | | +5.5 | * | * | | * | * | | Volts |
| Current (No Load) | | | | | | | | | | |
| I_{CC} | +12 | | +18 | * | | * | * | | * | mA |
| I_{EE} | -12 | | -18 | * | | * | * | | * | mA |
| I_{LL} | | | | * | | * | * | | * | mA |
| @ V_{IH} , $V_{IL} = 5, 0\text{ V}$ | 0.3 | | 2 | * | | * | * | | * | mA |
| @ V_{IH} , $V_{IL} = 2.4, 0.4\text{ V}$ | 3 | | 7.5 | * | | * | * | | * | mA |
| Power Supply Sensitivity | 1 | | 3 | * | | * | * | | * | ppm/% |
| Power Dissipation (Static, No Load) | 365 | | 625 | * | | | * | | | mW |
| TEMPERATURE RANGE | | | | | | | | | | |
| Specified Performance (A, B) | -40 | | +85 | -40 | | +85 | -40 | | +85 | $^\circ\text{C}$ |
| Specified Performance (S) | | | | -55 | | +125 | | | | $^\circ\text{C}$ |

NOTES

¹For 16-bit resolution, 1 LSB = 0.0015% of FSR = 15 ppm of FSR. For 15-bit resolution, 1 LSB = 0.003% of FSR = 30 ppm of FSR. For 14-bit resolution 1 LSB = 0.006% of FSR = 60 ppm of FSR. FSR stands for Full-Scale Range and is 10 V for a 0 V to +10 V span and 20 V for a -10 V to +10 V span.

²Gain error and gain drift measured using the internal reference. Gain drift is primarily reference related. See the Using the AD669 with the AD688 Reference section for further information.

³External current is defined as the current available in addition to that supplied to REF IN and SPAN/BIPOLAR OFFSET on the AD669.

⁴Operation on $\pm 12\text{ V}$ supplies is possible using an external reference like the AD586 and reducing the output range. Refer to the Internal/External Reference Use section.

⁵Measured with fixed 50 Ω resistors. Eliminating these resistors increases the gain error by 0.25% of FSR (Unipolar mode) or 0.50% of FSR (Bipolar mode). Refer to the Analog Circuit Connections section.

*Same as AD669AN/AR specification.

Specifications subject to change without notice.

Specifications in **boldface** are tested on all production units at final electrical test. Results from those tests are used to calculate outgoing quality levels. All min and max specifications are guaranteed. Those shown in boldface are tested on all production units.

AC PERFORMANCE CHARACTERISTICS

(With the exception of Total Harmonic Distortion + Noise and Signal-to-Noise Ratio, these characteristics are included for design guidance only and are not subject to test. THD+N and SNR are 100% tested.)

$T_{MIN} \leq T_A \leq T_{MAX}$, $V_{CC} = +15\text{ V}$, $V_{EE} = -15\text{ V}$, $V_{LL} = +5\text{ V}$ except where noted.)

| Parameter | Limit | Units | Test Conditions/Comments |
|---|--------------------------------|--|---|
| Output Settling Time (Time to $\pm 0.0008\%$ FS with 2 k Ω , 1000 pF Load) | 13 8 10 6 8 2.5 | μs max μs typ μs typ μs typ μs typ μs typ | 20 V Step, $T_A = +25^\circ\text{C}$ 20 V Step, $T_A = +25^\circ\text{C}$ 20 V Step, $T_{MIN} \leq T_A \leq T_{MAX}$ 10 V Step, $T_A = +25^\circ\text{C}$ 10 V Step, $T_{MIN} \leq T_A \leq T_{MAX}$ 1 LSB Step, $T_{MIN} \leq T_A \leq T_{MAX}$ |
| Total Harmonic Distortion + Noise A, B, S Grade | 0.009 | % max | 0 dB, 1001 Hz; Sample Rate = 100 kHz; $T_A = +25^\circ\text{C}$ |
| A, B, S Grade | 0.07 | % max | -20 dB, 1001 Hz; Sample Rate = 100 kHz; $T_A = +25^\circ\text{C}$ |
| A, B, S Grade | 7.0 | % max | -60 dB, 1001 Hz; Sample Rate = 100 kHz; $T_A = +25^\circ\text{C}$ |
| Signal-to-Noise Ratio | 83 | dB min | $T_A = +25^\circ\text{C}$ |
| Digital-to-Analog Glitch Impulse | 15 | nV-s typ | DAC Alternately Loaded with 8000H and 7FFFH |
| Digital Feedthrough | 2 | nV-s typ | DAC Alternately Loaded with 0000H and FFFFH; $\overline{\text{CS}}$ High |
| Output Noise Voltage Density (1 kHz – 1 MHz) | 120 | nV/ $\sqrt{\text{Hz}}$ typ | Measured at V_{OUT} , 20 V Span; Excludes Reference |
| Reference Noise | 125 | nV/ $\sqrt{\text{Hz}}$ typ | Measured at REF OUT |

Specifications subject to change without notice.

Specifications in **boldface** are tested on all production units at final electrical test. Results from those tests are used to calculate outgoing quality levels. All min and max specifications are guaranteed. Those shown in boldface are tested on all production units.

TIMING CHARACTERISTICS

$V_{CC} = +15\text{ V}$, $V_{EE} = -15\text{ V}$, $V_{LL} = +5\text{ V}$, $V_{HI} = 2.4\text{ V}$, $V_{LO} = 0.4\text{ V}$

| Parameter | Limit +25°C | Limit -40°C to +85°C | Limit -55°C to +125°C | Units |
|----------------------------|-----------------------|------------------------------------|-------------------------------------|--------|
| (Figure 1a) | | | | |
| $t_{\overline{\text{CS}}}$ | 40 | 50 | 55 | ns min |
| $t_{\overline{\text{L1}}}$ | 40 | 50 | 55 | ns min |
| t_{DS} | 30 | 35 | 40 | ns min |
| t_{DH} | 10 | 10 | 15 | ns min |
| t_{LH} | 90 | 110 | 120 | ns min |
| t_{LW} | 40 | 45 | 45 | ns min |
| (Figure 1b) | | | | |
| t_{LOW} | 130 | 150 | 165 | ns min |
| t_{HIGH} | 40 | 45 | 45 | ns min |
| t_{DS} | 120 | 140 | 150 | ns min |
| t_{DH} | 10 | 10 | 15 | ns min |

Specifications subject to change without notice.

Specifications in **boldface** are tested on all production units at final electrical test. Results from those tests are used to calculate outgoing quality levels. All min and max specifications are guaranteed. Those shown in boldface are tested on all production units.

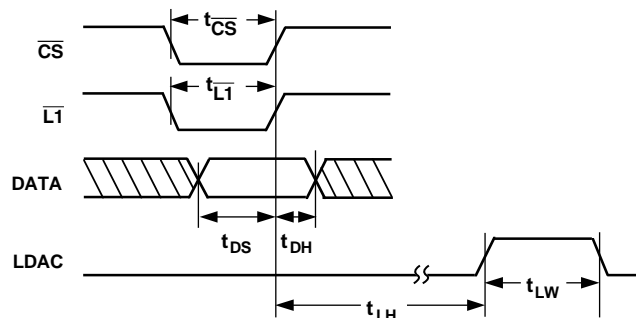
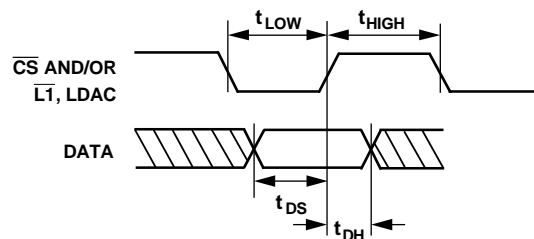

Figure 1a. AD669 Level Triggered Timing Diagram



TIE $\overline{\text{CS}}$ AND/OR $\overline{\text{L1}}$ TO GROUND OR TOGETHER WITH LDAC

Figure 1b. AD669 Edge Triggered Timing Diagram

AD669

ESD SENSITIVITY

The AD669 features input protection circuitry consisting of large transistors and polysilicon series resistors to dissipate both high-energy discharges (Human Body Model) and fast, low-energy pulses (Charged Device Model). Per Method 3015.2 of MIL-STD-883: C, the AD669 has been classified as a Class 2 device.

Proper ESD precautions are strongly recommended to avoid functional damage or performance degradation. Charges as high as 4000 volts readily accumulate on the human body and test equipment and discharge without detection. Unused devices must be stored in conductive foam or shunts, and the foam should be discharged to the destination socket before devices are removed. For further information on ESD precautions, refer to Analog Devices' ESD Prevention Manual.



ABSOLUTE MAXIMUM RATINGS*

| | |
|--|--|
| V_{CC} to AGND | -0.3 V to +17.0 V |
| V_{EE} to AGND | +0.3 V to -17.0 V |
| V_{LL} to DGND | -0.3 V to +7 V |
| AGND to DGND | ± 1 V |
| Digital Inputs (Pins 5 through 23) to DGND | -1.0 V to +7.0 V |
| REF IN to AGND | ± 10.5 V |
| Span/Bipolar Offset to AGND | ± 10.5 V |
| REF OUT, V_{OUT} | Indefinite Short To AGND, DGND, V_{CC} , V_{EE} , and V_{LL} |

Power Dissipation (Any Package)

| | |
|--------------------------------------|-----------------|
| To +60°C | 1000 mW |
| Derates above +60°C | 8.7 mW/°C |
| Storage Temperature | -65°C to +150°C |
| Lead Temperature (Soldering, 10 sec) | +300°C |

*Stresses above those listed under "Absolute Maximum Ratings" may cause permanent damage to the device. This is a stress rating only, and functional operation of the device at these or any other conditions above those indicated in the operational section of this specification is not implied. Exposure to absolute maximum rating conditions for extended periods may affect device reliability.

PIN CONFIGURATION

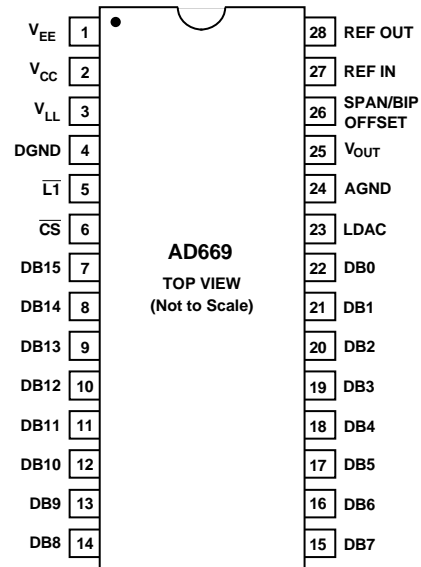

ORDERING GUIDE

| Model | Temperature Range | Linearity Error Max $T_{MIN}-T_{MAX}$ | Gain TC max ppm/°C | Package Description | Package Option* |
|--------------|-------------------|---------------------------------------|--------------------|---------------------|-----------------|
| AD669AN | -40°C to +85°C | ± 4 LSB | 25 | Plastic DIP | N-28 |
| AD669AR | -40°C to +85°C | ± 4 LSB | 25 | SOIC | R-28 |
| AD669BN | -40°C to +85°C | ± 2 LSB | 15 | Plastic DIP | N-28 |
| AD669BR | -40°C to +85°C | ± 2 LSB | 15 | SOIC | R-28 |
| AD669AQ | -40°C to +85°C | ± 4 LSB | 15 | Cerdip | Q-28 |
| AD669BQ | -40°C to +85°C | ± 2 LSB | 15 | Cerdip | Q-28 |
| AD669SQ | -55°C to +125°C | ± 4 LSB | 15 | Cerdip | Q-28 |
| AD669/883B** | -55°C to +125°C | ** | ** | ** | ** |

*N = Plastic DIP; Q = Cerdip; R = SOIC.
** Refer to AD669/883B military data sheet.

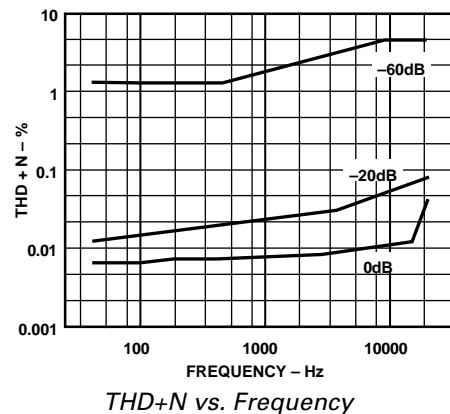
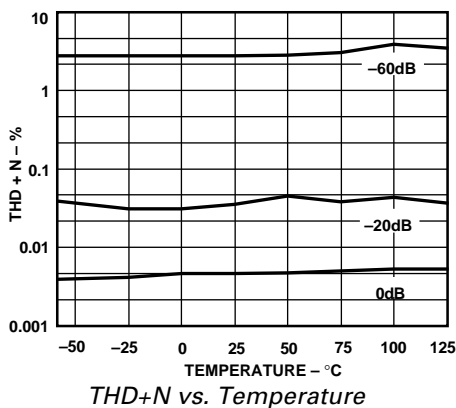

DEFINITIONS OF SPECIFICATIONS

INTEGRAL NONLINEARITY: Analog Devices defines integral nonlinearity as the maximum deviation of the actual, adjusted DAC output from the ideal analog output (a straight line drawn from 0 to FS-1 LSB) for any bit combination. This is also referred to as relative accuracy.

DIFFERENTIAL NONLINEARITY: Differential nonlinearity is the measure of the change in the analog output, normalized to full scale, associated with a 1 LSB change in the digital input code. Monotonic behavior requires that the differential linearity error be within ± 1 LSB over the temperature range of interest.

MONOTONICITY: A DAC is monotonic if the output either increases or remains constant for increasing digital inputs with the result that the output will always be a single-valued function of the input.

GAIN ERROR: Gain error is a measure of the output error between an ideal DAC and the actual device output with all 1s loaded after offset error has been adjusted out.

OFFSET ERROR: Offset error is a combination of the offset errors of the voltage-mode DAC and the output amplifier and is measured with all 0s loaded in the DAC.

BIPOLAR ZERO ERROR: When the AD669 is connected for bipolar output and 10 . . . 000 is loaded in the DAC, the deviation of the analog output from the ideal midscale value of 0 V is called the bipolar zero error.

DRIFT: Drift is the change in a parameter (such as gain, offset and bipolar zero) over a specified temperature range. The drift temperature coefficient, specified in ppm/ $^{\circ}$ C, is calculated by measuring the parameter at T_{MIN} , 25 $^{\circ}$ C and T_{MAX} and dividing the change in the parameter by the corresponding temperature change.

TOTAL HARMONIC DISTORTION + NOISE: Total harmonic distortion + noise (THD+N) is defined as the ratio of the square root of the sum of the squares of the values of the harmonics and noise to the value of the fundamental input frequency. It is usually expressed in percent (%).

THD+N is a measure of the magnitude and distribution of linearity error, differential linearity error, quantization error and noise. The distribution of these errors may be different, depending upon the amplitude of the output signal. Therefore, to be the most useful, THD+N should be specified for both large and small signal amplitudes.

SIGNAL-TO-NOISE RATIO: The signal-to-noise ratio is defined as the ratio of the amplitude of the output when a full-scale signal is present to the output with no signal present. This is measured in dB.

DIGITAL-TO-ANALOG GLITCH IMPULSE: This is the amount of charge injected from the digital inputs to the analog output when the inputs change state. This is measured at half scale when the DAC switches around the MSB and as many as possible switches change state, i.e., from 011 . . . 111 to 100 . . . 000.

DIGITAL FEEDTHROUGH: When the DAC is not selected (i.e., \overline{CS} is held high), high frequency logic activity on the digital inputs is capacitively coupled through the device to show up as noise on the V_{OUT} pin. This noise is digital feedthrough.

THEORY OF OPERATION

The AD669 uses an array of bipolar current sources with MOS current steering switches to develop a current proportional to the applied digital word, ranging from 0 mA to 2 mA. A segmented architecture is used, where the most significant four data bits are thermometer decoded to drive 15 equal current sources. The lesser bits are scaled using a R-2R ladder, then applied together with the segmented sources to the summing node of the output amplifier. The internal span/bipolar offset resistor can be connected to the DAC output to provide a 0 V to +10 V span, or it can be connected to the reference input to provide a -10 V to +10 V span.

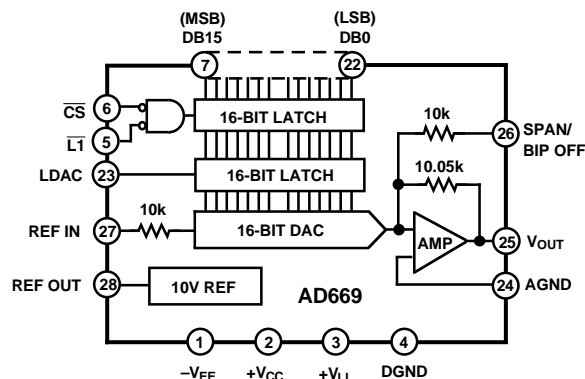

Figure 2. AD669 Functional Block Diagram

ANALOG CIRCUIT CONNECTIONS

Internal scaling resistors provided in the AD669 may be connected to produce a unipolar output range of 0 V to +10 V or a bipolar output range of -10 V to +10 V. Gain and offset drift are minimized in the AD669 because of the thermal tracking of the scaling resistors with other device components.

UNIPOLAR CONFIGURATION

The configuration shown in Figure 3a will provide a unipolar 0 V to +10 V output range. In this mode, 50 Ω resistors are tied between the span/bipolar offset terminal (Pin 26) and V_{OUT} (Pin 25), and between REF OUT (Pin 28) and REF IN (Pin 27). It is possible to use the AD669 without any external components by tying Pin 28 directly to Pin 27 and Pin 26 directly to Pin 25. Eliminating these resistors will increase the gain error by 0.25% of FSR.

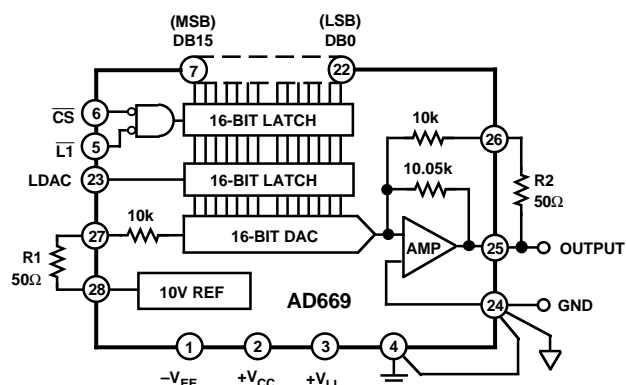

Figure 3a. 0 V to +10 V Unipolar Voltage Output

AD669

If it is desired to adjust the gain and offset errors to zero, this can be accomplished using the circuit shown in Figure 3b. The adjustment procedure is as follows:

STEP 1 . . . ZERO ADJUST

Turn all bits OFF and adjust zero trimmer, R4, until the output reads 0.000000 volts (1 LSB = 153 μ V).

STEP 2 . . . GAIN ADJUST

Turn all bits ON and adjust gain trimmer, R1, until the output is 9.999847 volts. (Full scale is adjusted to 1 LSB less than the nominal full scale of 10.000000 volts).

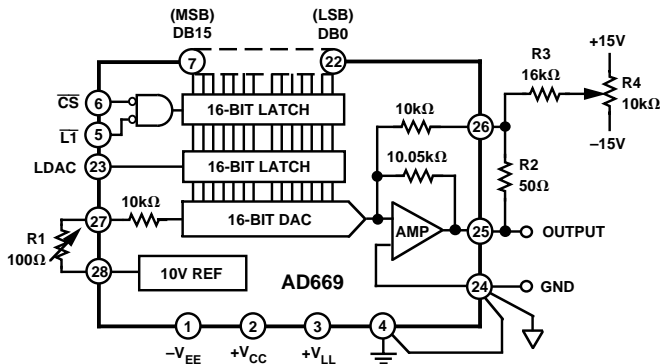

Figure 3b. 0 V to +10 V Unipolar Voltage Output with Gain and Offset Adjustment

BIPOLAR CONFIGURATION

The circuit shown in Figure 4a will provide a bipolar output voltage from -10.000000 V to +9.999694 V with positive full scale occurring with all bits ON. As in the unipolar mode, resistors R1 and R2 may be eliminated altogether to provide AD669 bipolar operation without any external components. Eliminating these resistors will increase the gain error by 0.50% of FSR in the bipolar mode.

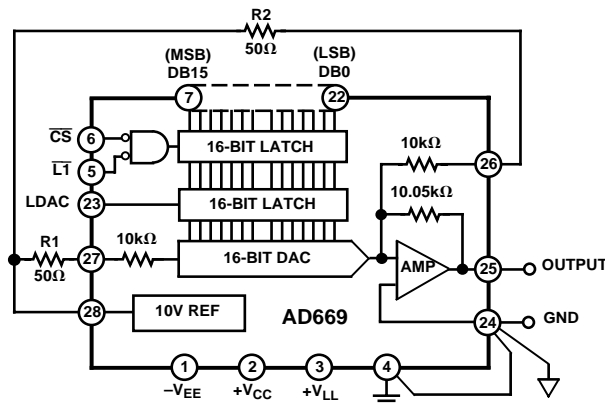

Figure 4a. ± 10 V Bipolar Voltage Output

Gain offset and bipolar zero errors can be adjusted to zero using the circuit shown in Figure 4b as follows:

STEP I . . . OFFSET ADJUST

Turn OFF all bits. Adjust trimmer R2 to give -10.000000 volts output.

STEP II . . . GAIN ADJUST

Turn all bits ON and adjust R1 to give a reading of +9.999694 volts.

STEP III . . . BIPOLAR ZERO ADJUST

(Optional) In applications where an accurate zero output is required, set the MSB ON, all other bits OFF, and readjust R2 for zero volts output.

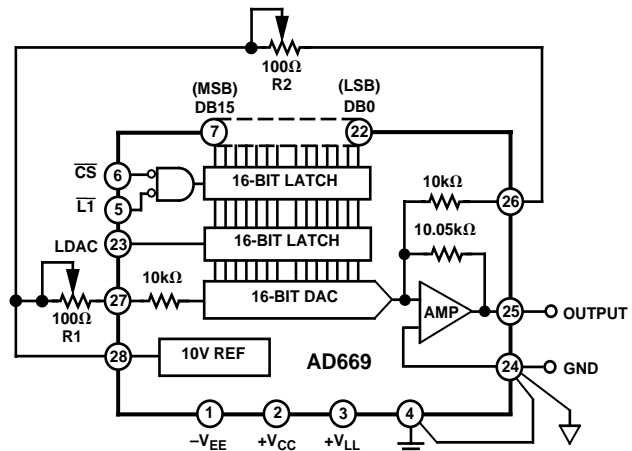

Figure 4b. ± 10 V Bipolar Voltage Output with Gain and Offset Adjustment

It should be noted that using external resistors will introduce a small temperature drift component beyond that inherent in the AD669. The internal resistors are trimmed to ratio-match and temperature-track other resistors on chip, even though their absolute tolerances are $\pm 20\%$ and absolute temperature coefficients are approximately -50 ppm/ $^{\circ}$ C. In the case that external resistors are used, the temperature coefficient mismatch between internal and external resistors, multiplied by the sensitivity of the circuit to variations in the external resistor value, will be the resultant additional temperature drift.

INTERNAL/EXTERNAL REFERENCE USE

The AD669 has an internal low noise buried Zener diode reference which is trimmed for absolute accuracy and temperature coefficient. This reference is buffered and optimized for use in a high speed DAC and will give long-term stability equal or superior to the best discrete Zener diode references. The performance of the AD669 is specified with the internal reference driving the DAC since all trimming and testing (especially for gain and bipolar offset) is done in this configuration.

The internal reference has sufficient buffering to drive external circuitry in addition to the reference currents required for the DAC (typically 1 mA to REF IN and 1 mA to BIPOLAR OFFSET). A minimum of 2 mA is available for driving external loads. The AD669 reference output should be buffered with an external op amp if it is required to supply more than 4 mA total current. The reference is tested and guaranteed to $\pm 0.2\%$ max error. The temperature coefficient is comparable to that of the gain TC for a particular grade.

If an external reference is used (10.000 V, for example), additional trim range should be provided, since the internal reference has a tolerance of ± 20 mV, and the AD669 gain and bipolar offset are both trimmed with the internal reference. The optional gain and offset trim resistors in Figures 5 and 6 provide enough adjustment range to null these errors.

It is also possible to use external references other than 10 volts with slightly degraded linearity specifications. The recommended range of reference voltages is +5 V to +10.24 V, which

allows 5 V, 8.192 V and 10.24 V ranges to be used. For example, by using the AD586 5 V reference, outputs of 0 V to +5 V unipolar or ± 5 V bipolar can be realized. Using the AD586 voltage reference makes it possible to operate the AD669 off of ± 12 V supplies with 10% tolerances.

Figure 5 shows the AD669 using the AD586 5 V reference in the bipolar configuration. This circuit includes two optional potentiometers and one optional resistor that can be used to adjust the gain, offset and bipolar zero errors in a manner similar to that described in the BIPOLAR CONFIGURATION section. Use -5.000000 V and $+4.999847$ as the output values.

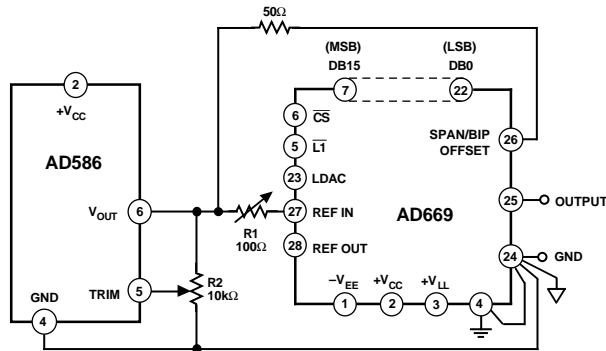

Figure 5. Using the AD669 with the AD586 5 V Reference

USING THE AD669 WITH THE AD688 HIGH PRECISION VOLTAGE REFERENCE

The AD669 is specified for gain drift from 15 ppm/°C to 25 ppm/°C (depending upon grade) using its internal 10 volt reference. Since the internal reference contributes the vast majority of this drift, an external high precision voltage reference will greatly improve performance over temperature. As shown in Figure 6, the +10 volt output from the AD688 is used as the AD669 reference. With a 3 ppm/°C drift over the industrial temperature range, the AD688 will improve the gain drift by a factor of 5 to a factor of 8 (depending upon the grade of the AD669 being used). Using this combination may result in apparent increases in initial gain error due to the differences between the internal reference by which the device is laser trimmed and the external reference with which the device is actually applied. The AD669 internal reference is specified to be 10 volts ± 20 mV whereas the AD688 is specified as 10 volts ± 5 mV. This may result in an additional 5 mV (33 LSBs) of apparent initial gain error beyond the specified AD669 gain error. The circuit shown in Figure 6 also makes use of the -10 V AD688 output to allow the unipolar offset and gain to be adjusted to zero in the manner described in the UNIPOLAR CONFIGURATION section.

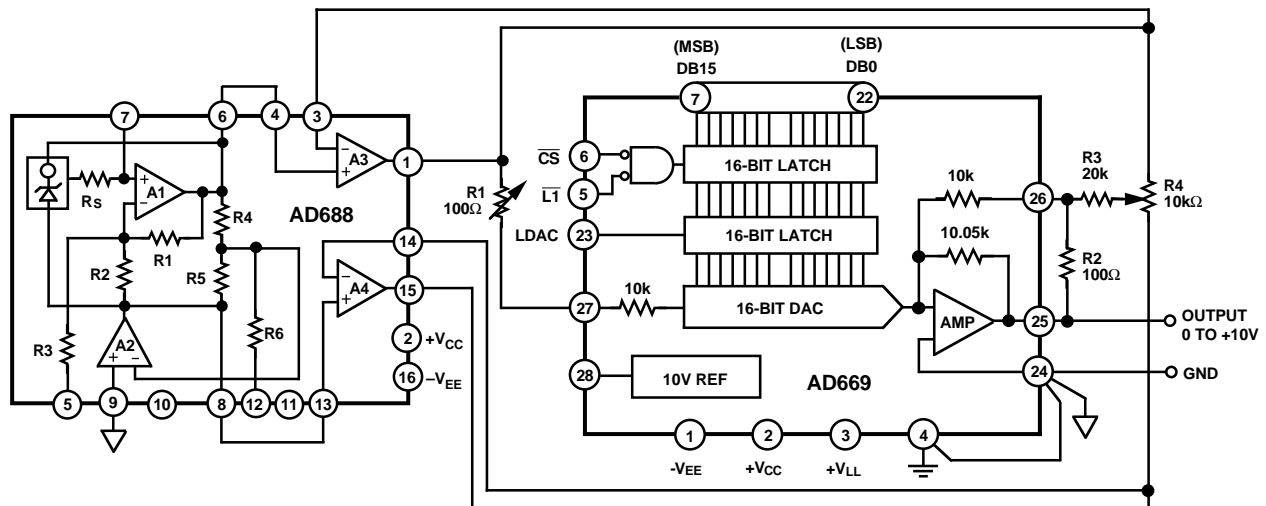

Figure 6. Using the AD669 with the AD688 High Precision ± 10 V Reference

AD669

OUTPUT SETTLING AND GLITCH

The AD669's output buffer amplifier typically settles to within 0.0008% FS (1/2 LSB) of its final value in 8 μ s for a full-scale step. Figures 7a and 7b show settling for a full-scale and an LSB step, respectively, with a 2 k Ω , 1000 pF load applied. The guaranteed maximum settling time at +25°C for a full-scale step is 13 μ s with this load. The typical settling time for a 1 LSB step is 2.5 μ s.

The digital-to-analog glitch impulse is specified as 15 nV-s typical. Figure 7c shows the typical glitch impulse characteristic at the code 011 . . . 111 to 100 . . . 000 transition when loading the second rank register from the first rank register.

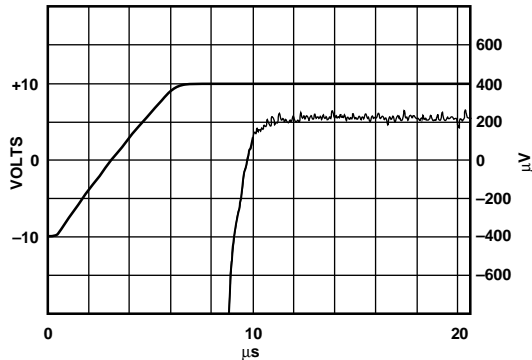

a. -10 V to +10 V Full-Scale Step Settling

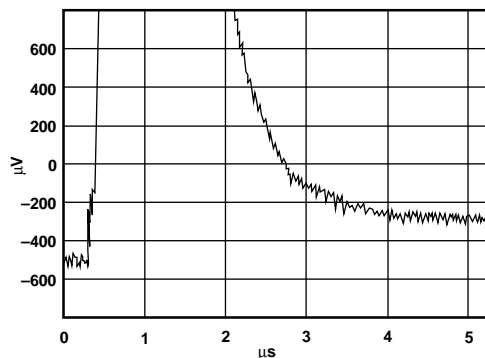

b. LSB Step Settling

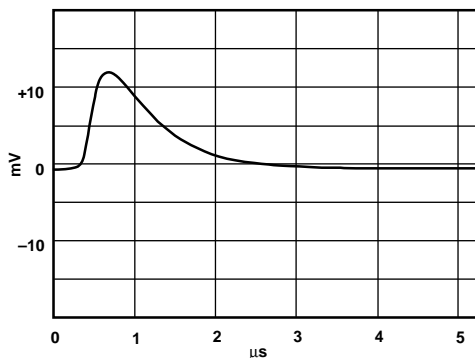

c. D-to-A Glitch Impulse
Figure 7. Output Characteristics

DIGITAL CIRCUIT DETAILS

The bus interface logic of the AD669 consists of two independently addressable registers in two ranks. The first rank consists of a 16-bit register which is loaded directly from a 16-bit micro-processor bus. Once the 16-bit data word has been loaded in the first rank, it can be loaded into the 16-bit register of the second rank. This double-buffered organization avoids the generation of spurious analog output values.

The first rank latch is controlled by $\overline{\text{CS}}$ and $\overline{\text{L1}}$. Both of these inputs are active low and are level-triggered. This means that data present during the time when both $\overline{\text{CS}}$ and $\overline{\text{L1}}$ are low will enter the latch. When either one of these signals returns high, the data is latched.

The second rank latch is controlled by LDAC. This input is active high and is also level-triggered. Data that is present when LDAC is high will enter the latch, and hence the DAC will change state. When this pin returns low, the data is latched in the DAC.

Note that LDAC is not gated with $\overline{\text{CS}}$ or any other control signal. This makes it possible to simultaneously update all of the AD669's present in a multi-DAC system by tying the LDAC pins together. After the first rank register of each DAC has been individually loaded and latched, the second rank registers are then brought high together, updating all of the DACs at the same time. To reduce bit skew, it is suggested to leave 100 ns between the first rank load and the second rank load.

The first rank latch and second rank latch can be used together in a master-slave or edge-triggered configuration. This mode of operation occurs when LDAC and $\overline{\text{CS}}$ are tied together with $\overline{\text{L1}}$ tied to ground. Rising edges on the LDAC- $\overline{\text{CS}}$ pair will update the DAC with the data presented preceding the edge. The timing diagram for operation in this mode can be seen in Figure 1b. Note, however, that the sum of t_{LOW} and t_{HIGH} must be long enough to allow the DAC output to settle to its new value.

Table I. AD669 Truth Table

| $\overline{\text{CS}}$ | $\overline{\text{L1}}$ | LDAC | Operation |
|------------------------|------------------------|------|-------------------------|
| 0 | 0 | X | First Rank Enable |
| X | 1 | X | First Rank Latched |
| 1 | X | X | First Rank Latched |
| X | X | 1 | Second Rank Enabled |
| X | X | 0 | Second Rank Latched |
| 0 | 0 | 1 | All Latches Transparent |

"X" = Don't Care

It is possible to make the second rank register transparent by tying Pin 23 high. Any data appearing in the first rank register will then appear at the output of the DAC. It should be noted, however, that the deskewing provided by the second rank latch is then defeated, and glitch impulse may increase. If it is desired to make both registers transparent, this can be done by tying Pins 5 and 6 low and Pin 23 high. Table I shows the truth table for the AD669, while the timing diagram is found in Figure 1.

INPUT CODING

The AD669 uses positive-true binary input coding. Logic "1" is represented by an input voltage greater than 2.0 V, and Logic "0" is defined as an input voltage less than 0.8 V.

Unipolar coding is straight binary, where all zeros (0000H) on the data inputs yields a zero analog output and all ones (FFFFH) yields an analog output 1 LSB below full scale.

Bipolar coding is offset binary, where an input code of 0000H yields a minus full-scale output, an input of FFFFH yields an output 1 LSB below positive full scale, and zero occurs for an input code with only the MSB on (8000H).

The AD669 can be used with twos complement input coding if an inverter is used on the MSB (DB15).

DIGITAL INPUT CONSIDERATIONS

The threshold of the digital input circuitry is set at 1.4 volts. The input lines can thus interface with any type of 5 volt logic.

The AD669 data and control inputs will float to indeterminate logic states if left open. It is important that \overline{CS} and \overline{LI} be connected to DGND and \overline{CS} and \overline{LI} be connected to DGND and \overline{CS} be tied to V_{LL} if these pins are not used.

Fanout for the AD669 is 40 when used with a standard low power Schottky gate output device.

16-BIT MICROPROCESSOR INTERFACE

The 16-bit parallel registers of the AD669 allow direct interfacing to 16-bit general purpose and DSP microprocessor buses. The following examples illustrate typical AD669 interface configurations.

AD669 TO ADSP-2101 INTERFACE

The flexible interface of the AD669 minimizes the required “glue” logic when it is connected in configurations such as the one shown in Figure 8. The AD669 is mapped into the ADSP-2101’s memory space and requires two wait states using a 12.5 MHz processor clock.

In this configuration, the ADSP-2101 is set up to use the internal timer to interrupt the processor at the desired sample rate. The \overline{WR} pin and data lines D8–D23 from the ADSP-2101 are tied directly to the \overline{LI} and DB0 through DB15 pins of the AD669, respectively. The decoded signal \overline{CS} is connected to both \overline{CS} and LDAC. When a timer interrupt is detected, the ADSP-2101 automatically vectors to the appropriate service routine with minimal overhead. The interrupt routine then instructs the processor to execute a data memory write to the address of the AD669.

The \overline{WR} pin and \overline{CS} both go low causing the first 16-bit latch inside the AD669 to be transparent. The data present in the first rank is then latched by the rising edge of \overline{WR} . The rising edge of \overline{CS} will cause the second rank 16-bit latch to become transparent updating the output of the DAC. The length of \overline{WR} is extended by two wait states to comply with the timing requirements of t_{LOW} shown in Figure 1b. It is important to latch the data with the rising edge of \overline{WR} rather than the decoded \overline{CS} . This is necessary to comply with the t_{DH} specification of the AD669.

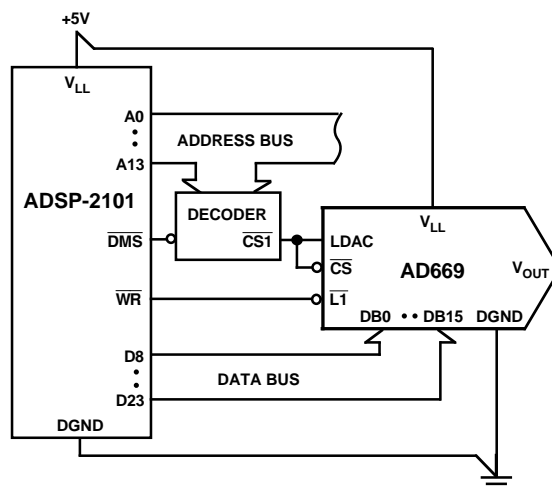

a. ADSP-2101 to AD669 Interface

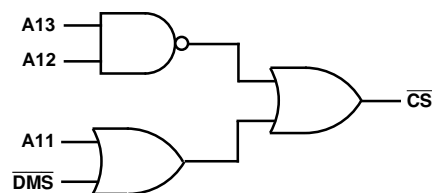

b. Typical Address Decoder

Figure 8. ADSP-2101 to AD669 Interface

Figure 8b shows the circuitry a typical decoder might include. In this case, a data memory write to any address in the range 3000H to 3400H will result in the AD669 being updated. These decoders will vary greatly depending on the number of devices memory-mapped by the processor.

AD669 TO DSP56001 INTERFACE

Figure 9 shows the interface between the AD669 and the DSP56001. Like the ADSP-2101, the AD669 is mapped into the DSP56001’s memory space. This application was tested with a processor clock of 20.48 MHz ($t_{CYC} = 97.66$ ns) although faster rates are possible.

An external clock connected to the \overline{IRQA} pin of the DSP56001 interrupts the processor at the desired sample rate. If ac performance is important, this clock should be synchronous with the DSP56001 processor clock. Asynchronous clocks will cause jitter on the latch signal due to the uncertainty associated with the acknowledgment of the interrupt. A synchronous clock is easily generated by dividing down the clock from the DSP crystal. If ac performance is not important, it is not necessary for \overline{IRQA} to be synchronous.

After the interrupt is acknowledged, the interrupt routine initiates a memory write cycle. All of the AD669 control inputs are

AD669

tied together which configures the input stage as an edge triggered 16-bit register. The rising edge of the decoded signal latches the data and updates the output of the DAC. It is necessary to insert wait states after the processor initiates the write cycle to comply with the timing requirements t_{LOW} shown in Figure 1b. The number of wait states that are required will vary depending on the processor cycle time. The equation given in Figure 9 can be used to determine the number of wait states given the frequency of the processor crystal.

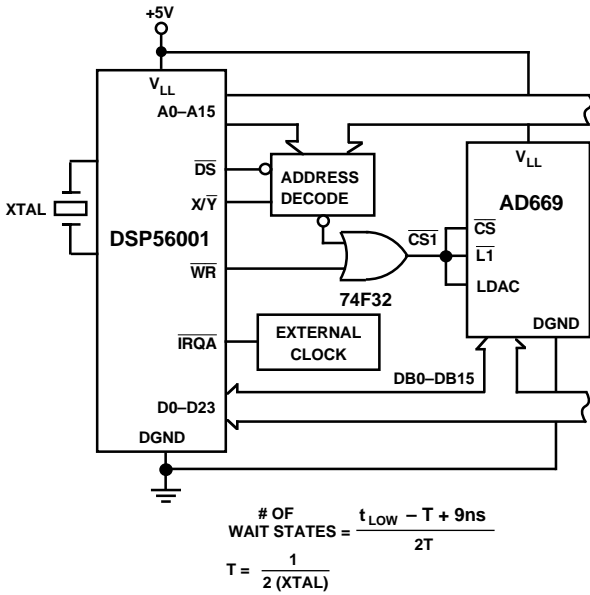

Figure 9. DSP56001 to AD669 Interface

As an example, the 20.48 MHz crystal used in this application results in $T = 24.4$ ns which means that the required number of wait states is about 2.76. This must be rounded to the next highest integer to assure that the minimum pulse widths comply with those required by the AD669. As the speed of the processor is increased, the data hold time relative to $CS1$ decreases. As processor clocks increase beyond 20.48 MHz, a configuration such as the one shown for the ADSP-2101 is the better choice.

AD669 TO 8086 INTERFACE

Figure 10 shows the 8086 16-bit microprocessor connected to multiple AD669s. The double-buffered capability of the AD669 allows the microprocessor to write to each AD669 individually and then update all the outputs simultaneously. Processor speeds of 6, 8, and 10 MHz require no wait states to interface with the AD669.

The 8086 software routine begins by writing a data word to the $CS1$ address. The decoder must latch the address using the ALE signal. The decoded $CS1$ pulse goes low causing the first rank latch of the associated AD669 to become transparent.

Simultaneously, the 8086 places data on the multiplexed bus which is then latched into the first rank of the AD669 with the rising edge of the WR pulse. Care should be taken to prevent excessive delays through the decoder potentially resulting in a violation of the AD669 data hold time (t_{DH}).

The same procedure is repeated until all three AD669s have had their first rank latches loaded with the desired data. A final write command to the LDAC address results in a high-going pulse that causes the second rank latches of all the AD669s to become transparent. The falling edge of LDAC latches the data from the first rank until the next update. This scheme is easily expanded to include as many AD669s as required.

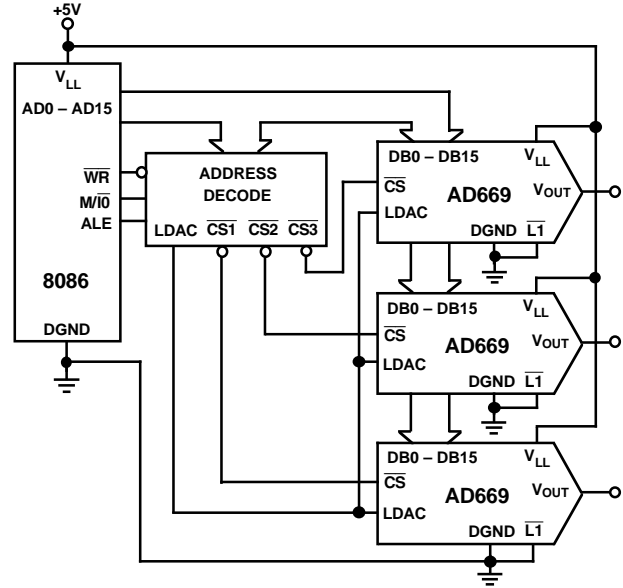

Figure 10. 8086-to-AD669 Interface

8-BIT MICROPROCESSOR INTERFACE

The AD669 can easily be operated with an 8-bit bus by the addition of an octal latch. The 16-bit first rank register is loaded from the 8-bit bus as two bytes. Figure 11 shows the configuration when using a 74HC573 octal latch.

The eight most significant bits are latched into the 74HC573 by setting the "latch enable" control line low. The eight least significant bits are then placed onto the bus. Now all sixteen bits can be simultaneously loaded into the first rank register of the AD669 by setting CS and $L1$ low.

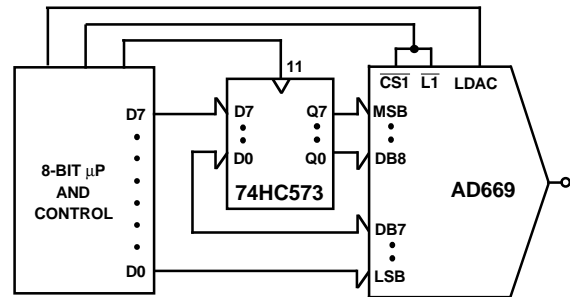

Figure 11. Connections for 8-Bit Bus Interface

NOISE

In high resolution systems, noise is often the limiting factor. A 16-bit DAC with a 10 volt span has an LSB size of $153\ \mu\text{V}$ ($-96\ \text{dB}$). Therefore, the noise floor must remain below this level in the frequency range of interest. The AD669's noise spectral density is shown in Figures 12 and 13. Figure 12 shows the DAC output noise voltage spectral density for a 20 V span excluding the reference. This figure shows the $1/f$ corner frequency at 100 Hz and the wideband noise to be below $120\ \text{nV}/\sqrt{\text{Hz}}$. Figure 13 shows the reference noise voltage spectral density. This figure shows the reference wideband noise to be below $125\ \text{nV}/\sqrt{\text{Hz}}$.

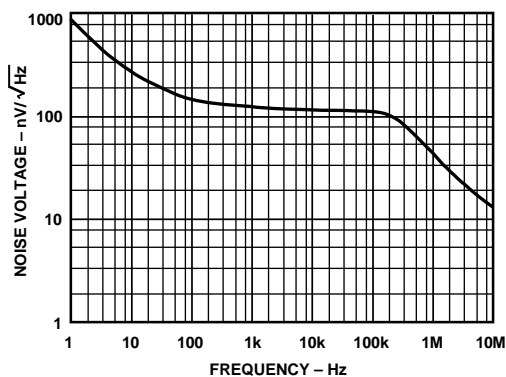

Figure 12. DAC Output Noise Voltage Spectral Density

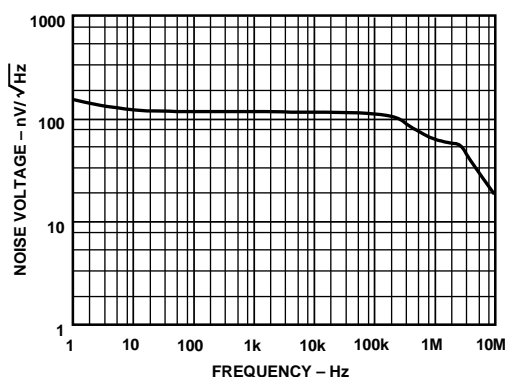

Figure 13. Reference Noise Voltage Spectral Density

BOARD LAYOUT

Designing with high resolution data converters requires careful attention to board layout. Trace impedance is the first issue. A $306\ \mu\text{A}$ current through a $0.5\ \Omega$ trace will develop a voltage drop of $153\ \mu\text{V}$, which is 1 LSB at the 16-bit level for a 10 V full-scale span. In addition to ground drops, inductive and capacitive coupling need to be considered, especially when high accuracy analog signals share the same board with digital signals. Finally, power supplies need to be decoupled in order to filter out ac noise.

Analog and digital signals should not share a common path. Each signal should have an appropriate analog or digital return routed close to it. Using this approach, signal loops enclose a small area, minimizing the inductive coupling of noise. Wide PC tracks, large gauge wire, and ground planes are highly recommended to provide low impedance signal paths. Separate analog and digital ground planes should also be utilized, with a single interconnection point to minimize ground loops. Analog signals should be routed as far as possible from digital signals and should cross them at right angles.

One feature that the AD669 incorporates to help the user layout is the analog pins (V_{CC} , V_{EE} , REF OUT, REF IN, SPAN/BIP OFFSET, V_{OUT} and AGND) are adjacent to help isolate analog signals from digital signals.

SUPPLY DECOUPLING

The AD669 power supplies should be well filtered, well regulated, and free from high frequency noise. Switching power supplies are not recommended due to their tendency to generate spikes which can induce noise in the analog system.

Decoupling capacitors should be used in very close layout proximity between all power supply pins and ground. A $10\ \mu\text{F}$ tantalum capacitor in parallel with a $0.1\ \mu\text{F}$ ceramic capacitor provides adequate decoupling. V_{CC} and V_{EE} should be bypassed to analog ground, while V_{LL} should be decoupled to digital ground.

An effort should be made to minimize the trace length between the capacitor leads and the respective converter power supply and common pins. The circuit layout should attempt to locate the AD669, associated analog circuitry and interconnections as far as possible from logic circuitry. A solid analog ground plane around the AD669 will isolate large switching ground currents. For these reasons, the use of wire wrap circuit construction is not recommended; careful printed circuit construction is preferred.

GROUNDING

The AD669 has two pins, designated analog ground (AGND) and digital ground (DGND.) The analog ground pin is the "high quality" ground reference point for the device. Any external loads on the output of the AD669 should be returned to analog ground. If an external reference is used, this should also be returned to the analog ground.

If a single AD669 is used with separate analog and digital ground planes, connect the analog ground plane to AGND and the digital ground plane to DGND keeping lead lengths as short as possible. Then connect AGND and DGND together at the AD669. If multiple AD669s are used or the AD669 shares analog supplies with other components, connect the analog and digital returns together once at the power supplies rather than at each chip. This single interconnection of grounds prevents large ground loops and consequently prevents digital currents from flowing through the analog ground.

OUTLINE DIMENSIONS

Dimensions shown in inches and (mm).

N-28

28-Lead Plastic DIP

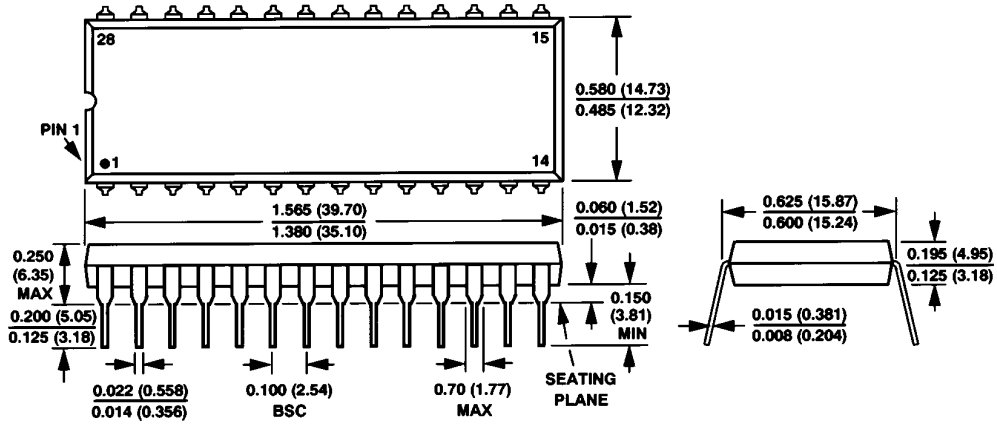

Q-28
28-Lead Cerdip

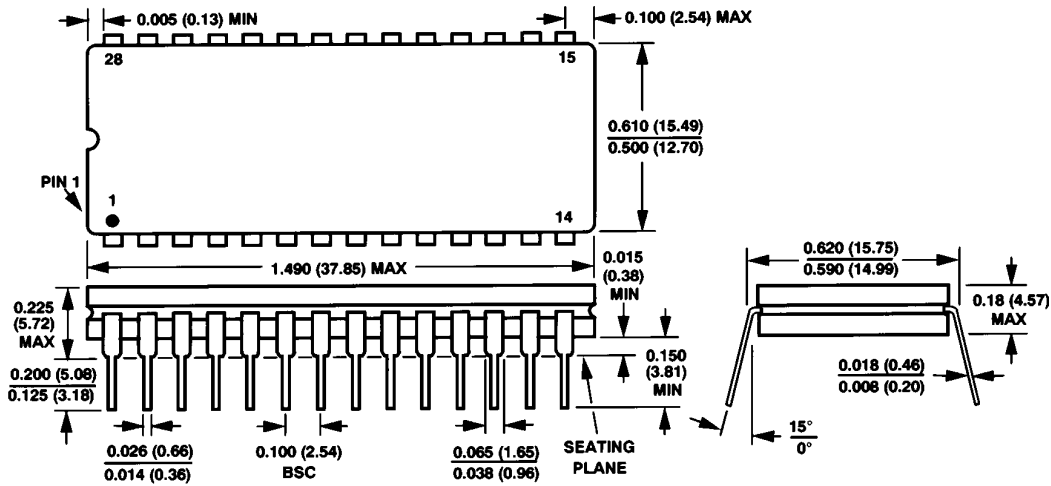

R-28
28-Lead Small Outline (SOIC)

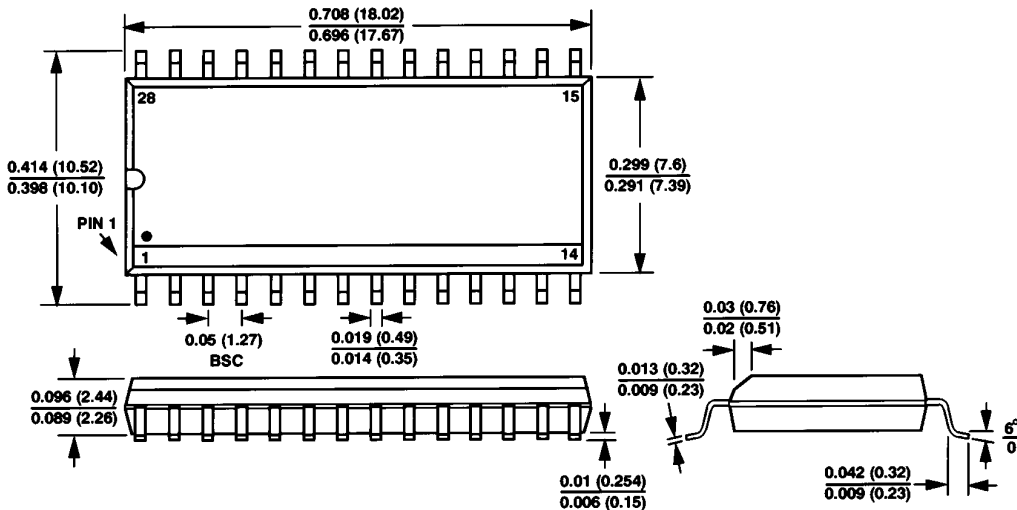



Компания «ЭлектроПласт» предлагает заключение долгосрочных отношений при поставках импортных электронных компонентов на взаимовыгодных условиях!

Наши преимущества:

- Оперативные поставки широкого спектра электронных компонентов отечественного и импортного производства напрямую от производителей и с крупнейших мировых складов;
- Поставка более 17-ти миллионов наименований электронных компонентов;
- Поставка сложных, дефицитных, либо снятых с производства позиций;
- Оперативные сроки поставки под заказ (от 5 рабочих дней);
- Экспресс доставка в любую точку России;
- Техническая поддержка проекта, помощь в подборе аналогов, поставка прототипов;
- Система менеджмента качества сертифицирована по Международному стандарту ISO 9001;
- Лицензия ФСБ на осуществление работ с использованием сведений, составляющих государственную тайну;
- Поставка специализированных компонентов (Xilinx, Altera, Analog Devices, Intersil, Interpoint, Microsemi, Aeroflex, Peregrine, Syfer, Eurofarad, Texas Instrument, Miteq, Cobham, E2V, MA-COM, Hittite, Mini-Circuits, General Dynamics и др.);

Помимо этого, одним из направлений компании «ЭлектроПласт» является направление «Источники питания». Мы предлагаем Вам помощь Конструкторского отдела:

- Подбор оптимального решения, техническое обоснование при выборе компонента;
- Подбор аналогов;
- Консультации по применению компонента;
- Поставка образцов и прототипов;
- Техническая поддержка проекта;
- Защита от снятия компонента с производства.



Как с нами связаться

Телефон: 8 (812) 309 58 32 (многоканальный)

Факс: 8 (812) 320-02-42

Электронная почта: org@eplast1.ru

Адрес: 198099, г. Санкт-Петербург, ул. Калинина, дом 2, корпус 4, литера А.