

Digilent PmodSSD™ Peripheral Module Board Reference Manual

Revision: March 6, 2007



www.digilentinc.com

215 E Main Suite D | Pullman, WA 99163
(509) 334 6306 Voice and Fax

Overview

The PmodSSD offers a single two-digit seven-segment display device (7sd) that can attach directly to any Digilent system board. The 7sd uses high-bright LEDs that can be easily readable with less than 5mA of current, so they can be driven directly from most system boards.

Features include:

- two high bright seven-segment displays
- a 6-pin system connector
- small form factor (0.80" x 0.80").

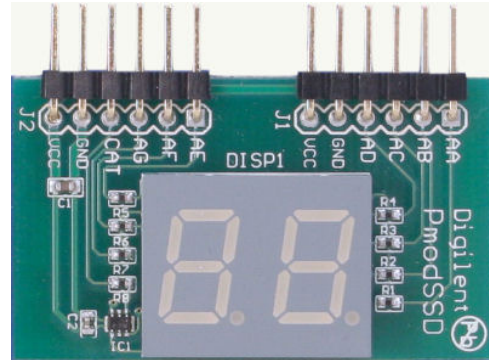

Functional Description

The two digits on the common cathode seven-segment LED display are each composed of seven segments arranged in a “figure 8” pattern, with an LED embedded in each segment. Segment LEDs can be individually illuminated, so any one of 128 patterns can be displayed on a digit by illuminating certain LED segments and leaving the others dark. Of these 128 possible patterns, the ten corresponding to the decimal digits are the most useful.

The cathodes of the seven LEDs forming each digit are tied together into one “common cathode” circuit node, but the LED anodes remain separate. The common cathode signals are available as two “digit enable” input signals to the display. The anodes of similar segments on both digits are connected into seven circuit nodes that are available from the Pmod connector pins (so, for example, the two “D” anode signals from the two digits are connected to the P4 pin on J1). These seven anode signals are available as inputs to the 2-digit display. This signal connection scheme

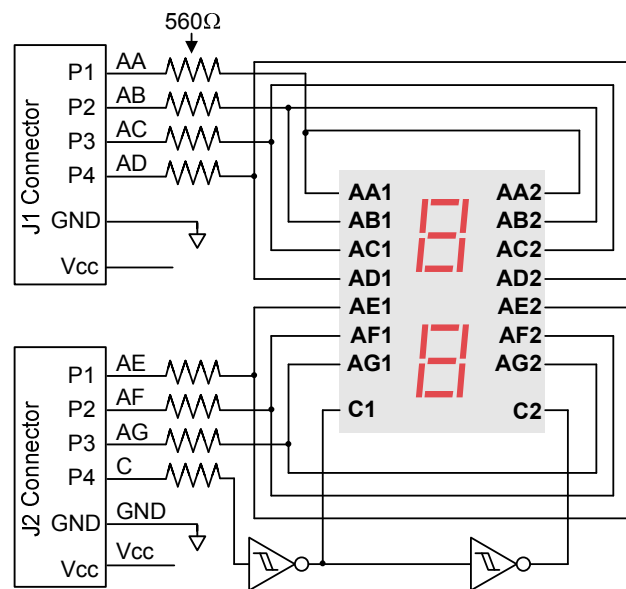

Seven-Segment Display Connection Diagram

creates a multiplexed display, where the anode signals are common to both digits but they can only illuminate the segments of the digit whose corresponding cathode signal is asserted.

A scanning display controller circuit can be used to show a two-digit number on the display. This circuit drives the anode signals and corresponding cathode patterns of each

digit in a repeating, continuous succession, at an update rate that is faster than the human eye can respond. Each digit is illuminated one-half of the time, but because the eye cannot perceive the darkening of a digit before it is illuminated again, the digit appears continuously illuminated. If the update or “refresh” rate is slowed to a given point (around 45 hertz), then most people will begin to see the display flicker.

In order for each of the four digits to appear bright and continuously illuminated, both digits should be driven once every 1 to 16ms (for a refresh frequency of 1KHz to 60Hz). For example, in a 60Hz refresh scheme, the entire display would be refreshed once every 16ms, and each digit would be illuminated for 1/2 of the refresh cycle, or 8ms. The controller must assure that the correct anode pattern is present when the corresponding cathode signal is driven. To illustrate the process, if Cat1 is asserted while AB and AC are asserted, then a “1” will be displayed in digit position 1. Then, if Cat2 is asserted while AA, AB and AC are asserted, then a “7” will be displayed in digit position 2. If Cat1 and AB, AC are driven for 8ms, and then Cat2 and AA, AB, AC are driven for 8ms in an endless succession, the display will show “17”. An example timing diagram for a two-digit controller is shown below.

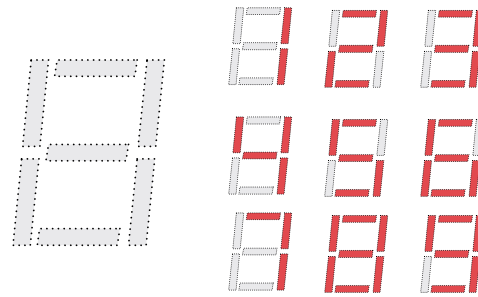

An un-illuminated seven-segment display, and nine illumination patterns corresponding to decimal digits

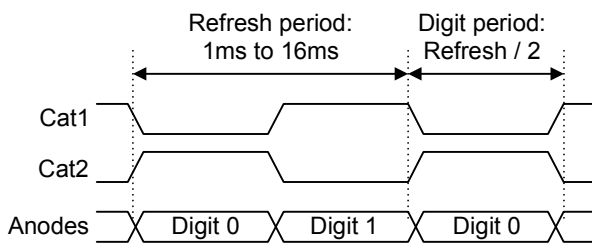
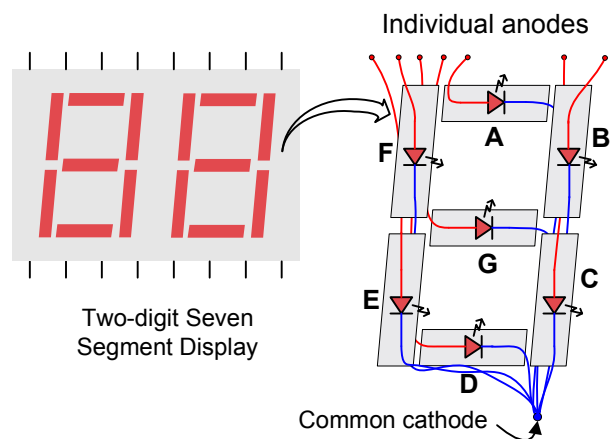



Компания «ЭлектроПласт» предлагает заключение долгосрочных отношений при поставках импортных электронных компонентов на взаимовыгодных условиях!

Наши преимущества:

- Оперативные поставки широкого спектра электронных компонентов отечественного и импортного производства напрямую от производителей и с крупнейших мировых складов;
- Поставка более 17-ти миллионов наименований электронных компонентов;
- Поставка сложных, дефицитных, либо снятых с производства позиций;
- Оперативные сроки поставки под заказ (от 5 рабочих дней);
- Экспресс доставка в любую точку России;
- Техническая поддержка проекта, помощь в подборе аналогов, поставка прототипов;
- Система менеджмента качества сертифицирована по Международному стандарту ISO 9001;
- Лицензия ФСБ на осуществление работ с использованием сведений, составляющих государственную тайну;
- Поставка специализированных компонентов (Xilinx, Altera, Analog Devices, Intersil, Interpoint, Microsemi, Aeroflex, Peregrine, Syfer, Eurofarad, Texas Instrument, Miteq, Cobham, E2V, MA-COM, Hittite, Mini-Circuits, General Dynamics и др.);

Помимо этого, одним из направлений компании «ЭлектроПласт» является направление «Источники питания». Мы предлагаем Вам помощь Конструкторского отдела:

- Подбор оптимального решения, техническое обоснование при выборе компонента;
- Подбор аналогов;
- Консультации по применению компонента;
- Поставка образцов и прототипов;
- Техническая поддержка проекта;
- Защита от снятия компонента с производства.



Как с нами связаться

Телефон: 8 (812) 309 58 32 (многоканальный)

Факс: 8 (812) 320-02-42

Электронная почта: org@eplast1.ru

Адрес: 198099, г. Санкт-Петербург, ул. Калинина, дом 2, корпус 4, литера А.