

REVISIONS					
P	LTR	DESCRIPTION	DATE	OWN	APVD
U2		REVISED PER ECO-11-004587	11MAR11	RK	HMR
V		REVISED PER ECO-17-002209	11APR2017	RS	MM

- 1 .00076[.000030] GOLD IN THE CONTACT AREA, .00254[.000100] MATTE TIN-LEAD ON REMAINDER OF CONTACT, ALL OVER .00127[.000050] NICKEL.
- 2 POINT OF MEASUREMENT FOR PLATING THICKNESS.
- 3 THE NOTED DIMENSIONS APPLY AT THE INTERSECTION OF THE POST AND THE HOUSING.
- 4 ON ASSEMBLIES WITH FOUR OR MORE POSITIONS, TWO POLARIZATION SLOTS. ON ASSEMBLIES WITH TWO OR THREE POSITIONS, ONE POLARIZATION SLOT.
- 5 .00076[.000030] GOLD IN THE CONTACT AREA, .00254[.000100] MATTE TIN ON REMAINDER OF CONTACT, ALL OVER .00127[.000050] NICKEL.
- 6 HIGH TEMPERATURE CONFIGURATION
- 7 STANDOFFS NOT PRESENT ON UNDERSIDE OF ASSEMBLY
- 8 OBSOLETE PARTS: OBSOLETE CIS STREAMLINING PER D.RENAUD/D.SINISI

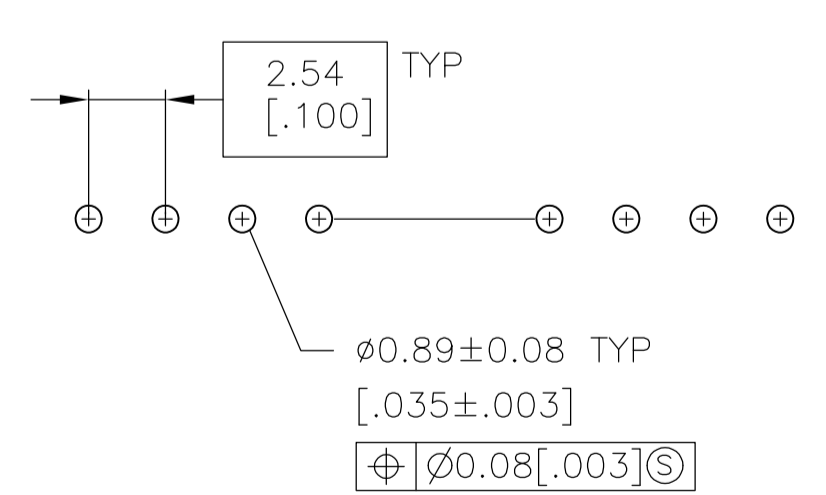
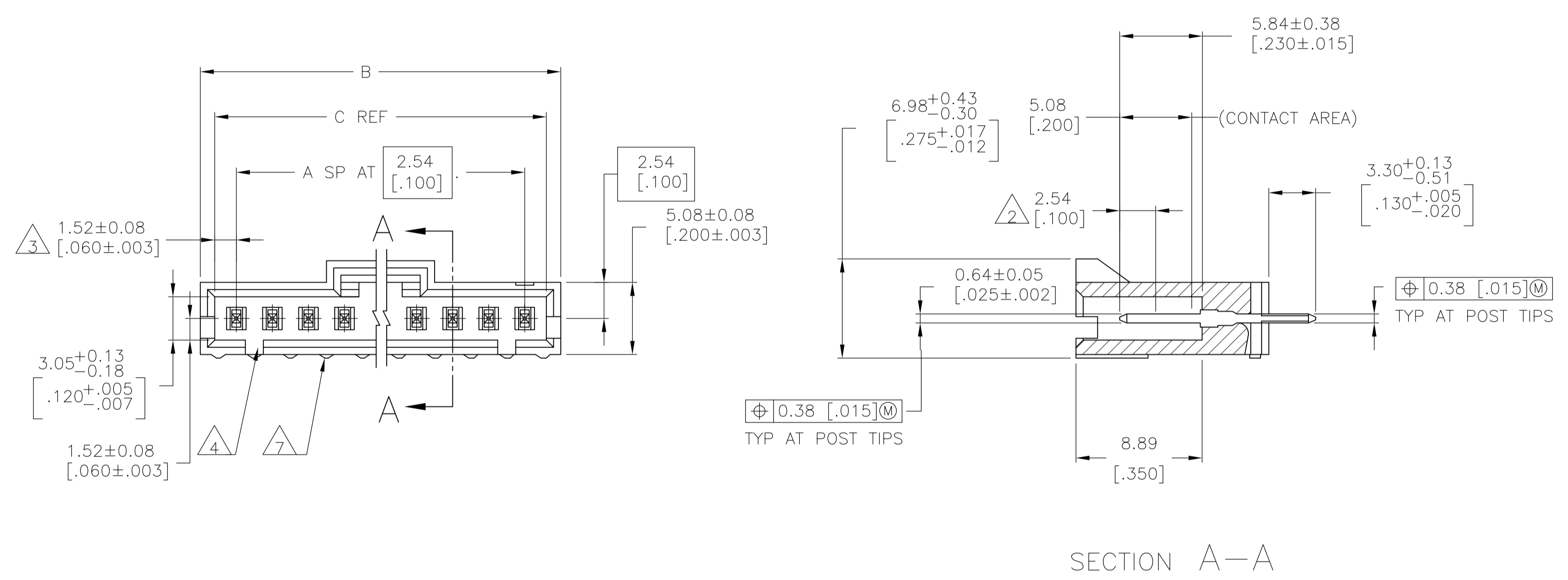
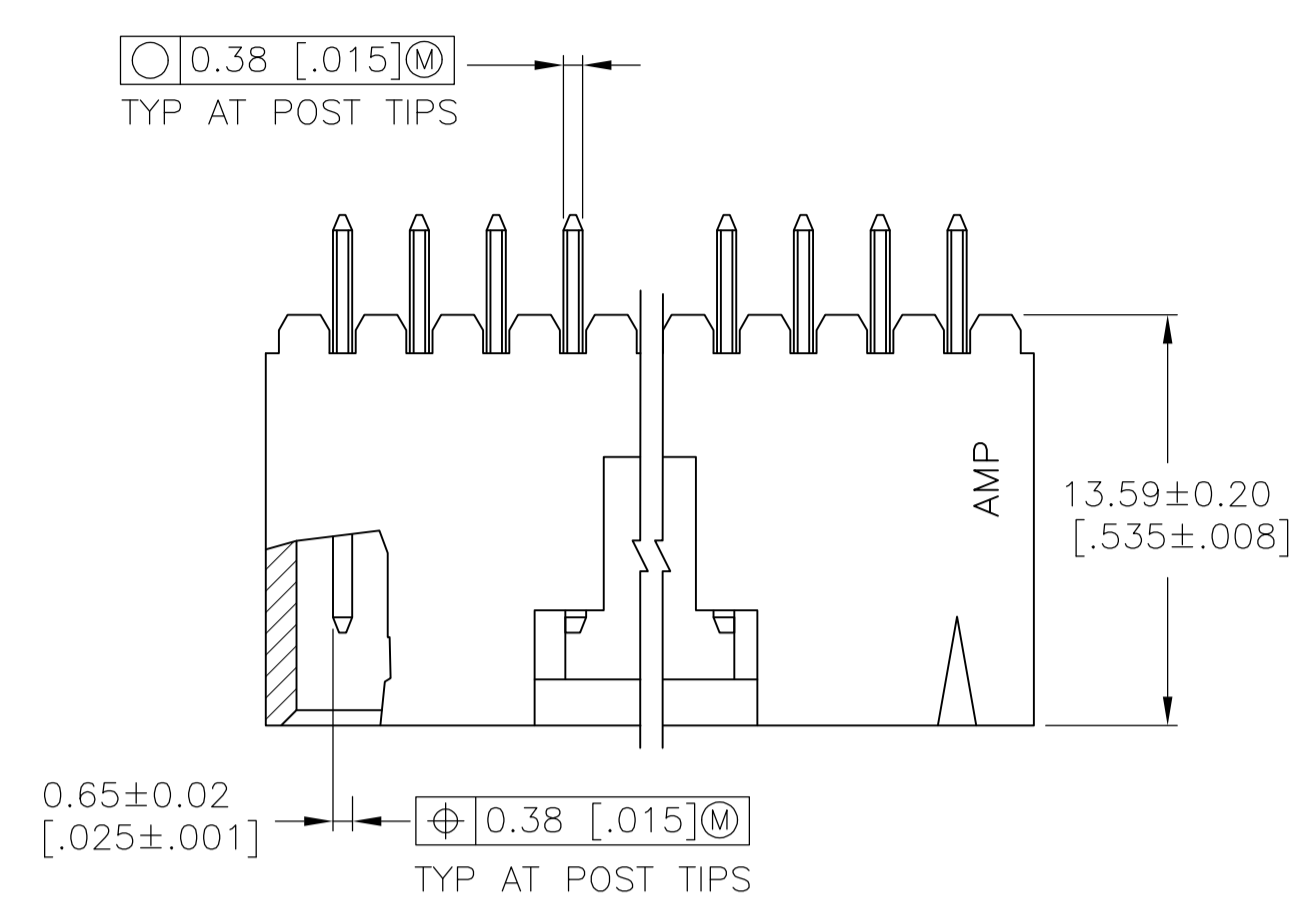

RECOMMENDED HOLE LAYOUT

REMARKS	PLATING	C	B	A	NO. OF POSN	PART NO.
		64.01 [2.520]	65.91 [2.595]	24	25	2-103735-4
8 OBSOLETE		61.47 [2.420]	63.37 [2.495]	23	24	-2-103735-3
8 OBSOLETE		58.93 [2.320]	60.83 [2.395]	22	23	-2-103735-2
8 OBSOLETE		56.39 [2.220]	58.29 [2.295]	21	22	-2-103735-1
8 OBSOLETE		53.85 [2.120]	55.75 [2.195]	20	21	-2-103735-0
		51.31 [2.020]	53.21 [2.095]	19	20	1-103735-9
8 OBSOLETE		48.77 [1.920]	50.67 [1.995]	18	19	-1-103735-8
		46.23 [1.820]	48.13 [1.895]	17	18	1-103735-7
		43.69 [1.720]	45.59 [1.795]	16	17	1-103735-6
		41.15 [1.620]	43.05 [1.695]	15	16	1-103735-5
		38.61 [1.520]	40.51 [1.595]	14	15	1-103735-4
		36.07 [1.420]	37.97 [1.495]	13	14	1-103735-3
		33.53 [1.320]	35.43 [1.395]	12	13	1-103735-2
		30.99 [1.220]	32.89 [1.295]	11	12	1-103735-1
		28.45 [1.120]	30.35 [1.195]	10	11	1-103735-0
		25.91 [1.020]	27.81 [1.095]	9	10	103735-9
		23.37 [0.920]	25.27 [0.995]	8	9	103735-8
		20.83 [0.820]	22.73 [0.895]	7	8	103735-7
		18.29 [0.720]	20.19 [0.795]	6	7	103735-6
		15.75 [0.620]	17.65 [0.695]	5	6	103735-5
		13.21 [0.520]	15.11 [0.595]	4	5	103735-4
		10.67 [0.420]	12.57 [0.495]	3	4	103735-3
		8.13 [0.320]	10.03 [0.395]	2	3	103735-2
		5.59 [0.220]	7.49 [0.295]	1	2	103735-1

THIS DRAWING IS A CONTROLLED DOCUMENT.

DIMENSIONS: mm [INCHES]
 TOLERANCES UNLESS OTHERWISE SPECIFIED:
 0 PLC ± -
 1 PLC ± -
 2 PLC ± 0.13[.005]
 3 PLC ± -
 4 PLC ± -
 ANGLES ± -

MATERIAL: HOUSING: PLZ
 PLATE REMAIND: SP
 SPRING: BRASS
 CONTACTS: BRASS

FINISH: SEE TABLE

THIS DRAWING IS A CONTROLLED DOCUMENT. S. SHUEY 3-5-91
 CJK: L. CASTAGNA 3-27-91
 APVD: L. CASTAGNA 3-27-91
 NAME: HDR ASSY, VERT, SINGLE ROW
 PRODUCT SPEC: 2.54[.100] @, 0.64[.025] SQ POST, WITH PLZN & LATCHING, AMPMODU MTE
 APPLICATION SPEC: -
 SIZE: A1
 CAGE CODE: 00779
 DRAWING NO: 103735
 WEIGHT: -
 CUSTOMER DRAWING: -
 SCALE: 4:1
 SHEET: 1 OF 2
 REV: V

STC TE Connectivity

REVISIONS					
P	LTR	DESCRIPTION	DATE	DMN	APVD
		SEE SHEET 1	-	-	-

		△6	△7	△5	64.01 [2.520]	65.91 [2.595]	24	25	7-103735-4
△8	OBSOLETE	△6	△7	△5	61.47 [2.420]	63.37 [2.495]	23	24	-7-103735-3
△8	OBSOLETE	△6	△7	△5	58.93 [2.320]	60.83 [2.395]	22	23	-7-103735-2
△8	OBSOLETE	△6	△7	△5	56.39 [2.220]	58.29 [2.295]	21	22	-7-103735-1
△8	OBSOLETE	△6	△7	△5	53.85 [2.120]	55.75 [2.195]	20	21	-7-103735-0
		△6	△7	△5	51.31 [2.020]	53.21 [2.095]	19	20	6-103735-9
△8	OBSOLETE	△6	△7	△5	48.77 [1.920]	50.67 [1.995]	18	19	-6-103735-8
△8	OBSOLETE	△6	△7	△5	46.23 [1.820]	48.13 [1.895]	17	18	-6-103735-7
		△6	△7	△5	43.69 [1.720]	45.59 [1.795]	16	17	6-103735-6
		△6	△7	△5	41.15 [1.620]	43.05 [1.695]	15	16	6-103735-5
		△6	△7	△5	38.61 [1.520]	40.51 [1.595]	14	15	6-103735-4
		△6	△7	△5	36.07 [1.420]	37.97 [1.495]	13	14	6-103735-3
△8	OBSOLETE	△6	△7	△5	33.53 [1.320]	35.43 [1.395]	12	13	-6-103735-2
		△6	△7	△5	30.99 [1.220]	32.89 [1.295]	11	12	6-103735-1
		△6	△7	△5	28.45 [1.120]	30.35 [1.195]	10	11	6-103735-0
		△6	△7	△5	25.91 [1.020]	27.81 [1.095]	9	10	5-103735-9
		△6	△7	△5	23.37 [.920]	25.27 [0.995]	8	9	5-103735-8
		△6	△7	△5	20.83 [.820]	22.73 [.895]	7	8	5-103735-7
		△6	△7	△5	18.29 [.720]	20.19 [.795]	6	7	5-103735-6
		△6	△7	△5	15.75 [.620]	17.65 [.695]	5	6	5-103735-5
		△6	△7	△5	13.21 [.520]	15.11 [.595]	4	5	5-103735-4
		△6	△7	△5	10.67 [.420]	12.57 [.495]	3	4	5-103735-3
		△6	△7	△5	8.13 [.320]	10.03 [.395]	2	3	5-103735-2
		△6	△7	△5	5.59 [.220]	7.49 [.295]	1	2	5-103735-1
	REMARKS		PLATING		C	B	A	NO. OF POSN	PART NO.

THIS DRAWING IS A CONTROLLED DOCUMENT.		DMN S. SHUEY 3-5-91	 TE Connectivity
DIMENSIONS: mm [INCHES]		CHK L. CASTAGNA 3-27-91	
TOLERANCES UNLESS OTHERWISE SPECIFIED:		APVD L. CASTAGNA 3-27-91	NAME
0. PLC ± - 1. PLC ± - 2. PLC ± - 3. PLC ± - 4. PLC ± - ANGLES ± -		PRODUCT SPEC	HDR ASSY, VERT, SINGLE ROW 2.54[.100] @ 0.64[.025] SQ POST, WITH PLZN & LATCHING, AMPMODU MTE
MATERIAL: HOUSING: TAMP REMOVAL (UP) COLOUR-BLACK CONTACTS: BRASS		FINISH: SEE TABLE	APPLICATION SPEC
WEIGHT		SIZE: A1	RESTRICTED TO
CUSTOMER DRAWING		SCALE: 4:1	SHEET 2 OF 2
		DRAWING NO: 00779	REV V
		DRAWING NO: 103735	



Компания «ЭлектроПласт» предлагает заключение долгосрочных отношений при поставках импортных электронных компонентов на взаимовыгодных условиях!

Наши преимущества:

- Оперативные поставки широкого спектра электронных компонентов отечественного и импортного производства напрямую от производителей и с крупнейших мировых складов;
- Поставка более 17-ти миллионов наименований электронных компонентов;
- Поставка сложных, дефицитных, либо снятых с производства позиций;
- Оперативные сроки поставки под заказ (от 5 рабочих дней);
- Экспресс доставка в любую точку России;
- Техническая поддержка проекта, помощь в подборе аналогов, поставка прототипов;
- Система менеджмента качества сертифицирована по Международному стандарту ISO 9001;
- Лицензия ФСБ на осуществление работ с использованием сведений, составляющих государственную тайну;
- Поставка специализированных компонентов (Xilinx, Altera, Analog Devices, Intersil, Interpoint, Microsemi, Aeroflex, Peregrine, Syfer, Eurofarad, Texas Instrument, Miteq, Cobham, E2V, MA-COM, Hittite, Mini-Circuits, General Dynamics и др.);

Помимо этого, одним из направлений компании «ЭлектроПласт» является направление «Источники питания». Мы предлагаем Вам помощь Конструкторского отдела:

- Подбор оптимального решения, техническое обоснование при выборе компонента;
- Подбор аналогов;
- Консультации по применению компонента;
- Поставка образцов и прототипов;
- Техническая поддержка проекта;
- Защита от снятия компонента с производства.



Как с нами связаться

Телефон: 8 (812) 309 58 32 (многоканальный)

Факс: 8 (812) 320-02-42

Электронная почта: org@eplast1.ru

Адрес: 198099, г. Санкт-Петербург, ул. Калинина, дом 2, корпус 4, литера А.