

SF2170D

**165 MHz
SAW Filter**

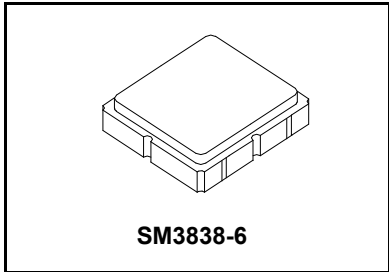

- **Low Insertion Loss**
- **3.8 X 3.8 X 1.0 mm Surface Mount Case**
- **Single-Ended Input/Output**
- **Complies with Directive 2002/95/EC (RoHS)**

Absolute Maximum Ratings

Rating	Value	Units
Maximum Incident Power in Passband	+10	dBm
Maximum DC Voltage Between any 2 Terminals	30	VDC
Storage Temperature Range in Tape and Reel	-40 to +85	°C
Suitable for Lead-free Soldering - Maximum Soldering Profile	260°C for 30 s	

Electrical Characteristics

Characteristic	Sym	Notes	Min	Typ	Max	Units
Center Frequency	f_c	1		165		MHz
Source Impedance to Matching Network (single ended)				50		Ω
Load Impedance to Matching Network (single ended)				50		Ω
Passband Width			20	22		MHz
Rejection Referenced to Minimum Insertion Loss:						dB
10 MHz to 110 MHz			35	40		
127 MHz to 149 MHz			10	15		
190 to 210 MHz			30	40		
210 to 450 MHz			40	45		
Maximum Insertion Loss				9	10	dB
Insertion Loss Variation over -40 to 85 °C					1	dB
Amplitude Variation over 20 MHz Passband				1.0	1.5	dB _{p-p}
Group Delay Variation over 20 MHz Passband				40	80	ns _{p-p}
Absolute Group Delay at f_c				0.33		μ s
Input/Output Return Loss into Matching over 20 MHz BW			6	8		dB
Operating Temperature			-40		+85	°C

Case Style	SM3838-6 3.8 x 3.8 mm Nominal Footprint	
Lid Symbolization (Y=year, WW=week, S=shift) dot=pin 1 indicator	865, YWWS	
Standard Reel Quantity	Reel Size 7 Inch	1000 Pieces/Reel
	Reel Size 13 Inch	3000 Pieces/Reel

CAUTION: Electrostatic Sensitive Device. Observe precautions for handling.

NOTES:

1. Unless noted otherwise, all specifications apply over the operating temperature range with filter soldered to the specified demonstration board with impedance matching to 50 Ω and measured with 50 Ω network analyzer.
2. Unless noted otherwise, all frequency specifications are referenced to the nominal center frequency, f_c .
3. Rejection is measured as attenuation below the minimum IL point in the passband. Rejection in final user application is dependent on PCB layout and external impedance matching design. See Application Note No. 42 for details.
4. The design, manufacturing process, and specifications of this filter are subject to change.
5. Either Port 1 or Port 2 may be used for either input or output in the design. However, impedances and impedance matching may vary between Port 1 and Port 2, so that the filter must always be installed in one direction per the circuit design.
6. US and international patents may apply.
7. Murata, stylized Murata logo, and Murata N.A., Inc. are registered trademarks of Murata Manufacturing Co., Ltd.

Broadband Filter Response and Return Loss (through matching network)

17 Sep 2008 06:49:06

CH1 LOG 5 dB/ REF 0 dB
S11 3 : 5.2056 dB 20 .000 000 MHz

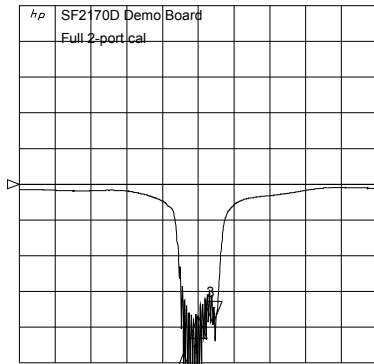

CH1 Markers
Δ REF=2
mean : -20 .948 dB
s. dev : 5.2747 dB
p-p : 29.591 dB

CH3 LOG 5 dB/ REF 0 dB
S22 3 : -3.5658 dB 20 .000 000 MHz

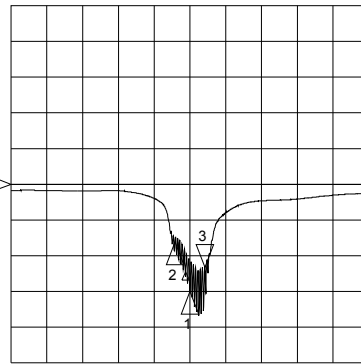

CH3 Markers
Δ REF=2
mean : -12 .005 dB
s. dev : 2.7750 dB
p-p : 11.003 dB

CENTR 165 .000 MHz Δ SPAN 240 .000 MHz

CENTR 165 .000 MHz SPAN 240 .000 MHz

CH2 S21 LOG 10 dB/ REF -55 dB 1 : -9.8909 dB 158 .700 000 MHz

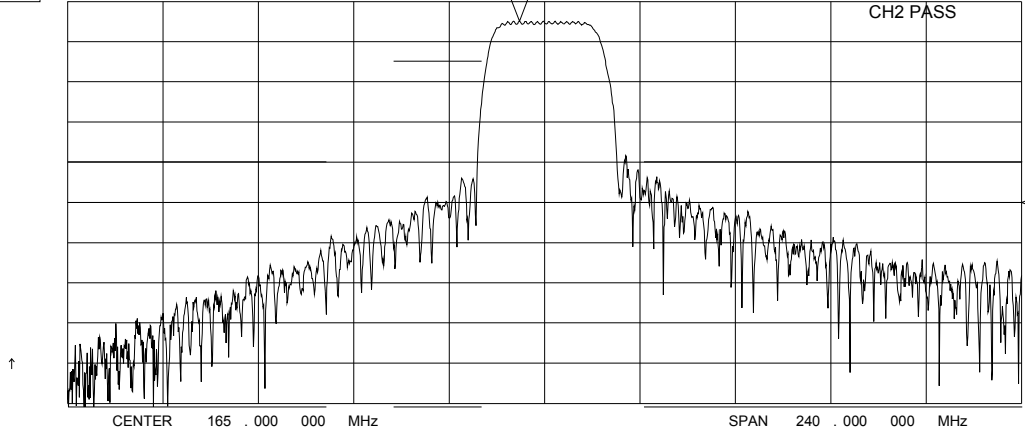

Max

↑

CENTR 165 .000 000 MHz

SPAN 240 .000 000 MHz

Passband Amplitude and Impedance Detail

17 Sep 2008 14:04:20

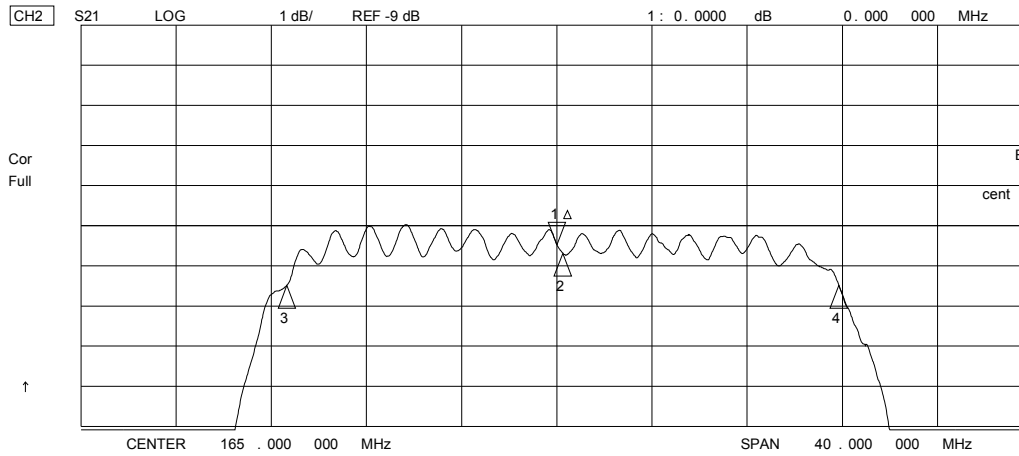
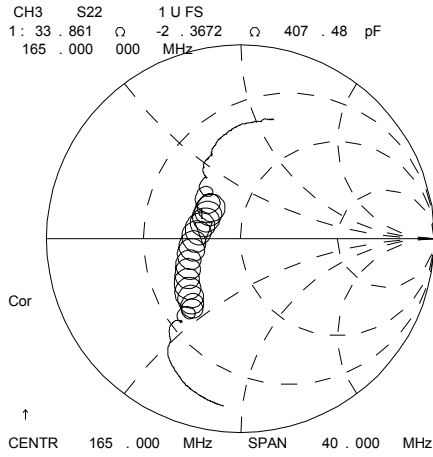
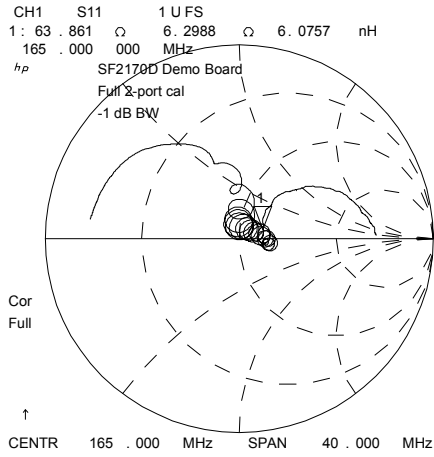

CH2 Markers
 Δ REF=1
 BW: 23 . 196777 MHz
 cent : 165 . 256979 MHz
 Q: 7 . 1241
 1 loss : -9 . 4834 dB

Passband Group Delay and Amplitude Ripple

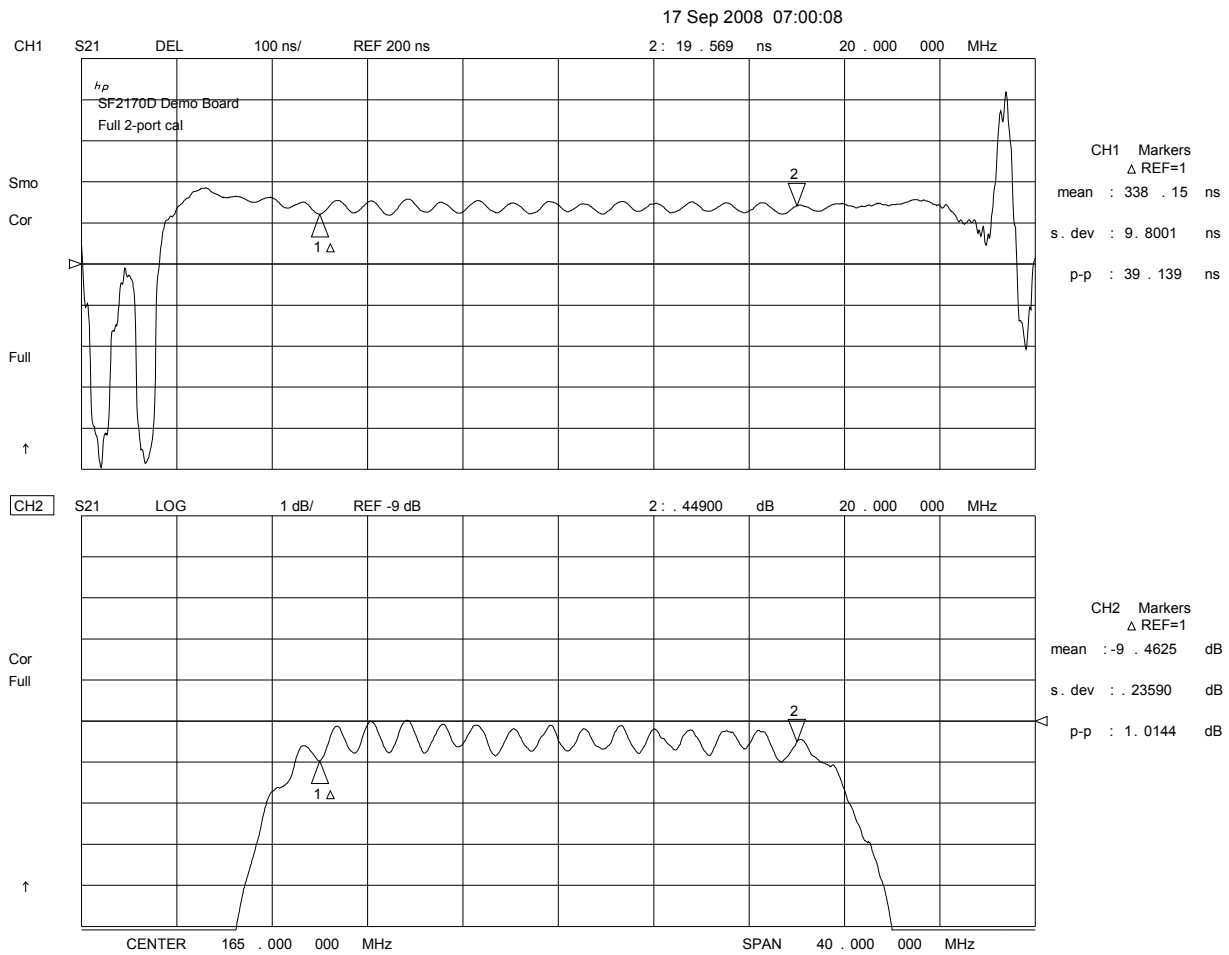

SF2170D Demo Circuit

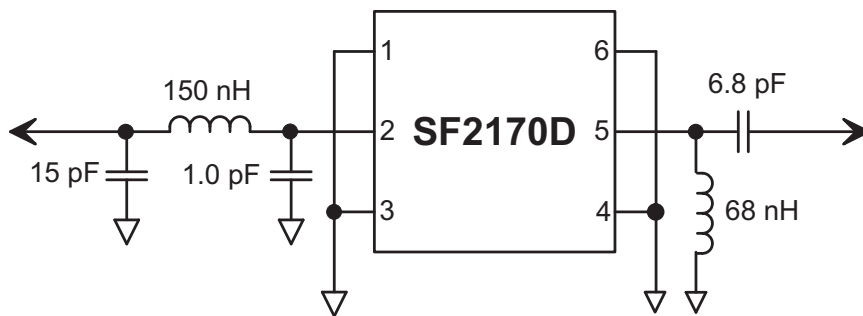

SM3838-6 Case

6-Terminal Ceramic Surface-Mount Case

3.8 X 3.8 mm Nominal Footprint

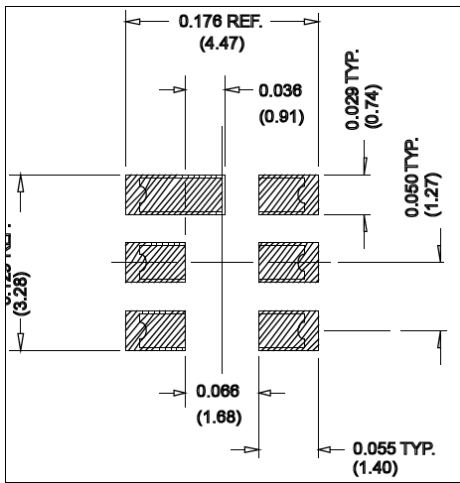
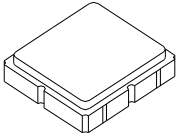

PCB Footprint

Case Dimensions						
Dimension	mm			Inches		
	Min	Nom	Max	Min	Nom	Max
A	3.60	3.80	4.0	0.14	0.15	0.16
B	3.60	3.80	4.0	0.14	0.15	0.16
C	1.30	1.50	1.70	0.05	0.06	0.067
D	0.95	1.10	1.25	0.037	0.043	0.05
E	2.39	2.54	2.69	0.090	0.10	0.110
G	0.90	1.0	1.10	0.035	0.04	0.043
H	1.90	2.0	2.10	0.75	0.08	0.83
I	0.50	0.6	0.70	0.020	0.024	0.028
J	1.70	1.8	1.90	0.067	0.07	0.075

Electrical Connections		
Connection	Terminals	
Port 1	Single-ended Input	2
Port 2	Single-ended Output	5
	Ground	All others

Single Ended Operation Only

Dot indicates Pin 1

Materials	
Solder Pad Plating	0.3 to 1.0 μm Gold over 1.27 to 8.89 μm Nickel
Lid Plating	2.0 to 3.0 μm Nickel
Body	Al_2O_3 Ceramic
Pb Free	

TOP VIEW

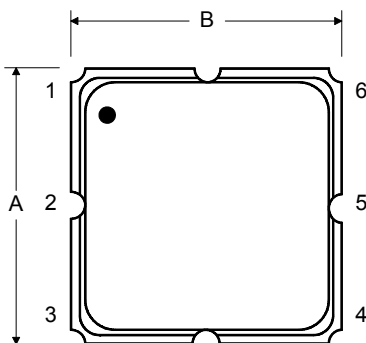

BOTTOM VIEW

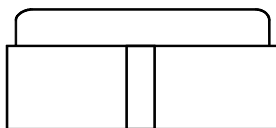
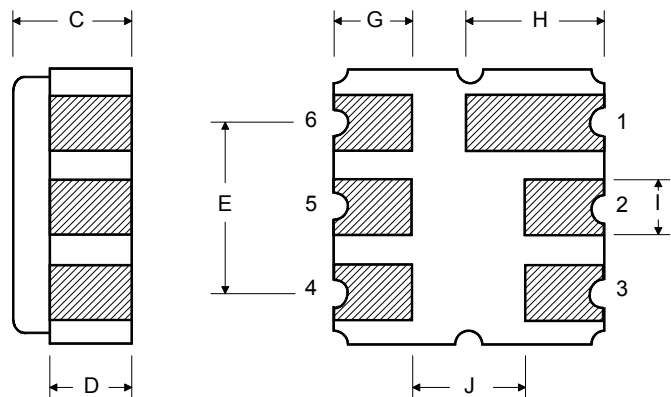



Компания «ЭлектроПласт» предлагает заключение долгосрочных отношений при поставках импортных электронных компонентов на взаимовыгодных условиях!

Наши преимущества:

- Оперативные поставки широкого спектра электронных компонентов отечественного и импортного производства напрямую от производителей и с крупнейших мировых складов;
- Поставка более 17-ти миллионов наименований электронных компонентов;
- Поставка сложных, дефицитных, либо снятых с производства позиций;
- Оперативные сроки поставки под заказ (от 5 рабочих дней);
- Экспресс доставка в любую точку России;
- Техническая поддержка проекта, помощь в подборе аналогов, поставка прототипов;
- Система менеджмента качества сертифицирована по Международному стандарту ISO 9001;
- Лицензия ФСБ на осуществление работ с использованием сведений, составляющих государственную тайну;
- Поставка специализированных компонентов (Xilinx, Altera, Analog Devices, Intersil, Interpoint, Microsemi, Aeroflex, Peregrine, Syfer, Eurofarad, Texas Instrument, Miteq, Cobham, E2V, MA-COM, Hittite, Mini-Circuits, General Dynamics и др.);

Помимо этого, одним из направлений компании «ЭлектроПласт» является направление «Источники питания». Мы предлагаем Вам помощь Конструкторского отдела:

- Подбор оптимального решения, техническое обоснование при выборе компонента;
- Подбор аналогов;
- Консультации по применению компонента;
- Поставка образцов и прототипов;
- Техническая поддержка проекта;
- Защита от снятия компонента с производства.



Как с нами связаться

Телефон: 8 (812) 309 58 32 (многоканальный)

Факс: 8 (812) 320-02-42

Электронная почта: org@eplast1.ru

Адрес: 198099, г. Санкт-Петербург, ул. Калинина, дом 2, корпус 4, литера А.