

MEAS PI WEATHER SHIELD

Digital Humidity Sensor

Digital Pressure Sensor

Digital Temperature Sensor

Digital Thermopile Sensor

General Description

The MEAS Pi weather shield provides the necessary hardware to interface the HTU21D digital relative humidity sensor; MS5637 digital barometric pressure sensor; temperature system sensor (TSYS)01 digital temperature sensor; TSD305-1C55 digital thermopile sensor to any system that utilizes Raspberry Pi compatible expansion ports configurable for I²C communication.

The HTU21D sensor is a self-contained humidity and temperature sensor that is fully calibrated during manufacturing. The sensor can operate from 1.5V to 3.6V, has selectable resolution, low battery detection, and checksum capability. The HTU21D has a low power stand-by mode for power-sensitive applications.

The MS5637 sensor is a self-contained pressure and temperature sensor that is fully calibrated during manufacturing. The sensor can operate from 1.5V to 3.6V. The sensor module includes a high-linearity pressure sensor and an ultra-low power 24-bits $\Delta\Sigma$ ADC with internal factory-calibrated coefficients.

The temperature system sensor -TSYS-01 series is a self-contained temperature sensor that is fully calibrated during manufacturing. The sensor can operate from 2.2V to 3.6V. The TSYS01 has a low power stand-by mode for power-sensitive applications.

The TSD305-1C55 is a contactless temperature measurement system located in a TO5 package. The TSD includes an infrared sensor (thermopile) and a sensor signal conditioner.

Specifications

HTU21D

- Measures relative humidity from 0% to 100%
- Measures temperature from -40°C to 125°C
- I²C communication
- Fully calibrated
- Fast response time
- Selectable resolution 8/12-bits resolution for humidity; 11/14-bits resolution for temperature)
- Very low power consumption

MS5637

- Measures pressure from 300 mbar to 1200 mbar
- Measures temperature from -40°C to 125°C
- I²C communication
- Fully calibrated
- Fast response time
- Very low power consumption

TSYS01

- Measures temperature from -40°C to 125°C
- I²C communication
- Fully calibrated
- Fast response time
- Very low power consumption
- 24/16-bits resolution for temperature

TSD305-1C55

- Measures temperature from 0°C to 100°C
- I²C communication
- Contactless temperature measurement
- Fully calibrated
- Up to ±1°C accuracy
- Operating Temperature Range: -10°C ... +85°C
- Low current consumption

Performance

- 0% to 100% relative humidity range (HTU21D sensor)
- Operating pressure range: 300 to 1200 mbar (MS5637 sensor)
- Measures temperature from -40°C to 125°C, accuracy from 0.1°C to 0.5°C (TSYS0101 sensor)
- Contactless temperature measurement from 0°C to 100°C (TSD305-1C55)

MEAS PI WEATHER SHIELD

Digital Weather-Shield Sensor

Schematic

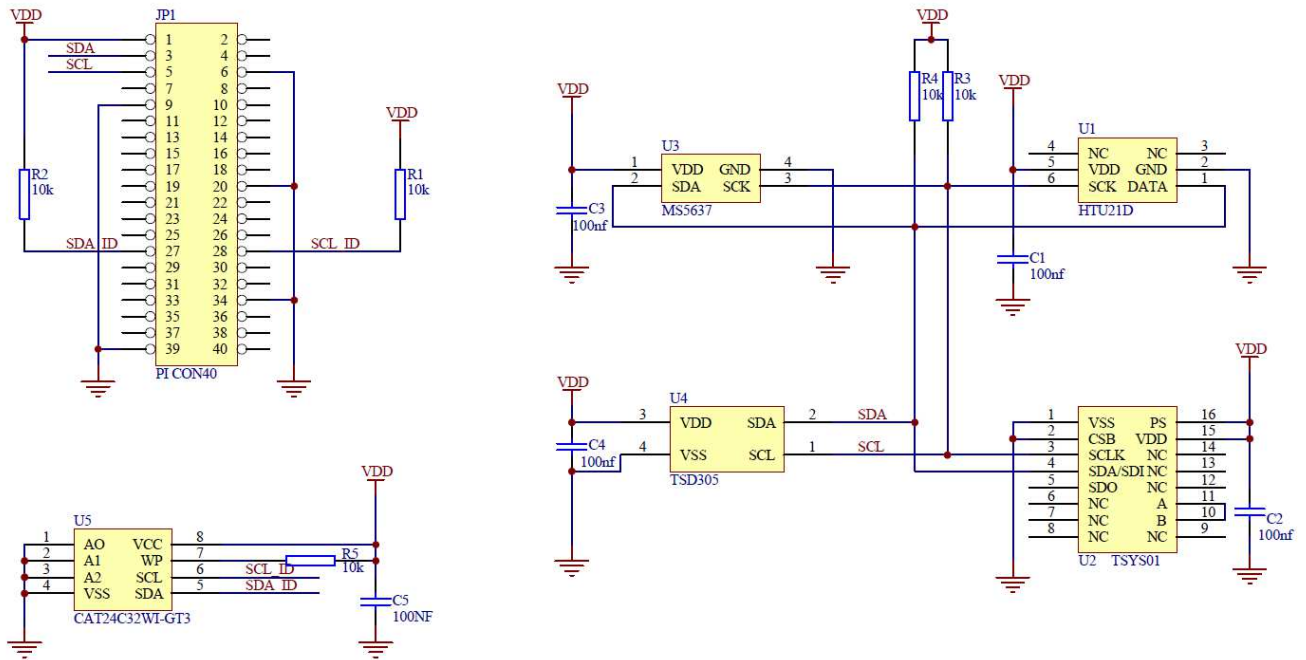

Dimensions (mm)

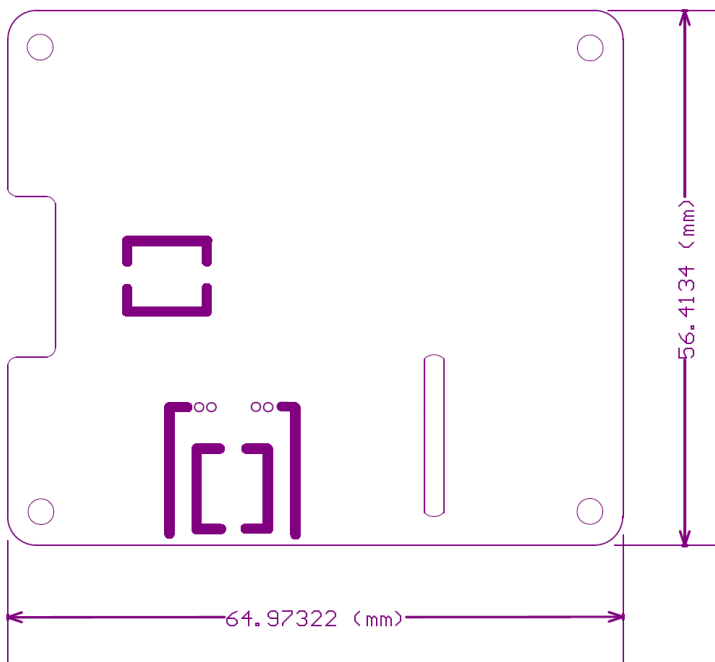

MEAS PI WEATHER SHIELD

Digital Weather-Shield Sensor

Detailed Description

Standard Interface for the Pi Weather Shield:

The Pi weather shield is compatible with standard Raspberry Pi 2/3 header.

TSYS01 sensor can pick off from the weather shield board:

The TSYS01 sensor can pick off from the board, there are only small connection from the board with the TSYS01 sensor (with small PCB), the sensor with small PCB can be cut off from the main weather PCB then solder four wires to connect the sensor board and the weather board.

Reference Material

Detailed information regarding operation of the IC:

- [HTU21D Datasheet](#)
- [MS5637 Datasheet](#)
- [TSYS01 datasheet](#)
- [TSD305-1C55 Datasheet](#)

Python framework and example source code available on [Github](#).

IBM Bluemix recipe available on [developerWorks](#).

Ordering Information

Description	Part Number
PI WEATHER-SHIELD	DPP904R000

te.com/sensorsolutions

MEAS, TE Connectivity and TE connectivity (logo) are trademarks. All other logos, products and/or company names referred to herein might be trademarks of their respective owners.

Raspberry Pi is a trademark of the Raspberry Pi Foundation.
IBM®, Bluemix® and developerWorks® are trademarks of International Business Machines Corporation.
GitHub® is a trademark of GitHub, Inc.
Python is a trademark.

The information given herein, including drawings, illustrations and schematics which are intended for illustration purposes only, is believed to be reliable. However, TE Connectivity makes no warranties as to its accuracy or completeness and disclaims any liability in connection with its use. TE Connectivity's obligations shall only be as set forth in TE Connectivity's Standard Terms and Conditions of Sale for this product and in no case will TE Connectivity be liable for any incidental, indirect or consequential damages arising out of the sale, resale, use or misuse of the product. Users of TE Connectivity products should make their own evaluation to determine the suitability of each such product for the specific application.

© 2016 TE Connectivity Ltd. family of companies All Rights Reserved.

PRODUCT SHEET

MEAS France SAS,
a TE Connectivity company.
Impasse Jeanne Benozzi CS 83 163
31027 Toulouse Cedex 3, FRANCE
Tel: +33 (0) 5 820 822 02
Fax: +33 (0) 5 820 821 51
customercare.ilse@te.com



Компания «ЭлектроПласт» предлагает заключение долгосрочных отношений при поставках импортных электронных компонентов на взаимовыгодных условиях!

Наши преимущества:

- Оперативные поставки широкого спектра электронных компонентов отечественного и импортного производства напрямую от производителей и с крупнейших мировых складов;
- Поставка более 17-ти миллионов наименований электронных компонентов;
- Поставка сложных, дефицитных, либо снятых с производства позиций;
- Оперативные сроки поставки под заказ (от 5 рабочих дней);
- Экспресс доставка в любую точку России;
- Техническая поддержка проекта, помощь в подборе аналогов, поставка прототипов;
- Система менеджмента качества сертифицирована по Международному стандарту ISO 9001;
- Лицензия ФСБ на осуществление работ с использованием сведений, составляющих государственную тайну;
- Поставка специализированных компонентов (Xilinx, Altera, Analog Devices, Intersil, Interpoint, Microsemi, Aeroflex, Peregrine, Syfer, Eurofarad, Texas Instrument, Miteq, Cobham, E2V, MA-COM, Hittite, Mini-Circuits, General Dynamics и др.);

Помимо этого, одним из направлений компании «ЭлектроПласт» является направление «Источники питания». Мы предлагаем Вам помощь Конструкторского отдела:

- Подбор оптимального решения, техническое обоснование при выборе компонента;
- Подбор аналогов;
- Консультации по применению компонента;
- Поставка образцов и прототипов;
- Техническая поддержка проекта;
- Защита от снятия компонента с производства.



Как с нами связаться

Телефон: 8 (812) 309 58 32 (многоканальный)

Факс: 8 (812) 320-02-42

Электронная почта: org@eplast1.ru

Адрес: 198099, г. Санкт-Петербург, ул. Калинина, дом 2, корпус 4, литера А.