

**SINGLE BIT DUAL POWER SUPPLY TRANSLATING
TRANSCEIVER WITH 3 STATE OUTPUTS**

Description

The 74AVC1T45 is a single bit, dual supply transceiver with tri-state outputs suitable for transmitting a single logic bit across different voltage domains. The A input/output pin is designed to track V_{CCA} while the B input/output tracks V_{CCB} . This arrangement allows for universal low-voltage translation between any voltages from 1.2V to 3.6V. The Direction pin (DIR) controls the direction of the transceiver and in a logic voltage related to V_{CCA} . When a high logic level is applied to DIR the A pin becomes an input and the B pin becomes the output. Conversely the roles of A and B are reversed when DIR is asserted low.

The tri-state feature occurs when either of the power supply voltages are zero. This is also an Ioff feature and allows for the output to remain in a high-impedance state with both power supplies at 0V preventing damaging backflow currents and providing power down electrical isolation up to 3.6 V as not to interfere with any logic activity on pin A or B.

Pin Assignments

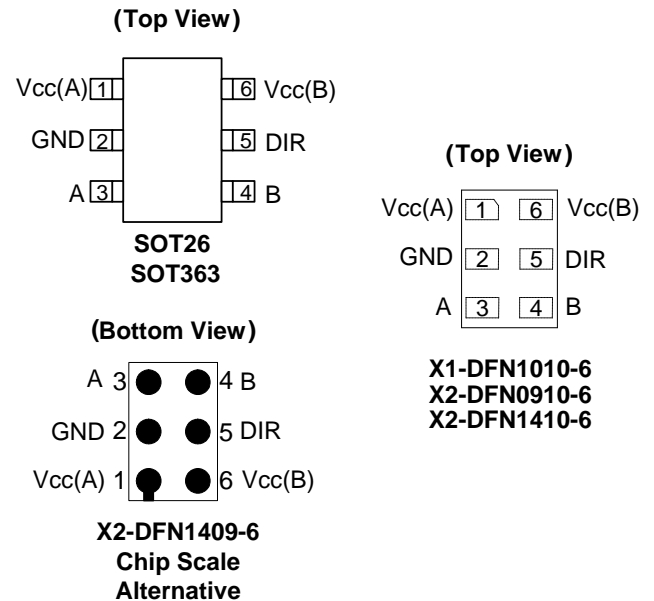

Features

- Wide Supply Voltage Range:
 - $V_{CC(A)}$: from 1.2V to 3.6V
 - $V_{CC(B)}$: from 1.2V to 3.6V
- ± 12 mA Output Drive at 3.3V
- High Noise Immunity—(100mV Hysteresis Typical)
- I_{OFF} Supports Partial-Power-Down Mode Operation
- I_{OFF} Controlled by Either V_{CC} at 0V
- Inputs Accept up to 4.6V
- ESD Protection Exceeds JESD 22
 - 200-V Machine Model (A115)
 - 2000-V Human Body Model (A114)
 - 1000 V Charged Device Model (C101)
- Latch-Up Exceeds 100mA per JESD 78, Class I
- X2-DFN1409-6 Package Designed as a Direct Replacement for Chip-Scale Packaging.
- **Totally Lead-Free & Fully RoHS Compliant (Notes 1 & 2)**
- **Halogen and Antimony Free. "Green" Device (Note 3)**

Applications

- Voltage Level Translation
Well Suited to Join Logic Types Operating at Different Voltages
- Power Down Signal Isolation
If Either Voltage Domain is Turned off the Signal is Isolated and There is no Loading on Signal Lines
- Wide Array of Products, such as:
 - Cell Phones, Tablets, E-Readers
 - PCs, Notebooks, Netbooks, Ultrabooks
 - Networking, Routers, Gateways
 - Computer Peripherals, Hard Drives, CD/DVD ROMs
 - TVs, DVDs, DVRs, Set Top Boxes
 - Personal Navigation/GPS
 - MP3 players, Cameras, Video Recorders

Notes: 1. No purposely added lead. Fully EU Directive 2002/95/EC (RoHS), 2011/65/EU (RoHS 2) & 2015/863/EU (RoHS 3) compliant.
 2. See <https://www.diodes.com/quality/lead-free/> for more information about Diodes Incorporated's definitions of Halogen- and Antimony-free, "Green" and Lead-free.
 3. Halogen- and Antimony-free "Green" products are defined as those which contain <900ppm bromine, <900ppm chlorine (<1500ppm total Br + Cl) and <1000ppm antimony compounds.

Ordering Information

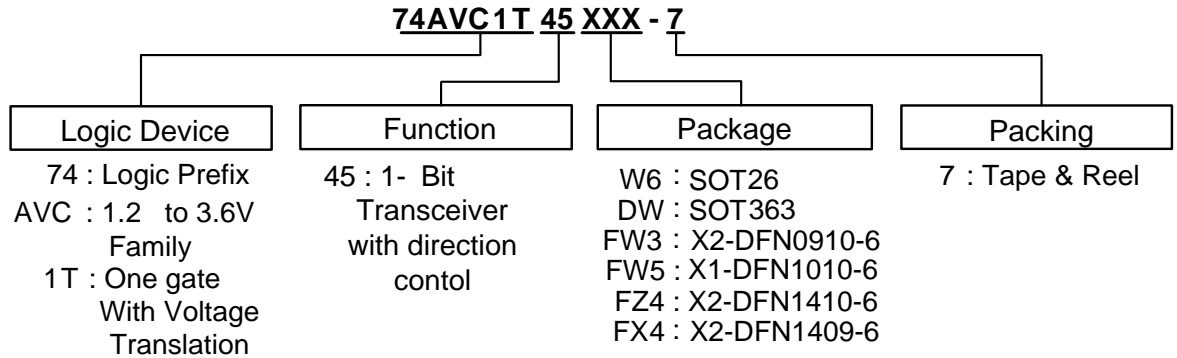

Part Number	Package Code	Packaging	7" Tape and Reel (Note 7)	
			Quantity	Part Number Suffix
74AVC1T45W6-7	W6	SOT26	3000/Tape & Reel	-7
74AVC1T45DW-7	DW	SOT363	3000/Tape & Reel	-7
74AVC1T45FW3-7	FW3	X2-DFN0910-6	5000/Tape & Reel	-7
74AVC1T45FW5-7	FW5	X1-DFN1010-6	5000/Tape & Reel	-7
74AVC1T45FZ4-7	FZ4	X2-DFN1410-6	5000/Tape & Reel	-7
74AVC1T45FX4-7	FX4	X2-DFN1409-6	5000/Tape & Reel	-7

Notes: 4. Taping orientation is located on our website at <https://www.diodes.com/assets/Packaging-Support-Docs/Ap02007.pdf>.

Pin Descriptions

Pin Name	Pin	Function
VCC(A)	1	Supply for I/O pin A and Reference for DIR
GND	2	Ground
A	3	Data Input/Output
B	4	Data Input/Output
DIR	5	Direction Control
VCC(B)	6	Supply for I/O pin B

Function Table

Supply voltage	Input	Input/Output	
$V_{CC(A)}, V_{CC(B)}$	DIR (Direction Pin)	A	B
1.2 V to 3.6 V	L	A = B	Input
1.2 V to 3.6 V	H	Input	B = A
GND	X	Z	Z

Logic Diagram

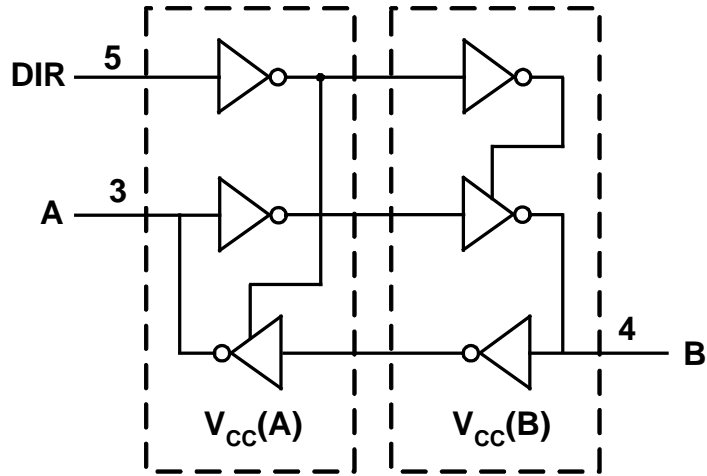

Absolute Maximum Ratings (Note 5) (@T_A = +25°C, unless otherwise specified.)

Symbol	Parameter	Rating	Unit
ESD HBM	Human Body Model ESD Protection	2	kV
ESD CDM	Charged Device Model ESD Protection	1	kV
ESD MM	Machine Model ESD Protection	200	V
V _{CC(A)} , V _{CC(B)}	Supply Voltage Range	-0.5 to +4.6	V
V _I	Input Voltage Range	-0.5 to +4.6	V
V _O	Voltage Applied to Output in High Impedance or I _{OFF} State	-0.5 to +4.6	V
V _O	Voltage Applied to Output in High or Low State	A pin	-0.5 to V _{CC(A)} +0.5
		B pin	-0.5 to V _{CC(B)} +0.5
I _{IK}	Input Clamp Current V _I <0	-50	mA
I _{OK}	Output Clamp Current	-50	mA
I _O	Continuous Output Current	±50	mA
—	Continuous Current Through V _{CC} or GND	±100	mA
T _J	Operating Junction Temperature	-40 to +150	°C
T _{STG}	Storage Temperature	-65 to +150	°C

Note: 5. Stresses beyond the absolute maximum can result in immediate failure or reduced reliability. These are stress values and device operation should be within recommend values.

Recommended Operating Condition (Notes 6, 7 & 8) (@T_A = +25°C, unless otherwise specified.)

Symbol	Parameter		V _{CCI}	V _{CCO}	Min	Max	Units
V _{CC(A)}	Operating Voltage		—	—	1.2	3.6	V
V _{CC(B)}	Operating Voltage		—	—	1.2	3.6	V
V _{IH}	High-Level Input Voltage	Data Inputs	1.2V to 1.95V	1.2V to 3.6V	0.65 × V _{CC(A)}	—	V
			1.95V to 2.7V	1.2V to 3.6V	1.6	—	
			2.7V to 3.6V	1.2V to 3.6V	2	—	
V _{IL}	Low-Level Input Voltage	Data Inputs	1.2V to 1.95V	1.2V to 3.6V	—	0.35 × V _{CC(A)}	V
			1.95V to 2.7V	1.2V to 3.6V	—	0.7	
			2.7V to 3.6V	1.2V to 3.6V	—	0.8	
V _{IH}	High-Level Input Voltage	DIR (Referenced to V _{CCA})	1.2V to 1.95V	1.2V to 3.6V	0.65 × V _{CC(B)}	—	V
			1.95V to 2.7V	1.2V to 3.6V	1.6	—	
			2.7V to 3.6V	1.2V to 3.6V	2	—	
V _{IL}	Low-Level Input Voltage	DIR (Referenced to V _{CCA})	1.2V to 1.95V	1.2V to 3.6V	—	0.35 × V _{CC(B)}	V
			1.95V to 2.7V	1.2V to 3.6V	—	0.7	
			2.7 to 3.6V	1.2V to 3.6V	—	0.8	
V _I	Input Voltage		—	—	0	3.6	V
V _O	Output Voltage	Active State	—	—	0	V _{CCO}	V
		3-State	—	—	0	3.6	V
I _{OH}	High-Level Output Current	1.2V to 3.6V	1.2V	—	-3	mA	
		1.2V to 3.6V	1.4V to 1.6V	—	-6		
		1.2V to 3.6V	1.65V to 1.95V	—	-8		
		1.2V to 3.6V	2.3V to 2.7V	—	-9		
		1.2V to 3.6V	3V to 3.6V	—	-12		
I _{OL}	Low-Level Output Current	1.2V to 3.6V	1.2V	—	3	mA	
		1.2V to 3.6V	1.4V to 1.6V	—	6		
		1.2V to 3.6V	1.65V to 1.95V	—	8		
		1.2V to 3.6V	2.3V to 2.7V	—	9		
		1.2V to 3.6V	3V to 3.6V	—	12		
Δt/ΔV	Input Transition Rise or Fall Rate		1.2V to 3.6V	1.2V to 3.6V	—	5	ns/V
T _A	Operating Free-Air Temperature				-40	+85	°C

Note: 6. V_{CCO} is the V_{CC} associated with the output port.
7. V_{CCI} is the V_{CC} associated with the input port.
8. All unused inputs of the device must be held at V_{CCI} of GND.

Electrical Characteristics (Notes 9 & 10) (@T_A = +40°C to +85°C, unless otherwise specified.)

Symbol	Parameter	Test Conditions	V _{CC} (A)	V _{CC} (B)	T _A = +25°C			T _A = -40°C to +85°C		Unit	
					Min	Typ	Max	Min	Max		
V _{OH}	High Level Output Voltage	I _{OH} = -100μA	1.2V to 3.6V	1.2V to 3.6V	—	—	—	V _{CC} - 0.2	—	V	
		I _{OH} = -3mA	1.2V	1.2V	—	0.95	—	—	—		
		I _{OH} = -6mA	1.4V	1.4V	—	—	—	1.05	—		
		I _{OH} = -8mA	1.65V	1.65V	—	—	—	1.2	—		
		I _{OH} = -9mA	2.3V	2.3V	—	—	—	1.75	—		
		I _{OH} = -12mA	3V	3V	—	—	—	2.3	—		
V _{OL}	Low-Level Output Voltage	I _{OL} = 100μA	1.2V to 3.6V	1.2V to 3.6V	—	—	—	—	0.2	V	
		I _{OL} = 3mA	1.2V	1.2V	—	0.15	—	—	—		
		I _{OL} = 6mA	1.4V	1.4V	—	—	—	—	0.35		
		I _{OL} = 8mA	1.65V	1.65V	—	—	—	—	0.45		
		I _{OL} = 9mA	2.3V	2.3V	—	—	—	—	0.55		
		I _{OL} = 12mA	3V	3V	—	—	—	—	0.7		
I _I	Input Current	DIR	V _I = V _{CC} (A) or GND	1.2V to 3.6V	1.2V to 3.6V	-0.25	±0.25	0.25	-1	1	μA
I _{OFF}	Power Down Leakage Current	A Pin	V _I or V _O = 0V to 3.6V	0V	0V to 3.6V	-1	±0.1	1	-5	5	μA
		B Pin		0V to 3.6V	0V	-1	±0.1	1	-5	5	
I _{OZ}	3-State Leakage Current	B Pin	V _O = V _{CCO} or GND	0V	0V to 3.6V	-2.5	±0.5	2.5	-5	5	μA
		A Pin	V _I = V _{CCI} or GND	0V to 3.6V	0V	-2.5	±0.5	2.5	-5	5	
I _{CCA}	Supply Current	V _I = V _{CCI} or GND I _O = 0	1.2 to 3.6V	11.2V to 3.6V	—	—	—	—	—	10	μA
			3.6V	0V	—	—	—	—	—	-2	
			0V	3.6V	—	—	—	—	—	10	
I _{CCB}	Supply Current	V _I = V _{CCI} or GND I _O = 0	1.2V to 3.6V	1.2V to 3.6V	—	—	—	—	—	10	μA
			0V	3.6V	—	—	—	—	—	10	
			3.6V	0V	—	—	—	—	—	-2	
I _{CCA} + I _{CCB}	Supply Current	V _I = V _{CCI} or GND I _O = 0	1.2V to 3.6V	1.2V to 3.6V	—	—	—	—	—	20	μA
C _I	Input Capacitance	DIR	V _I = V _{CC} (A) or GND	3.3V	3.3V	—	2.5	—	—	—	pF
C _{IO}	Input/Output Capacitance	A or B pin	V _I = V _{CC} (A)/(B) or GND	3.3V	3.3V	—	6.0	—	—	—	pF

Notes: 9. V_{CCO} is the V_{CC} associated with the output port.
10. V_{CCI} is the V_{CC} associated with the input port.

Package Characteristics ($V_{CC} = 3.3V$, $T_A = +25^{\circ}C$, unless otherwise specified.)

Symbol	Parameter	Package	Test Conditions	Min	Typ	Max	Unit
θ_{JA}	Thermal Resistance Junction-to-Ambient	SOT26	(Note 11)	—	166	—	$^{\circ}C/W$
		SOT363		—	371	—	
		X2-DFN0910-6		—	530	—	
		X2-DFN1410-6		—	430	—	
		X2-DFN1409-6		—	450	—	
		X1-DFN1010-6		—	510	—	
θ_{JC}	Thermal Resistance Junction-to-Case	SOT26	(Note 11)	—	46	—	$^{\circ}C/W$
		SOT363		—	143	—	
		X2-DFN0910-6		—	260	—	
		X2-DFN1410-6		—	190	—	
		X2-DFN1409-6		—	200	—	
		X1-DFN1010-6		—	250	—	

Note: 11. Test condition for all packages: Device mounted on FR-4 substrate PC board, 2oz copper with minimum recommended pad layout.

Switching Characteristics

$V_{CC} (A) = 1.2V$, $T_A = -40^{\circ}C$ to $+85^{\circ}C$, See Figure 1

Parameter	From (Input)	To (Output)	$V_{CC}(B) = 1.2V$	$V_{CC}(B) = 1.5V \pm 0.1$	$V_{CC}(B) = 1.8V \pm 0.15V$	$V_{CC}(B) = 2.5V \pm 0.2V$	$V_{CC}(B) = 3.3V \pm 0.3V$	Unit
			TYP	TYP	TYP	TYP	TYP	
t_{pLH}	A	B	3.3	2.7	2.4	2.3	2.4	ns
t_{pHL}			3.3	2.7	2.4	2.3	2.4	
t_{pLH}	B	A	3.3	3.1	2.9	2.8	2.7	ns
t_{pHL}			3.3	3.1	2.9	2.8	2.7	
t_{pHZ}	DIR	A	5.1	5.2	5.3	5.2	3.7	ns
t_{pLZ}			5.1	5.2	5.3	5.2	3.7	
t_{pHZ}	DIR	B	5.3	4.3	4.0	3.3	3.7	ns
t_{pLZ}			5.3	4.3	4.0	3.3	3.7	
t_{pZH}^*	DIR	A	8.6	7.3	6.8	6.1	6.4	ns
t_{pZL}^*			8.6	7.3	6.8	6.1	6.4	
t_{pZH}^*	DIR	B	8.3	7.8	7.7	7.5	5.8	ns
t_{pZL}^*			8.3	7.8	7.7	7.5	5.8	

*Enable times are calculated vales see table at end of switching characteristics.

$V_{CC} (A) = 1.5V \pm 0.1V$, $T_A = -40^{\circ}C$ to $+85^{\circ}C$, See Figure 1

Parameter	From (Input)	To (Output)	$V_{CC}(B) = 1.2V$	$V_{CC}(B) = 1.5V \pm 0.1$		$V_{CC}(B) = 1.8V \pm 0.15V$		$V_{CC}(B) = 2.5V \pm 0.2V$		$V_{CC}(B) = 3.3V \pm 0.3V$		Unit
			TYP	Min	Max	Min	Max	Min	Max	Min	Max	
t_{pLH}	A	B	2.9	0.7	5.6	0.6	5.2	0.5	4.2	0.5	3.8	ns
t_{pHL}			2.9	0.7	5.6	0.6	5.2	0.5	4.2	0.5	3.8	
t_{pLH}	B	A	2.6	0.6	5.5	0.4	5.3	0.3	4.9	0.3	4.8	ns
t_{pHL}			2.6	0.6	5.5	0.4	5.3	0.3	4.9	0.3	4.8	
t_{pHZ}	DIR	A	3.8	1.6	6.7	1.5	6.8	0.3	6.9	0.9	6.9	ns
t_{pLZ}			3.8	1.6	6.7	1.5	6.8	0.3	6.9	0.9	6.9	
t_{pHZ}	DIR	B	5.1	1.8	8.1	1.6	7.1	1.1	4.7	1.4	4.5	ns
t_{pLZ}			5.1	1.8	8.1	1.6	7.1	1.1	4.7	1.4	4.5	
t_{pZH}^*	DIR	A	7.7	—	13.6	—	12.4	—	9.6	—	9.3	ns
t_{pZL}^*			7.7	—	13.6	—	12.4	—	9.6	—	9.3	
t_{pZH}^*	DIR	B	6.7	—	12.3	—	12	—	11.1	—	10.7	ns
t_{pZL}^*			6.7	—	12.3	—	12	—	11.1	—	10.7	

*Enable times are calculated vales see table at end of switching characteristics.

Switching Characteristics (continued)

 $V_{CC}(A) = 1.8V \pm 0.15V$, $T_A = -40^\circ C$ to $+85^\circ C$, See Figure 1

Parameter	From (Input)	To (Output)	$V_{CC}(B) = 1.2V$	$V_{CC}(B) = 1.5V \pm 0.1$		$V_{CC}(B) = 1.8V \pm 0.15V$		$V_{CC}(B) = 2.5V \pm 0.2V$		$V_{CC}(B) = 3.3V \pm 0.3V$		Unit
			TYP	Min	Max	Min	Max	Min	Max	Min	Max	
t_{pLH}	A	B	2.7	0.6	5.3	0.5	5.0	0.4	3.9	0.4	3.4	ns
t_{pHL}			2.7	0.6	5.3	0.5	5.0	0.4	3.9	0.4	3.4	
t_{pLH}	B	A	2.3	0.5	5.2	0.4	5.0	0.3	4.6	0.2	4.4	ns
t_{pHL}			2.3	0.5	5.2	0.4	5.0	0.3	4.6	0.2	4.4	
t_{pHZ}	DIR	A	3.8	1.6	5.9	1.6	5.9	1.6	5.9	0.5	6.0	ns
t_{pLZ}			3.8	1.6	5.9	1.6	5.9	1.6	5.9	0.5	6.0	
t_{pHZ}	DIR	B	5.0	1.8	7.7	1.4	6.8	1.0	4.4	1.4	5.3	ns
t_{pLZ}			5.0	1.8	7.7	1.4	6.8	1.0	4.4	1.4	5.3	
t_{pZH}^*	DIR	A	7.3	—	12.9	—	11.8	—	9.0	—	8.7	ns
t_{pZL}^*			7.3	—	12.9	—	11.8	—	9.0	—	8.7	
t_{pZH}^*	DIR	B	6.5	—	11.2	—	10.9	—	9.8	—	9.4	ns
t_{pZL}^*			6.5	—	11.2	—	10.9	—	9.8	—	9.4	

*Enable times are calculated vales see table at end of switching characteristics.

 $V_{CC}(A) = 2.5V \pm 0.2V$, $T_A = -40^\circ C$ to $+85^\circ C$, See Figure 1

Parameter	From (Input)	To (Output)	$V_{CC}(B) = 1.2V$	$V_{CC}(B) = 1.5V \pm 0.1$		$V_{CC}(B) = 1.8V \pm 0.15V$		$V_{CC}(B) = 2.5V \pm 0.2V$		$V_{CC}(B) = 3.3V \pm 0.3V$		Unit
			TYP	Min	Max	Min	Max	Min	Max	Min	Max	
t_{pLH}	A	B	2.6	0.5	4.9	0.4	4.6	0.3	3.4	0.3	3.0	ns
t_{pHL}			2.6	0.5	4.9	0.4	4.6	0.3	3.4	0.3	3.0	
t_{pLH}	B	A	2.2	0.4	4.2	0.3	3.8	0.2	3.4	0.2	3.3	ns
t_{pHL}			2.2	0.4	4.2	0.3	3.8	0.2	3.4	0.2	3.3	
t_{pHZ}	DIR	A	2.8	0.3	3.8	0.8	3.8	0.4	3.8	0.5	3.8	ns
t_{pLZ}			2.8	0.3	3.8	0.8	3.8	0.4	3.8	0.5	3.8	
t_{pHZ}	DIR	B	4.9	2.0	7.6	1.5	6.5	0.6	4.1	1.0	4.0	ns
t_{pLZ}			4.9	2.0	7.6	1.5	6.5	0.6	4.1	1.0	4.0	
t_{pZH}^*	DIR	A	7.1	—	11.8	—	10.3	—	7.5	—	7.3	ns
t_{pZL}^*			7.1	—	11.8	—	10.3	—	7.5	—	7.3	
t_{pZH}^*	DIR	B	5.4	—	8.6	—	8.1	—	7.0	—	6.6	ns
t_{pZL}^*			5.4	—	8.6	—	8.1	—	7.0	—	6.6	

*Enable times are calculated vales see table at end of switching characteristics.

 $V_{CC}(A) = 3.3V \pm 0.3V$, $T_A = -40^\circ C$ to $+85^\circ C$, See Figure 1

Parameter	From (Input)	To (Output)	$V_{CC}(B) = 1.2V$	$V_{CC}(B) = 1.5V \pm 0.1$		$V_{CC}(B) = 1.8V \pm 0.15V$		$V_{CC}(B) = 2.5V \pm 0.2V$		$V_{CC}(B) = 3.3V \pm 0.3V$		Unit
			TYP	Min	Max	Min	Max	Min	Max	Min	Max	
t_{pLH}	A	B	2.6	0.4	4.7	0.3	4.4	0.2	3.3	0.2	2.8	ns
t_{pHL}			2.6	0.4	4.7	0.3	4.4	0.2	3.3	0.2	2.8	
t_{pLH}	B	A	2.2	0.4	3.8	0.3	3.4	0.2	3	0.1	2.8	ns
t_{pHL}			2.2	0.4	3.8	0.3	3.4	0.2	3	0.1	2.8	
t_{pHZ}	DIR	A	3.1	1.3	4.3	1.3	4.3	1.3	4.3	1.3	4.3	ns
t_{pLZ}			3.1	1.3	4.3	1.3	4.3	1.3	4.3	1.3	4.3	
t_{pHZ}	DIR	B	4	0.7	7.4	0.6	6.5	0.7	4	1.5	4.9	ns
t_{pLZ}			4	0.7	7.4	0.6	6.5	0.7	4	1.5	4.9	
t_{pZH}^*	DIR	A	6.2	—	11.2	—	9.9	—	7	—	6.7	ns
t_{pZL}^*			6.2	—	11.2	—	9.9	—	7	—	6.7	
t_{pZH}^*	DIR	B	5.7	—	8.9	—	8.5	—	7.2	—	6.8	ns
t_{pZL}^*			5.7	—	8.9	—	8.5	—	7.2	—	6.8	

*Enable times are calculated vales see table at end of switching characteristics.

Enable Time Calculations

Enable times can be calculated as follows:

- $t_{pZH} \text{ (DIR to A)} = t_{pLZ} \text{ (DIR to B)} + t_{pLH} \text{ (B to A)}$
- $t_{pZL} \text{ (DIR to A)} = t_{pHZ} \text{ (DIR to B)} + t_{pHL} \text{ (B to A)}$
- $t_{pZH} \text{ (DIR to B)} = t_{pLZ} \text{ (DIR to A)} + t_{pLH} \text{ (A to B)}$
- $t_{pZL} \text{ (DIR to B)} = t_{pHZ} \text{ (DIR to A)} + t_{pHL} \text{ (A to B)}$

These times represent the length of time from a direction change plus the propagation time through the part.

A new input signal must not be applied until the new input pin has been disabled.

Operating Characteristics (T_A = +25°C, unless otherwise specified.)

Parameter Power Dissipation Capacitance		Test Conditions	V _{CC} (A) = V _{CC} (B) = 1.8V	V _{CC} (A) = V _{CC} (B) = 2.5V	V _{CC} (A) = V _{CC} (B) = 3.3V	V _{CC} (A) = V _{CC} (B) = 5V	Unit
			Typ	Typ	Typ	Typ	
C _{pd} (A)	A- Input, B- Output	C _L = 0 pF f = 10 MHz tr = tf = 1 ns	3	4	4	4	pF
	B- Input, A- Output		18	19	20	21	
C _{pd} (B)	A- Input, B- Output	C _L = 0 pF f = 10 MHz tr = tf = 1 ns	18	19	20	21	pF
	B- Input, A- Output		3	4	4	4	

Parameter Measurement Information

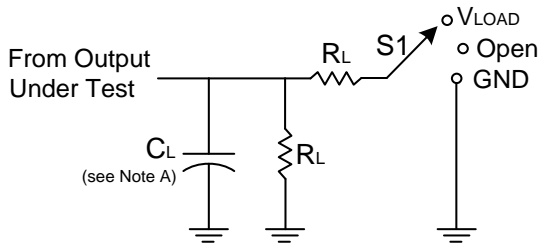

TEST	S1
t_{PLH}/t_{PHL}	Open
t_{PLZ}/t_{PZL}	Vload
t_{PHZ}/t_{PZH}	GND

V_{CC}	Inputs		V_M	V_{LOAD}	C_L	R_L	V_{Δ}
	V_I	t_r/t_f					
1.2V	V_{CCI}	$\leq 2ns$	$V_{CCO}/2$	$2 \times V_{CCO}$	15pF	2K Ω	0.15V
1.8V \pm 0.15V	V_{CCI}	$\leq 2ns$	$V_{CCO}/2$	$2 \times V_{CCO}$	15pF	2K Ω	0.15V
2.5V \pm 0.2V	V_{CCI}	$\leq 2ns$	$V_{CCO}/2$	$2 \times V_{CCO}$	15pF	2K Ω	0.15V
3.3V \pm 0.3V	V_{CCI}	$\leq 2.5ns$	$V_{CCO}/2$	$2 \times V_{CCO}$	15pF	2K Ω	0.3V

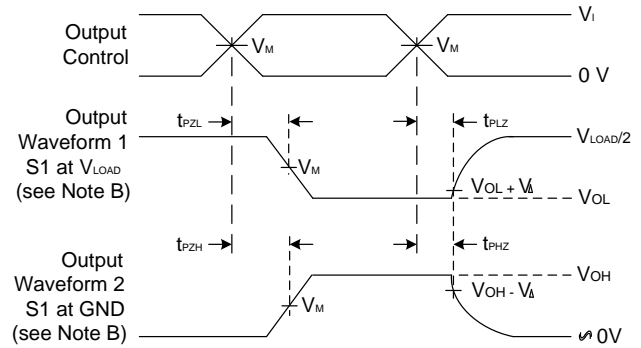
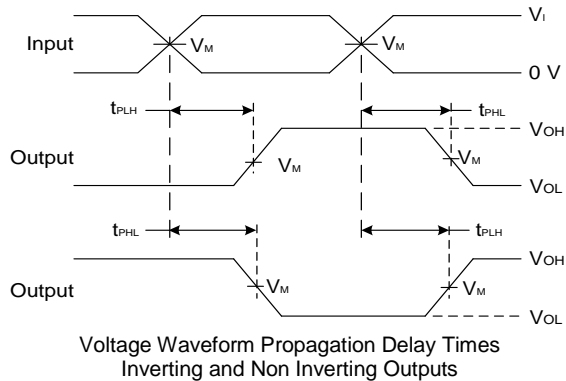
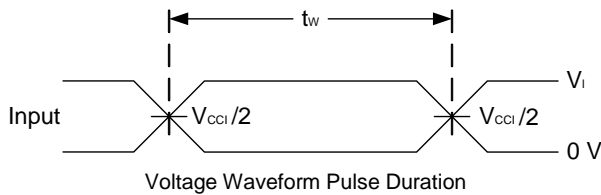
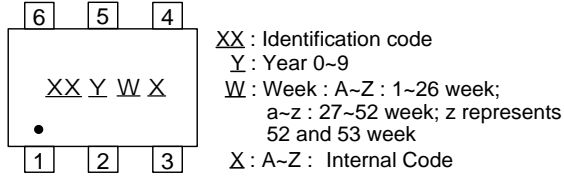

Figure 1. Load Circuit and Voltage Waveforms

- Notes:
- A. Includes test lead and test apparatus capacitance.
 - B. Waveform 1 is for an output with input set up as a low and device coming out or into 3-state via DIR control. Waveform 2 is for an output with input set up as a high and device coming out or into 3-state via DIR control.
 - C. All pulses are supplied at pulse repetition rate ≤ 10 MHz.
 - D. t_{PLZ} and t_{PHZ} are the same as t_{dis} .
 - E. t_{PZL} and t_{PZH} are the same as t_{EN} .
 - F. t_{PLH} and t_{PHL} are the same as t_{PD} .
 - G. V_{CCI} is the V_{CC} associated with the input.
 - F. V_{CCO} is the V_{CC} associated with the output.

Marking Information

(1) SOT363, SOT563



Part Number	Package	Identification Code
74AVC1T45W6-7	SOT26	7A
74AVC1T45DW-7	SOT363	7B

(2) X2-DFN1010-6, X2-DFN1410-6, and X2-DFN1409-6

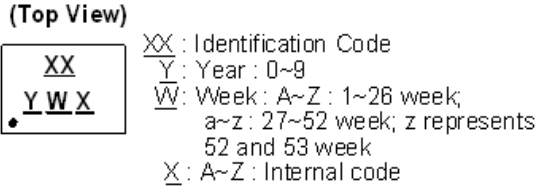

Part Number	Package	Identification Code
74AVC1T45FW3-7	X2-DFN0910-6	7A
74AVC1T45FW5-7	X1-DFN1010-6	7X
74AVC1T45FX4-7	X2-DFN1409-6	7B
74AVC1T45FZ4-7	X2-DFN1410-6	7C

Package Outline Dimensions (All dimensions in mm.)

Please see <http://www.diodes.com/package-outlines.html> for the latest version.

SOT26 (SC74R)

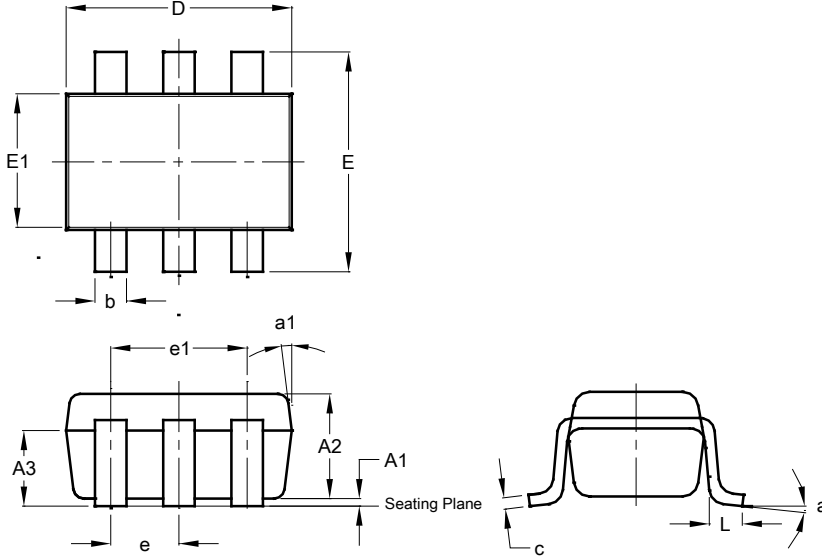

SOT26 (SC74R)			
Dim	Min	Max	Typ
A1	0.013	0.10	0.05
A2	1.00	1.30	1.10
A3	0.70	0.80	0.75
b	0.35	0.50	0.38
c	0.10	0.20	0.15
D	2.90	3.10	3.00
e	-	-	0.95
e1	-	-	1.90
E	2.70	3.00	2.80
E1	1.50	1.70	1.60
L	0.35	0.55	0.40
a	-	-	8°
a1	-	-	7°
All Dimensions in mm			

Suggested Pad Layout

Please see <http://www.diodes.com/package-outlines.html> for the latest version.

SOT26 (SC74R)

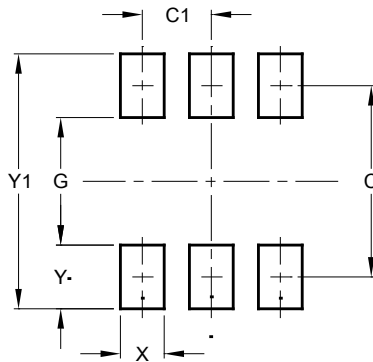

Dimensions	Value (in mm)
C	2.40
C1	0.95
G	1.60
X	0.55
Y	0.80
Y1	3.20

Package Outline Dimensions (All dimensions in mm.)

Please see <http://www.diodes.com/package-outlines.html> for the latest version.

SOT363

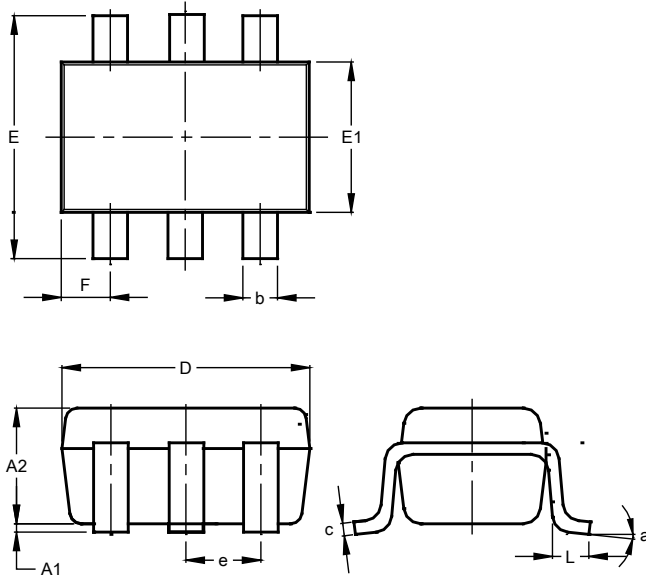

SOT363			
Dim	Min	Max	Typ
A1	0.00	0.10	0.05
A2	0.90	1.00	0.95
b	0.10	0.30	0.25
c	0.10	0.22	0.11
D	1.80	2.20	2.15
E	2.00	2.20	2.10
E1	1.15	1.35	1.30
e	0.650 BSC		
F	0.40	0.45	0.425
L	0.25	0.40	0.30
a	0°	8°	--
All Dimensions in mm			

Suggested Pad Layout

Please see <http://www.diodes.com/package-outlines.html> for the latest version.

SOT363

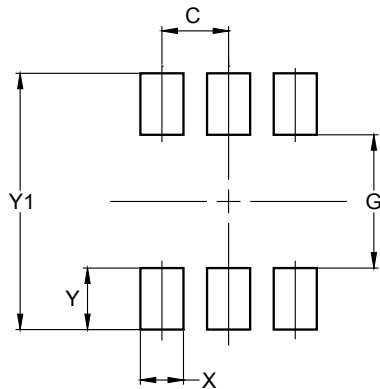

Dimensions	Value (in mm)
C	0.650
G	1.300
X	0.420
Y	0.600
Y1	2.500

Package Outline Dimensions (All dimensions in mm.)

Please see <http://www.diodes.com/package-outlines.html> for the latest version.

X1-DFN1010-6 (Type B)

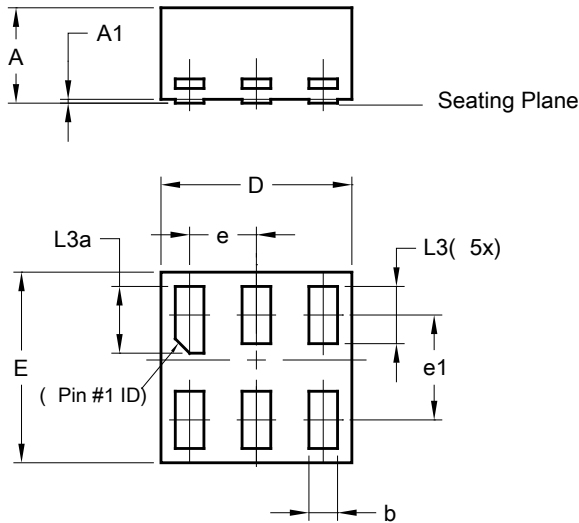

X1-DFN1010-6 (Type B)			
Dim	Min	Max	Typ
A	-	0.50	0.39
A1	-	0.04	-
b	0.12	0.20	0.15
D	0.95	1.050	1.00
E	0.95	1.050	1.00
e	0.35 BSC		
e1	0.55 BSC		
L3	0.27	0.30	0.30
L3a	0.32	0.40	0.35
All Dimensions in mm			

Suggested Pad Layout

Please see <http://www.diodes.com/package-outlines.html> for the latest version.

X1-DFN1010-6 (Type B)

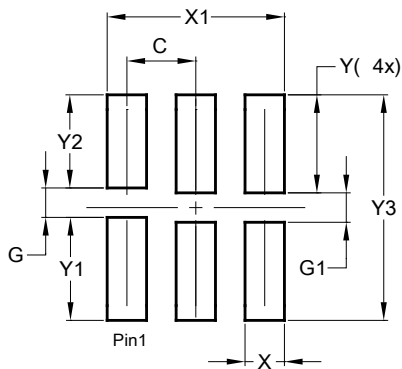

Dimensions	Value (in mm)
C	0.350
G	0.150
G1	0.150
X	0.200
X1	0.900
Y	0.500
Y1	0.525
Y2	0.475
Y3	1.150

Package Outline Dimensions (All dimensions in mm.)

Please see <http://www.diodes.com/package-outlines.html> for the latest version.

X2-DFN0910-6

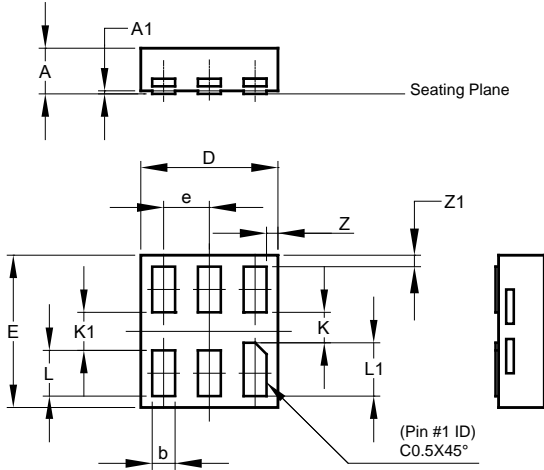

X2-DFN0910-6			
Dim	Min	Max	Typ
A	-	0.35	0.30
A1	0	0.03	0.02
b	0.10	0.20	0.15
D	0.85	0.95	0.90
E	0.95	1.05	1.00
e	-	-	0.30
K	0.20	-	-
K1	0.25	-	-
L	0.25	0.35	0.30
L1	0.30	0.40	0.35
Z	-	-	0.075
Z1	-	-	0.075
All Dimensions in mm			

Suggested Pad Layout

Please see <http://www.diodes.com/package-outlines.html> for the latest version.

X2-DFN0910-6

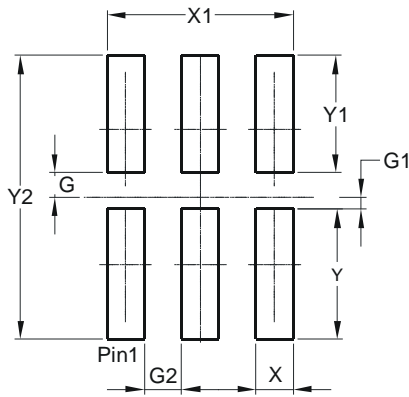

Dimensions	Value (in mm)
G	0.100
G1	0.050
G2	0.150
X	0.150
X1	0.750
Y	0.525
Y1	0.475
Y2	1.150

Package Outline Dimensions (All dimensions in mm.)

Please see <http://www.diodes.com/package-outlines.html> for the latest version.

X2-DFN1409-6

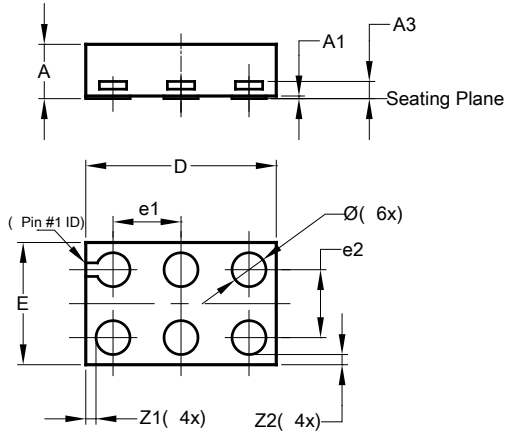

X2-DFN1409-6			
Dim	Min	Max	Typ
A	-	0.40	0.39
A1	0	0.05	0.02
A3	-	-	0.13
Ø	0.20	0.30	0.25
D	1.35	1.45	1.40
E	0.85	0.95	0.90
e1	-	-	0.50
e2	-	-	0.50
Z1	-	-	0.075
Z2	-	-	0.075
All Dimensions in mm			

Suggested Pad Layout

Please see <http://www.diodes.com/package-outlines.html> for the latest version.

X2-DFN1409-6

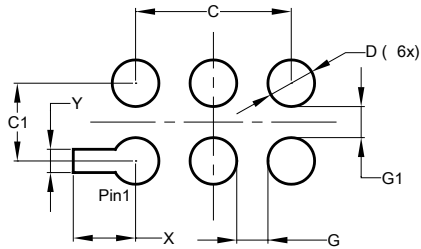

Dimensions	Value (in mm)
C	1.000
C1	0.500
D	0.300
G	0.200
G1	0.200
X	0.400
Y	0.150

Package Outline Dimensions (All dimensions in mm.)

Please see <http://www.diodes.com/package-outlines.html> for the latest version.

X2-DFN1410-6

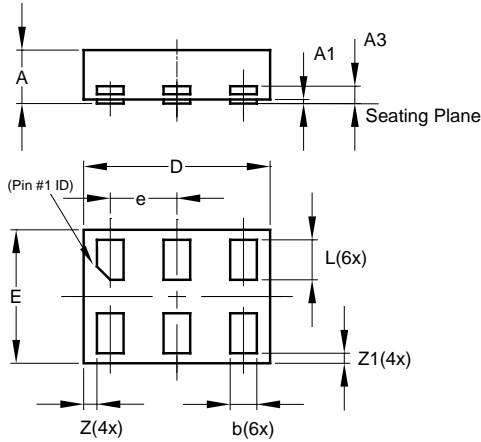

X2-DFN1410-6			
Dim	Min	Max	Typ
A	—	0.40	0.39
A1	0.00	0.05	0.02
A3	—	—	0.13
b	0.15	0.25	0.20
D	1.35	1.45	1.40
E	0.95	1.05	1.00
e	—	—	0.50
L	0.25	0.35	0.30
Z	—	—	0.10
Z1	0.045	0.105	0.075
All Dimensions in mm			

Suggested Pad Layout

Please see <http://www.diodes.com/package-outlines.html> for the latest version.

X2-DFN1410-6

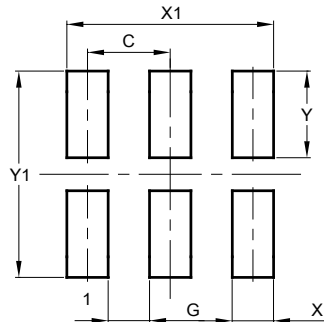

Dimension s	Value (in mm)
C	0.500
G	0.250
X	0.250
X1	1.250
Y	0.525
Y1	1.250

IMPORTANT NOTICE

DIODES INCORPORATED MAKES NO WARRANTY OF ANY KIND, EXPRESS OR IMPLIED, WITH REGARDS TO THIS DOCUMENT, INCLUDING, BUT NOT LIMITED TO, THE IMPLIED WARRANTIES OF MERCHANTABILITY AND FITNESS FOR A PARTICULAR PURPOSE (AND THEIR EQUIVALENTS UNDER THE LAWS OF ANY JURISDICTION).

Diodes Incorporated and its subsidiaries reserve the right to make modifications, enhancements, improvements, corrections or other changes without further notice to this document and any product described herein. Diodes Incorporated does not assume any liability arising out of the application or use of this document or any product described herein; neither does Diodes Incorporated convey any license under its patent or trademark rights, nor the rights of others. Any Customer or user of this document or products described herein in such applications shall assume all risks of such use and will agree to hold Diodes Incorporated and all the companies whose products are represented on Diodes Incorporated website, harmless against all damages.

Diodes Incorporated does not warrant or accept any liability whatsoever in respect of any products purchased through unauthorized sales channel. Should Customers purchase or use Diodes Incorporated products for any unintended or unauthorized application, Customers shall indemnify and hold Diodes Incorporated and its representatives harmless against all claims, damages, expenses, and attorney fees arising out of, directly or indirectly, any claim of personal injury or death associated with such unintended or unauthorized application.

Products described herein may be covered by one or more United States, international or foreign patents pending. Product names and markings noted herein may also be covered by one or more United States, international or foreign trademarks.

This document is written in English but may be translated into multiple languages for reference. Only the English version of this document is the final and determinative format released by Diodes Incorporated.

LIFE SUPPORT

Diodes Incorporated products are specifically not authorized for use as critical components in life support devices or systems without the express written approval of the Chief Executive Officer of Diodes Incorporated. As used herein:

A. Life support devices or systems are devices or systems which:

1. are intended to implant into the body, or
2. support or sustain life and whose failure to perform when properly used in accordance with instructions for use provided in the labeling can be reasonably expected to result in significant injury to the user.

B. A critical component is any component in a life support device or system whose failure to perform can be reasonably expected to cause the failure of the life support device or to affect its safety or effectiveness.

Customers represent that they have all necessary expertise in the safety and regulatory ramifications of their life support devices or systems, and acknowledge and agree that they are solely responsible for all legal, regulatory and safety-related requirements concerning their products and any use of Diodes Incorporated products in such safety-critical, life support devices or systems, notwithstanding any devices- or systems-related information or support that may be provided by Diodes Incorporated. Further, Customers must fully indemnify Diodes Incorporated and its representatives against any damages arising out of the use of Diodes Incorporated products in such safety-critical, life support devices or systems.

Copyright © 2018, Diodes Incorporated

www.diodes.com



Компания «ЭлектроПласт» предлагает заключение долгосрочных отношений при поставках импортных электронных компонентов на взаимовыгодных условиях!

Наши преимущества:

- Оперативные поставки широкого спектра электронных компонентов отечественного и импортного производства напрямую от производителей и с крупнейших мировых складов;
- Поставка более 17-ти миллионов наименований электронных компонентов;
- Поставка сложных, дефицитных, либо снятых с производства позиций;
- Оперативные сроки поставки под заказ (от 5 рабочих дней);
- Экспресс доставка в любую точку России;
- Техническая поддержка проекта, помощь в подборе аналогов, поставка прототипов;
- Система менеджмента качества сертифицирована по Международному стандарту ISO 9001;
- Лицензия ФСБ на осуществление работ с использованием сведений, составляющих государственную тайну;
- Поставка специализированных компонентов (Xilinx, Altera, Analog Devices, Intersil, Interpoint, Microsemi, Aeroflex, Peregrine, Syfer, Eurofarad, Texas Instrument, Miteq, Cobham, E2V, MA-COM, Hittite, Mini-Circuits, General Dynamics и др.);

Помимо этого, одним из направлений компании «ЭлектроПласт» является направление «Источники питания». Мы предлагаем Вам помощь Конструкторского отдела:

- Подбор оптимального решения, техническое обоснование при выборе компонента;
- Подбор аналогов;
- Консультации по применению компонента;
- Поставка образцов и прототипов;
- Техническая поддержка проекта;
- Защита от снятия компонента с производства.



Как с нами связаться

Телефон: 8 (812) 309 58 32 (многоканальный)

Факс: 8 (812) 320-02-42

Электронная почта: org@eplast1.ru

Адрес: 198099, г. Санкт-Петербург, ул. Калинина, дом 2, корпус 4, литера А.