

V3 83161 High release force 831611 Part number 83161118



- Nominal ratings 0.1 A to 20 A / 250 VAC
- Operating temperature up to +125 °C
- Conforming to EN 61058 and UL 1054
- Choice of actuators with 4 possible fixing positions

Part numbers

	Type	Function	Connections
83161118	High release force 831611	I (changeover)	W3

Specifications

Electrical characteristics

Rating nominal / 250 VAC (A)	16
Rating thermal / 250 VAC (A)	20

Mechanical characteristics

Maximum operating force (N)	3
Min. Release force (N)	1
Maximum total travel force (N)	4,5
Max. permitted overtravel force (N)	20
Maximum rest position (mm)	16,1
Operating position (mm)	14,7 ^{±0,4}
Maximum differential travel (mm)	0,35
Min. overtravel CRA (mm)	1,1
Ambient operating temperature (°C)	-20 → +125
Mechanical life for 2/3 CRA (operations)	10 ⁷
Contact gap (mm)	0,4
Weight (g)	5,6

Additional specifications

Components

Material

- Housings : polyamide or polyester
- Button : polyamide
- Contacts : AgNi

Levers

- Flat : stainless steel
- Roller : stainless steel, glass-filled polyamide roller
- Other polyamides

Approvals : NF

Principles

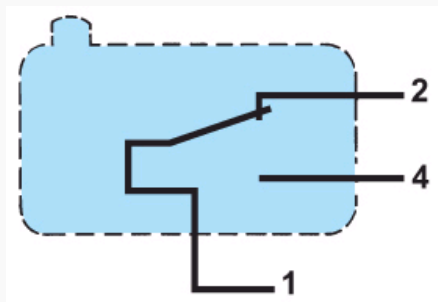

Dimensions (mm)

Product

83161

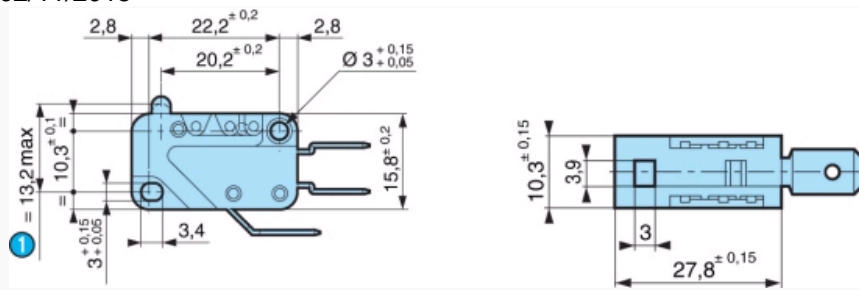

N°	Legend
1	OL

Dimensions (mm)

Connections

W2 solder

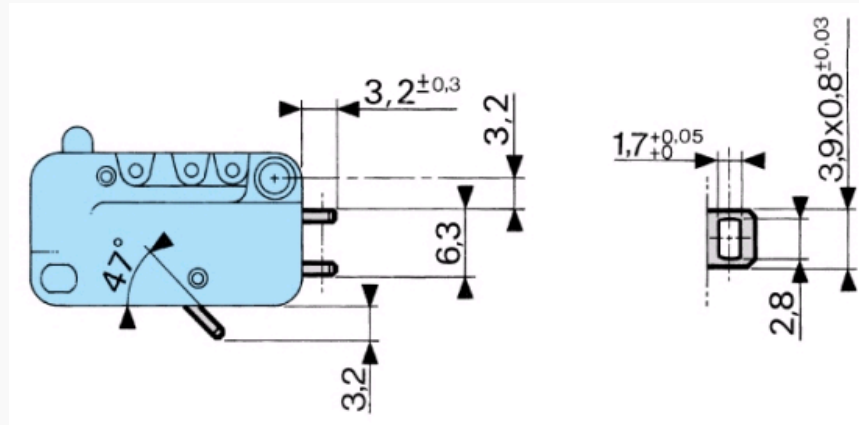

Dimensions (mm)

Connections

W3 for 6.35 mm clips (6.3 x 0.8)

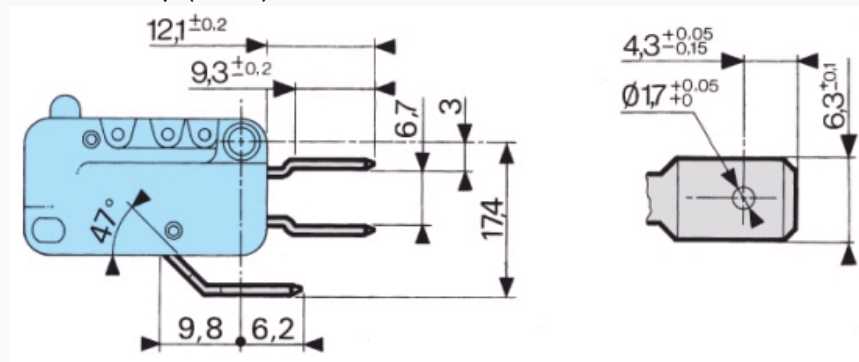

Dimensions (mm)

Connections

W3R5 for 6.35 mm clips (6.3 x 0.8)

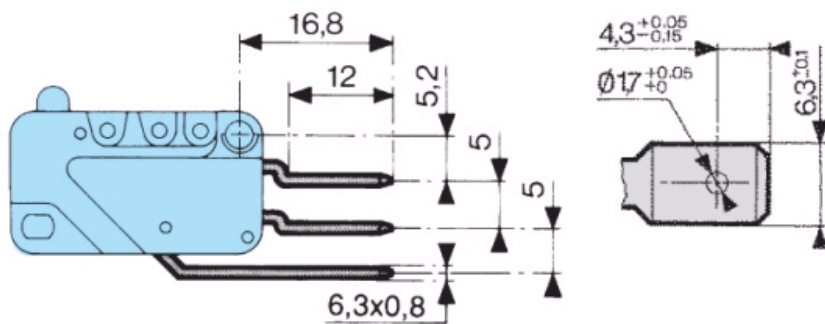

Dimensions (mm)

Connections

W5 screw

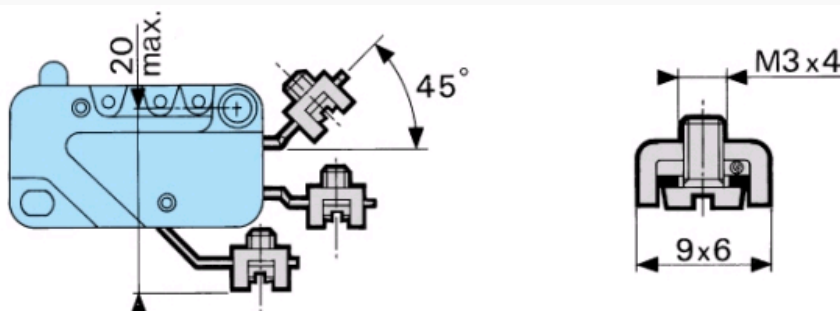

Dimensions (mm)

Connections

W6A5 for 4.8 mm clips (4.8 x 0.5)

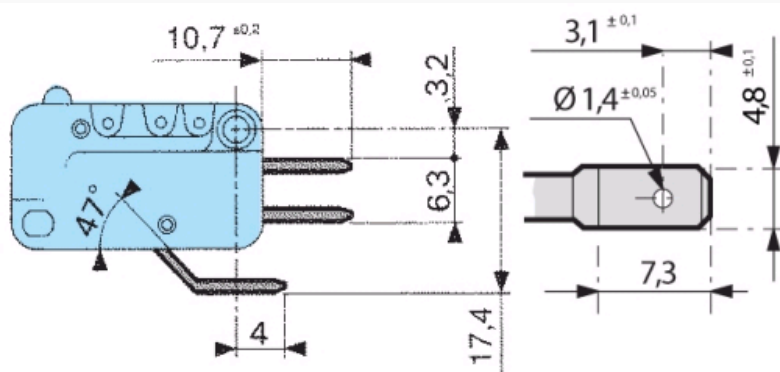

Dimensions (mm)

Connections

W6D8 for 4.8 mm clips (4.8 x 0.8)

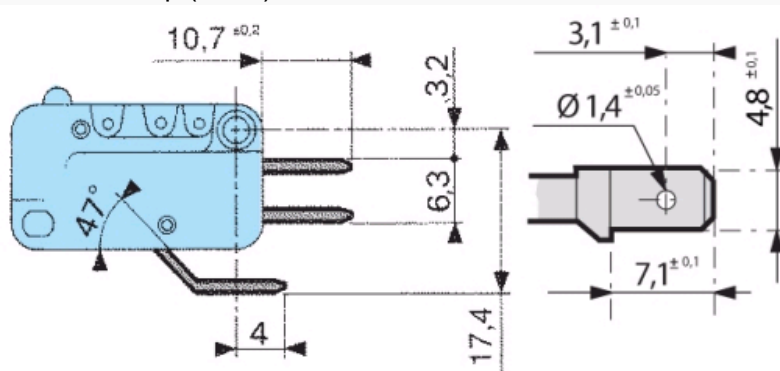

Dimensions (mm)

Connections

W7A5 for 2.8 mm clips (2.8 x 0.5)

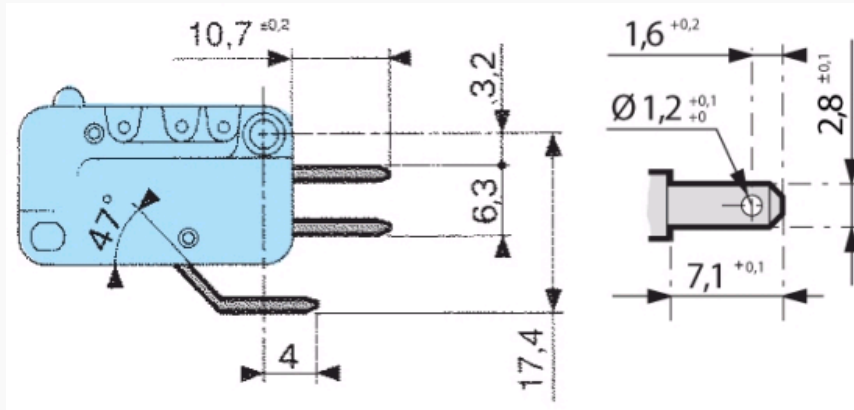

Dimensions (mm)

Connections

2W7A8 for 2.8 mm clips (2.8 x 0.8)

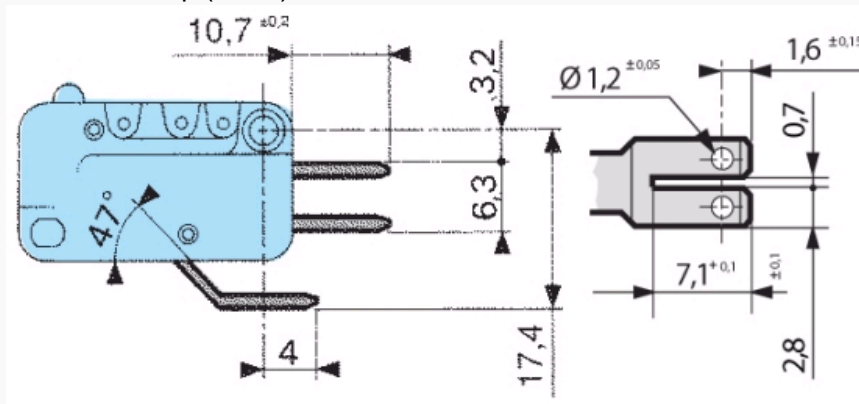

Dimensions (mm)

Actuator mounting positions

Levers

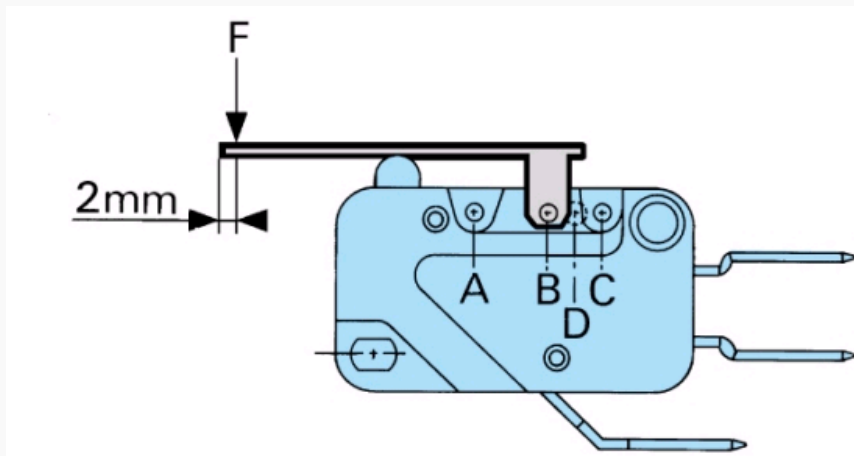

To calculate force Divide the switch force by the coefficient given in the table. To calculate travel Multiply the switch travel by the same coefficient. Example : 83 161 3 with lever 161 A - R 25.4 position A (coeff. 4) Operating force : $0.8 : 4 = 0.2$ N Pre-travel : $1.4 \times 4 = 5.6$ mm

Dimensions (mm)

Actuator mounting positions

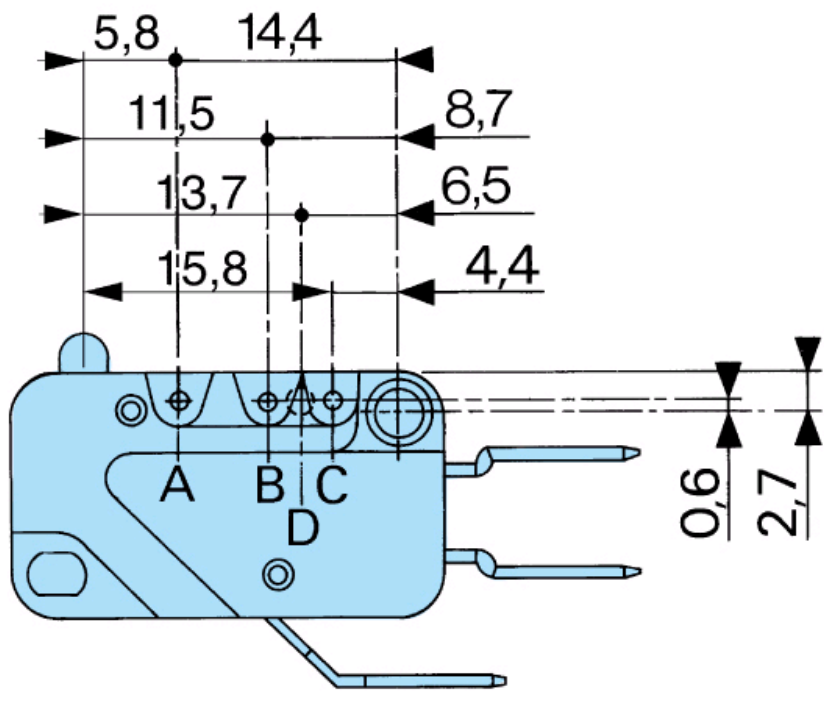

To calculate force Divide the switch force by the coefficient given in the table. To calculate travel Multiply the switch travel by the same coefficient. Example : 83 161 3 with lever 161 A - R 25.4 position A (coeff. 4) Operating force : $0.8 : 4 = 0.2$ N Pre-travel : $1.4 \times 4 = 5.6$ mm

Dimensions (mm)

Actuators

161 E

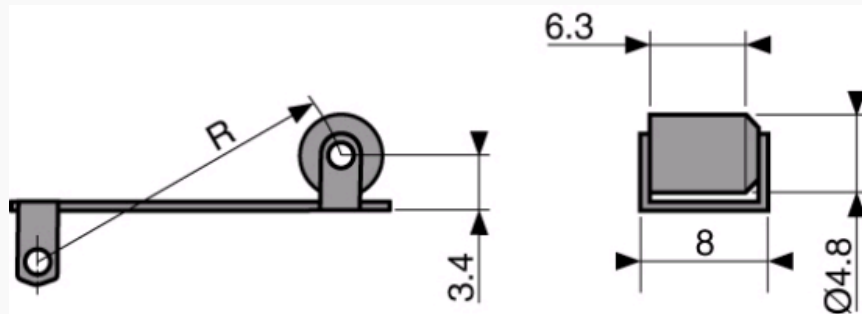

To calculate force Divide the switch force by the coefficient given in the table. To calculate travel Multiply the switch travel by the same coefficient. Example : 83 161 3 with lever 161 A - R 25.4 position A (coeff. 4) Operating force : $0.8 : 4 = 0.2$ N Pre-travel : $1.4 \times 4 = 5.6$ mm

Dimensions (mm)

Actuators

161 A

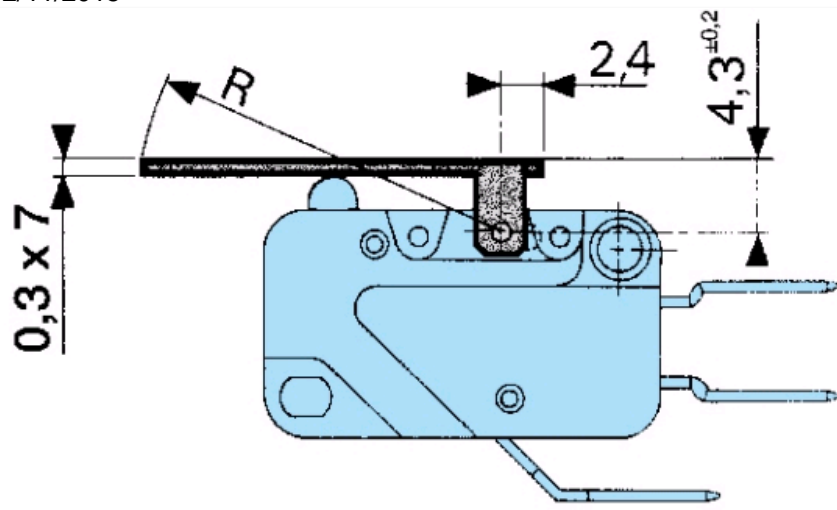

To calculate force Divide the switch force by the coefficient given in the table. To calculate travel Multiply the switch travel by the same coefficient. Example : 83 161 3 with lever 161 A - R 25.4 position A (coeff. 4) Operating force : $0.8 : 4 = 0.2$ N Pre-travel : $1.4 \times 4 = 5.6$ mm

Dimensions (mm)

Actuators

161 L

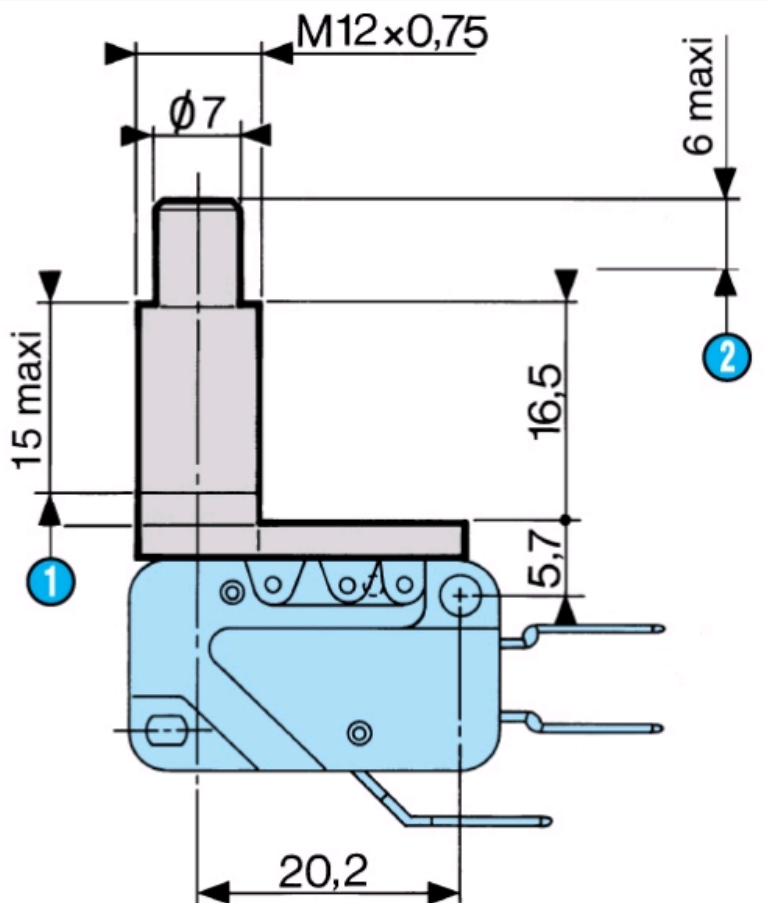

Nut thickness Max. torque 1.5 mm 5 Cm N 2 mm 7 Cm N 2.5 mm 10 Cm N

N°	Legend
①	Thread
②	Total travel

Dimensions (mm)

Actuators

161 V

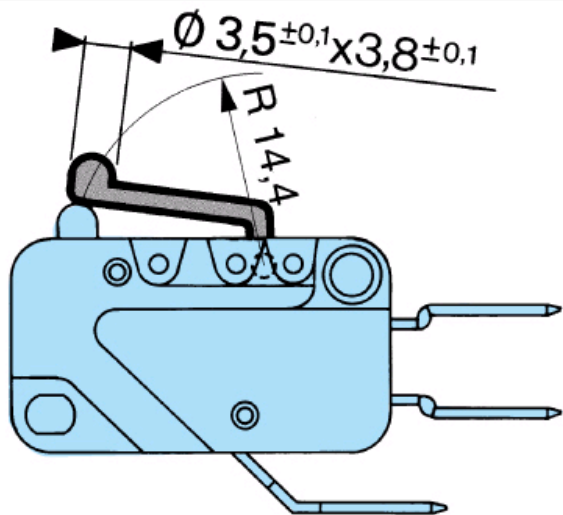

Nut thickness Max. torque 1.5 mm 5 Cm N 2 mm 7 Cm N 2.5 mm 10 Cm N

Dimensions (mm)

Actuators

161 F

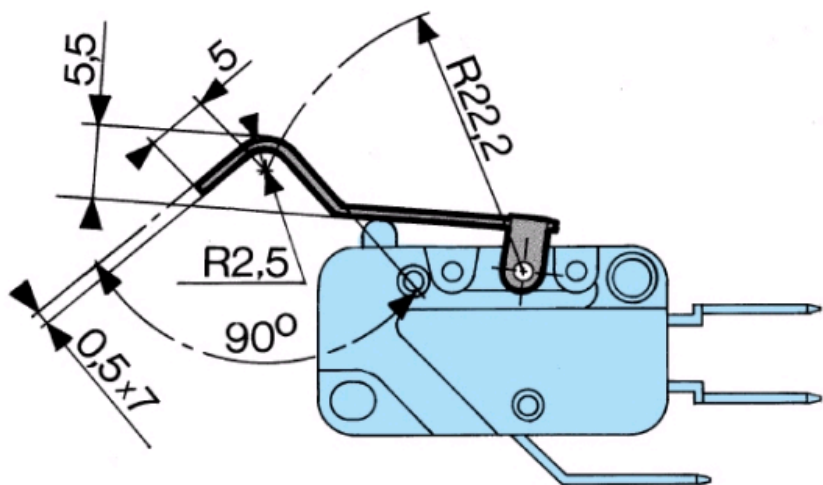

Nut thickness Max. torque 1.5 mm 5 Cm N 2 mm 7 Cm N 2.5 mm 10 Cm N

Dimensions (mm)

Actuators

161 G

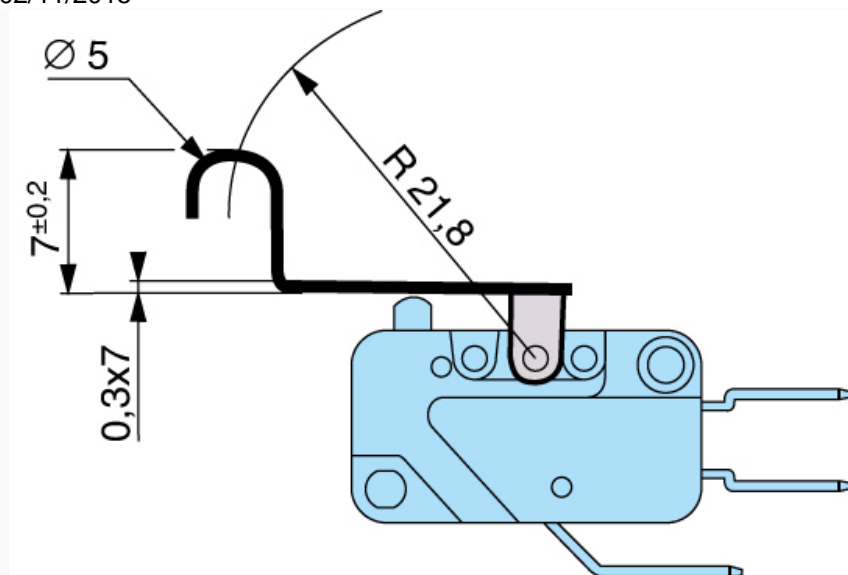

Nut thickness Max. torque 1.5 mm 5 Cm N 2 mm 7 Cm N 2.5 mm 10 Cm N

Dimensions (mm)

Mounting accessories

Nut 70602118

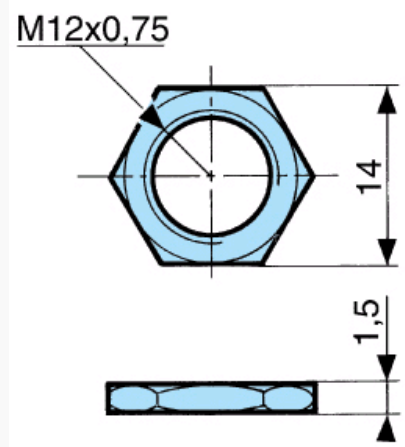

Nut thickness Max. torque 1.5 mm 5 Cm N 2 mm 7 Cm N 2.5 mm 10 Cm N

Dimensions (mm)

Mounting accessories

Housing 161 J for connections W3 R5

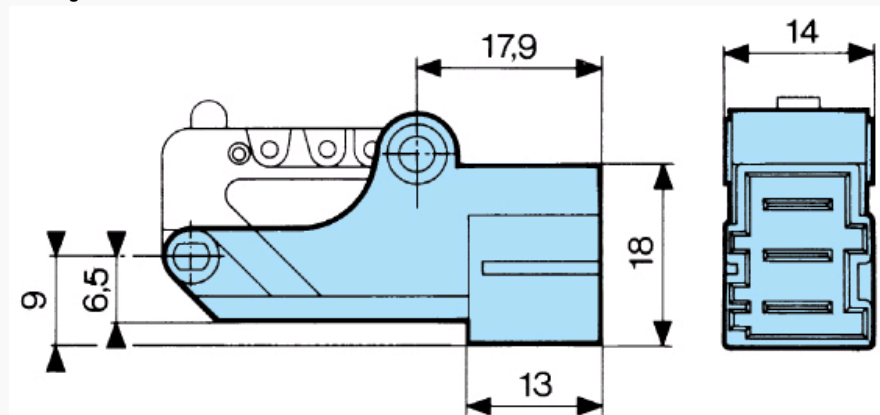

Nut thickness Max. torque 1.5 mm 5 Cm N 2 mm 7 Cm N 2.5 mm 10 Cm N

Curves

Operating curve for types 831611 / 831613 / 831616

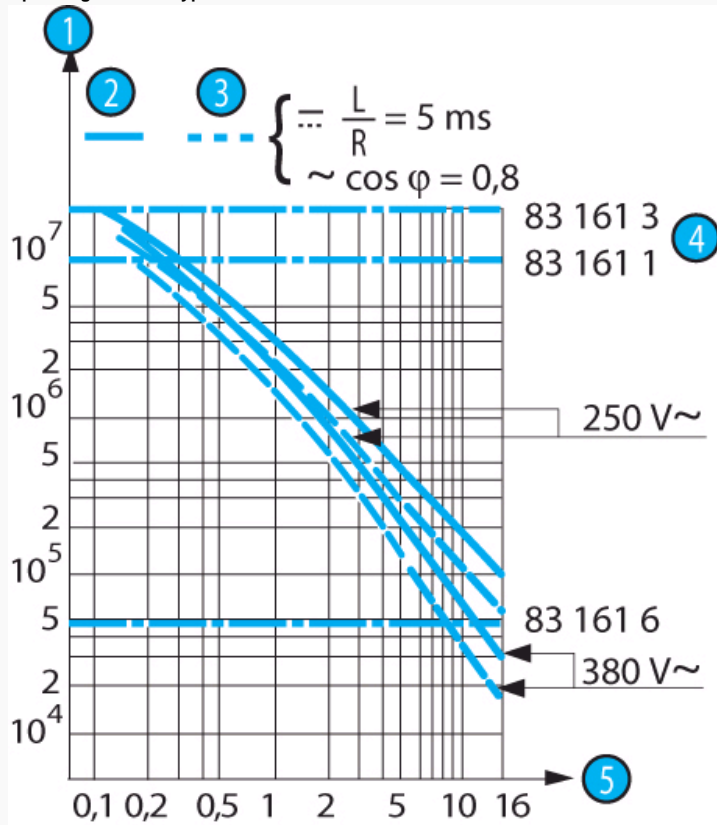

N°	Legend
1	Number of cycles
2	Resistive circuit
3	Inductive circuit
4	Mechanical life limit
5	Current in Amps

Connections

Actuators and fixing positions

Part numbers for standard actuators	79 215 740	70 507 524	79 215 742	70 507 529	70 507 528	
Actuators	Plain 161A R14,2	Plain 161A R25,4	Roller 161E R13,6	Roller 161E R24,1	Dummy roller 161F R22,2	
Fixing positions	A B	A B C	A B	A B C	A B	
Coefficient	2 1	4 2 1,5	2 1	4 2 1,5	3 1,8	
Tripping point (except 83 161 6)	15,2 st 15,2 st 15,2 st	15,2 st 15,2 st 15,2 st	20,5 st 20,5 st	20,5 st 20,5 st 20,5 st	20,4 st 20,4 st	
Tripping point 83 161 6	14,8 st 15 st	14,4 st 14,8 st 14,9 st	20,1 st 20,3 st	19,7 st 20,1 st 20,2 st	20,2 st 20,2 st	
Part numbers for standard actuators	79 218 651					
Actuators	Dummy roller 161G R21,8	**Telescopic plunger 161 L	Manual action	161V	Housing 161J	Nut for 161L Part no.: 70 602 118
Fixing positions	A B	D	D			
Coefficient	3 1,8	1	1			
Tripping point (except 83 161 6)	21,7 st 21,7 st	21,5 st	18,35 st			
Tripping point 83 161 6	21,5 st 21,5 st	21,5 st				

Except where otherwise indicated, plain and roller levers are supplied unmounted.
 For factory mounting, specify fixing position A, B or C.
 ** For 83 161 1, 83 161 2, 83 161 3, 83 161 6 mounted in factory (supplied without nut)

Other information

Mounting - Operation

See basic technical concepts

Product adaptations



- Special levers
- Special connections
- Specific fixing
- High operating temperature
- Special operating force
- Approvals : UL - cUL



Компания «ЭлектроПласт» предлагает заключение долгосрочных отношений при поставках импортных электронных компонентов на взаимовыгодных условиях!

Наши преимущества:

- Оперативные поставки широкого спектра электронных компонентов отечественного и импортного производства напрямую от производителей и с крупнейших мировых складов;
- Поставка более 17-ти миллионов наименований электронных компонентов;
- Поставка сложных, дефицитных, либо снятых с производства позиций;
- Оперативные сроки поставки под заказ (от 5 рабочих дней);
- Экспресс доставка в любую точку России;
- Техническая поддержка проекта, помощь в подборе аналогов, поставка прототипов;
- Система менеджмента качества сертифицирована по Международному стандарту ISO 9001;
- Лицензия ФСБ на осуществление работ с использованием сведений, составляющих государственную тайну;
- Поставка специализированных компонентов (Xilinx, Altera, Analog Devices, Intersil, Interpoint, Microsemi, Aeroflex, Peregrine, Syfer, Eurofarad, Texas Instrument, Miteq, Cobham, E2V, MA-COM, Hittite, Mini-Circuits, General Dynamics и др.);

Помимо этого, одним из направлений компании «ЭлектроПласт» является направление «Источники питания». Мы предлагаем Вам помощь Конструкторского отдела:

- Подбор оптимального решения, техническое обоснование при выборе компонента;
- Подбор аналогов;
- Консультации по применению компонента;
- Поставка образцов и прототипов;
- Техническая поддержка проекта;
- Защита от снятия компонента с производства.



Как с нами связаться

Телефон: 8 (812) 309 58 32 (многоканальный)

Факс: 8 (812) 320-02-42

Электронная почта: org@eplast1.ru

Адрес: 198099, г. Санкт-Петербург, ул. Калинина, дом 2, корпус 4, литера А.