



**Future Technology Devices International Ltd**

**TTL-232R-PCB**

**TTL to USB Serial Converter PCB**

**Datasheet**

**Document Reference No.: FT\_000065**

**Version 1.01**

**Issue Date: 2010-09-02**

**Future Technology Devices International Limited (FTDI)**

Unit 1, 2 Seaward Place, Glasgow G41 1HH, United Kingdom

Tel.: +44 (0) 141 429 2777 Fax: + 44 (0) 141 429 2758

E-Mail (Support): [support1@ftdichip.com](mailto:support1@ftdichip.com) Web: <http://www.ftdichip.com>

Neither the whole nor any part of the information contained in, or the product described in this manual, may be adapted or reproduced in any material or electronic form without the prior written consent of the copyright holder. This product and its documentation are supplied on an as-is basis and no warranty as to their suitability for any particular purpose is either made or implied. Future Technology Devices International Ltd will not accept any claim for damages howsoever arising as a result of use or failure of this product. Your statutory rights are not affected. This product or any variant of it is not intended for use in any medical appliance, device or system in which the failure of the product might reasonably be expected to result in personal injury. This document provides preliminary information that may be subject to change without notice. No freedom to use patents or other intellectual property rights is implied by the publication of this document. Future Technology Devices International Ltd, Unit 1, 2 Seaward Place, Centurion Business Park, Glasgow, G41 1HH, United Kingdom. Scotland Registered Number: SC136640

## 1 Description

The **TTL-232R-PCB** is a USB to TTL serial UART converter PCB incorporating FTDI's FT232RQ USB to Serial UART interface IC device which handles all the USB signalling and protocols. The PCB provides a fast, simple way to connect devices with a TTL level serial interface to USB.

Each TTL-232R\_PCB contains a small internal electronic circuit board, utilising the FT232R plus a USB type-A connector. The FT232R datasheet, DS\_FT232R, is available at <http://www.ftdichip.com>.

The PCB is RoHS compliant at TTL levels of + 5V or + 3.3V.

The PCB is USB powered and USB 2.0 full speed compatible. Each PCB supports a data transfer rate up to 3 Mbaud and supports the FTDIChip-ID™, with a unique USB serial number programmed into the FT232R. This feature can be used to create a security or password protected file transfer access using the PCB. Further information and examples on this feature are available at <http://www.ftdichip.com> under FTDIChip-ID Projects.

The TTL-232R\_PCB requires USB drivers, available free from <http://www.ftdichip.com>, which are used to make the FT232R on the PCB appear as a virtual COM port (VCP). This then allows the user to communicate with the USB interface via a standard PC serial emulation port (for example TTY). Another FTDI USB driver, the D2XX driver, can also be used with application software to directly access the FT232R on the PCB through a DLL. This is illustrated in the Figure 1.1.

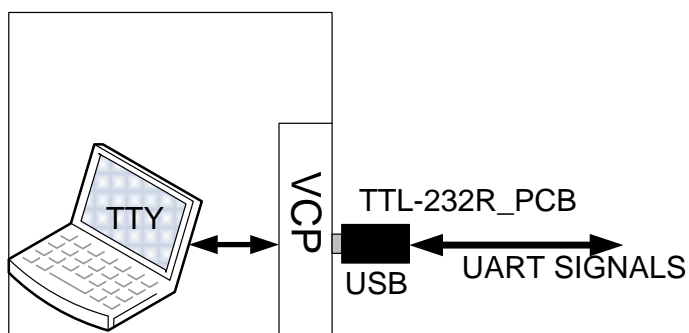

Virtual COM Port

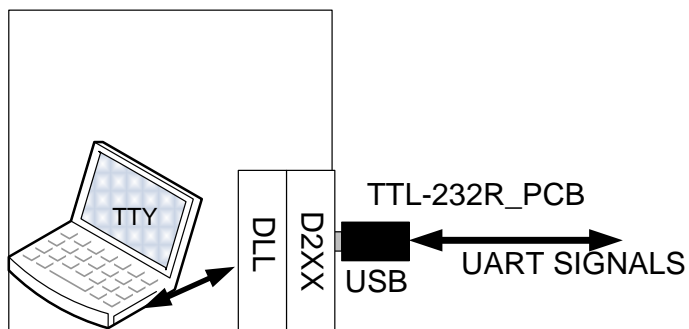

Software application access to USB via D2XX

**Figure 1.1 Using the TTL-232R-PCB**

## 1.1 Part Number

The following Table 1.1 gives details of the available TTL-232R-PCB.

Part Number	Description
TTL-232R-5V-PCB	USB to UART PCB with selectable +5V TTL level UART signals.
TTL-232R-3V3-PCB	USB to UART PCB with selectable +3.3V TTL level UART signals.

**Table 1.1 TTL-232R-PCB Part Number**

## 1.2 USB Compliant

The TTL-232R-PCB is fully compliant with the USB 2.0 specification



---

## Table of Contents

<b>1</b>	<b>Description .....</b>	<b>1</b>
1.1	Part Number.....	2
1.2	USB Compliant .....	2
<b>2</b>	<b>Typical Applications.....</b>	<b>4</b>
2.1	Driver Support .....	4
2.2	Features.....	5
<b>3</b>	<b>Features of FT232R applicable to TTL-232R PCB .....</b>	<b>6</b>
<b>4</b>	<b>TTL-232R-PCB Connector Pin Out and Mechanical details.....</b>	<b>8</b>
4.1	TTL-232R-PCB Signal Descriptions .....	9
4.2	TTL-232R-PCB +5V/+3.3V Selection.....	9
4.3	TTL-232R-PCB Electrical Parameters.....	9
<b>5</b>	<b>TTL-232R-PCB Circuit Schematic .....</b>	<b>11</b>
<b>6</b>	<b>Contact Information .....</b>	<b>12</b>
<b>Appendix A - PCB EEPROM Configuration .....</b>		<b>13</b>
<b>Appendix B - List of Figures and Tables.....</b>		<b>14</b>
<b>Appendix C - Revision History .....</b>		<b>15</b>

## 2 Typical Applications

- USB to Serial TTL Level Converter
- Upgrading Legacy Peripherals to USB
- Interface Microcontroller UART or I/O to USB
- Interface FPGA / PLD to USB
- Replace MAX232 type level shifters allowing for direct connection of products to PC via USB
- USB Instrumentation PC interface
- USB Industrial Control
- USB Software / Hardware Encryption Dongles

### 2.1 Driver Support

#### **Royalty free VIRTUAL COM PORT (VCP) DRIVERS for...**

- Windows 98, 98SE, ME, 2000, Server 2003, XP and Server 2008
- Windows XP and XP 64-bit
- Windows Vista and Vista 64-bit
- Windows XP Embedded
- Windows CE 4.2, 5.0 and 6.0
- Mac OS 8/9, OS-X
- Linux 2.4 and greater

#### **Royalty free D2XX Direct Drivers (USB Drivers + DLL S/W Interface)**

- Windows 98, 98SE, ME, 2000, Server 2003, XP and Server 2008
- Windows XP and XP 64-bit
- Windows Vista and Vista 64-bit
- Windows XP Embedded
- Windows CE 4.2, 5.0 and 6.0
- Linux 2.4 and greater

The drivers listed above are all available to download for free from **www.ftdichip.com**. Various 3rd Party Drivers are also available for various other operating systems - see **www.ftdichip.com** for details.

## 2.2 Features

- TTL-232R\_PCB provides a USB to TTL Serial UART interface.
- On board FT232RQ provides single chip USB to asynchronous serial data transfer interface.
- Entire USB protocol handled by the electronics on the PCB.
- Connect directly to a microcontroller UART or I/O pins.
- UART interface support for 7 or 8 data bits, 1 or 2 stop bits and odd / even / mark / space / no parity.
- Fully assisted hardware (RTS#/CTS#) or X-On / X-Off software handshaking.
- Data transfer rates from 300 baud to 3 Mbaud at TTL levels.
- Internal EEPROM with user writeable area.
- Selectable +3.3V or +5V CMOS drive outputs and 5V safe TTL inputs makes the TTL-232R\_PCB easy to interface to 5V MCU's.
- FTDI's royalty-free VCP allow for communication as a standard emulated COM port and D2XX 'direct' drivers provide DLL application programming interface.
- Support for FT232R FTDIChip-ID™ feature for improved security.
- PCB is USB Powered - no external supply required.
- +5V or +3.3V output allows external logic to be powered from the USB port.
- 6 outputs provide Tx, Rx, RTS#, CTS#, VCC and GND.
- Low USB bandwidth consumption.
- UHCI / OHCI / EHCI host controller compatible.
- USB 2.0 Full Speed compatible.
- -40°C to +85°C operating temperature range.

### 3 Features of FT232R applicable to TTL-232R PCB

The TTL-232R\_PCB uses FTDI's FT232RQ USB to serial IC device. This section summarises the key features of the FT232RQ which apply to the TTL-232R\_PCB USB to serial TTL converter. For further details, and a full features and enhancements description consult the FT232R datasheet, this is available from [www.ftdichip.com](http://www.ftdichip.com).

**Internal EEPROM.** The internal EEPROM is used to store USB Vendor ID (VID), Product ID (PID), device serial number, product description string and various other USB configuration descriptors. Each FT232RQ is supplied with the internal EEPROM pre-programmed as described in **Contact Information**

#### Head Office – Glasgow, UK

Future Technology Devices International Limited  
Unit 1, 2 Seaward Place,  
Glasgow G41 1HH  
United Kingdom  
Tel: +44 (0) 141 429 2777  
Fax: +44 (0) 141 429 2758

E-mail (Sales) [sales1@ftdichip.com](mailto:sales1@ftdichip.com)  
E-mail (Support) [support1@ftdichip.com](mailto:support1@ftdichip.com)  
E-mail (General Enquiries) [admin1@ftdichip.com](mailto:admin1@ftdichip.com)  
Web Site URL <http://www.ftdichip.com>  
Web Shop URL <http://www.ftdichip.com>

#### Branch Office – Taipei, Taiwan

Future Technology Devices International Limited (Taiwan)  
2F, No. 516, Sec. 1, NeiHu Road  
Taipei 114  
Taiwan, R.O.C.  
Tel: +886 (0) 2 8797 1330  
Fax: +886 (0) 2 8751 9737

E-mail (Sales) [tw.sales1@ftdichip.com](mailto:tw.sales1@ftdichip.com)  
E-mail (Support) [tw.support1@ftdichip.com](mailto:tw.support1@ftdichip.com)  
E-mail (General Enquiries) [tw.admin1@ftdichip.com](mailto:tw.admin1@ftdichip.com)  
Web Site URL <http://www.ftdichip.com>

#### Branch Office – Hillsboro, Oregon, USA

Future Technology Devices International Limited (USA)  
7235 NW Evergreen Parkway, Suite 600  
Hillsboro, OR 97123-5803  
USA  
Tel: +1 (503) 547 0988  
Fax: +1 (503) 547 0987

E-Mail (Sales) [us.sales@ftdichip.com](mailto:us.sales@ftdichip.com)  
E-Mail (Support) [us.support@ftdichip.com](mailto:us.support@ftdichip.com)  
E-Mail (General Enquiries) [us.admin@ftdichip.com](mailto:us.admin@ftdichip.com)  
Web Site URL <http://www.ftdichip.com>

#### Branch Office – Shanghai, China

Future Technology Devices International Limited (China)  
Room 408, 317 Xianxia Road,  
ChangNing District,  
ShangHai, China

Tel: +86 (21) 62351596  
Fax: +86(21) 62351595

E-Mail (Sales): [cn.sales@ftdichip.com](mailto:cn.sales@ftdichip.com)

E-Mail (Support): [cn.support@ftdichip.com](mailto:cn.support@ftdichip.com)  
E-Mail (General Enquiries): [cn.admin1@ftdichip.com](mailto:cn.admin1@ftdichip.com)  
Web Site URL: <http://www.ftdichip.com>

### **Distributor and Sales Representatives**

Please visit the Sales Network page of the FTDI Web site for the contact details of our distributor(s) and sales representative(s) in your country.

Appendix A - PCB EEPROM Configuration. A user area of the internal EEPROM is available to system designers to allow storing additional data. The internal EEPROM descriptors can be programmed in circuit, over USB without any additional voltage requirement. It can be programmed using the FTDI utility software called [FT\\_PROG](#), which can be downloaded from FTDI Utilities on the FTDI website ([www.ftdichip.com](http://www.ftdichip.com)).

**Lower Operating and Suspend Current.** The FT232R has a low 15mA operating supply current and a very low USB suspend current of approximately 70µA.

**Low USB Bandwidth Consumption.** The USB interface of the FT232R, and therefore the TTL-232R\_PCB has been designed to use as little as possible of the total USB bandwidth available from the USB host controller.

**High Output Drive Option.** The UART interface I/O pins on the TTL-232R\_PCB (RXD, TXD, RTS#, and CTS#) can be configured to use the FT232R's high output drive option. This option allows the FT232R I/O pins to drive up to three times the standard signal drive level. This allows multiple devices to be driven, or devices that require a greater signal drive strength to be interfaced on the PCB. This option is enabled in the internal EEPROM.

**UART Pin Signal Inversion.** The sense of each of the UART signals can be individually inverted by configuring options in the internal EEPROM. For example CTS# (active low) can be changed to CTS (active high), or TXD can be changed to TXD#.

**FTDICHIP-ID™.** The FT232R includes the new FTDICHIP-ID™ security dongle feature. This FTDICHIP-ID™ feature allows a unique number to be burnt into each FT\_232RQ during manufacture. This number cannot be reprogrammed. This number is only readable over USB can be used to form the basis of a security dongle which can be used to protect any customer application software being copied. This allows the possibility of using the TTL-232R\_PCB as a dongle for software licensing. Further to this, a renewable license scheme can be implemented based on the FTDICHIP-ID™ number when encrypted with other information. This encrypted number can be stored in the user area of the FT232R internal EEPROM, and can be decrypted, then compared with the protected FTDICHIP-ID™ to verify that a license is valid. Web based applications can be used to maintain product licensing this way. An application note, AN232R-02, available from FTDI website ([www.ftdichip.com](http://www.ftdichip.com)) describes this feature.

**Extended Operating Temperature Range -** The TTL-232R\_PCB is capable of operating over an extended temperature range of -40° to +85°C thus allowing it to be used in automotive or industrial applications.



#### 4 TTL-232R-PCB Connector Pin Out and Mechanical details

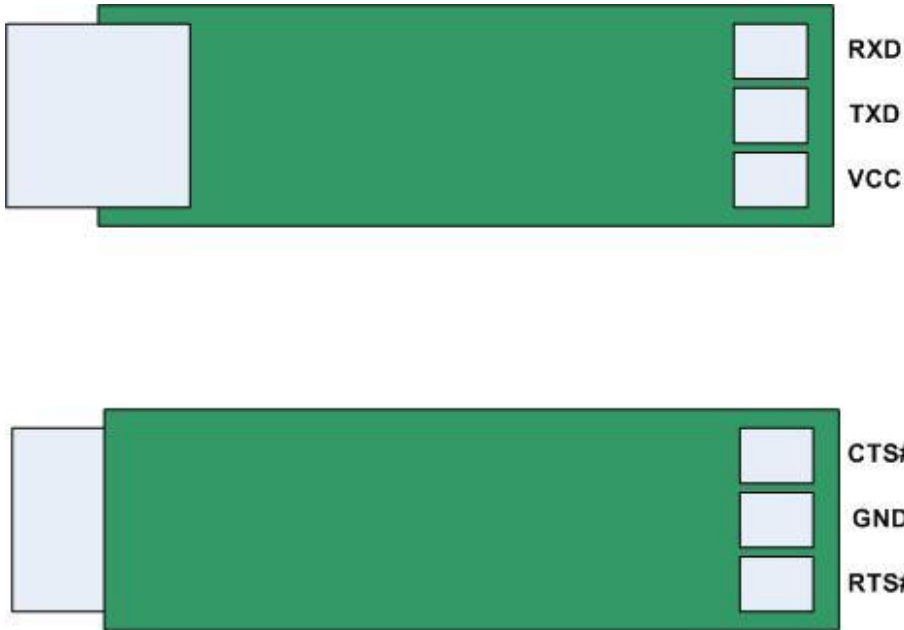

### TTL232R PCB PADS

Figure 4.1 TTL-232R-PCB Pin Out (Top is TOP View, Bottom is BOTTOM View)

The mechanical details of the PCB are shown in the following diagram Figure 4.2

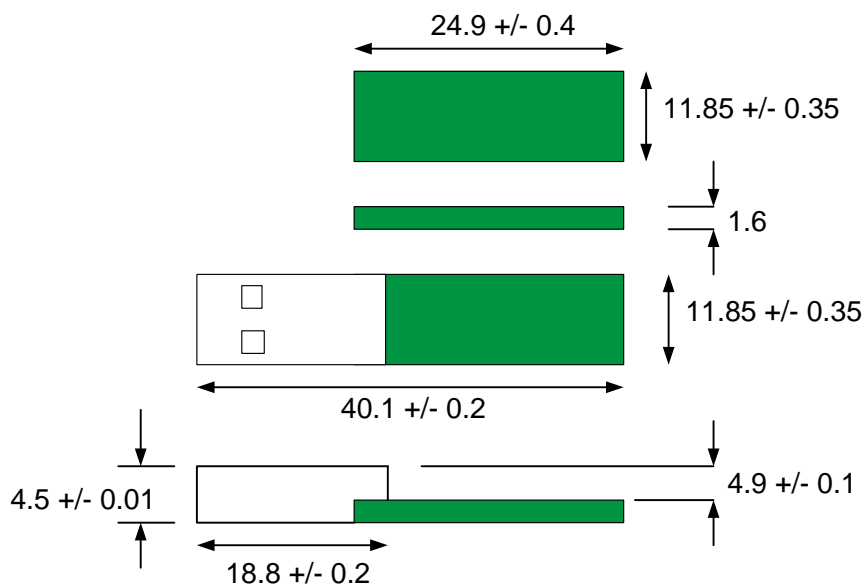

Dimensions in mm

Figure 4.2 TTL-232R TTL-232R-PCB, Mechanical Details

#### 4.1 TTL-232R-PCB Signal Descriptions

Name	Type	Description
GND	GND	Device ground supply pin.
CTS#	Input	Clear to Send Control input / Handshake signal.
VCC	Output	+5V output,
TXD	Output	Transmit Asynchronous Data output.
RXD	Input	Receive Asynchronous Data input.
RTS#	Output	Request To Send Control Output / Handshake signal.

**Table 4.1 TTL-232R-PCB Signal Descriptions**

#### 4.2 TTL-232R-PCB +5V/+3.3V Selection

Selection of whether the UART signal are +3.3V levels or +5V levels is done using resistors. The following table gives details of what resistors are required for the two different voltage levels. Note that the VCC output signal will always drive at +5V.

Resistor R1	Resistor R2	Description
Fitted	Not Fitted	UART signals are +5V level signals
Not Fitted	Fitted	UART signals are +3.3V level signals

**Table 4.2 UART Signal Level Selection**

#### 4.3 TTL-232R-PCB Electrical Parameters

Parameter	Description	Minimum	Typical	Maximum	Units	Conditions
VCC	Output Power Voltage	4.25	5.0	5.25	V	Dependant on the USB port that the TTL-232R-PCB is connected to
I <sub>o</sub>	Output Power Current	-		75	mA	
T	Operating Temperature Range	-40		+85	°C	

**Table 4.3 TTL-232R-PCB I/O Operating Parameters**

Parameter	Description	Minimum	Typical	Maximum	Units	Conditions
V <sub>oh</sub>	Output Voltage High	3.2	4.1	4.9	V	I source = 6mA
V <sub>ol</sub>	Output Voltage Low	0.3	0.4	0.6	V	I sink = 6mA
V <sub>in</sub>	Input Switching Threshold	1.0	1.2	1.5	V	
V <sub>Hys</sub>	Input Switching Hysteresis	20	25	30	mV	

**Table 4.4 TTL-232R-PCB I/O Pin Characteristics (+5V level signals)**

Parameter	Description	Minimum	Typical	Maximum	Units	Conditions
Voh	Output Voltage High	2.2	2.8	3.2	V	I source = 3mA
Vol	Output Voltage Low	0.3	0.4	0.6	V	I sink = 8mA
Vin	Input Switching Threshold	1.0	1.2	1.5	V	
VHys	Input Switching Hysteresis	20	25	30	mV	

**Table 4.5 TTL-232R-PCB I/O Pin Characteristics (+3.3V level signals)**

## 5 TTL-232R-PCB Circuit Schematic

The circuit schematic of the TTL-232R-PCB, utilising the FTDI FT232R, is shown in Figure 5.1

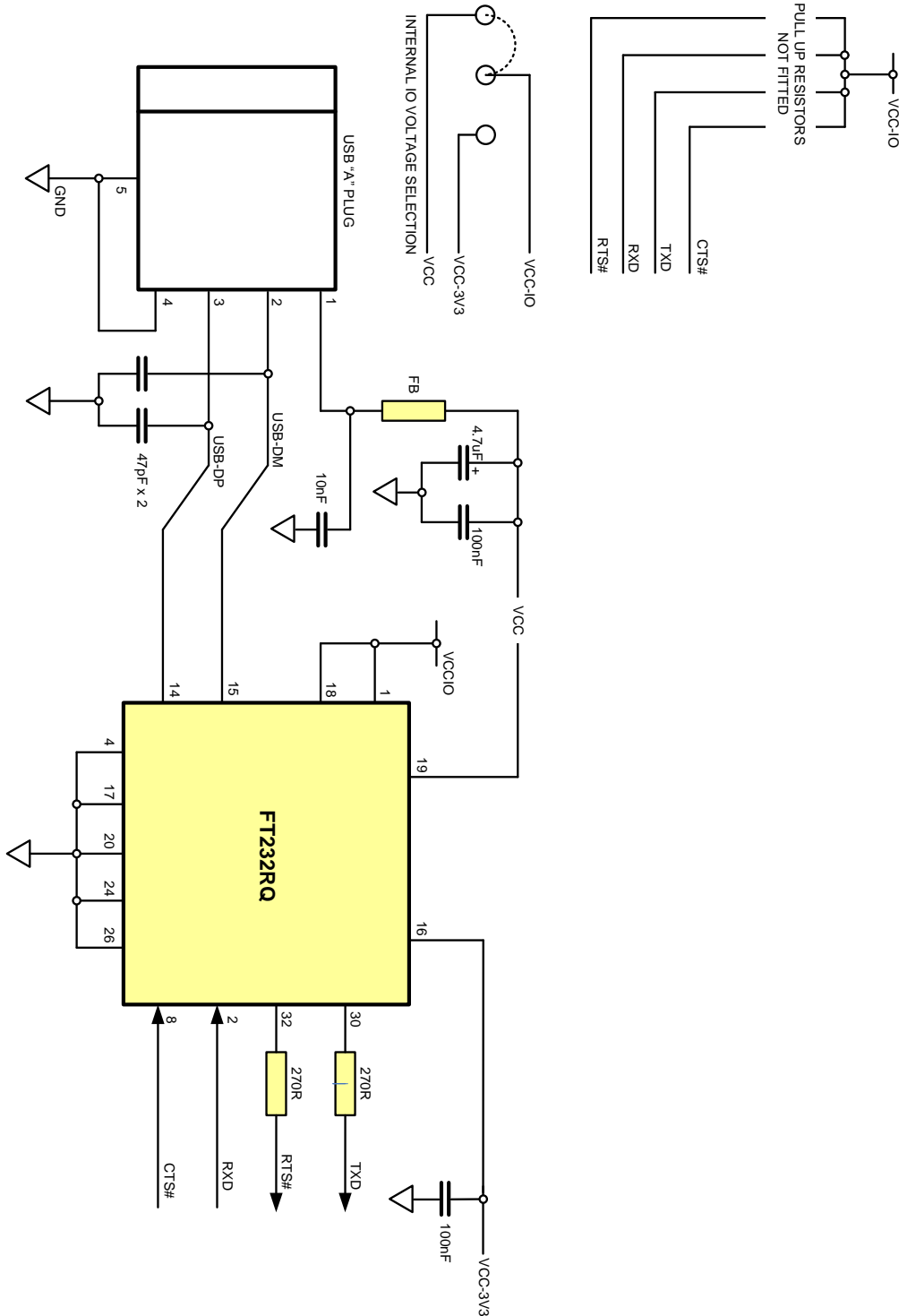

**Figure 5.1 Circuit Schematic of TTL-232R-PCB.**

## 6 Contact Information

### Head Office – Glasgow, UK

Future Technology Devices International Limited  
Unit 1, 2 Seaward Place,  
Glasgow G41 1HH  
United Kingdom  
Tel: +44 (0) 141 429 2777  
Fax: +44 (0) 141 429 2758

E-mail (Sales) [sales1@ftdichip.com](mailto:sales1@ftdichip.com)  
E-mail (Support) [support1@ftdichip.com](mailto:support1@ftdichip.com)  
E-mail (General Enquiries) [admin1@ftdichip.com](mailto:admin1@ftdichip.com)  
Web Site URL <http://www.ftdichip.com>  
Web Shop URL <http://www.ftdichip.com>

### Branch Office – Taipei, Taiwan

Future Technology Devices International Limited (Taiwan)  
2F, No. 516, Sec. 1, NeiHu Road  
Taipei 114  
Taiwan, R.O.C.  
Tel: +886 (0) 2 8797 1330  
Fax: +886 (0) 2 8751 9737

E-mail (Sales) [tw.sales1@ftdichip.com](mailto:tw.sales1@ftdichip.com)  
E-mail (Support) [tw.support1@ftdichip.com](mailto:tw.support1@ftdichip.com)  
E-mail (General Enquiries) [tw.admin1@ftdichip.com](mailto:tw.admin1@ftdichip.com)  
Web Site URL <http://www.ftdichip.com>

### Branch Office – Hillsboro, Oregon, USA

Future Technology Devices International Limited (USA)  
7235 NW Evergreen Parkway, Suite 600  
Hillsboro, OR 97123-5803  
USA  
Tel: +1 (503) 547 0988  
Fax: +1 (503) 547 0987

E-Mail (Sales) [us.sales@ftdichip.com](mailto:us.sales@ftdichip.com)  
E-Mail (Support) [us.support@ftdichip.com](mailto:us.support@ftdichip.com)  
E-Mail (General Enquiries) [us.admin@ftdichip.com](mailto:us.admin@ftdichip.com)  
Web Site URL <http://www.ftdichip.com>

### Branch Office – Shanghai, China

Future Technology Devices International Limited (China)  
Room 408, 317 Xianxia Road,  
ChangNing District,  
ShangHai, China

Tel: +86 (21) 62351596  
Fax: +86(21) 62351595

E-Mail (Sales): [cn.sales@ftdichip.com](mailto:cn.sales@ftdichip.com)  
E-Mail (Support): [cn.support@ftdichip.com](mailto:cn.support@ftdichip.com)  
E-Mail (General Enquiries): [cn.admin1@ftdichip.com](mailto:cn.admin1@ftdichip.com)  
Web Site URL: <http://www.ftdichip.com>

### Distributor and Sales Representatives

Please visit the Sales Network page of the FTDI Web site for the contact details of our distributor(s) and sales representative(s) in your country.

## Appendix A - PCB EEPROM Configuration

Each TTL-232R-PCB is controlled by the FTDI FT232R IC. This FT232R device contains an EEPROM which contains the USB configuration descriptors for that device. When the PCB is plugged into a PC or a USB reset is performed, the PC will read these descriptors. The default values stored into the internal EEPROM are defined in Table 0.1 Default Internal EEPROM Configuration

Parameter	Value	Notes
USB Vendor ID (VID)	0403h	FTDI default VID (hex)
USB Product UD (PID)	6001h	FTDI default PID (hex)
Serial Number Enabled?	Yes	
Serial Number	See Note	A unique serial number is generated and programmed into the EEPROM during device final test.
Pull down I/O Pins in USB Suspend	Disabled	Enabling this option will make the device pull down on the UART interface lines when the power is shut off (PWREN# is high).
Manufacturer Name	FTDI	
Product Description	See note	TTL-232R-PCB
Max Bus Power Current	90mA	
Power Source	Bus Powered	
Device Type	FT232R	
USB Version	0200	Returns USB 2.0 device description to the host. Note: The device is be a USB 2.0 Full Speed device (12Mb/s) as opposed to a USB 2.0 High Speed device (480Mb/s).
Remote Wake Up	Disabled	
High Current I/Os	Enabled	Enables the high drive level on the UART and CBUS I/O pins.
Load VCP Driver	Enabled	Makes the device load the VCP driver interface for the device.
Invert TXD	Disabled	Signal on this pin becomes TXD# if enable.
Invert RXD	Disabled	Signal on this pin becomes RXD# if enable.
Invert RTS#	Disabled	Signal on this pin becomes RTS if enable.
Invert CTS#	Disabled	Signal on this pin becomes CTS if enable.

**Table 0.1 Default Internal EEPROM Configuration**

The internal EEPROM on the PCB can be re-programmed over USB using the utility program [FT\\_PROG](#). [FT\\_PROG](#) can be downloaded from the [www.ftdichip.com](http://www.ftdichip.com). Version 2.8a or later is required for the FT232R chip. Users who do not have their own USB Vendor ID but who would like to use a unique Product ID in their design can apply to FTDI for a free block of unique PIDs. Contact FTDI support for this service.

---

## Appendix B - List of Figures and Tables

### List of Figures

Figure 1.1 Using the TTL-232R-PCB .....	1
Figure 4.1 TTL-232R-PCB Pin Out (Top is TOP View, Bottom is BOTTOM View) .....	8
Figure 4.2 TTL-232R TTL-232R-PCB, Mechanical Details.....	8
Figure 5.1 Circuit Schematic of TTL-232R-PCB. ....	11

### List of Tables

Table 1.1 TTL-232R-PCB Part Number .....	2
Table 4.1 TTL-232R-PCB Signal Descriptions .....	9
Table 4.2 UART Signal Level Selection .....	9
Table 4.3 TTL-232R-PCB I/O Operating Parameters .....	9
Table 4.4 TTL-232R-PCB I/O Pin Characteristics (+5V level signals).....	9
Table 4.5 TTL-232R-PCB I/O Pin Characteristics (+3.3V level signals).....	10
Table 0.1 Default Internal EEPROM Configuration.....	13

## Appendix C - Revision History

Version 1.00	First Release	8 <sup>th</sup> August 2008
Version 1.01	Added RoHS compliant statement in section 1 Added section 1.2 USB Compliant Logo Updated Contact details Replaced reference MProg with FT_Prog	2 <sup>nd</sup> September 2010





Компания «ЭлектроПласт» предлагает заключение долгосрочных отношений при поставках импортных электронных компонентов на взаимовыгодных условиях!

Наши преимущества:

- Оперативные поставки широкого спектра электронных компонентов отечественного и импортного производства напрямую от производителей и с крупнейших мировых складов;
- Поставка более 17-ти миллионов наименований электронных компонентов;
- Поставка сложных, дефицитных, либо снятых с производства позиций;
- Оперативные сроки поставки под заказ (от 5 рабочих дней);
- Экспресс доставка в любую точку России;
- Техническая поддержка проекта, помощь в подборе аналогов, поставка прототипов;
- Система менеджмента качества сертифицирована по Международному стандарту ISO 9001;
- Лицензия ФСБ на осуществление работ с использованием сведений, составляющих государственную тайну;
- Поставка специализированных компонентов (Xilinx, Altera, Analog Devices, Intersil, Interpoint, Microsemi, Aeroflex, Peregrine, Syfer, Eurofarad, Texas Instrument, Miteq, Cobham, E2V, MA-COM, Hittite, Mini-Circuits, General Dynamics и др.);

Помимо этого, одним из направлений компании «ЭлектроПласт» является направление «Источники питания». Мы предлагаем Вам помощь Конструкторского отдела:

- Подбор оптимального решения, техническое обоснование при выборе компонента;
- Подбор аналогов;
- Консультации по применению компонента;
- Поставка образцов и прототипов;
- Техническая поддержка проекта;
- Защита от снятия компонента с производства.



#### Как с нами связаться

**Телефон:** 8 (812) 309 58 32 (многоканальный)

**Факс:** 8 (812) 320-02-42

**Электронная почта:** [org@eplast1.ru](mailto:org@eplast1.ru)

**Адрес:** 198099, г. Санкт-Петербург, ул. Калинина, дом 2, корпус 4, литера А.