

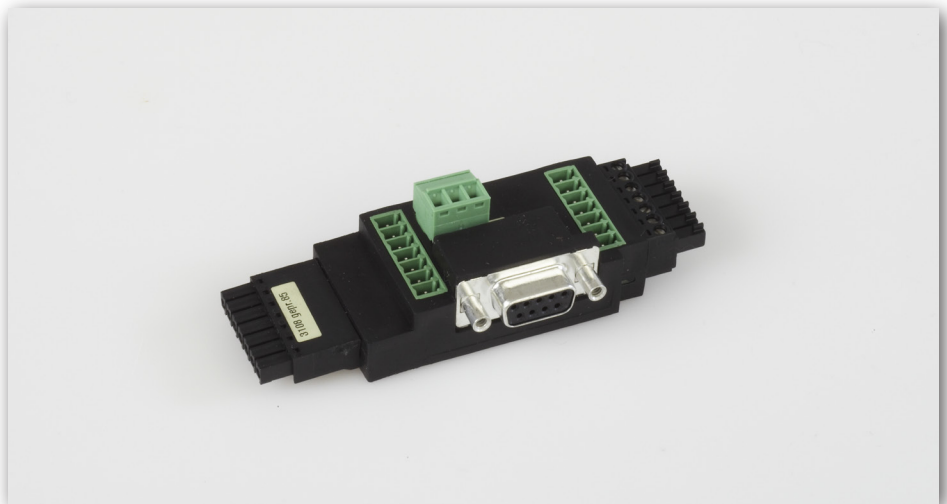

PC-INTERFACE RS 232

FOR THYRO-S AND THYRO-A

August 2014 2.000.000.845 DE/EN - V4



CONTENT

1. Notes to these operating instructions	4
1.1 Information duty	4
1.2 Validity	4
1.3 Loss of guarantee	4
1.4 Handling	5
2. Introduction	6
3. Delivery components	6
4. Features	6
5. Connections	7
5.1 Thyro-S	8
5.2 Thyro-A	8
6. Start-Up	9
6.1 Set point processing using PC-Interface RS232	9
7. Other accessories	9

CONTACT

TECHNICAL QUERIES

Do you have any technical queries regarding the subjects dealt with in these operating instructions?

If so, please get in touch with our team for power controllers:

Phone +49 (0) 2902 763-520

COMMERCIAL QUERIES

Do you have any commercial queries on power controllers?

If so, please get in touch with our team for power controllers.

Phone +49 (0) 2902 763-558

SERVICE

Advanced Energy Industries GmbH

Branch Office Warstein-Belecke

Emil-Siepmann-Straße 32

D-59581 Warstein

Phone +49 (0) 2902 763-0

<http://www.advanced-energy.com>

COPYRIGHT

No part of these operating instructions may be transmitted, reproduced and/ or copied by any electronic or mechanical means without the express prior written permission of Advanced Energy.

© Copyright Advanced Energy Industries GmbH 2014.

All rights reserved.

FURTHER INFORMATION ON COPYRIGHT

Thyro-™, Thyro-S™, Thyro-A™ are registered trademarks of Advanced Energy Industries GmbH.

All other company and product names are (registered) trademarks of the respective owners.

1. NOTES TO THESE OPERATING INSTRUCTIONS

1.1 INFORMATION DUTY

The presented operations manual shall carefully be read by all persons deployed for work using and employing the PC-Interface RS232 (hereinafter called the "unit") prior to assembly and the initial start-up of the unit.

This operations manual is a part of the unit. The operator of the unit is committed to provide this operations manual to all persons without limitation, who transport the unit, start it up, maintain it, or perform other work tasks to it.

1.2 VALIDITY

This operations manual resembles the technical status of the unit at the time of publication. Advanced Energy reserves the right to implement content and technical changes in comparison to the information of these operating instructions.

1.3 LOSS OF GUARANTEE

Our supplies and services are based on the General Delivery Terms for Products of the Electro-Technical Industry, as well as on our General Sales Terms. Changes made to the information of this operations manual, especially to technical data, operational instructions, dimensions and weights, shall remain our reserved right at all times. We request that complaints regarding delivered products shall be put forward within eight days upon receipt of the products including the package notes as attached. Claims made later cannot receive consideration. Advanced Energy shall annul all possible obligations, such as guarantee commitments, service agreements etc., which may be agreed upon by Advanced Energy and its distributors, without prior notice, if purchased spare parts other than original Advanced Energy or such other than those purchased via Advanced Energy are used for maintenance and repair.

1.4 HANDLING

This operations manual is structured in a manner so that according expert personnel may perform all work necessary for commissioning, maintenance, and repair. Certain process steps are related to figures in order to clarify and to ease necessary work. If threats to personnel and material cannot be ruled out for certain work, such tasks are marked with a pictogram, from which the according content for safety regulations may be extracted.

2. INTRODUCTION

The following operating instructions merely serve as a supplement and apply only in connection with the operating instructions of the Advanced Energy power controllers Thyro-S and Thyro-A of types H1 and H RL1, as well as H RLP1. Particular attention must be paid to the safety instructions included in them.

3. DELIVERY COMPONENTS

The PC-Interface RS232 for Thyro-S / Thyro-A consists of the following components

- 1 x Interface module with interfaces for Thyro-A, Thyro-S as well as RS232,
- 1 x triple pole terminal,
- this operating manual.

4. FEATURES

The PC-Interface RS232 for Thyro-S / Thyro-A is suitable to connect the above mentioned power controller to a personal computer. This point-to-point communication does not need an address for the power controller.

In combination with the software Thyro-Tool Family (Order-No. 2 000 000 380) visualization and commissioning functions are practicable. The power supply of the PC-Interface is possible via the interfaces (refer to remark in chapter 5).

5. CONNECTIONS

The PC-Interface connects the RS232 socket of a personal computer (9-pole Sub-D plug) with the socket of the internal interface of a power controller.

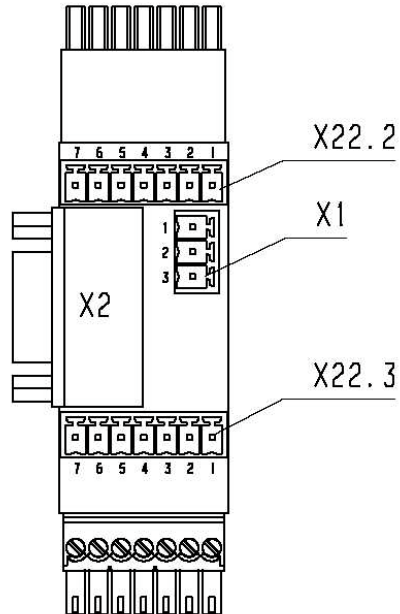

REMARK

The standard cable (with 9-pole Sub-D plug) must not be a zero-modem connection (cable does not have a cross). For the power supply the cable must contain the connections of pins 4 and 7 (handshake). For data transfer pins 2, 3 and 5 are necessary. In case of using a 3-wire connection, as well as using an interface without used pins 4 (DTR) and 7 (RTS), an additional 9-volt power supply is necessary. At the triple pole terminal X1.1 is to connect to +9 Volt (range 7.7V to 12.5V), and X1.3 is to connect to ground.



CAUTION

When plugging and taking off the PC-interface/plug, it is to be made certain, that the power controller is free of voltage (contact danger).

The existing connection at X 22 of the power controller has to be taken off and the interface has to be plugged on the unit. In addition the type plate shows the sides for Thyro-A and Thyro-S (the Thyro-S connection is also recognizable by the screws on the plug).

5.1 THYRO-S

The connection of the interface at Thyro-S corresponds to fig. 1. Then the free upper 7-pin row is intended for the plug that was before on the connection present (set point wiring). The plug is to be put directly below the Thyro-S from left side on to the interface.



FIG. 1 THYRO-S

5.2 THYRO-A

The connection of the interface for Thyro-A 1A power controller corresponds to fig. 2, for Thyro-A 2A it corresponds to fig. 3. The connection of Thyro-A 3A is logically.

Then the free upper 7-pin pin row is intended for the plug that was before on the connection present (Thyro-A 2A: at least the slave connection). The plug is to be put directly below the Thyro-A from right side on to the interface.



FIG. 2 THYRO-A 1A



FIG. 3 THYRO-A 2A

6. START-UP

After connection of the PC-Interface, the power supply of the power controller can be switched on and the Thyro-Tool Family can be started.

6.1 SET POINT PROCESSING USING PC-INTERFACE RS232

If a bridge is connected between the pins X1.2 and X1.3 on the PC-Interface (this corresponds to ground signal at pin 1 at Thyro-A, and ground signal at the pin 4 at Thyro-S), then the power controller processes as set point value only from the Thyro-Tool Family given value.

7. OTHER ACCESSORIES

- RS232 connection cable, length 5 m (Order-no. 0048764)
- Thyro-Tool Family, visualization- and commissioning-software (Order-no. 2.000.000.380)



World Headquarters
1625 Sharp Point Drive
Fort Collins, CO 80525 USA

970.221.4670 Main
970.221.5583 Fax

www.advanced-energy.com

Specifications are subject to change without notice.

© 2014 Advanced Energy Industries, Inc. All rights reserved. Advanced Energy®, Thyro-S™ and Thyro-A™ are trademarks of Advanced Energy Industries, Inc.



Компания «ЭлектроПласт» предлагает заключение долгосрочных отношений при поставках импортных электронных компонентов на взаимовыгодных условиях!

Наши преимущества:

- Оперативные поставки широкого спектра электронных компонентов отечественного и импортного производства напрямую от производителей и с крупнейших мировых складов;
- Поставка более 17-ти миллионов наименований электронных компонентов;
- Поставка сложных, дефицитных, либо снятых с производства позиций;
- Оперативные сроки поставки под заказ (от 5 рабочих дней);
- Экспресс доставка в любую точку России;
- Техническая поддержка проекта, помощь в подборе аналогов, поставка прототипов;
- Система менеджмента качества сертифицирована по Международному стандарту ISO 9001;
- Лицензия ФСБ на осуществление работ с использованием сведений, составляющих государственную тайну;
- Поставка специализированных компонентов (Xilinx, Altera, Analog Devices, Intersil, Interpoint, Microsemi, Aeroflex, Peregrine, Syfer, Eurofarad, Texas Instrument, Miteq, Cobham, E2V, MA-COM, Hittite, Mini-Circuits, General Dynamics и др.);

Помимо этого, одним из направлений компании «ЭлектроПласт» является направление «Источники питания». Мы предлагаем Вам помощь Конструкторского отдела:

- Подбор оптимального решения, техническое обоснование при выборе компонента;
- Подбор аналогов;
- Консультации по применению компонента;
- Поставка образцов и прототипов;
- Техническая поддержка проекта;
- Защита от снятия компонента с производства.



Как с нами связаться

Телефон: 8 (812) 309 58 32 (многоканальный)

Факс: 8 (812) 320-02-42

Электронная почта: org@eplast1.ru

Адрес: 198099, г. Санкт-Петербург, ул. Калинина, дом 2, корпус 4, литера А.