

FEATURES

- Ultra Broad Bandwidth : 50 MHz to 50 GHz
- Functional Bandwidth : 50 MHz to 70 GHz
- 0.7 dB Insertion Loss
- 32 dB Isolation at 50 GHz
- Low Current consumption
 - -10mA for low loss state
 - +10mA for Isolation state
- M/A-COM Tech's unique AlGaAs hetero-junction anode technology
- Silicon Nitride Passivation
- Polymer Scratch protection
- RoHS Compliant* and 260°C Reflow Compatible

DESCRIPTION

The MA4AGSW4 is an Aluminum-Gallium-Arsenide, single pole, four throw (SP4T), PIN diode switch. The switch features enhanced AlGaAs anodes which are formed using M/A-COM Tech's patented hetero-junction technology. This technology produces a switch with less loss than conventional GaAs processes. As much as a 0.3 dB reduction in insertion loss can be realized at 50GHz. These devices are fabricated on an OMCVD epitaxial wafer using a process designed for high device uniformity and extremely low parasitics. The diodes themselves exhibit low series resistance, low capacitance, and fast switching speed. They are fully passivated with silicon nitride and have an additional polymer layer for scratch protection. The protective coating prevents damage to the diode junction and anode air-bridges during handling and assembly. Off chip bias circuitry is required.

APPLICATIONS

The high electron mobility of AlGaAs and the low capacitance of the PIN diodes makes this switch ideal for fast switching, high frequency, multi-throw switch designs. These AlGaAs PIN switches are use in switching arrays for radar systems, radiometers, test equipment and other multi-assembly components.

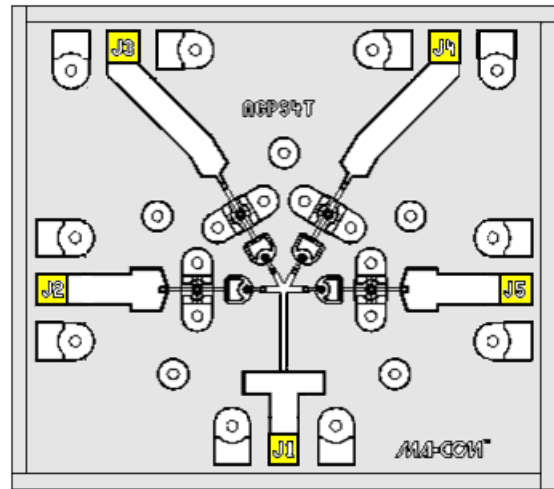

Yellow areas indicate bond pads

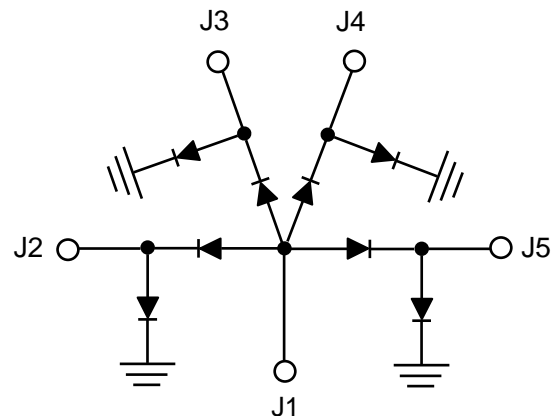

Absolute Maximum Ratings @ T_{AMB} = +25°C

Parameter	Maximum Rating
Operating Temperature	-55°C to +125°C
Storage Temperature	-55°C to +150°C
Incident C.W. RF Power	+23dBm C.W.
Breakdown Voltage	25V
Bias Current	± 25mA
Assembly Temperature	+300°C < 10 sec
Junction Temperature	+175°C

Maximum combined operating conditions for RF Power, D.C. bias, and temperature: +23 dBm C.W. @ 10 mA (per diode) @ +85°C.

* Restrictions on Hazardous Substances, European Union Directive 2002/95/EC.

**Electrical Specifications @ T_A = 25°C, +/-10mA bias current
(On-wafer measurements)**

RF SPECIFICATIONS					
PARAMETER	FREQUENCY BAND	MIN	TYP	MAX	UNITS
INSERTION LOSS	0.05 - 18 GHz		0.7	0.8	dB
	18 - 50 GHz		1.0	1.4	dB
ISOLATION	0.05 - 18 GHz	25	41		dB
	18 - 50 GHz	25	32		dB
INPUT RETURN LOSS	0.05 - 18 GHz	10	21		dB
	18 - 50 GHz	10	22		dB
OUTPUT RETURN LOSS	0.05 - 18 GHz	10	26		dB
	18 - 50 GHz	10	17		dB
SWITCHING SPEED	10 GHz		20		nS

***Note:**

Typical switching speed is measured from 10% to 90% of the detected RF voltage driven by a TTL compatible driver. Driver output parallel RC network uses a capacitor between 390 pF - 560 pF and a resistor between 150 - 220 Ohms to achieve 20 ns rise and fall times.

Typical R.F. Performance (Probed on Wafer) @ +25°C

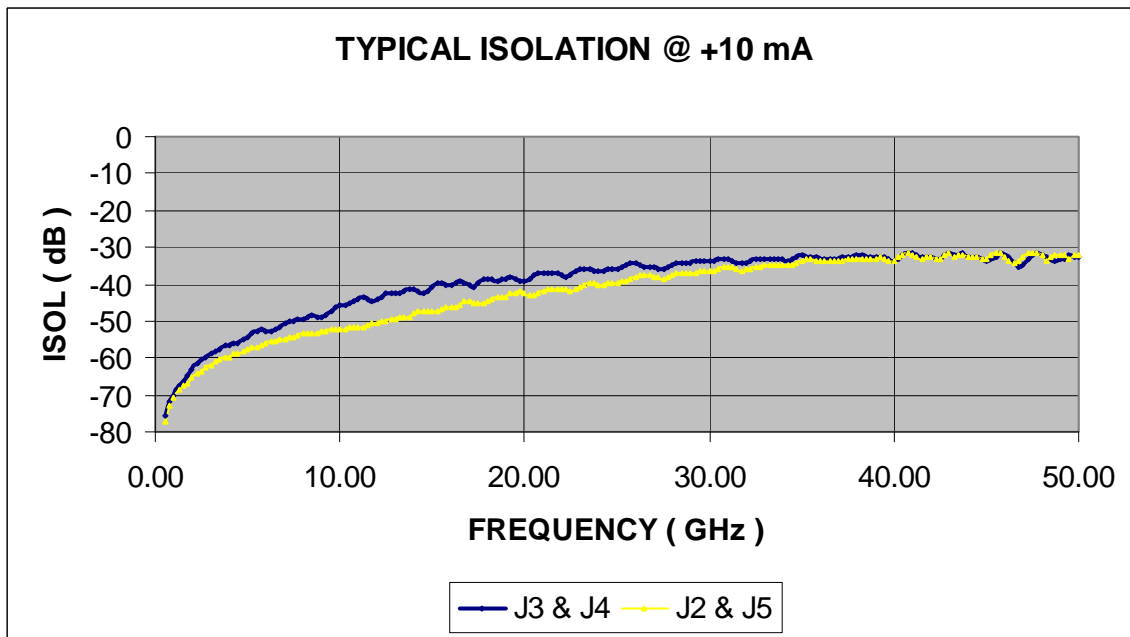
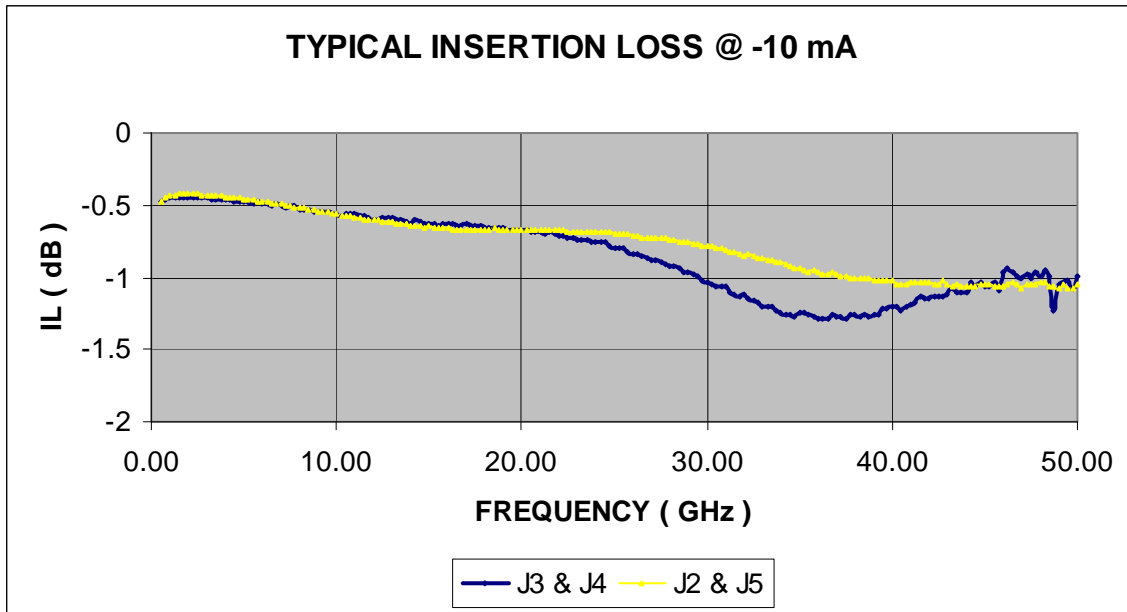

Typical RF Performance (Probed on wafer) @ +25°C

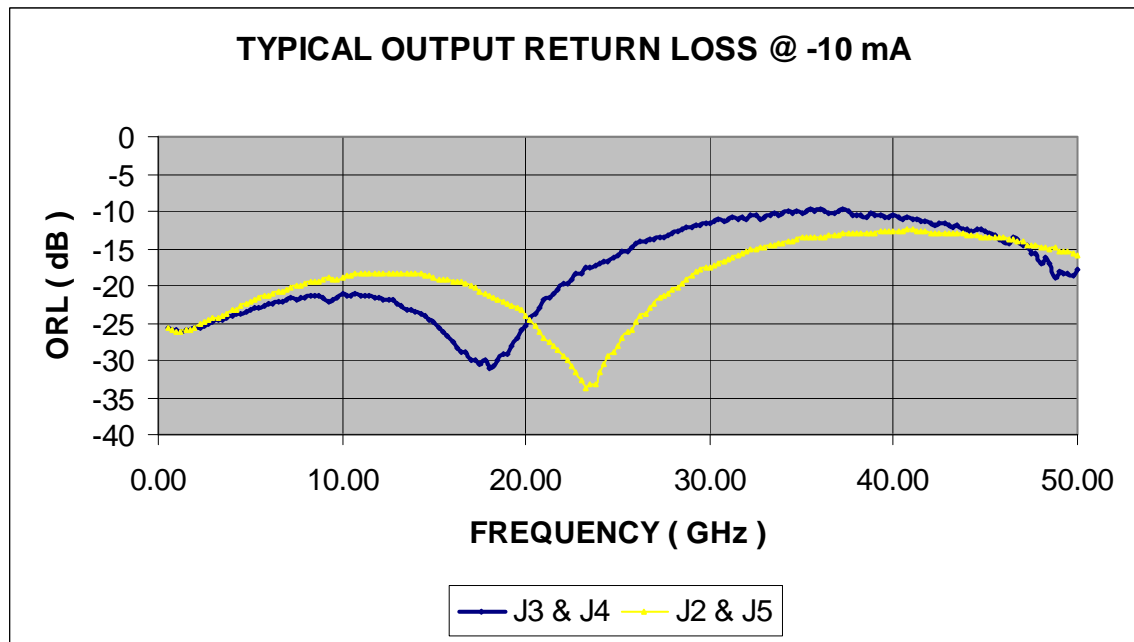
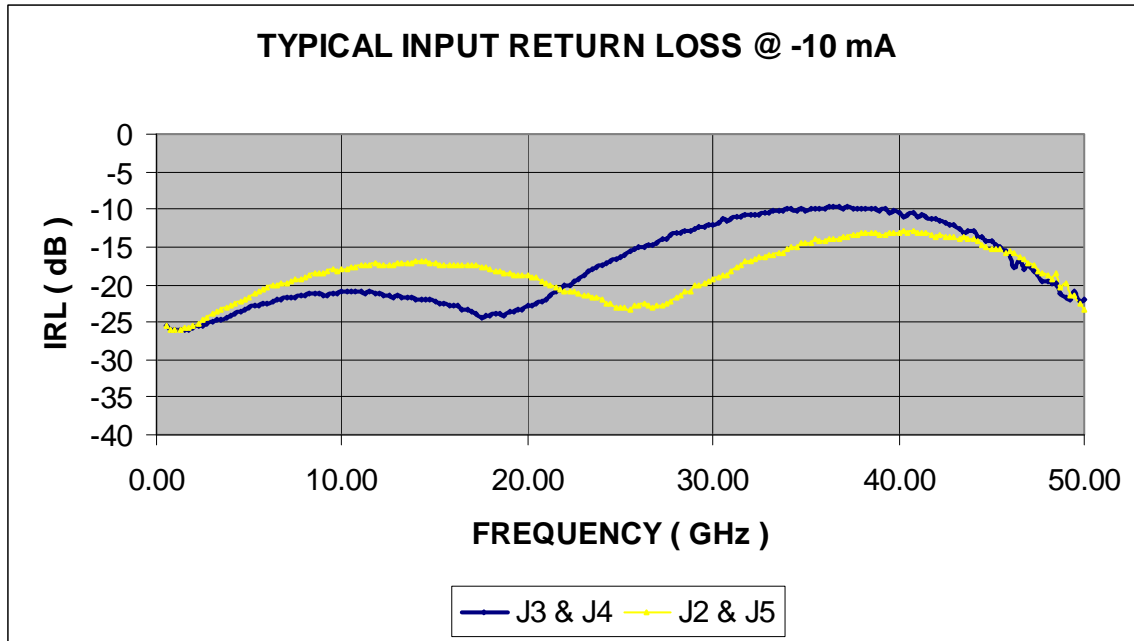

Operation of the MA4AGSW4 Switch

The simultaneous application of a negative DC current to the low loss port and positive DC current to the remaining isolated switching ports is required for the operation of the MA4AGSW4, AIGaAs, PIN switch. The backside area of the die is the RF and DC return ground plane. The DC return is connected to the common port J1. The forward bias voltage at J2, J3, J4 & J5 will not exceed ± 1.6 volts and is typically ± 1.4 volts with supply current of ± 30 mA). In the low loss state, the series diode must be forward biased and the shunt diode reverse biased. While for the Isolated port, the shunt diode is forward biased and the series diode is reverse biased. The bias network design shown below should yield > 30 dB RF to DC Isolation.

Available for use in conjunction with M/A-COM Tech's line of AIGaAs switches are two, fully integrated, broadband, monolithic, bias networks which may be used as an alternative to the suggested individual component bias network shown below. Refer to datasheets for the [MA4BN1840-1](#) and [MA4BN1840-2](#) for additional information.

The lowest insertion loss, P1dB, IP³, and switching speed is achieved by using a voltage pull-up resistor in the DC return path, (J1). A minimum value of $|-2V|$ is recommended at this return node, which is achievable with a standard, $\pm 5V$ TTL Controlled PIN Diode Driver.

MA4AGSW4 Schematic with a Typical External 2-18 GHz Bias Network

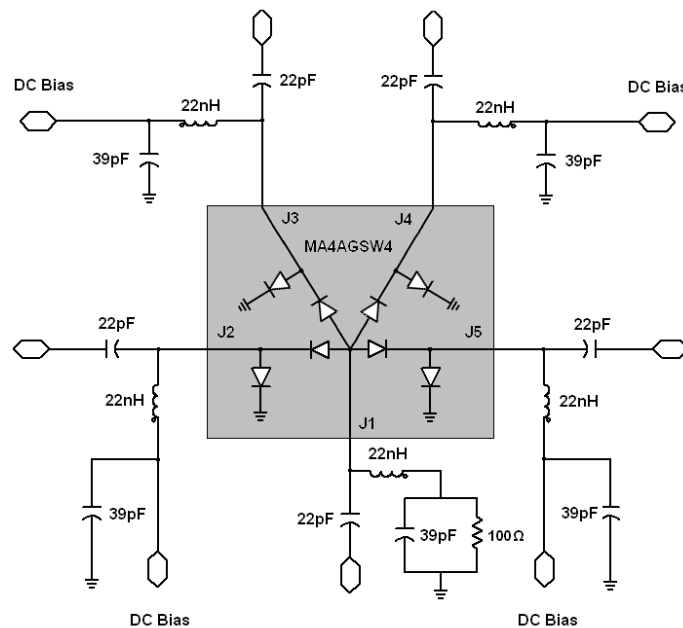

TYPICAL DRIVER CONNECTIONS

CONTROL LEVEL (DC CURRENT)				CONDITION OF RF OUTPUT			
J2	J3	J4	J5	J2-J1	J3-J1	J4-J1	J5-J1
-10mA	+10mA	+10mA	+10mA	Low Loss	Isolation	Isolation	Isolation
+10mA	-10mA	+10mA	+10mA	Isolation	Low Loss	Isolation	Isolation
+10mA	+10mA	-10mA	+10mA	Isolation	Isolation	Low Loss	Isolation
+10mA	+10mA	+10mA	-10mA	Isolation	Isolation	Isolation	Low Loss

Chip Dimensions and Bonding Pad Locations (In Yellow)

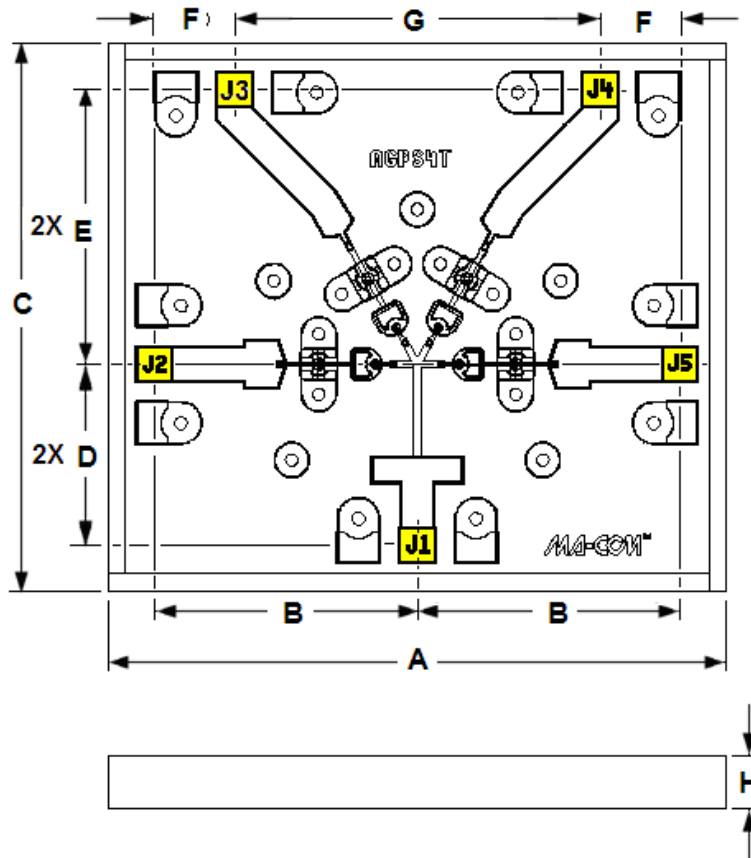

DIM	mils			mm		
	Minimum	Nominal	Maximum	Minimum	Nominal	Maximum
A	66.0	67.0	68.0	1.676	1.702	1.727
B	28.5	29.0	29.5	0.724	0.737	0.749
C	5.9	6.0	6.1	1.499	1.524	1.549
D	19.5	20.0	20.5	0.495	0.508	0.521
E	29.5	30.0	30.5	0.749	0.762	0.775
F	8.5	9.0	9.5	0.216	0.229	0.241
G	39.5	40.0	40.5	1.003	1.016	1.029
H	3.5	4.0	4.5	0.089	0.102	0.114
PADS	3.5	4.0	4.5	0.089	0.102	0.114

ASSEMBLY INSTRUCTIONS

CLEANLINESS

These chips should be handled in a clean environment.

STATIC SENSITIVITY

These Devices are considered ESD Class 1A, HBM. Proper ESD techniques should be used when handling these devices.

GENERAL HANDLING

The protective polymer coating on the active areas of the die provides scratch and impact protection, particularly for the metal air bridge, which contacts the diode's anode. Die should primarily be handled with vacuum pickup tools, or alternatively with plastic tweezers.

ASSEMBLY TECHNIQUES

The MA4AGSW4, AlGaAs device is designed to be mounted with electrically conductive silver epoxy or with a low temperature solder perform, which does not have a rich tin content.

SOLDER DIE ATTACH

Only solders which do not scavenge gold, such as 80/20, Au/Sn or Indalloy #2 is recommended. Do not expose die to temperatures greater than 300°C for more than 10 seconds.

ELECTRICAL CONDUCTIVE EPOXY DIE ATTACH

Use a controlled thickness of approximately 2 mils for best electrical conductivity and lowest thermal resistance. Cure epoxy per manufacturer's schedule. Typically 150°C for 1 hour.

RIBBON/WIRE BONDING

Thermo-compression wedge or ball bonding may be used to attach ribbons or wire to the gold bonding pads. A 1/4 x 3 mil gold ribbon is recommended on all RF ports and should be kept as short as possible for the lowest inductance and best microwave performance. For more detailed handling and assembly instructions, see [Application Note M541](#), "Bonding and Handling Procedures for Chip Diode Devices" at www.macomtech.com.

Ordering Information

Part Number	Package
MA4AGSW4	Waffle Pack



Компания «ЭлектроПласт» предлагает заключение долгосрочных отношений при поставках импортных электронных компонентов на взаимовыгодных условиях!

Наши преимущества:

- Оперативные поставки широкого спектра электронных компонентов отечественного и импортного производства напрямую от производителей и с крупнейших мировых складов;
- Поставка более 17-ти миллионов наименований электронных компонентов;
- Поставка сложных, дефицитных, либо снятых с производства позиций;
- Оперативные сроки поставки под заказ (от 5 рабочих дней);
- Экспресс доставка в любую точку России;
- Техническая поддержка проекта, помощь в подборе аналогов, поставка прототипов;
- Система менеджмента качества сертифицирована по Международному стандарту ISO 9001;
- Лицензия ФСБ на осуществление работ с использованием сведений, составляющих государственную тайну;
- Поставка специализированных компонентов (Xilinx, Altera, Analog Devices, Intersil, Interpoint, Microsemi, Aeroflex, Peregrine, Syfer, Eurofarad, Texas Instrument, Miteq, Cobham, E2V, MA-COM, Hittite, Mini-Circuits, General Dynamics и др.);

Помимо этого, одним из направлений компании «ЭлектроПласт» является направление «Источники питания». Мы предлагаем Вам помощь Конструкторского отдела:

- Подбор оптимального решения, техническое обоснование при выборе компонента;
- Подбор аналогов;
- Консультации по применению компонента;
- Поставка образцов и прототипов;
- Техническая поддержка проекта;
- Защита от снятия компонента с производства.



Как с нами связаться

Телефон: 8 (812) 309 58 32 (многоканальный)

Факс: 8 (812) 320-02-42

Электронная почта: org@eplast1.ru

Адрес: 198099, г. Санкт-Петербург, ул. Калинина, дом 2, корпус 4, литера А.