



Ordering a market-ready enclosure® is made fast and affordable with our complete in-house capabilities. New Age provides machined openings to fit your PCB, pad printing for your graphics, custom enclosures, custom colors, final assembly, testing and fulfillment services to save you additional time and money. Ask your representative for a free quote today 805-595-1310.

Fast and Affordable Customization

**CNC Modifications
Pad Printing
Colored Resins
EMI/RF Shielding
Custom Enclosure
Assembly & Testing**



ISO quality
off-the-shelf
to market-ready®

NEW AGE ENCLOSURES

www.NewAgeEnclosures.com

4330 Santa Fe Road • San Luis Obispo, CA 93401 • T 805.595.1310 • F 805.595.1024

NOTES: UNLESS OTHERWISE SPECIFIED

1. CORNERS DRAWN SHARP TO BE R.005 MAXIMUM.
2. EXTERIOR SURFACE TEXTURE TO BE LIGHT EDM FINISH. EQUIVELANT TO MT-11010.
3. INTERIOR SURFACE TEXTURE TO BE: NONE.
4. ALL INSIDE RADII .010R. ALL OUTSIDE RADII .020R MAX, UNLESS OTHERWISE SPECIFIED.
5. ALL EXTERNAL DIMENSIONS AFFECTED BY THE DRAFT APPLY AT THE LARGE END OF THE FEATURE, AND ALL INTERNAL FEATURES AFFECTED BY THE DRAFT APPLY AT THE SMALL END OF THE FEATURE UNLESS OTHERWISE SPECIFIED.
6. 1 DEGREE DRAFT IN THE DIRECTION OF PULL IS PERMISSIBLE UNLESS OTHERWISE SPECIFIED.
7. THIS ENCLOSURE IS A PRESS FIT ASSEMBLY. FOR PERMANENT CLOSURE: A DROP OF ADHESIVE OR ULTRASONIC WELDING IS REQUIRED.
8. MATERIAL / COLOR: ABS PLASTIC IS STANDARD IN BLACK OR WHITE. CUSTOM MATERIALS AND COLORS ARE AVAILABLE UPON REQUEST FOR QUOTE.
9. PCB SIZES ARE RECOMMENDATIONS ONLY. FINAL SIZES AND VERIFICATION OF IT'S FIT ARE THE SOLE RESPONSIBILITY OF OEM.

R E V I S I O N					
REV.	DRAWN BY	ECO No	DESCRIPTION	DATE	APPROVED
A	M BOYER	DR XXX	PRELIMINARY RELEASE	03-Oct-09	D.C.
B	M BOYER	N/A	CHANGE EXTERIOR	24-Oct-09	D.C.
C	M BOYER	N/A	RECESS AND CHAMFER ADJUSTMENTS	27-Oct-09	D.C.
D	M BOYER	N/A	REMOVE LABEL RECESS	30-Oct-09	D.C.
1.0	M BOYER	N/A	UPDATE TO AS-BUILT AND RELEASE	26-Mar-10	D.C.
2.0	M BOYER	2510	ADJUST POST HEIGHT	07-Jul-10	

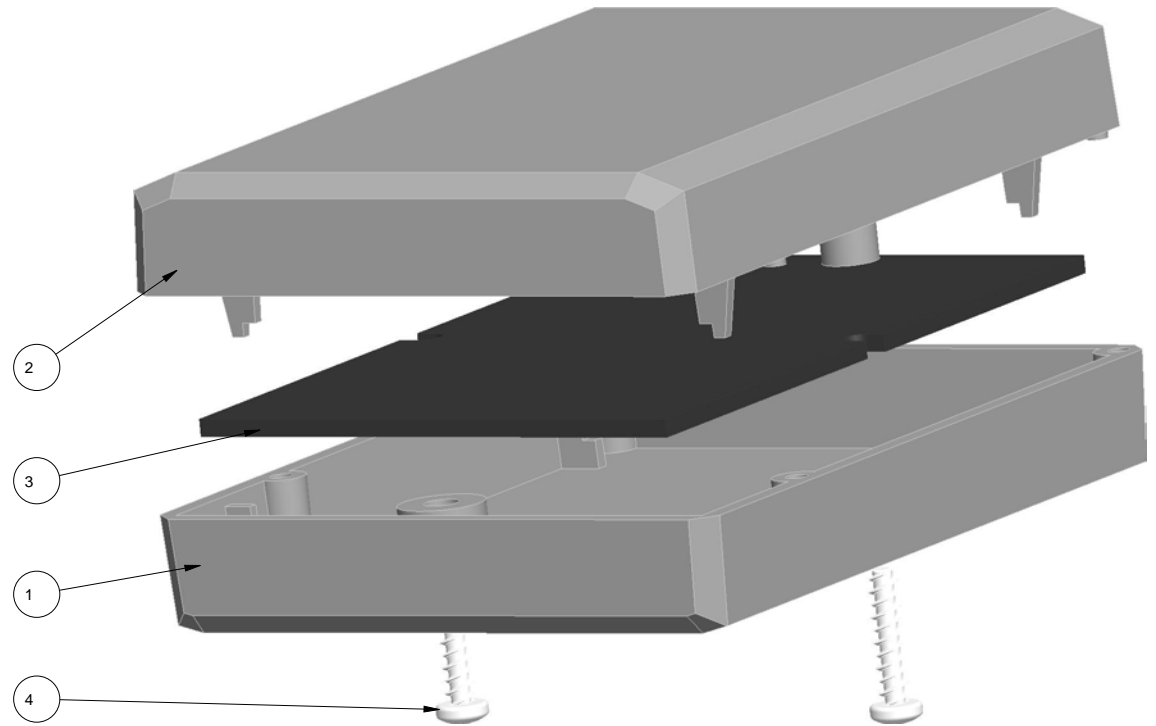

SCALE 1.500

ITEM	FILE NAME	DESCRIPTION	MATERIAL	COLOR	QTY.
4	SCREW_HILO-NO4X500	#4 HiLo x .500" SCREW	#4 HiLo x 1/2"	ZINK PLATED	2
3	312208_PCB	312208 PCB - REFERENCE	.062" THICK	CUSTOMER SUPPLIED	1
2	312208_MALE	312208 MALE - STANDARD	ABS	BLACK-WHITE	1
1	312208_FEMALE	312208 FEMALE - STANDARD	ABS	BLACK-WHITE	1

BILL OF MATERIALS

<p>THIRD ANGLE PROJECTION</p> <p>DO NOT SCALE DRAWING</p>	<p>TOLERANCES: UNLESS OTHERWISE SPECIFIED DIMENSIONS ARE IN U.S. INCHES:</p> <p>X.XX = .015 X.XXXX = .001 X.XXX = .010 X.X° = 1°</p>		<p>NEW AGE ENCLOSURES</p> <p>4330 Santa Fe Road San Luis Obispo, CA. 93401 ph. (805) 595-1310 fax (805) 595-1024 www.newageenclosures.com</p>	
	<p>Customer's Part No: 312208</p>		<p>STANDARD - PROJECT BOX SXX-312208 ASSEMBLY</p>	
<p>APPROVAL</p> <p>CHECK</p> <p>ENG.</p> <p>SCALE</p> <p>DRAWN BY</p> <p>M BOYER</p>	<p>BY</p> <p>DATE</p> <p>03-Oct-09</p>	<p>SIZE</p> <p>A</p>	<p>DRAWING NAME</p> <p>312208_R2_0</p>	<p>SHEET</p> <p>1 OF 6</p>
				<p>REV.DOC</p> <p>2.0</p>

NOTICE: THE INFORMATION AND DATA CONTAINED HEREIN IS CONSIDERED PROPRIETARY TO ALLTEC INTEGRATED MFG INC & SHALL REMAIN THE EXCLUSIVE PROPERTY OF ALLTEC INTEGRATED MFG INC. THE HOLDER WILL ASSUME CUSTODY AND CONTROL THAT THIS DOCUMENT WILL NOT BE COPIED, REPRODUCED, OR DISCLOSED WITHOUT THE EXPRESS WRITTEN CONSENT OF ALLTEC INTEGRATED MFG INC. POSSESSION OF THIS DOCUMENT DOES NOT CONSTITUTE A GRANT TO MANUFACTURE ANY ITEMS.
© 2010

312208 ASSEMBLY

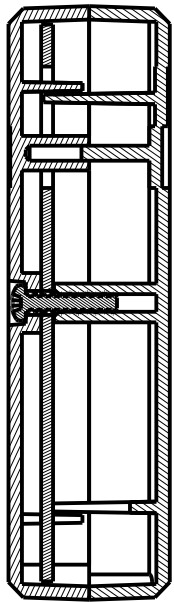
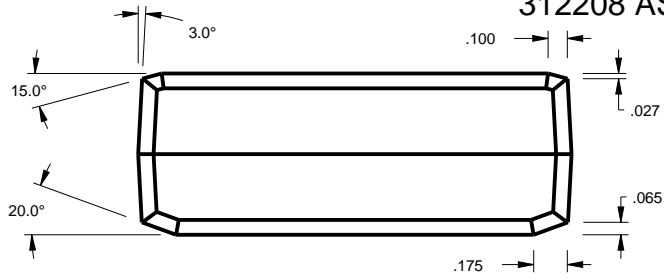

SECTION D-D

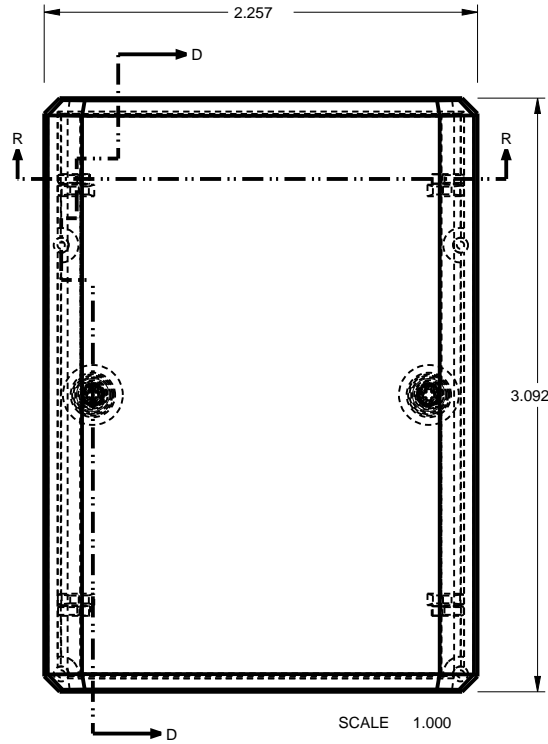

SCALE 1.000

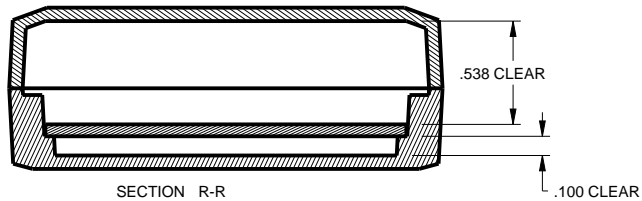
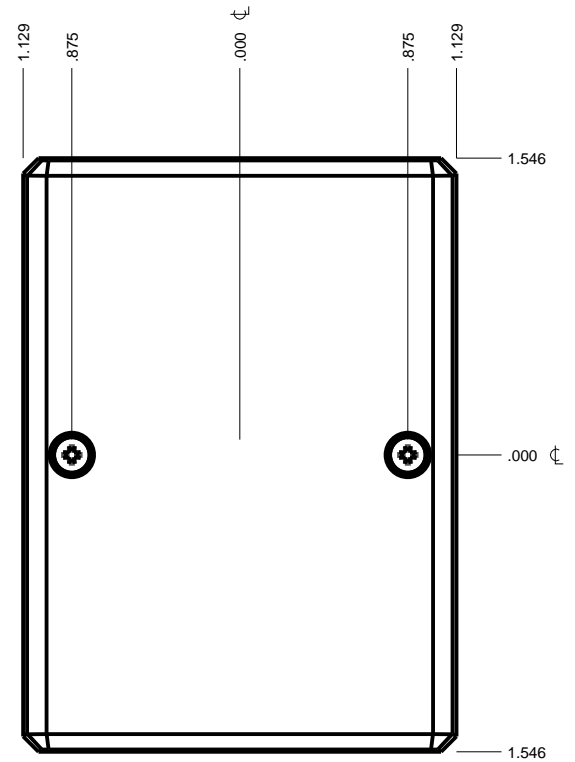
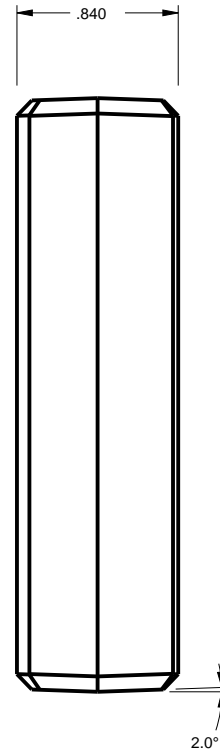

SECTION R-R

TOLERANCES: UNLESS OTHERWISE SPECIFIED DIMENSIONS ARE IN U.S. INCHES:	
X.XX = .015	X.XXXX = .001
X.XXX = .010	X.X° = 1°
NEW AGE ENCLOSURES	
Customer's Part No: 312208	
APPROVAL	BY DATE
CHECK	
ENG.	
SCALE	
DRAWN BY	03-Oct-09
M BOYER	

NEW AGE ENCLOSURES
 4330 Santa Fe Road San Luis Obispo, CA. 93401
 ph. (805) 595-1310 fax (805) 595-1024
www.newageenclosures.com

**STANDARD - PROJECT BOX
 SXX-312208 ASSEMBLY**

SIZE	DRAWING NAME	SHEET	REV.DOC
A	312208_R2_0	2 OF 6	2.0

312208 FEMALE

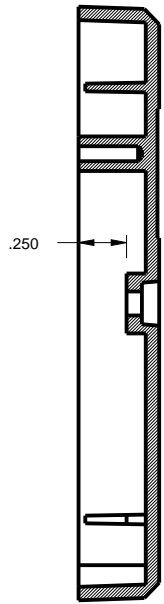
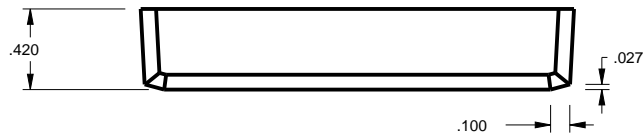

SECTION T-T

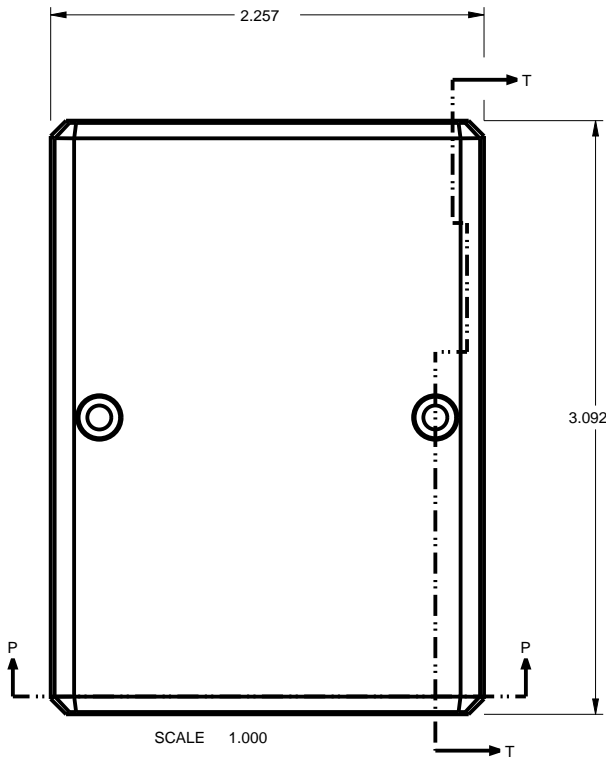

SCALE 1.000

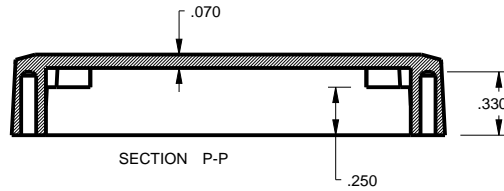
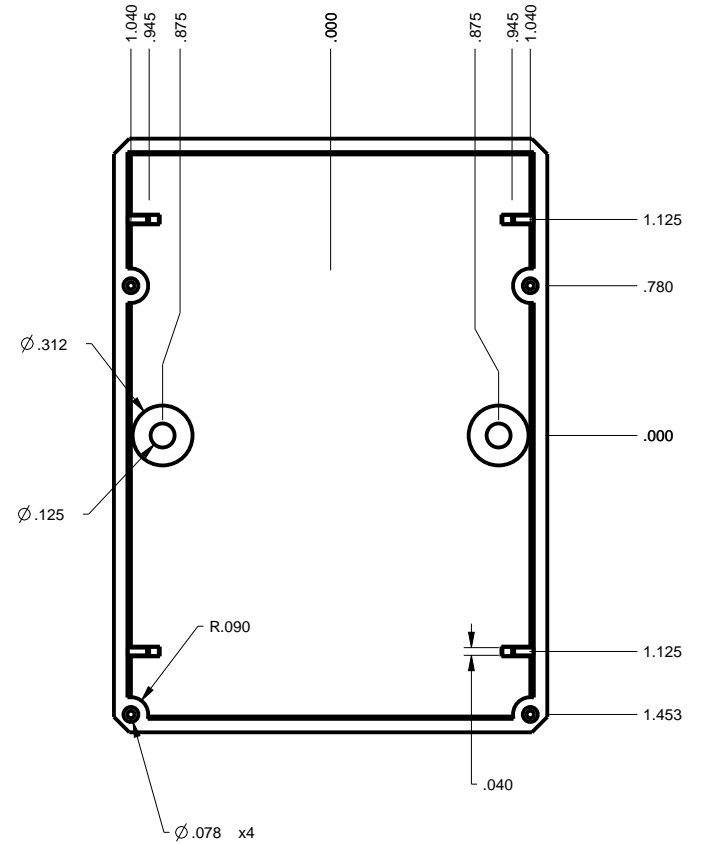
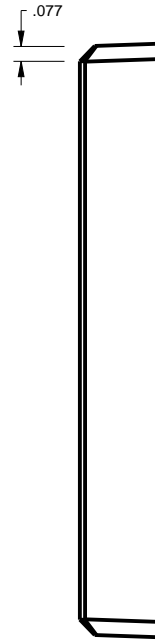

SECTION P-P

TOLERANCES: UNLESS OTHERWISE SPECIFIED DIMENSIONS ARE IN U.S. INCHES:	
X.XX = .015	X.XXXX = .001
X.XXX = .010	X.X° = 1°
NEW AGE ENCLOSURES	
Customer's Part No: 312208	
APPROVAL	BY DATE
CHECK	
ENG.	
SCALE	
DRAWN BY	03-Oct-09
M BOYER	

NEW AGE ENCLOSURES
 4330 Santa Fe Road San Luis Obispo, CA. 93401
 ph. (805) 595-1310 fax (805) 595-1024
www.newageenclosures.com

STANDARD - PROJECT BOX SXX-312208 ASSEMBLY	
SIZE	DRAWING NAME
A	312208_R2_0
SHEET	REV.DOC
3 OF 6	2.0

312208 MALE

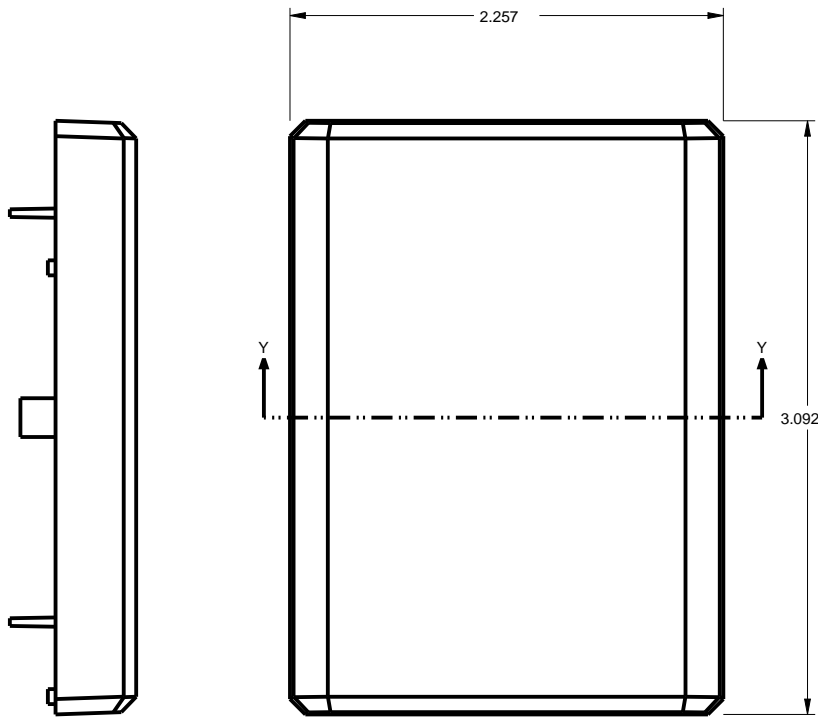
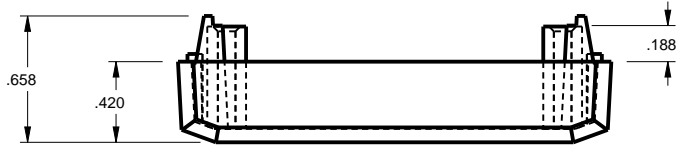

SCALE 1.000

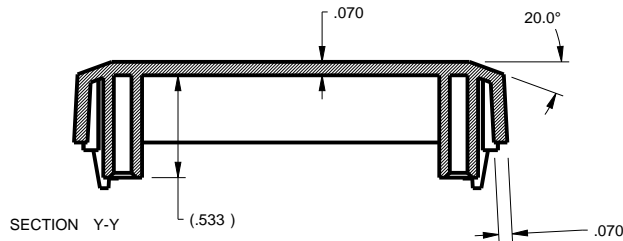
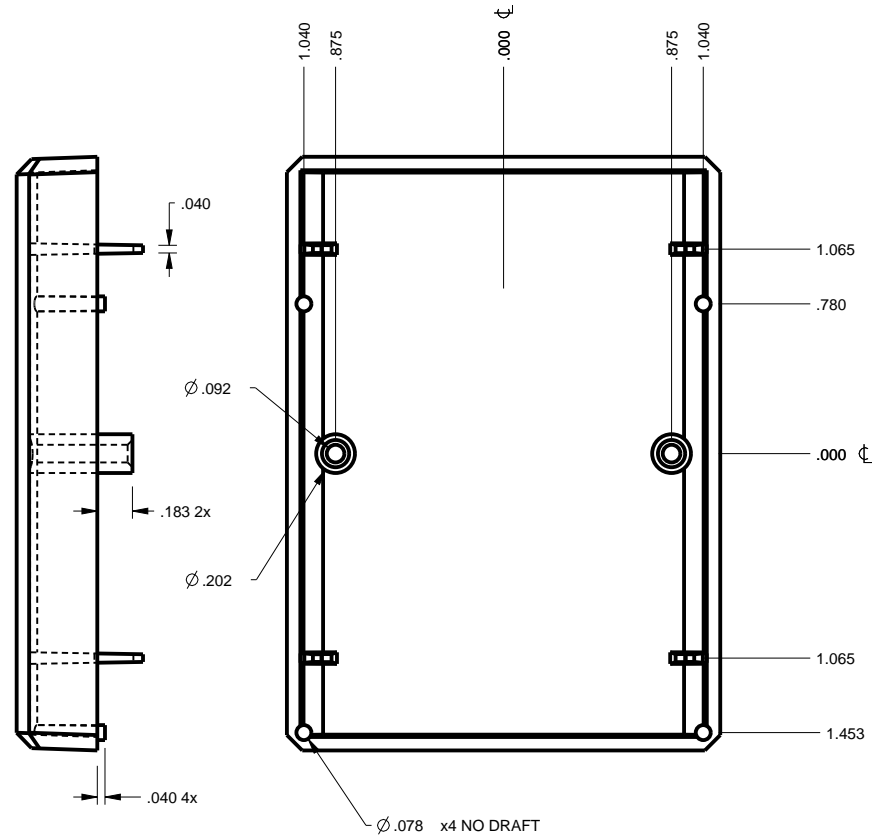

TOLERANCES: UNLESS OTHERWISE SPECIFIED
DIMENSIONS ARE IN U.S. INCHES:
X.XX = .015 X.XXXX = .001
X.XXX = .010 X.X° = 1°

NEW AGE ENCLOSURES
Customer's Part No: 312208

APPROVAL	BY	DATE
CHECK		
ENG.		
SCALE		
DRAWN BY	03-Oct-09	
M BOYER		

NEW AGE ENCLOSURES
4330 Santa Fe Road San Luis Obispo, CA. 93401
ph. (805) 595-1310 fax (805) 595-1024
www.newageenclosures.com

**STANDARD - PROJECT BOX
SXX-312208 ASSEMBLY**

SIZE	DRAWING NAME	SHEET	REV.DOC
A	312208_R2_0	4 OF 6	2.0

312208 PCB

PCB SIZES ARE RECOMMENDATIONS ONLY. FINAL SIZES AND VERIFICATION OF IT'S FIT ARE THE SOLE RESPONSIBILITY OF THE OEM.

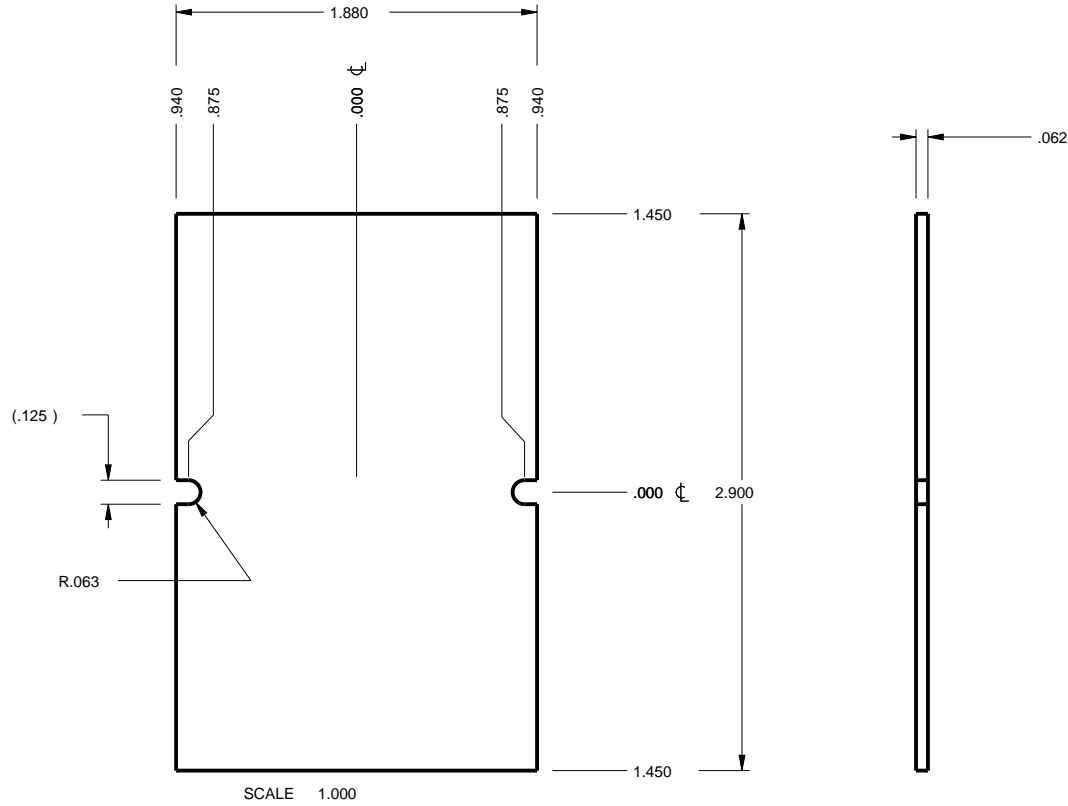

TOLERANCES: UNLESS OTHERWISE SPECIFIED DIMENSIONS ARE IN U.S. INCHES: X.XX = .015 X.XXXX = .001 X.XXX = .010 X.X° = 1°		NEW AGE ENCLOSURES 4330 Santa Fe Road San Luis Obispo, CA. 93401 ph. (805) 595-1310 fax (805) 595-1024 www.newageenclosures.com				
Customer's Part No: 312208						
APPROVAL	BY	DATE	STANDARD - PROJECT BOX SXX-312208 ASSEMBLY			
CHECK						
ENG.						
SCALE						
DRAWN BY			SIZE	DRAWING NAME	SHEET	REV.DOC
M BOYER		03-Oct-09	A	312208_R2_0	5 OF 6	2.0

2nd OPERATION DETAILS

NEW AGE ENCLOSURES DELIVERS YOUR ENCLOSURE MARKET-READY WITH IN-HOUSE
CNC MACHINING, PAD PRINTING, ASSEMBLY, AND FULFILLMENT.
ALL SURFACES AND AREAS ARE AVAILABLE FOR CNC ALTERATION BY NEW AGE ENCLOSURES
CALL (805) 595-1310 FOR PRICING AND SCHEDULE.
THE INSIDE RADIUS OF ANY MACHINED FEATURES SHOULD BE NO SMALLER THAN .031"

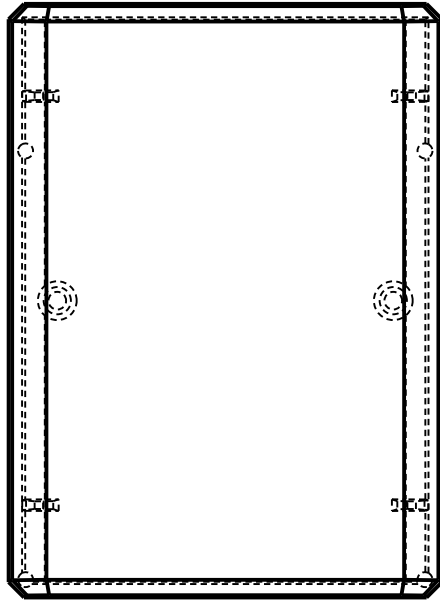

312208 MALE
SCALE 1.000

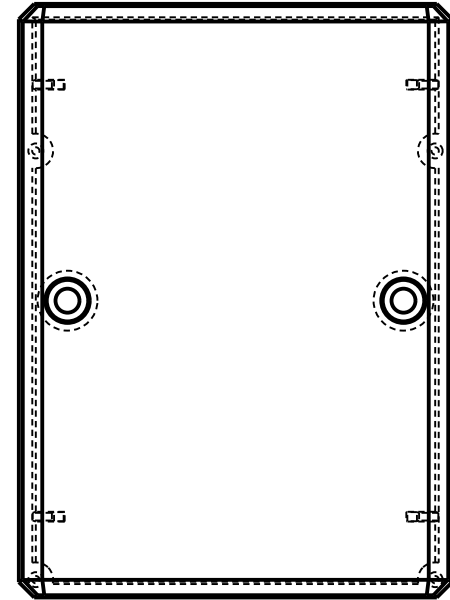
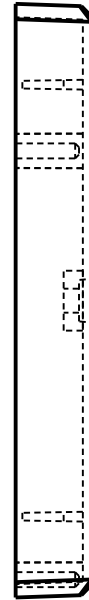
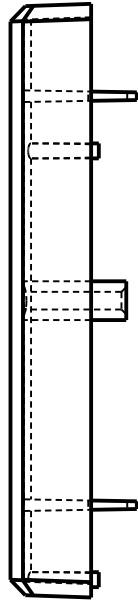

312208 FEMALE
SCALE 1.000

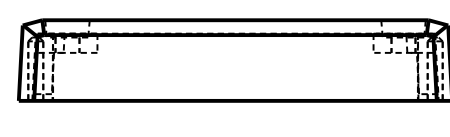
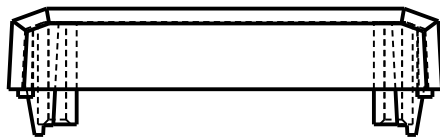

SXX-312208-XXX MALE - ABS, BLACK

STEP NO	DESCRIPTION	CUTTER	FIXTURE	ORIENTATION	PROGRAM
1	-	T2 = .062" EM	-	-	-
2	-	T2 = .062" EM	-	-	-
3	-	T2 = .062" EM	-	-	-

SXX-312208-XXX FEMALE - ABS, BLACK

STEP NO	DESCRIPTION	CUTTER	FIXTURE	ORIENTATION	PROGRAM
4	-	T2 = .062" EM	-	-	-
5	-	T2 = .062" EM	-	-	-
6	-	T2 = .062" EM	-	-	-

TOLERANCES: UNLESS OTHERWISE SPECIFIED
DIMENSIONS ARE IN U.S. INCHES:
X.XX = .015 X.XXXX = .001
X.XXX = .010 X.X° = 1°

NEW AGE ENCLOSURES

Customer's Part No: 312208

APPROVAL	BY	DATE
CHECK		
ENG.		
SCALE		
DRAWN BY	03-Oct-09	
M BOYER		

NEW AGE ENCLOSURES

4330 Santa Fe Road San Luis Obispo, CA. 93401
ph. (805) 595-1310 fax (805) 595-1024

www.newageenclosures.com

STANDARD - PROJECT BOX SXX-312208 ASSEMBLY

SIZE	DRAWING NAME	SHEET	REV.DOC
A	312208_R2_0	6 OF 6	2.0

Mouser Electronics

Authorized Distributor

Click to View Pricing, Inventory, Delivery & Lifecycle Information:

[New Age Enclosures:](#)

[S1A-312208](#) [S3A-312208](#)



Компания «ЭлектроПласт» предлагает заключение долгосрочных отношений при поставках импортных электронных компонентов на взаимовыгодных условиях!

Наши преимущества:

- Оперативные поставки широкого спектра электронных компонентов отечественного и импортного производства напрямую от производителей и с крупнейших мировых складов;
- Поставка более 17-ти миллионов наименований электронных компонентов;
- Поставка сложных, дефицитных, либо снятых с производства позиций;
- Оперативные сроки поставки под заказ (от 5 рабочих дней);
- Экспресс доставка в любую точку России;
- Техническая поддержка проекта, помощь в подборе аналогов, поставка прототипов;
- Система менеджмента качества сертифицирована по Международному стандарту ISO 9001;
- Лицензия ФСБ на осуществление работ с использованием сведений, составляющих государственную тайну;
- Поставка специализированных компонентов (Xilinx, Altera, Analog Devices, Intersil, Interpoint, Microsemi, Aeroflex, Peregrine, Syfer, Eurofarad, Texas Instrument, Miteq, Cobham, E2V, MA-COM, Hittite, Mini-Circuits, General Dynamics и др.);

Помимо этого, одним из направлений компании «ЭлектроПласт» является направление «Источники питания». Мы предлагаем Вам помощь Конструкторского отдела:

- Подбор оптимального решения, техническое обоснование при выборе компонента;
- Подбор аналогов;
- Консультации по применению компонента;
- Поставка образцов и прототипов;
- Техническая поддержка проекта;
- Защита от снятия компонента с производства.



Как с нами связаться

Телефон: 8 (812) 309 58 32 (многоканальный)

Факс: 8 (812) 320-02-42

Электронная почта: org@eplast1.ru

Адрес: 198099, г. Санкт-Петербург, ул. Калинина, дом 2, корпус 4, литера А.