

16Km Radio Telemetry Transceiver

Features

- FSK & Spread Spectrum LoRa
- Upto 16km range line of sight
- 2 x Closed Contact Input
- 2 x Relay Switch Output
- All Signals 'Acknowledged'
- 'Watchdog' Feature
- Built in range test Mode
- Many to Many Operation
- 12-32Vdc Supply
- LED Bar graph Signal indicator
- Easy 'Plug and Play' Installation
- Add-on Input/ Output channels
- 868MHz Version CE compliant
- 915MHz FCC Compliant

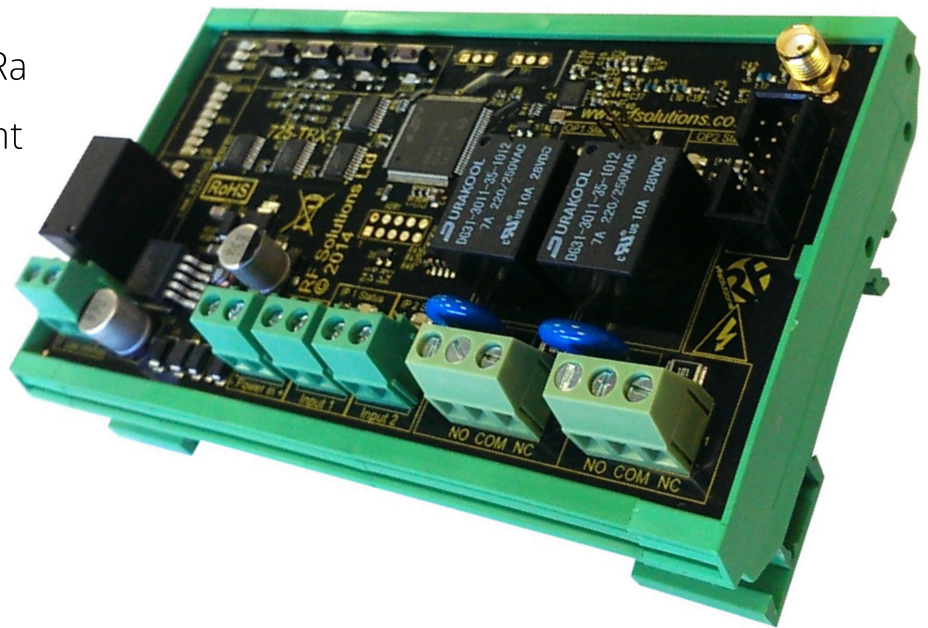

Applications

- Industrial Telemetry
- Remote Monitoring & Control
- Reliable Remote Switch

The 725TRX telemetry system provides bi-directional, transceiver, remote switching. Each Module has two Switch inputs and two Relay changeover contact outputs. When two or more modules are paired together the relay outputs will follow the state changes of the other modules' Inputs.

Additional input / output modules can be connected to provide extra inputs/outputs. The system inputs / outputs can be used in various ways which are shown later in the datasheet.

All signals are Acknowledged and a watchdog feature means that when an input is activated, the status of its remote counterpart is assured. This is automatic, allowing the user to simply connect to the screw terminals and achieve a reliable Telemetry link

Products Overview



725TRX Transceiver

- Range up to 16Km line of sight.
- Self Contained Telemetry Transceiver
- 2 No volt inputs
- 2 Relay Outputs
- 1 Relay Watchdog output for Failsafe Operation
- All Connections via screw terminal
- Supply Voltage 12-32Vdc
- Supplied with antenna

Part Number	Description	Range*
725-TRX8-1K	868MHz Transceiver +13dBm	1km
725-TRX8-16	868MHz Transceiver +20dBm	16km
725-TRX9-1K	915MHz Transceiver +13dBm	1km
725-TRX9-16K	915MHz Transceiver +20dBm	16km

* Range is quoted optimum LOS.

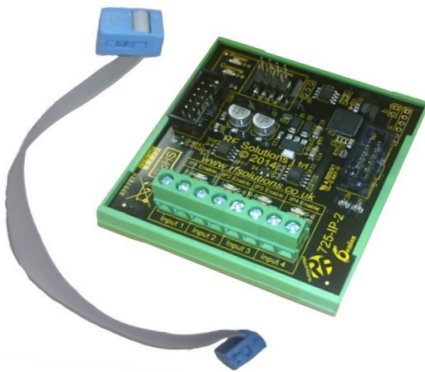

Additional input board 4 Closed contact Inputs

- Connects Directly to 725TRX
- Connecting ribbon cable supplied
- Up to 16 725-IP may be Daisy Chained to 725TRX
- Provides a simple extension to the number of Inputs

Part Number	Description
725-IP	4 input Add-on Module

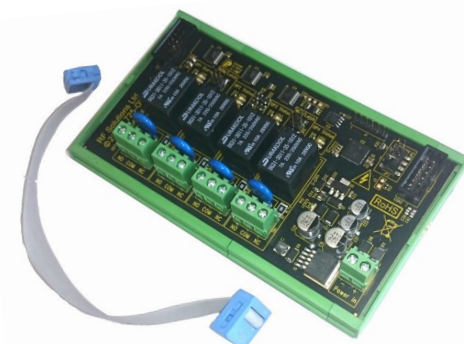

Additional Output board

- 4 Changeover Relay Outputs
- Connecting ribbon cable supplied
- Up to four 725-OP can be Daisy Chained without VCC linked.
- Up to 16 725-OP can be Daisy Chained with VCC linked.
- Provides a simple extension to the number of Inputs

Part Number	Description
725-OP	4 Output Add-on Module

725TRX Overview

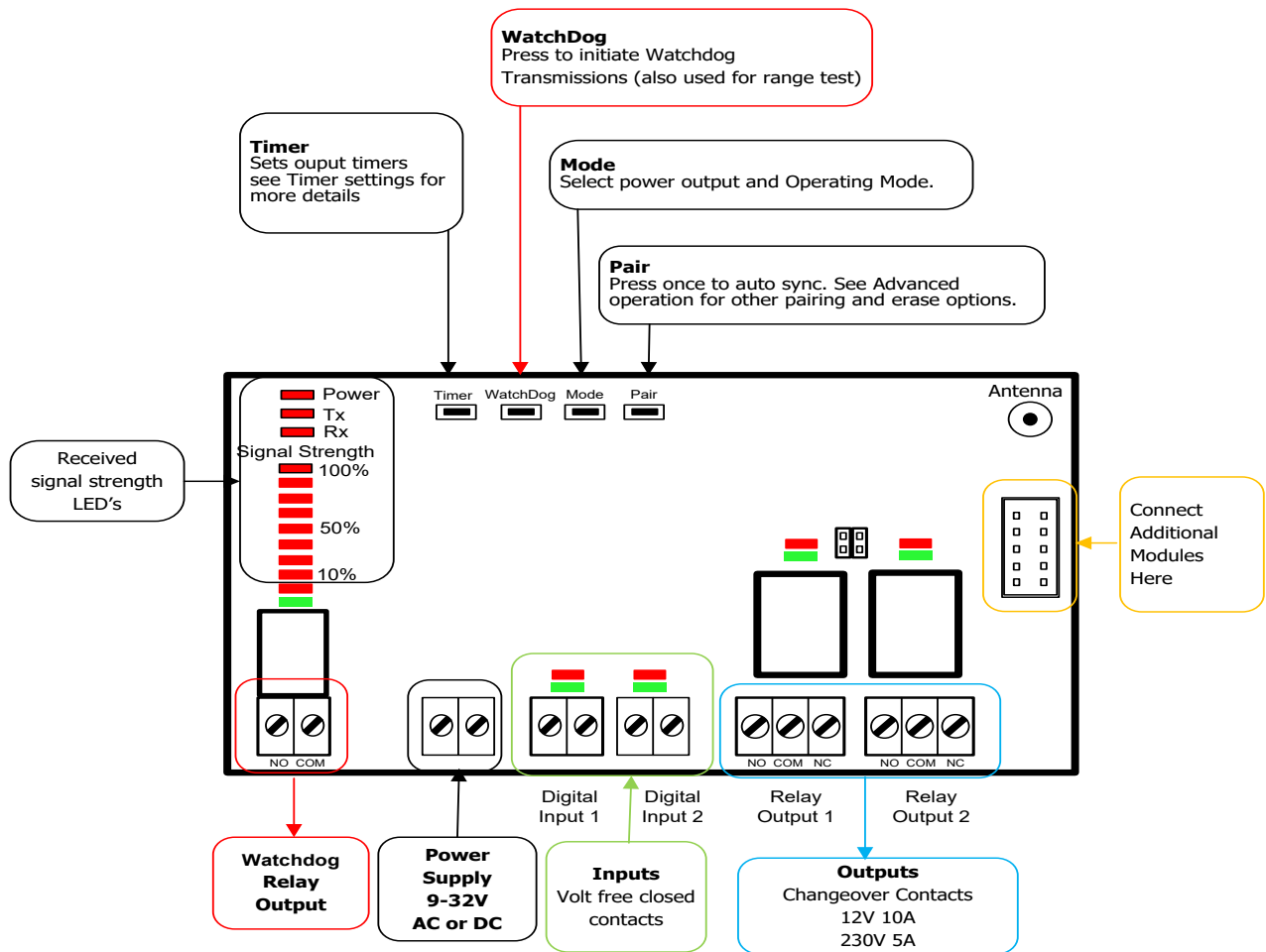

Overview of Features

725TRX has many 'optional' features. These are summarised below and explained in detail later in this document.

Auto or Manual Pairing: Modules can be auto paired together in banks or any individual input can be paired to any individual output(s).

WATCHDOG : This is a relay contact which is held 'ON' as long as the Auto TX signal is received.

RF Mode : Time of operation can be traded with system range. For standard FM operation the outputs operate within 30 milliseconds, when LORA (Long Range) is enabled the time delay can be a couple of seconds. (16K version only)

TIMER: The outputs can be set to Momentary/Latching /Timed

Additional Modules: Additional Input and Output modules or a combination of both can be connect (max 16 of each)

Please note: when using more than 2 output boards VCC must be connected to the 725-OP boards.

Creating a Telemetry System using Two 725 TRX's

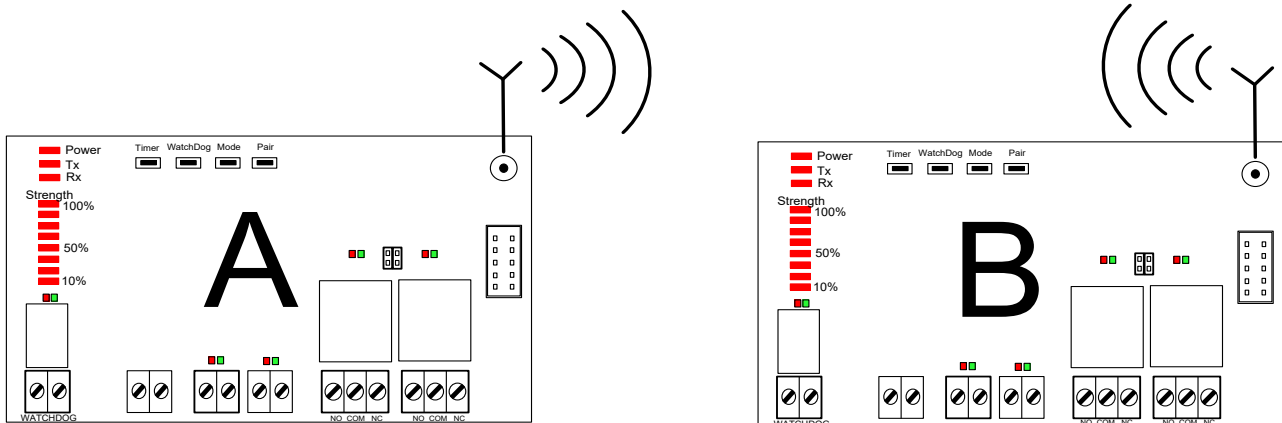

Follow these Steps

1. **Connect to screw Terminal Inputs.**
2. **Connect to screw Terminal Outputs.**
3. **Pair Together 725TRX Modules A and B.**
4. **Set Output Jumper Links (Momentary or Latching).**
5. **Optional configuration: Auto TX / TIMERS / WATCHDOG / MODE.**

Pairing

Factory Default Status

In Factory default Input/Output LEDs flash Red/Green alternately

To AUTO-PAIR A to B

1. Press and release the PAIR button on the 725TRX B.
2. The pair and all relay output LED's will flash on 725TRX B
3. Activate ANY input on 725TRX A.
4. All flashing LEDs on 725TRX B relays will go out. The PAIR LED will flash quickly for 2 seconds .
5. Pairing Complete

To PAIR A Input 1 to B Output 2

1. Press and release the PAIR button on the 725TRX B to enter pair mode. Press and release the PAIR button to cycle through LED's until only the LED above Relay 2 is Flashing
2. Activate input 1 on 725TRX A.
3. All flashing LEDs on 725TRX B relays will go out, the PAIR LED will flash quickly for 2 seconds .
4. Pairing Complete

Please Note:

1. Manual pair will not work when auto pair has been used.
2. The max no of pairings is 32, this applies to individual inputs (or buttons on keyfob)
E.g. a single 725-TRX can learn 32 individual 1 button FOBBER Keyfobs , or 8, 4 button FOBBER KEYfobs

Pairing a hand held transmitter

To AUTO-PAIR a hand held transmitter

1. Press and release the PAIR button on the 725TRX.
2. The pair and all relay output LED's will flash on 725TRX.*
3. Activate ANY button on your transmitter.
4. All flashing LEDs on 725TRX relays will go out. The PAIR LED will flash quickly for 2 seconds .
5. Auto-Pair is Complete

Note: *To Auto-Pair an output board you need to press the Pair button again and repeat until the desired 725-OP LEDs are flashing then continue from step 3.

To PAIR a hand held transmitter button to Relay 2.

1. Press and release the PAIR button on the 725TRX to enter pair mode. Press and release the PAIR button to cycle through LED's until only the LED above Relay 2 is Flashing
2. Activate your chosen button on your transmitter.
3. All flashing LEDs on 725TRX relays will go out. The PAIR LED will flash quickly for 2 seconds .
4. Pairing is Complete

Note: *To Pair an output board relay you need to press the Pair button and repeat to cycle through LED's until only the LED above the desired 725-OP relay is flashing then continue from step 2.

Please Note: Manual pair will not work when auto pair has been used.

Erasing

Reset to Factory Default Setting

The 725TRX may be reset to Factory default at any time by pressing the PAIR button for 15 seconds.

Erasing Everything (reset to Factory Default):

1. Apply power
2. Press and hold the PAIR button for 15 seconds, the PAIR LED will flash slow then fast.
3. Release the PAIR button.
4. 725-TRX now reset to Factory Default

ERASE Individual Transmitters:

1. Apply power
2. Press and hold the PAIR button for 10 seconds, the PAIR LED will flash slow as soon as this happens release the PAIR button.
3. Press any button on the transmitter to be erased.
4. The 725-TRX will exit to normal operating mode and the transmitter will be erased.

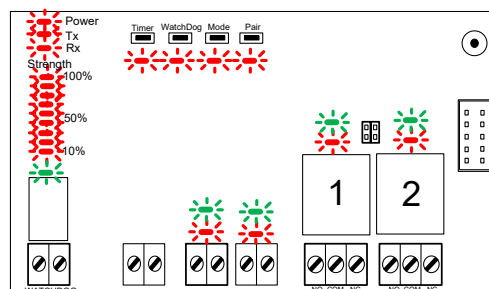

INPUTs Status LEDs

Inputs are activated by a closed contact switch.

When the status of any input is changed 725TRX immediately broadcasts the status (of all inputs).

After receiving the RF transmission, the paired 725TRX(s) respond with an ACKNOWLEDGE RF Signal.

When the ACKNOWLEDGE signal is received by the transmitting 725TRX it will be indicated on the input LED's.

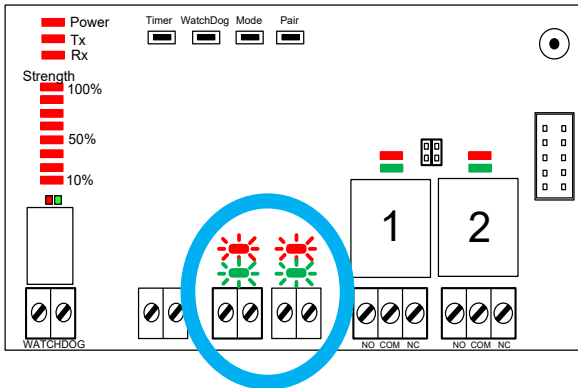

GREEN LED	Status of Input
ON	Input Active / ON
OFF	Input Inactive / OFF

RED LED	Feedback from Receiver
OFF	The paired 725TRX Output is in Sync with this input
ON	No acknowledge from the paired 725TRX
Flashing	Input is not paired with any Receiver output

OUTPUTs Status LEDs

When the receiving 725TRX gets a valid signal from a paired device it will activate an output.

The status of active relays will be displayed on their corresponding LED's.

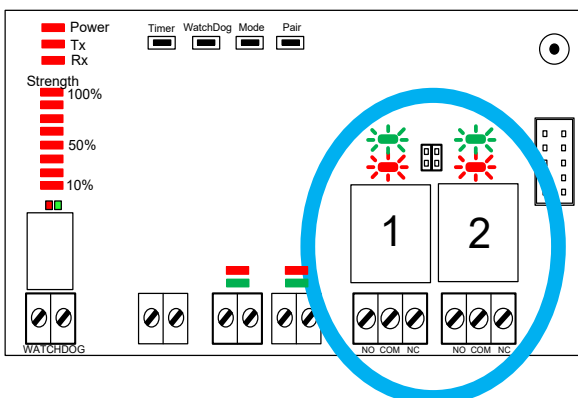

GREEN LED	Status of Output
ON	Relay is Active / ON
OFF	Relay is Inactive / OFF

RED LED	Feedback from Receiver
OFF	The paired 725TRX Output is paired with this output
Flashing	Relay is unpaired with any Receiver output

MOMENTARY/LATCHING setting links

Each Relay Output can be individually preset to Momentary/Latching by fitting or removing the Link Headers

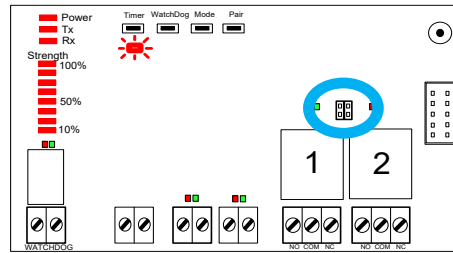

Link fitted	LATCHING	Output changes state on each Transmit signal
Link Removed	MOMENTARY	Output operates for duration of Transmit signal

TIMER (Setting an Output Time Delay)

Setting a Timed Output.

1. Briefly press the TIMER Switch .
2. The TIMER and first relay output LED's will flash.
3. Press the TIMER switch again to scroll through relays until the chosen relay LED is flashing.
4. Wait until the chosen relay LED is on constantly.
5. Now Each press of the timer button will increase the timer delay in line with the TIMER OUTPUT Table Displayed on the signal strength LED's.
6. When you have selected the required delay, wait 3 seconds.
7. The Red TIMER LED will Stop flashing to show that the setting is saved

Note: Settings are saved even after power is removed.

Note: When zero LED's are lit the relays will operate as per the Momentary/Latching links.

LED	Timer Output
8	60 min
7	30 min
6	10 min
5	1 min
4	30 sec
3	10 sec
2	5 sec
1	1/2 sec
0	Mom

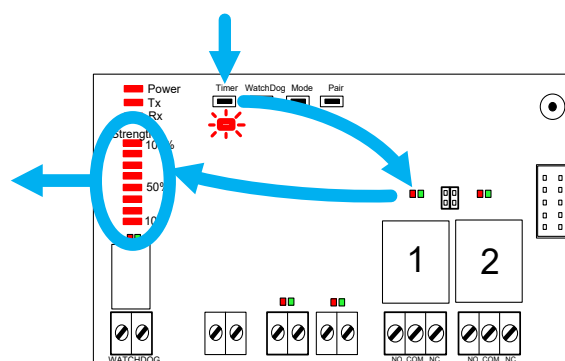

Erase ALL Timers:

1. Press and hold the TIMER button for 10 seconds,
2. Whilst held the TIMER LED will turn on and then flash fast.
3. When the LED flashes fast release the timer button the erase is complete

Note: When setting a Time Delay;

If the Jumper Link is Removed the Time delay will restart on each transmission regardless of output Status.

If the Jumper Link is Fitted, the Time delay output Will Latch OFF / ON Timed with each transmission.

Transmitting a Watchdog Signal

When enabled the 725TRX automatically transmits an intermittent 'Watchdog' signal according to the AUTO TX Interval Table. The Receiving 725TRX holds the Watchdog Relay ON as long as signal is received.

LED	Auto Tx Interval
8	120 min
7	60 min
6	20 min
5	10 min
4	2 min
3	65 sec
2	45 sec
1	25 sec

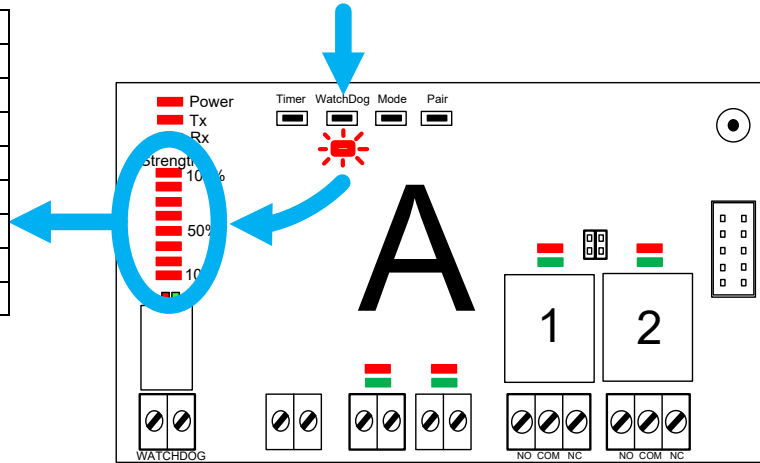

Receiving a Watchdog Signal

The paired 725TRX Receiver will hold its Watchdog Relay contacts ON as long as a AUTO TX signal is received. If an AUTOTX signal is not received within the Watchdog Timeout period then the Watchdog relay will drop out.

Note: We recommend that the receiving 725 allows for at least 3 Auto TX time periods

LED	Watchdog Timeout
8	360 min
7	180 min
6	60 min
5	30 min
4	6 min
3	195 sec
2	135 sec
1	80 sec

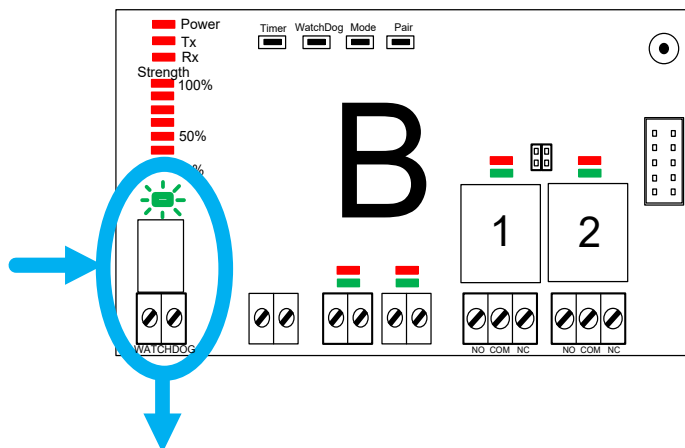

Note: The 725-TRX will need to be paired in both directions for both watchdog relays to operate. A 725-TRX can only receive a watchdog signal when paired as a receiver.

Note: when using Lora and Watchdog. Ensure that the Auto Tx Signal interval allows enough time for the Lora signal to transmit!

725 Series



RF Mode of Operation

The 725 Transceivers can be configured to operate as standard FSK or LoRA Modes.

FSK = (FM) fixed frequency Carrier Frequency

LoRA- Long Range Spread Spectrum Frequency Hopping Protocol.

FSK: provides a fast Time of operation and is compatible with all other RF Solutions products at this frequency.

LoRA can be set to one of several modes of operation where the time of operation is extended but so also is the range.

LED	Summary	Typical RF Transmit Packet Time
8	LORA	1.28 Seconds
7	LORA	640 mSecs
6	LORA	320 mSecs
5	LORA	160 mSecs
4	LORA	80 mSecs
3	LORA	40 mSecs
2	LORA	20 mSecs
1	FSK	20 mSecs

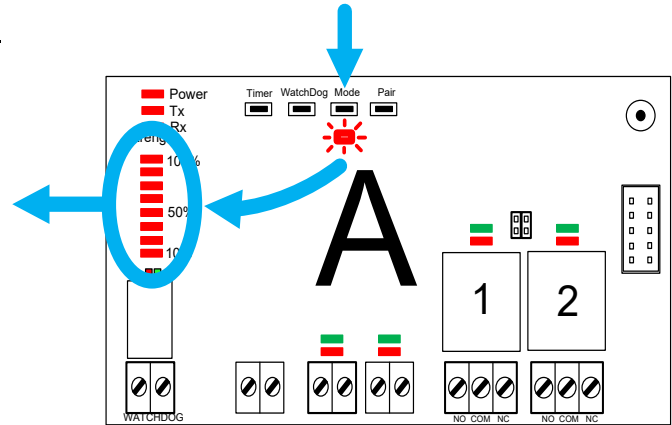

Note: 725TRX '1K' versions can only operate in mode 1!

To Set the Mode of operation

1. Press the MODE button momentarily the MODE LED will flash.
2. Repeat press the MODE button until the chosen interval is selected indicated by the Sig Strength LED's

Display Signal Strength

This provides a signal strength / Walk Test

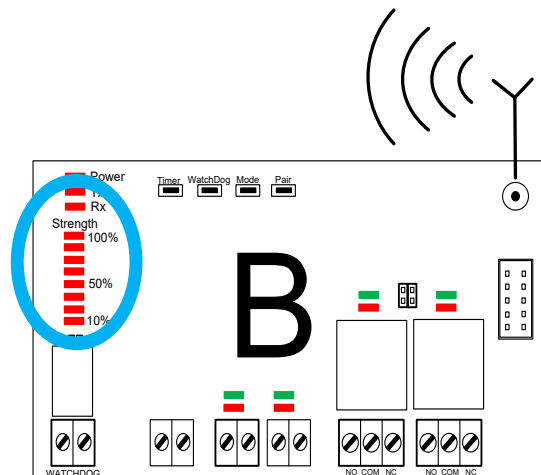
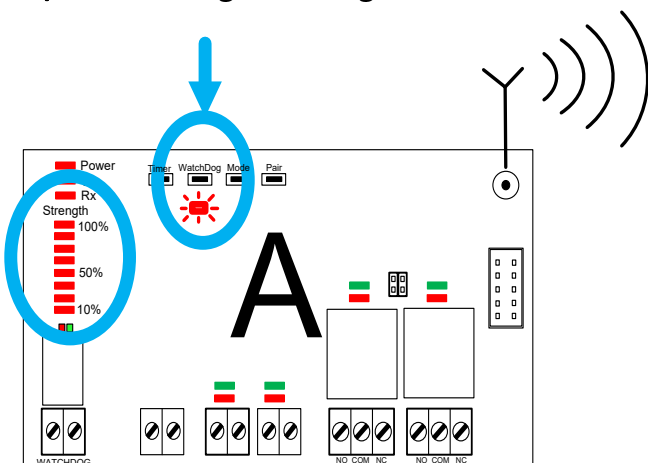

1. Press and hold the WatchDog button on the Transmitter for 5 seconds.
2. 725TRX emits a special transmission every second,
3. Any 725TRX will display the received Beacon on the signal strength LED bar graph.
4. An acknowledge will be sent back to the originating 725TRX by any paired 725TRX which will also display on its signal Strength LED bargraph
5. When activated on a paired transmitter, LEDs 1-8 on both devices will show signal strength - the more LEDs flashing, the better the signal.

NOTES: For reliable communications we recommend 3 or more LED's are illuminated.



Additional Input / Output Modules

Up to 16 Input and 16 Output modules can be added (64 inputs and 64 outputs max).
Cables are supplied to enable the modules to plug and play.
No other configuration is required the add on modules function as an extension of the 725TRX Module

725-IP Additional 4- Inputs Module

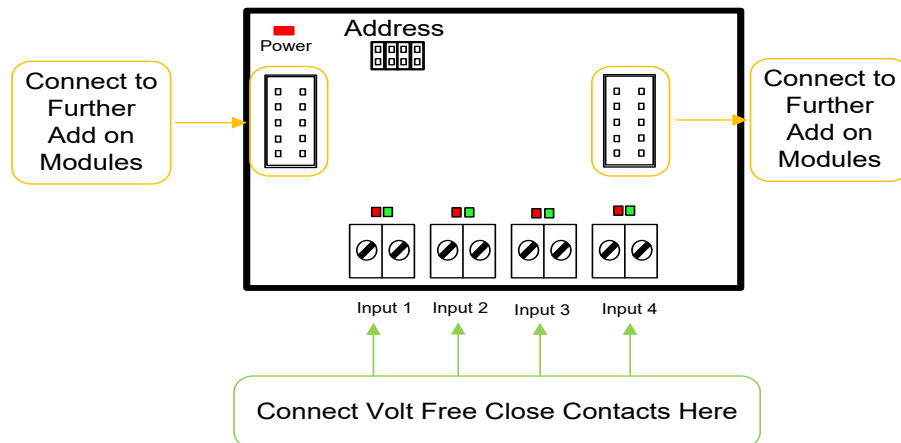

725-OP Additional Outputs Module

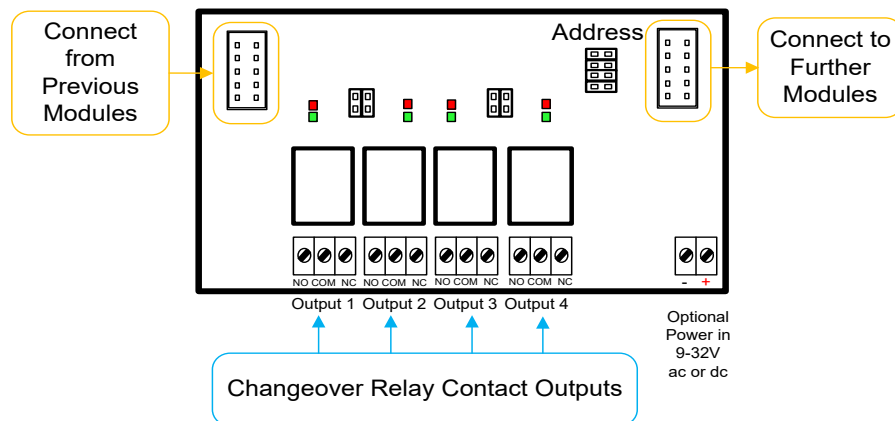

Connecting Add-on Input/Output Modules

Address settings

Each module must have a unique address set by the Address jumpers (it doesn't matter what the address is)

Note: outputs will cycle in address order for pairing, timers and erasing.

Connect to 725TRX

Connect to the 725TRX or previous I/O module using the ribbon cable provided

Note: When connecting more than one 725-OP module the power must be connected directly to the 725-OP module screw terminals

Application Example A to B Telemetry

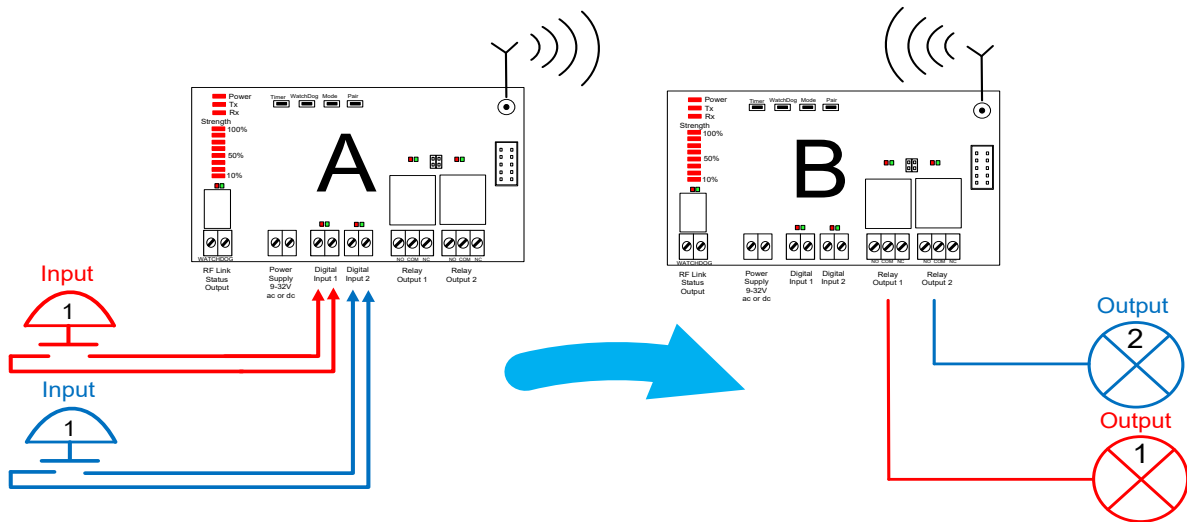

The outputs of 'B' follow the inputs of 'A'

Application Example A to B and B to A Telemetry

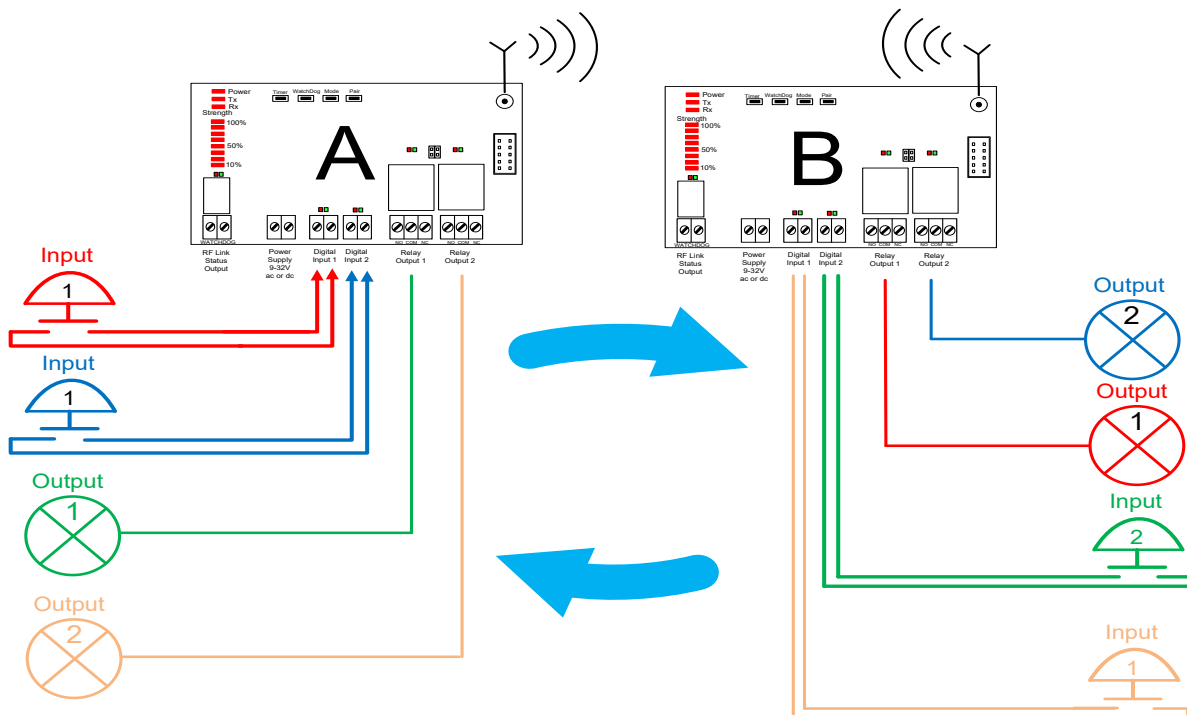

Application Example using Multiple Add-on Modules

In this Below example;

'A' inputs are paired directly with 'B' Outputs

'B' inputs are paired directly with 'A' Outputs

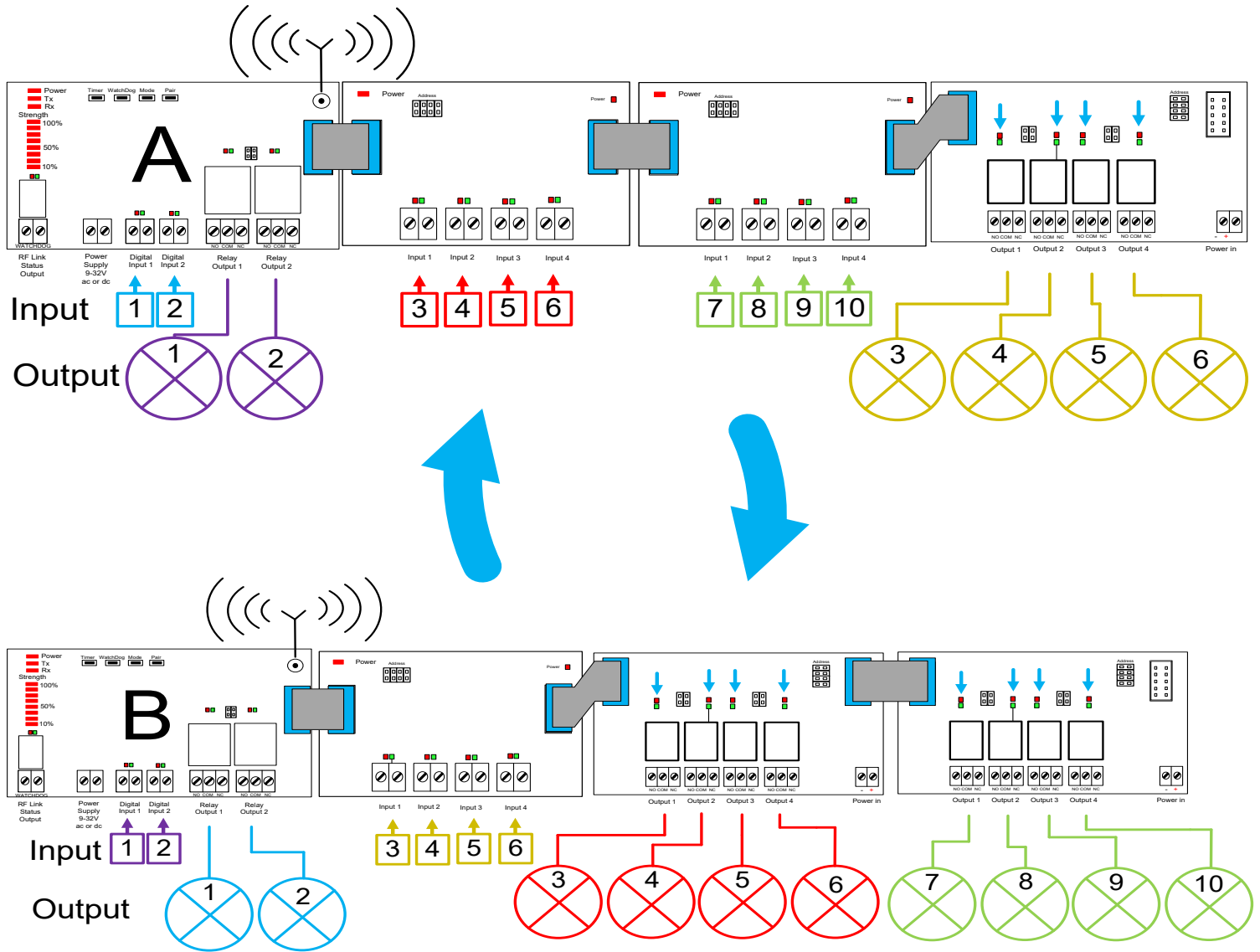

More Advanced Example - using Multiple Transceiver Modules

Application Example

In the example below

'A' input 1 is paired with 'B' Output2

'A' input 2 is paired with 'C' output 1

'B' input 2 is paired with 'C' output 2

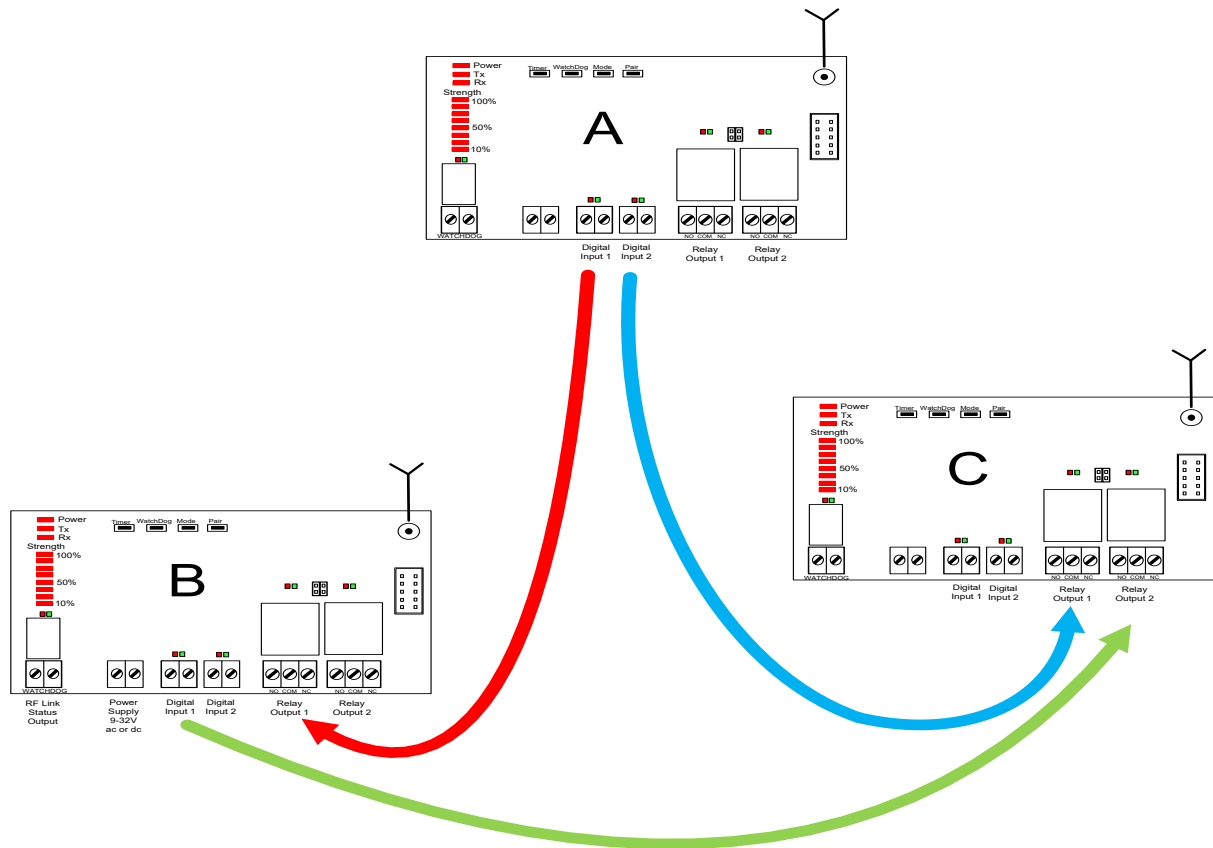

Optional Component Parts / Spares

ENC-DA3 enclosure

- IP65 rated DIN rail enclosure
- 12V volt PSU
- 305mm X 220mm X 125mm
- Premade Back plate with DIN Rail Mount
- Easy clip fit for 700 series products

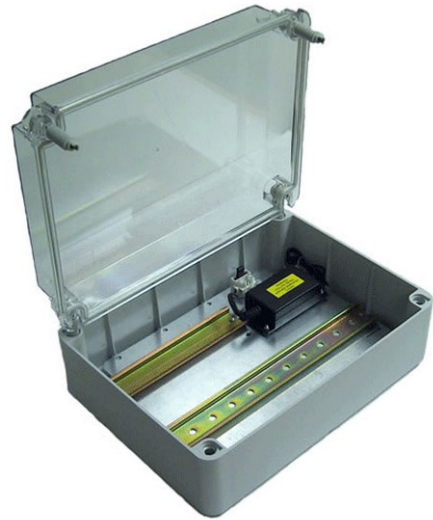

12V1A-IN-IP

- IP67 rated PSU
- 12V volt
- 1Amp



CBA-SMAMR-SMAF

Used for externally mounting an antenna

- SMA Male Right Angle
- 2. SMA Female Bulkhead Straight



ANT-GSM5WM

- Wall mount antenna
- 3m cable
- Wall Mount Whip Antenna
- 824-960
- Active gain: +5dB
- RG58 Connecting Lead



Technical Specifications

Transceiver : 725-TRX

Dimensions: 136 x 78 x 42 mm

Storage Temperature: -10 to +70° Celsius.

Operating Temperature: -10 to +50° Celsius.

Electrical Characteristics	Min	Typical	Max	Units
Supply Voltage	12		32	Vdc or ac
Frequency:		869.500		MHz
RF Output Power (ERP) @ 869.50 MHz	-	100		mW
Supply Current : Quiescent		50		mA
All output relays operating		+101		mA
Watchdog relay operating		+25		mA
When transmitting		+95		mA

Input Module: 725-IP

Dimensions: 68 x 78 x 42 mm

Storage Temperature: -10 to +70° Celsius.

Operating Temperature: -10 to +50° Celsius.

Electrical Characteristics	Min	Typical	Max	Units
Supply Voltage		N/A		V
Input Impedance				Ohms
Supply Current		15		mA

Output Module : 725-OP

Dimensions: 136 x 78 x 42 mm

ELECTRICAL CHARACTERISTICS	MODE	MIN	TYPICAL	MAX	Units
Supply Voltage			N/A		V
Relay Rating* (230Vac) RLY 1-4			5		A(rms)
Time delay from Tx on Switch to Rx Relay operation	FSK		30		mS
	LORA		30-1500		mS
Time delay from Tx sw relax to Rx Relay release	FSK		30		mS
	LORA		30-1500		mS
Supply Current :	Quiescent	12			mA
	All relays operating	+90			mA

Storage Temperature: -10 to +70° Celsius.

Operating Temperature: -10 to +50° Celsius.

Notes

- Notes The power is derived directly from 725-868
- The relay contacts in this unit are for functional use only and must not be used for isolation purposes

Important European compliance information

This RF Solutions product meets the essential requirements of the European Radio Equipment Directive 2014/53/EU and has been tested to European Harmonised Standards and CE marked accordingly. A copy of the EU Declaration of Conformity can be located on the RF Solutions Website, www.rfsolutions.co.uk/certification-i59.

RF Solutions Ltd. Recycling Notice

Meets the following EC Directives:

DO NOT Discard with normal waste, please recycle.

ROHS Directive 2002/95/EC

Specifies certain limits for hazardous substances.

WEEE Directive 2002/96/EC

Waste electrical & electronic equipment. This product must be disposed of through a licensed WEEE collection point. RF Solutions Ltd., fulfils its WEEE obligations by membership of an ap-



**R F Solutions Ltd.,
William Way, Burgess Hill
West Sussex. RH15 9AG England.**

Email : sales@rfsolutions.co.uk <http://www.rfsolutions.co.uk>

Tel Sales: 01444 227910

Tel Technical: 01444 227909

Tel Gen Enq: 01444 227900

Whilst the information in this document is believed to be correct at the time of issue, RF Solutions Ltd does not accept any liability whatsoever for its accuracy, adequacy or completeness. No express or implied warranty or representation is given relating to the information contained in this document. RF Solutions Ltd reserves the right to make changes and improvements to the product(s) described herein without notice. Buyers and other users should determine for themselves the suitability of any such information or products for their own particular requirements or specification(s). RF Solutions Ltd shall not be liable for any loss or damage caused as a result of user's own determination of how to deploy or use RF Solutions Ltd's products. Use of RF Solutions Ltd products or components in life support and/or safety applications is not authorised except with express written approval. No licences are created, implicitly or otherwise, under any of RF Solutions Ltd's intellectual property rights. Liability for loss or damage resulting or caused by reliance on the information contained herein or from the use of the product (including liability resulting from negligence or where RF Solutions Ltd was aware of the possibility of such loss or damage arising) is excluded. This will not operate to limit or restrict RF Solutions Ltd's liability for death or personal injury resulting from its negligence.



Компания «ЭлектроПласт» предлагает заключение долгосрочных отношений при поставках импортных электронных компонентов на взаимовыгодных условиях!

Наши преимущества:

- Оперативные поставки широкого спектра электронных компонентов отечественного и импортного производства напрямую от производителей и с крупнейших мировых складов;
- Поставка более 17-ти миллионов наименований электронных компонентов;
- Поставка сложных, дефицитных, либо снятых с производства позиций;
- Оперативные сроки поставки под заказ (от 5 рабочих дней);
- Экспресс доставка в любую точку России;
- Техническая поддержка проекта, помощь в подборе аналогов, поставка прототипов;
- Система менеджмента качества сертифицирована по Международному стандарту ISO 9001;
- Лицензия ФСБ на осуществление работ с использованием сведений, составляющих государственную тайну;
- Поставка специализированных компонентов (Xilinx, Altera, Analog Devices, Intersil, Interpoint, Microsemi, Aeroflex, Peregrine, Syfer, Eurofarad, Texas Instrument, Miteq, Cobham, E2V, MA-COM, Hittite, Mini-Circuits, General Dynamics и др.);

Помимо этого, одним из направлений компании «ЭлектроПласт» является направление «Источники питания». Мы предлагаем Вам помощь Конструкторского отдела:

- Подбор оптимального решения, техническое обоснование при выборе компонента;
- Подбор аналогов;
- Консультации по применению компонента;
- Поставка образцов и прототипов;
- Техническая поддержка проекта;
- Защита от снятия компонента с производства.



Как с нами связаться

Телефон: 8 (812) 309 58 32 (многоканальный)

Факс: 8 (812) 320-02-42

Электронная почта: org@eplast1.ru

Адрес: 198099, г. Санкт-Петербург, ул. Калинина, дом 2, корпус 4, литера А.