

PEG MOUNT OPTIONS

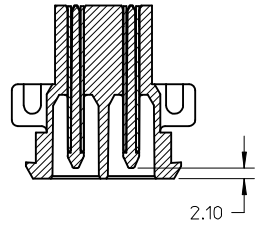

SECTION Z-Z

SCREW MOUNT VERSION

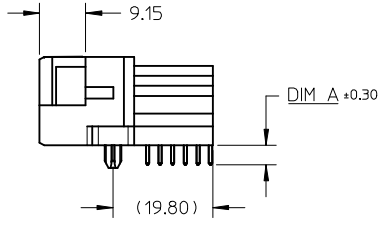
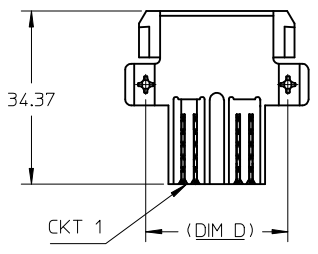
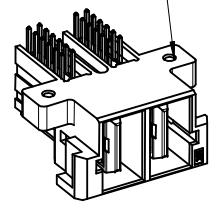

P/N/O: 151035-1***

PEG VERSION

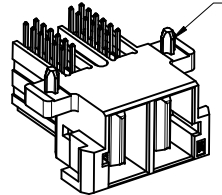

P/N/O: 151035-0***

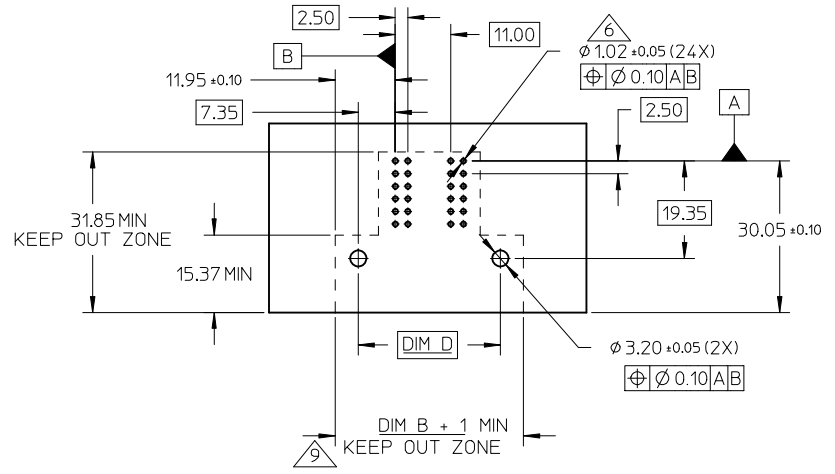

RECOMMENDED PCB LAYOUT (COMPONENT SIDE)

- NOTE:
- MATERIAL:
HOUSING: LCP, UL 94V-0, COLOR: BLACK
TERMINALS: COPPER ALLOY
 - PLATING:
30µ IN GOLD ON CONTACT AREA
100µ IN TIN IN THE PC TAIL AREA OVER
50µ IN NICKEL OVERALL UNDERPLATE
 - PRODUCT SPECIFICATION: PS-151053-0001
 - PARTS TO BE PACKED PER PACKAGING SPEC: PK-151035-0001
 - MATING WITH CRIMP: 46819, RECEPTACLE HOUSING SERIES 151034
 - PCB HOLES TO BE PLATED THRU HOLES.
 - CONTACTS ARE LUBRICATED.
 - RECOMMENDED SCREW: 2-32 TYPE AB X 0.300" (FOR 1.60MM PCB)
2-32 TYPE AB X 0.375" (FOR 2.36 & 3.18MM PCB)
SCREWS ARE SOLD SEPARATELY.
 - KEEP-OUT ZONE DOES NOT TAKE FINGER SPACING INTO ACCOUNT.
PLEASE MAKE SURE TO LEAVE APPROPRIATE CLEARANCE BETWEEN
LATCHES AND ADJACENT PRODUCT FOR PROPER LATCH FUNCTION.

+ SCREW MT OPTIONS	EC NO: S2015-1142	2015/04/08	QUALITY SYMBOLS
	DRWN:CGOH	2015/06/17	
	CHKD:KHLIM	2015/06/17	
	APPR:KHLIM	2015/06/17	
REV	DESCRIPTION		$\nabla_A = 0$ $\nabla_C = 0$ $\nabla_P = 0$

GENERAL TOLERANCES (UNLESS SPECIFIED)	
	mm INCH
4 PLACES	± --- ± ---
3 PLACES	± --- ± ---
2 PLACES	± 0.25 ± ---
1 PLACE	± 0.25 ± ---
0 PLACE	± --- ± ---
ANGULAR ± 3 °	
DRAFT WHERE APPLICABLE MUST REMAIN WITHIN DIMENSIONS	

DIMENSION STYLE		SCALE	DESIGN UNITS	THIRD ANGLE PROJECTION
MM ONLY		NTS	METRIC	
DRAWN BY	DATE	TITLE		
CGOH	2014/04/23	GUARDIAN II		
CHECKED BY	DATE	RA PLUG ASSEMBLY		
EANG	2014/10/21	2 - 6 CKTS		
APPROVED BY	DATE	molex		
KHLIM	2014/10/22			
MATERIAL NO.	DOCUMENT NO.	SHEET NO.		
SEE TABLE	SD-151035-0001	1 OF 2		

THIS DRAWING CONTAINS INFORMATION THAT IS PROPRIETARY TO MOLEX INCORPORATED AND SHOULD NOT BE USED WITHOUT WRITTEN PERMISSION	
---	--

CKT SIZE	PART NO.	DIM A PC TAIL	PC BOARD THICKNESS	PC TAIL TYPE	GUIDE OPTION	DIM B	DIM C	DIM D	DIM E	DIM F
2 CKT	151035-0002	3.86±0.30	2.36	SOLDER TAIL	PEG	36.40	30.84	28.20	43.20	38.60
	151035-0012	4.69±0.30	3.18							
	151035-0022	3.28±0.30	1.60	COMPLIANT PIN						
	151035-1002	3.86±0.30	2.36	SOLDER TAIL	SCREW MOUNT					
	151035-1012	4.69±0.30	3.18							
151035-1022	3.28±0.30	1.60	COMPLIANT PIN							
3 CKT	151035-0003	3.86±0.30	2.36	SOLDER TAIL	PEG	47.40	41.84	39.20	54.20	49.60
	151035-0013	4.69±0.30	3.18							
	151035-0023	3.28±0.30	1.60	COMPLIANT PIN						
	151035-1003	3.86±0.30	2.36	SOLDER TAIL	SCREW MOUNT					
	151035-1013	4.69±0.30	3.18							
151035-1023	3.28±0.30	1.60	COMPLIANT PIN							
4 CKT	151035-0004	3.86±0.30	2.36	SOLDER TAIL	PEG	58.40	52.84	50.20	65.20	60.60
	151035-0014	4.69±0.30	3.18							
	151035-0024	3.28±0.30	1.60	COMPLIANT PIN						
	151035-1004	3.86±0.30	2.36	SOLDER TAIL	SCREW MOUNT					
	151035-1014	4.69±0.30	3.18							
151035-1024	3.28±0.30	1.60	COMPLIANT PIN							
5 CKT	151035-0005	3.86±0.30	2.36	SOLDER TAIL	PEG	69.40	63.84	61.20	76.20	71.60
	151035-0015	4.69±0.30	3.18							
	151035-0025	3.28±0.30	1.60	COMPLIANT PIN						
	151035-1005	3.86±0.30	2.36	SOLDER TAIL	SCREW MOUNT					
	151035-1015	4.69±0.30	3.18							
151035-1025	3.28±0.30	1.60	COMPLIANT PIN							
6 CKT	151035-0006	3.86±0.30	2.36	SOLDER TAIL	PEG	80.40	74.84	72.20	87.20	82.60
	151035-0016	4.69±0.30	3.18							
	151035-0026	3.28±0.30	1.60	COMPLIANT PIN						
	151035-1006	3.86±0.30	2.36	SOLDER TAIL	SCREW MOUNT					
	151035-1016	4.69±0.30	3.18							
151035-1026	3.28±0.30	1.60	COMPLIANT PIN							

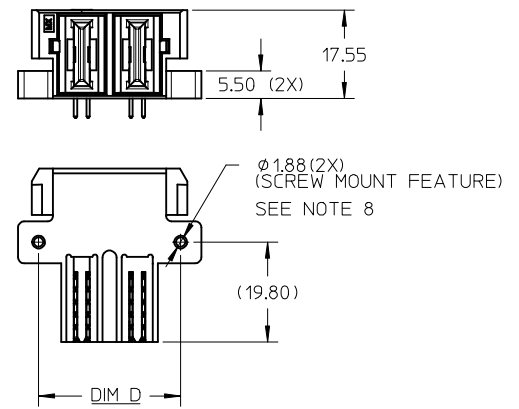

SCREW MOUNT OPTIONS

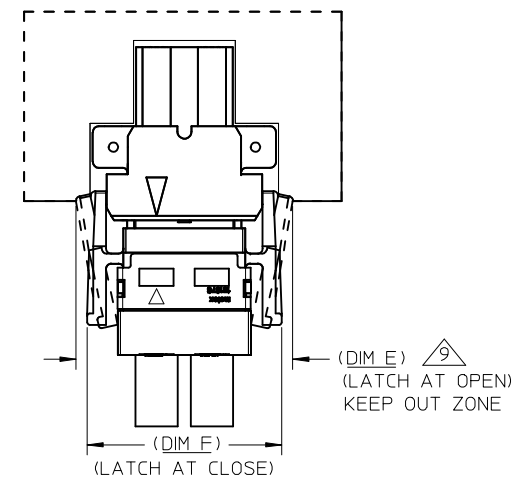

CONNECTOR ASSEMBLY WITH RECEPTACLE CABLE.

+ SCREW MT OPTIONS EC NO: S2015-1142 DRWN:CGOH 2015/04/08 CHKD:EANG 2015/06/17 APPR:KHLIM 2015/06/17	DESCRIPTION REV	QUALITY SYMBOLS	GENERAL TOLERANCES (UNLESS SPECIFIED)	DIMENSION STYLE	SCALE	DESIGN UNITS	THIRD ANGLE PROJECTION
		$\nabla_A = 0$ $\nabla_G = 0$ $\nabla_P = 0$	mm INCH 4 PLACES ± --- ± --- 3 PLACES ± --- ± --- 2 PLACES ± 0.25 ± --- 1 PLACE ± 0.25 ± --- 0 PLACE ± --- ± ---	MM ONLY	1:1	METRIC	
			ANGULAR ± 3 °	DRAWN BY	DATE	TITLE	
			DRAFT WHERE APPLICABLE MUST REMAIN WITHIN DIMENSIONS	CGOH	2014/04/23	GUARDIAN II RA PLUG ASSEMBLY 2 - 6 CKTS	
				EANG	2014/10/21	molex	
				SEE TABLE	SD-151035-0001	SHEET NO. 2 OF 2	
				THIS DRAWING CONTAINS INFORMATION THAT IS PROPRIETARY TO MOLEX INCORPORATED AND SHOULD NOT BE USED WITHOUT WRITTEN PERMISSION			



Компания «ЭлектроПласт» предлагает заключение долгосрочных отношений при поставках импортных электронных компонентов на взаимовыгодных условиях!

Наши преимущества:

- Оперативные поставки широкого спектра электронных компонентов отечественного и импортного производства напрямую от производителей и с крупнейших мировых складов;
- Поставка более 17-ти миллионов наименований электронных компонентов;
- Поставка сложных, дефицитных, либо снятых с производства позиций;
- Оперативные сроки поставки под заказ (от 5 рабочих дней);
- Экспресс доставка в любую точку России;
- Техническая поддержка проекта, помощь в подборе аналогов, поставка прототипов;
- Система менеджмента качества сертифицирована по Международному стандарту ISO 9001;
- Лицензия ФСБ на осуществление работ с использованием сведений, составляющих государственную тайну;
- Поставка специализированных компонентов (Xilinx, Altera, Analog Devices, Intersil, Interpoint, Microsemi, Aeroflex, Peregrine, Syfer, Eurofarad, Texas Instrument, Miteq, Cobham, E2V, MA-COM, Hittite, Mini-Circuits, General Dynamics и др.);

Помимо этого, одним из направлений компании «ЭлектроПласт» является направление «Источники питания». Мы предлагаем Вам помощь Конструкторского отдела:

- Подбор оптимального решения, техническое обоснование при выборе компонента;
- Подбор аналогов;
- Консультации по применению компонента;
- Поставка образцов и прототипов;
- Техническая поддержка проекта;
- Защита от снятия компонента с производства.



Как с нами связаться

Телефон: 8 (812) 309 58 32 (многоканальный)

Факс: 8 (812) 320-02-42

Электронная почта: org@eplast1.ru

Адрес: 198099, г. Санкт-Петербург, ул. Калинина, дом 2, корпус 4, литера А.