



MCP1603
Buck Converter
Evaluation Board
User's Guide

Note the following details of the code protection feature on Microchip devices:

- Microchip products meet the specification contained in their particular Microchip Data Sheet.
- Microchip believes that its family of products is one of the most secure families of its kind on the market today, when used in the intended manner and under normal conditions.
- There are dishonest and possibly illegal methods used to breach the code protection feature. All of these methods, to our knowledge, require using the Microchip products in a manner outside the operating specifications contained in Microchip's Data Sheets. Most likely, the person doing so is engaged in theft of intellectual property.
- Microchip is willing to work with the customer who is concerned about the integrity of their code.
- Neither Microchip nor any other semiconductor manufacturer can guarantee the security of their code. Code protection does not mean that we are guaranteeing the product as "unbreakable."

Code protection is constantly evolving. We at Microchip are committed to continuously improving the code protection features of our products. Attempts to break Microchip's code protection feature may be a violation of the Digital Millennium Copyright Act. If such acts allow unauthorized access to your software or other copyrighted work, you may have a right to sue for relief under that Act.

Information contained in this publication regarding device applications and the like is provided only for your convenience and may be superseded by updates. It is your responsibility to ensure that your application meets with your specifications. MICROCHIP MAKES NO REPRESENTATIONS OR WARRANTIES OF ANY KIND WHETHER EXPRESS OR IMPLIED, WRITTEN OR ORAL, STATUTORY OR OTHERWISE, RELATED TO THE INFORMATION, INCLUDING BUT NOT LIMITED TO ITS CONDITION, QUALITY, PERFORMANCE, MERCHANTABILITY OR FITNESS FOR PURPOSE. Microchip disclaims all liability arising from this information and its use. Use of Microchip devices in life support and/or safety applications is entirely at the buyer's risk, and the buyer agrees to defend, indemnify and hold harmless Microchip from any and all damages, claims, suits, or expenses resulting from such use. No licenses are conveyed, implicitly or otherwise, under any Microchip intellectual property rights.

Trademarks

The Microchip name and logo, the Microchip logo, Accuron, dsPIC, KEELOQ, KEELOQ logo, microID, MPLAB, PIC, PICmicro, PICSTART, PRO MATE, rfPIC and SmartShunt are registered trademarks of Microchip Technology Incorporated in the U.S.A. and other countries.

AmpLab, FilterLab, Linear Active Thermistor, Migratable Memory, MXDEV, MXLAB, SEEVAL, SmartSensor and The Embedded Control Solutions Company are registered trademarks of Microchip Technology Incorporated in the U.S.A.

Analog-for-the-Digital Age, Application Maestro, CodeGuard, dsPICDEM, dsPICDEM.net, dsPICworks, ECAN, ECONOMONITOR, FanSense, FlexROM, fuzzyLAB, In-Circuit Serial Programming, ICSP, ICEPIC, Mindi, MiWi, MPASM, MPLAB Certified logo, MPLIB, MPLINK, PICkit, PICDEM, PICDEM.net, PICLAB, PICtail, PowerCal, PowerInfo, PowerMate, PowerTool, REAL ICE, rFLAB, Select Mode, Smart Serial, SmartTel, Total Endurance, UNI/O, WiperLock and ZENA are trademarks of Microchip Technology Incorporated in the U.S.A. and other countries.

SQTP is a service mark of Microchip Technology Incorporated in the U.S.A.

All other trademarks mentioned herein are property of their respective companies.

© 2007, Microchip Technology Incorporated, Printed in the U.S.A., All Rights Reserved.

 Printed on recycled paper.

QUALITY MANAGEMENT SYSTEM
CERTIFIED BY DNV
== ISO/TS 16949:2002 ==

Microchip received ISO/TS-16949:2002 certification for its worldwide headquarters, design and wafer fabrication facilities in Chandler and Tempe, Arizona; Gresham, Oregon and design centers in California and India. The Company's quality system processes and procedures are for its PIC® MCUs and dsPIC® DSCs, KEELOQ® code hopping devices, Serial EEPROMs, microperipherals, nonvolatile memory and analog products. In addition, Microchip's quality system for the design and manufacture of development systems is ISO 9001:2000 certified.



MCP1603 BUCK CONVERTER EVALUATION BOARD USER'S GUIDE

Table of Contents

Preface	1
Introduction.....	1
Document Layout	1
Conventions Used in this Guide	2
Recommended Reading.....	2
The Microchip Web Site	3
Customer Support	3
Document Revision History	3
Chapter 1. Product Overview	5
1.1 Introduction	5
1.2 What is the MCP1603 Buck Converter Evaluation Board?	6
1.3 What the MCP1603 Buck Converter Evaluation Board Kit includes	6
Chapter 2. Installation and Operation	7
2.1 Introduction	7
2.2 Features	7
2.3 Getting Started	7
Appendix A. Schematic and Layouts	9
A.1 Introduction	9
A.2 Board - Schematic	10
A.3 Board - Top Silk Layer	11
A.4 Board - Top Metal Layer	12
A.5 Board - Bottom Metal Layer	13
Appendix B. Bill Of Materials (BOM)	15
Worldwide Sales and Service	16

MCP1603 Buck Converter Evaluation Board User's Guide

NOTES:



MCP1603 BUCK CONVERTER EVALUATION BOARD USER'S GUIDE

Preface

NOTICE TO CUSTOMERS

All documentation becomes dated, and this manual is no exception. Microchip tools and documentation are constantly evolving to meet customer needs, so some actual dialogs and/or tool descriptions may differ from those in this document. Please refer to our web site (www.microchip.com) to obtain the latest documentation available.

Documents are identified with a "DS" number. This number is located on the bottom of each page, in front of the page number. The numbering convention for the DS number is "DSXXXXA", where "XXXX" is the document number and "A" is the revision level of the document.

For the most up-to-date information on development tools, see the MPLAB® IDE on-line help. Select the Help menu, and then Topics to open a list of available on-line help files.

INTRODUCTION

This chapter contains general information that will be useful to know before using the MCP1603 Buck Converter Evaluation Board. Items discussed in this chapter include:

- Document Layout
- Conventions Used in this Guide
- Recommended Reading
- The Microchip Web Site
- Customer Support
- Document Revision History

DOCUMENT LAYOUT

This document describes how to use the MCP1603 Buck Converter Evaluation Board as a development tool to evaluate the MCP1603. The manual layout is as follows:

- **Chapter 1. "Product Overview"** – Important information about the MCP1603 Buck Converter Evaluation Board.
- **Chapter 2. "Installation and Operation"** – Includes instructions on how to get started with this user's guide and a description of the user's guide.
- **Appendix A. "Schematic and Layouts"** – Shows the schematic and layout diagrams for the MCP1603 Buck Converter Evaluation Board.
- **Appendix B. "Bill Of Materials (BOM)"** – Lists the parts used to build the MCP1603 Buck Converter Evaluation Board.

MCP1603 Buck Converter Evaluation Board User's Guide

CONVENTIONS USED IN THIS GUIDE

This manual uses the following documentation conventions:

DOCUMENTATION CONVENTIONS

Description	Represents	Examples
Arial font:		
Italic characters	Referenced books	<i>MPLAB® IDE User's Guide</i>
	Emphasized text	...is the <i>only</i> compiler...
Initial caps	A window	the Output window
	A dialog	the Settings dialog
	A menu selection	select Enable Programmer
Quotes	A field name in a window or dialog	"Save project before build"
Underlined, italic text with right angle bracket	A menu path	<u><i>File>Save</i></u>
Bold characters	A dialog button	Click OK
	A tab	Click the Power tab
N'Rnnnn	A number in verilog format, where N is the total number of digits, R is the radix and n is a digit.	4'b0010, 2'hF1
Text in angle brackets < >	A key on the keyboard	Press <Enter>, <F1>
Courier New font:		
Plain Courier New	Sample source code	#define START
	Filenames	autoexec.bat
	File paths	c:\mcc18\h
	Keywords	_asm, _endasm, static
	Command-line options	-Opa+, -Opa-
	Bit values	0, 1
	Constants	0xFF, 'A'
Italic Courier New	A variable argument	<i>file.o</i> , where <i>file</i> can be any valid filename
Square brackets []	Optional arguments	mcc18 [options] <i>file</i> [options]
Curly brackets and pipe character: { }	Choice of mutually exclusive arguments; an OR selection	errorlevel {0 1}
Ellipses...	Replaces repeated text	var_name [, var_name...]
	Represents code supplied by user	void main (void) { ... }

RECOMMENDED READING

This user's guide describes how to use MCP1603 Buck Converter Evaluation Board. Other useful documents are listed below. The following Microchip documents are available and recommended as supplemental reference resources.

MCP1603 Data Sheet, "2.0 MHz, 500 mA Synchronous Buck Regulator" (DS22042)

This data sheet provides detailed information regarding the MCP1603 Buck Regulator product.

THE MICROCHIP WEB SITE

Microchip provides online support via our web site at www.microchip.com. This web site is used as a means to make files and information easily available to customers. Accessible by using your favorite Internet browser, the web site contains the following information:

- **Product Support** – Data sheets and errata, application notes and sample programs, design resources, user's guides and hardware support documents, latest software releases and archived software
- **General Technical Support** – Frequently Asked Questions (FAQs), technical support requests, online discussion groups, Microchip consultant program member listing
- **Business of Microchip** – Product selector and ordering guides, latest Microchip press releases, listing of seminars and events, listings of Microchip sales offices, distributors and factory representatives

CUSTOMER SUPPORT

Users of Microchip products can receive assistance through several channels:

- Distributor or Representative
- Local Sales Office
- Field Application Engineer (FAE)
- Technical Support

Customers should contact their distributor, representative or field application engineer for support. Local sales offices are also available to help customers. A listing of sales offices and locations is included in the back of this document.

Technical support is available through the web site at: <http://support.microchip.com>

DOCUMENT REVISION HISTORY

Revision A (May 2007)

- Initial Release of this Document.

MCP1603 Buck Converter Evaluation Board User's Guide

NOTES:

Chapter 1. Product Overview

1.1 INTRODUCTION

Step-down converter choices include a variety of linear and switching regulators. The MCP1603 500 mA synchronous buck regulator provides a low profile, cost effective, and efficient solution for devices like cellular telephones, USB-powered devices and hand held instruments. The device provides a solution with minimal board space because of the high-frequency operation, which reduces the size requirements of the external inductor and capacitor and the 1 mm maximum height TSOT package.

The MCP1603 switches at a fixed frequency of 2.0 MHz when operating at a heavy load. This provides a low-noise, small size solution. When operating at light loads, the MCP1603 changes operation to a pulse frequency modulation (PFM) mode to minimize quiescent current drawn from the input source. No intervention is necessary for smooth transition from one mode to another.

This chapter covers the following topics.

- "What is the MCP1603 Buck Converter Evaluation Board?"
- "What the MCP1603 Buck Converter Evaluation Board Kit includes."

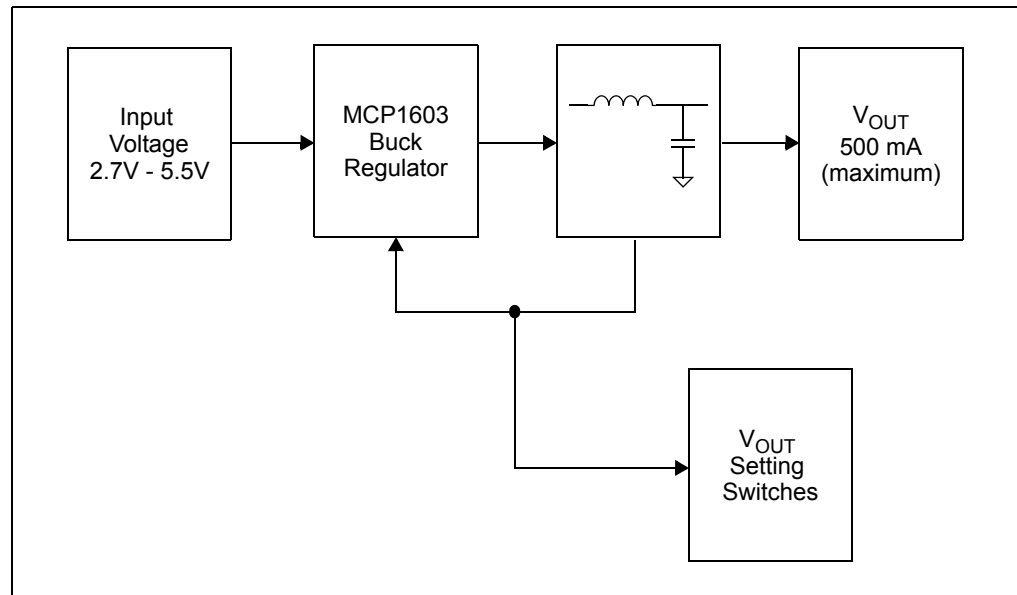

FIGURE 1-1: MCP1603 Buck Converter Evaluation Board Block Diagram.

MCP1603 Buck Converter Evaluation Board User's Guide

1.2 WHAT IS THE MCP1603 BUCK CONVERTER EVALUATION BOARD?

The MCP1603 Buck Converter Evaluation Board demonstrates the use of Microchip's MCP1603 device in a step-down application. The evaluation board is a fully functional platform to evaluate the MCP1603 buck regulator over the input voltage, output voltage and current range of the device.

Test points are provided to allow easy connection of the input voltage source and the output load.

1.3 WHAT THE MCP1603 BUCK CONVERTER EVALUATION BOARD KIT INCLUDES

This MCP1603 Buck Converter Evaluation Board kit includes:

- MCP1603 Buck Converter Evaluation Board (102-00133)
- Analog and Interface Products Demonstration Boards CD-ROM (DS21912)
 - MCP1603 Buck Converter Evaluation Board User's Guide (DS51652)

Chapter 2. Installation and Operation

2.1 INTRODUCTION

The MCP1603 Buck Converter Evaluation Board is designed to demonstrate Microchip's MCP1603 in an adjustable output voltage configuration. The MCP1603 is a 500 mA synchronous buck regulator that features both Pulse Frequency Modulation (PFM) and Pulse Width Modulation (PWM). The PFM mode is used at light loads to improve system efficiency while the 2.0 MHz PWM mode is entered at heavy loads. The transition between PFM and PWM modes automatically occurs without any external intervention. The MCP1603 is available in both adjustable parts that require an external divider to set the output voltage and fixed output voltage parts.

The high switching speed and TSOT package (1 mm maximum height) make the MCP1603 ideal for space constrained applications that require an efficient stepped down voltage.

2.2 FEATURES

The MCP1603 Buck Converter Evaluation Board has the following features:

- Compact size and low profile 500 mA converter design.
- Wide Input voltage range from 2.7V to 5.5V.
- Five different output voltage settings: 0.8V, 1.2V, 1.8V, 2.5V, and 3.3V.
- Test points for connecting input voltage source and external load.

2.3 GETTING STARTED

The MCP1603 Buck Converter Evaluation Board is fully assembled and tested for evaluating the MCP1603 device. The board requires the use of an external input voltage source of 2.7V to 5.5V and an external load capable of 500 mA.

2.3.1 Power Input and Output Connection

2.3.1.1 POWERING THE MCP1603 BUCK CONVERTER EVALUATION BOARD

1. Connect the positive side of the input source (+) to TP1 (VIN).
2. Connect the negative or return side (-) of input source to TP2 (GND). Refer to Figure 2-1. The input voltage should be limited from 2.7V to 5.5V range.

MCP1603 Buck Converter Evaluation Board User's Guide

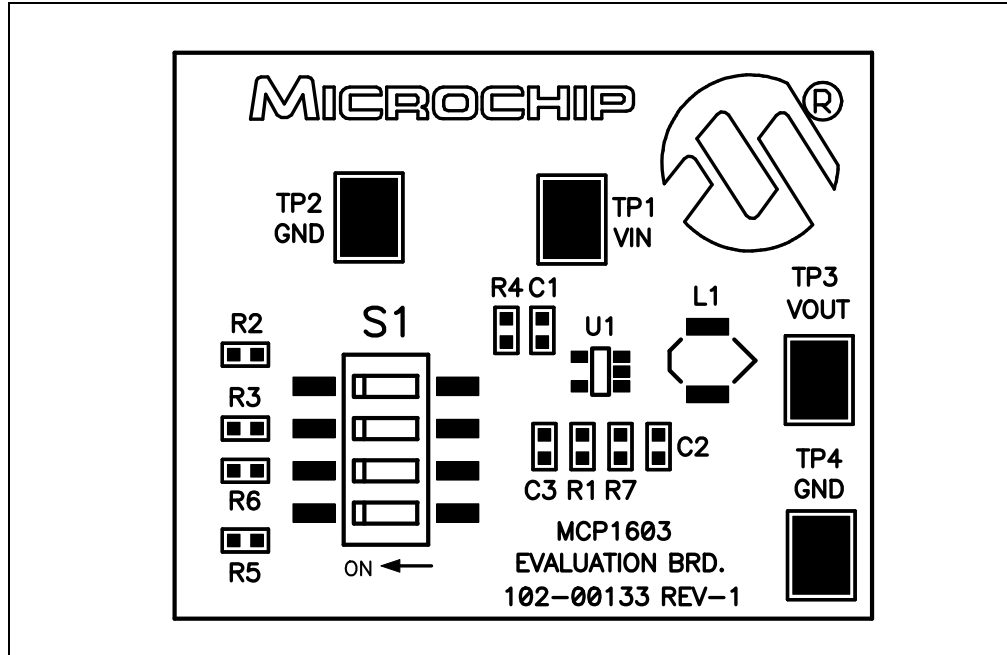

FIGURE 2-1: Setup Configuration Diagram.

2.3.1.2 APPLYING LOAD TO MCP1603 BUCK CONVERTER EVALUATION BOARD

1. Connect the positive side of the load (+) to TP3 (VOUT).
2. Connect the negative side of the load (-) to TP4 (GND). Refer to Figure 2-1. The maximum load current should not exceed 500 mA.

As an alternative, a resistor can be connected between TP3 and TP4. The value of this resistor must be sized such that the maximum load current does not exceed 500 mA for the selected output voltage.

2.3.1.3 SETTING THE OUTPUT VOLTAGE ON THE MCP1603 BUCK CONVERTER EVALUATION BOARD

The output voltage of the MCP1603 Buck Converter Evaluation Board is set by the position of switch S1 locations. Table 2-1 shows the position of the four S1 switch locations to achieve the five different standard output voltages.

TABLE 2-1: SETTING THE OUTPUT VOLTAGE

Output Voltage	S1 - POS1	S1 - POS2	S1 - POS3	S1 - POS4
0.8V	Off	Off	Off	Off
1.2V	Off	Off	Off	On
1.8V	Off	Off	On	Off
2.5V	Off	On	Off	Off
3.3V	On	Off	Off	Off

Evaluating the Application

The best way to evaluate the MCP1603 Buck Converter Evaluation Board is to dig into the circuit. Measure voltages and currents with a DVM and probe the board with an oscilloscope.



MCP1603 BUCK CONVERTER EVALUATION BOARD USER'S GUIDE

Appendix A. Schematic and Layouts

A.1 INTRODUCTION

This appendix contains the following schematics and layouts for the MCP1603 Buck Converter Evaluation Board:

- Board – Schematic
- Board – Top Silk Layer
- Board – Top Metal Layer
- Board – Bottom Metal Layer

MCP1603 Buck Converter Evaluation Board User's Guide

A.2 BOARD - SCHEMATIC

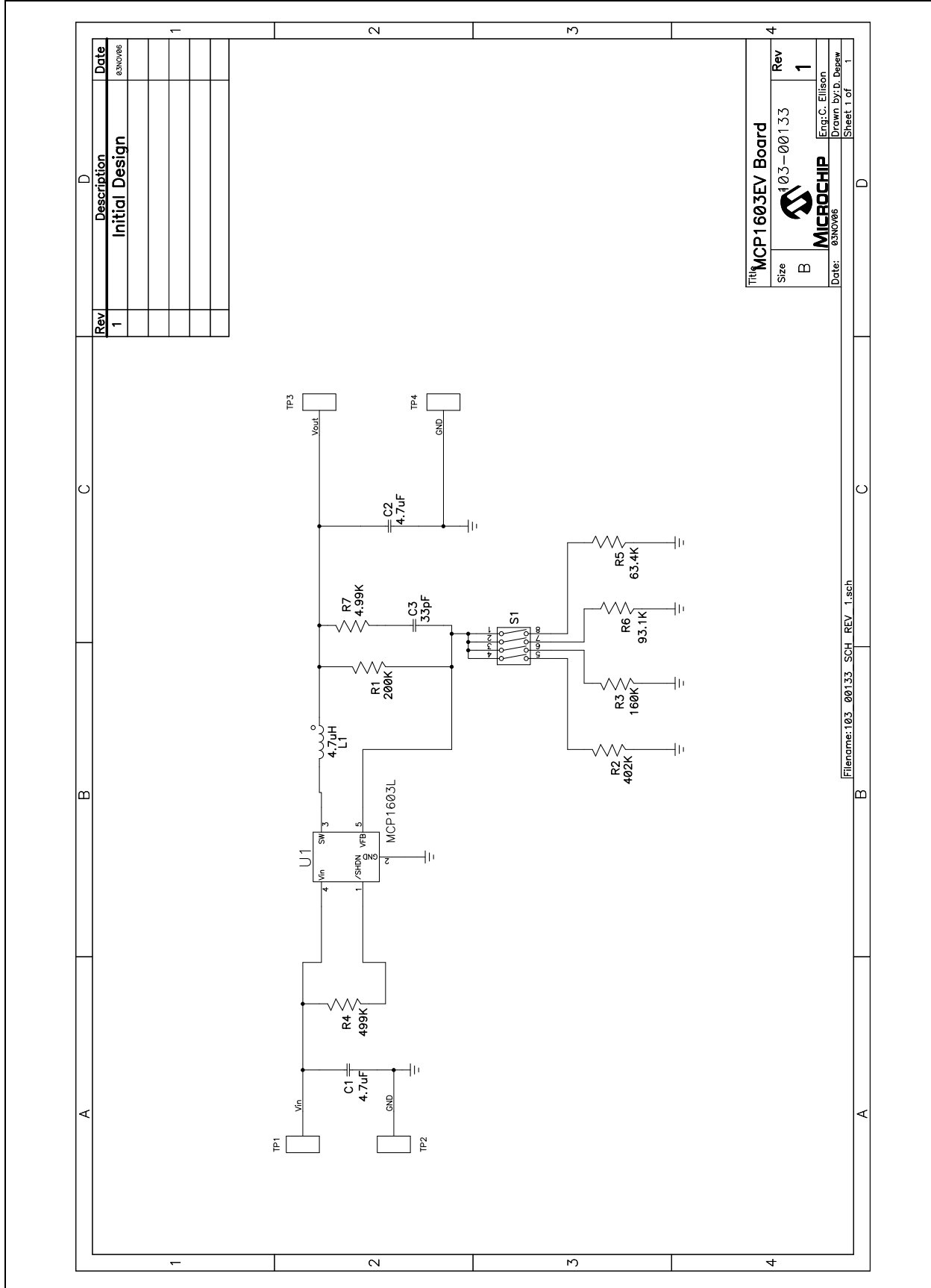

A.3 BOARD - TOP SILK LAYER

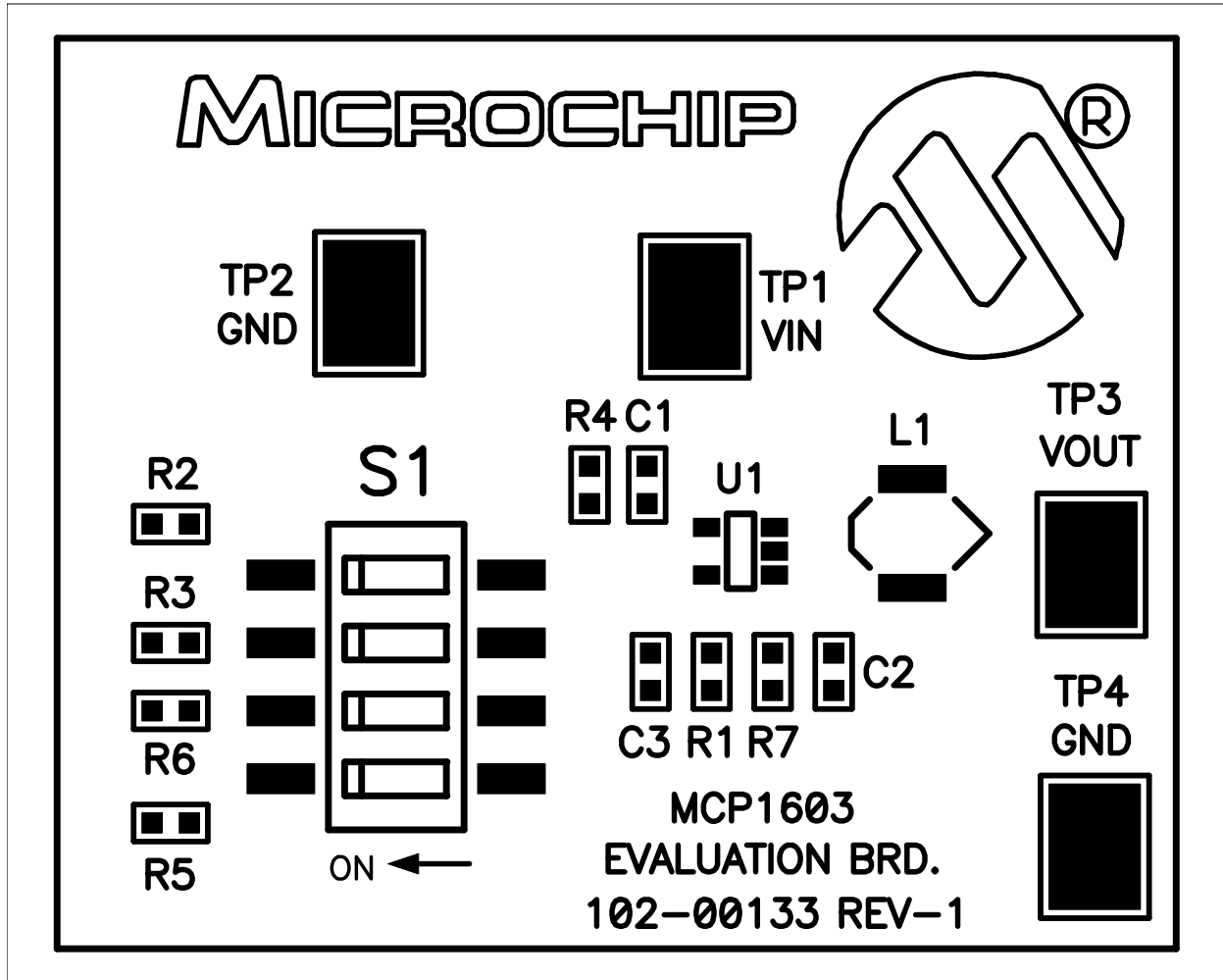

MCP1603 Buck Converter Evaluation Board User's Guide

A.4 BOARD - TOP METAL LAYER

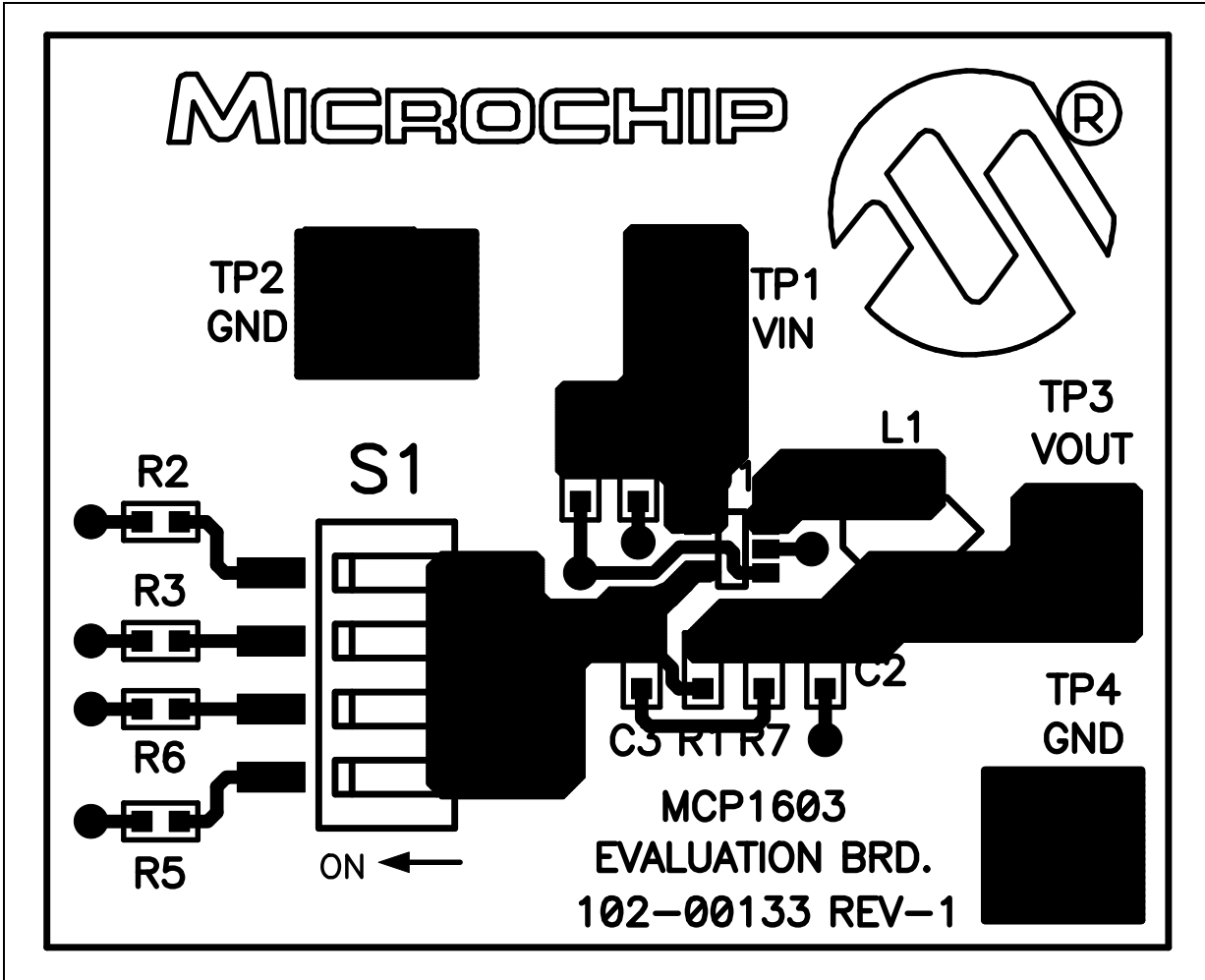

A.5 BOARD - BOTTOM METAL LAYER

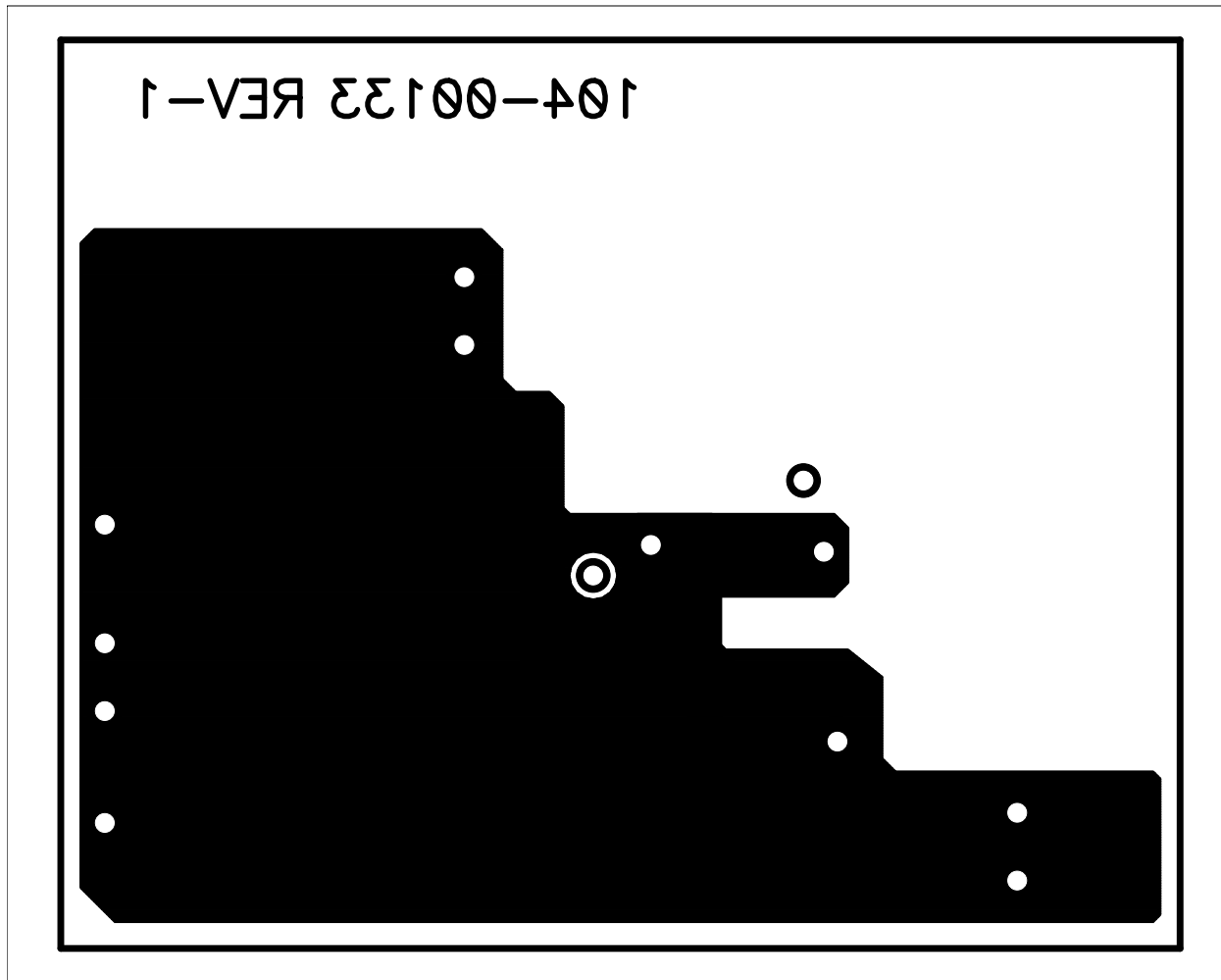

MCP1603 Buck Converter Evaluation Board User's Guide

NOTES:

Appendix B. Bill Of Materials (BOM)

TABLE B-1: BILL OF MATERIALS (BOM)

Qty	Reference	Description	Manufacturer	Part Number
2	C1, C2	Cap Ceramic 4.7 μ F 6.3V X5R 0603	Panasonic [®] - ECG	ECJ-1VB0J475K
1	C3	Cap Ceramic 33 pF 50V 0603	Panasonic - ECG	ECJ-1VC1H330J
1	L1	4.7 μ H Inductor	Coiltronics	SD3812-4R7-R
1	R1	Res 200 k Ω 1/10W 1% 0603	Panasonic - ECG	ERJ-3EKF2003V
1	R2	Res 402 k Ω 1/10W 1% 0603	Panasonic - ECG	ERJ-3EKF4023V
1	R3	Res 160 k Ω 1/10W 5% 0603	Panasonic - ECG	ERJ-3GEYJ164V
1	R4	Res 499 k Ω 1/10W 1% 0603	Panasonic - ECG	ERJ-3EKF4993V
1	R5	Res 63.4 k Ω 1/10W 1% 0603	Panasonic - ECG	ERJ-3EKF6342V
1	R6	Res 93.1 k Ω 1/10W 1% 0603	Panasonic - ECG	ERJ-3EKF9312V
1	R7	Res 4.99 k Ω 1/10W 1% 0603	Panasonic - ECG	ERJ-3EKF4991V
1	S1	Switch DIP SPST Sealed 4POS SMD	ITT Industries / C&K Div	SD04H1SK
4	TP1, TP2, TP3, TP4	PC Test Point Compact SMD	Keystone Electronics [®]	5016
1	U1	500 mA Synchronous Buck Regulator	Microchip Technology Inc.	MCP1603L-ADJI/OS

Note 1: The components listed in this Bill of Materials are representative of the PCB assembly. The released BOM used in manufacturing uses all RoHS-compliant components.



WORLDWIDE SALES AND SERVICE

AMERICAS

Corporate Office
2355 West Chandler Blvd.
Chandler, AZ 85224-6199
Tel: 480-792-7200
Fax: 480-792-7277
Technical Support:
<http://support.microchip.com>
Web Address:
www.microchip.com

Atlanta
Duluth, GA
Tel: 678-957-9614
Fax: 678-957-1455

Boston
Westborough, MA
Tel: 774-760-0087
Fax: 774-760-0088

Chicago
Itasca, IL
Tel: 630-285-0071
Fax: 630-285-0075

Dallas
Addison, TX
Tel: 972-818-7423
Fax: 972-818-2924

Detroit
Farmington Hills, MI
Tel: 248-538-2250
Fax: 248-538-2260

Kokomo
Kokomo, IN
Tel: 765-864-8360
Fax: 765-864-8387

Los Angeles
Mission Viejo, CA
Tel: 949-462-9523
Fax: 949-462-9608

Santa Clara
Santa Clara, CA
Tel: 408-961-6444
Fax: 408-961-6445

Toronto
Mississauga, Ontario,
Canada
Tel: 905-673-0699
Fax: 905-673-6509

ASIA/PACIFIC

Asia Pacific Office
Suites 3707-14, 37th Floor
Tower 6, The Gateway
Harbour City, Kowloon
Hong Kong
Tel: 852-2401-1200
Fax: 852-2401-3431

Australia - Sydney
Tel: 61-2-9868-6733
Fax: 61-2-9868-6755

China - Beijing
Tel: 86-10-8528-2100
Fax: 86-10-8528-2104

China - Chengdu
Tel: 86-28-8665-5511
Fax: 86-28-8665-7889

China - Fuzhou
Tel: 86-591-8750-3506
Fax: 86-591-8750-3521

China - Hong Kong SAR
Tel: 852-2401-1200
Fax: 852-2401-3431

China - Qingdao
Tel: 86-532-8502-7355
Fax: 86-532-8502-7205

China - Shanghai
Tel: 86-21-5407-5533
Fax: 86-21-5407-5066

China - Shenyang
Tel: 86-24-2334-2829
Fax: 86-24-2334-2393

China - Shenzhen
Tel: 86-755-8203-2660
Fax: 86-755-8203-1760

China - Shunde
Tel: 86-757-2839-5507
Fax: 86-757-2839-5571

China - Wuhan
Tel: 86-27-5980-5300
Fax: 86-27-5980-5118

China - Xian
Tel: 86-29-8833-7250
Fax: 86-29-8833-7256

ASIA/PACIFIC

India - Bangalore
Tel: 91-80-4182-8400
Fax: 91-80-4182-8422

India - New Delhi
Tel: 91-11-4160-8631
Fax: 91-11-4160-8632

India - Pune
Tel: 91-20-2566-1512
Fax: 91-20-2566-1513

Japan - Yokohama
Tel: 81-45-471-6166
Fax: 81-45-471-6122

Korea - Gumi
Tel: 82-54-473-4301
Fax: 82-54-473-4302

Korea - Seoul
Tel: 82-2-554-7200
Fax: 82-2-558-5932 or
82-2-558-5934

Malaysia - Penang
Tel: 60-4-646-8870
Fax: 60-4-646-5086

Philippines - Manila
Tel: 63-2-634-9065
Fax: 63-2-634-9069

Singapore
Tel: 65-6334-8870
Fax: 65-6334-8850

Taiwan - Hsin Chu
Tel: 886-3-572-9526
Fax: 886-3-572-6459

Taiwan - Kaohsiung
Tel: 886-7-536-4818
Fax: 886-7-536-4803

Taiwan - Taipei
Tel: 886-2-2500-6610
Fax: 886-2-2508-0102

Thailand - Bangkok
Tel: 66-2-694-1351
Fax: 66-2-694-1350

EUROPE

Austria - Wels
Tel: 43-7242-2244-39
Fax: 43-7242-2244-393

Denmark - Copenhagen
Tel: 45-4450-2828
Fax: 45-4485-2829

France - Paris
Tel: 33-1-69-53-63-20
Fax: 33-1-69-30-90-79

Germany - Munich
Tel: 49-89-627-144-0
Fax: 49-89-627-144-44

Italy - Milan
Tel: 39-0331-742611
Fax: 39-0331-466781

Netherlands - Drunen
Tel: 31-416-690399
Fax: 31-416-690340

Spain - Madrid
Tel: 34-91-708-08-90
Fax: 34-91-708-08-91

UK - Wokingham
Tel: 44-118-921-5869
Fax: 44-118-921-5820



Компания «ЭлектроПласт» предлагает заключение долгосрочных отношений при поставках импортных электронных компонентов на взаимовыгодных условиях!

Наши преимущества:

- Оперативные поставки широкого спектра электронных компонентов отечественного и импортного производства напрямую от производителей и с крупнейших мировых складов;
- Поставка более 17-ти миллионов наименований электронных компонентов;
- Поставка сложных, дефицитных, либо снятых с производства позиций;
- Оперативные сроки поставки под заказ (от 5 рабочих дней);
- Экспресс доставка в любую точку России;
- Техническая поддержка проекта, помощь в подборе аналогов, поставка прототипов;
- Система менеджмента качества сертифицирована по Международному стандарту ISO 9001;
- Лицензия ФСБ на осуществление работ с использованием сведений, составляющих государственную тайну;
- Поставка специализированных компонентов (Xilinx, Altera, Analog Devices, Intersil, Interpoint, Microsemi, Aeroflex, Peregrine, Syfer, Eurofarad, Texas Instrument, Miteq, Cobham, E2V, MA-COM, Hittite, Mini-Circuits, General Dynamics и др.);

Помимо этого, одним из направлений компании «ЭлектроПласт» является направление «Источники питания». Мы предлагаем Вам помощь Конструкторского отдела:

- Подбор оптимального решения, техническое обоснование при выборе компонента;
- Подбор аналогов;
- Консультации по применению компонента;
- Поставка образцов и прототипов;
- Техническая поддержка проекта;
- Защита от снятия компонента с производства.



Как с нами связаться

Телефон: 8 (812) 309 58 32 (многоканальный)

Факс: 8 (812) 320-02-42

Электронная почта: org@eplast1.ru

Адрес: 198099, г. Санкт-Петербург, ул. Калинина, дом 2, корпус 4, литера А.