

# D6 - SERIES

## SPECIFICATIONS AND ORDERING INFORMATION

1.687" DIAMETER 1.5 AMPS @ 28 VDC

The D6 Series is one of our more versatile rotary switches. A 30° index angle, solder lug terminals, and diallyl phthalate insulation are standard. However, additional indexes of 36°, 45°, and 60° and insulation sections of glass epoxy and ceramic are available. Adjustable stops are available on indexes of 30° and 60°.



### SPECIFICATIONS

#### ELECTRICAL

**Current and Voltage Rating:** Make and break resistive load  
1.5 amps @ 28 VDC; 0.5 amp @ 115 VAC.  
**Current Carrying Capacity:** 9 amps.  
**Dielectric Strength:** 1,500 VAC between current carrying parts and ground.  
**Contact Resistance:** Average initial 3.5 milliohms.  
**Insulation Resistance:** Diallyl in excess of 900,000 megohms  
Glass in excess of 750,000 megohms.  
Ceramic in excess of 1,000,000 megohms.  
**Hardware:** Mounting nut and lockwasher are shipped assembled.

#### MECHANICAL

**Materials and Finishes:** All parts utilize non-corrosive materials as standard.  
**Clips and Rotors:** Brass with silver plate as standard.  
**Insulation:** Diallyl phthalate, glass, or ceramic.  
**Index:** Dual-ball, side thrust design.  
**Index Life:** 25,000 cycles minimum.  
**Index Torque:** Switches have lowest practical torque consistent with crisp detenting and smooth, reliable operation.  
**Index Angles:** Positive 30° standard, 36°, 45°, and 60° available.  
**Index Stops:** Adjustable standard, fixed or continuous.  
**Stop Strength:** 25 in. lbs. minimum.

### STANDARD PART NUMBER

#### DIALLYL PHTHALATE INSULATION

SWITCHES - 30° INDEX - ADJUSTABLE STOPS - SOLDER LUG TERMINALS

POLES	ACTIVE POSITIONS	POLES/ SECTION	NO. OF SECTIONS	SHORTING	NON-SHORTING	FIG. *	POLES	ACTIVE POSITIONS	POLES/ SECTION	NO. OF SECTIONS	SHORTING	NON-SHORTING	FIG. *
01	02-12	1	1	D6D0112S	D6D0112N	DD	05	02-03	5	1	D6D0503S	D6D0503N	DR
02	02-12	1	2	D6D0212S	D6D0212N	DD	06	02-12	1	6	D6D0612S	D6D0612N	DD
02	02-06	2	1	D6D0206S	D6D0206N	DL	06	02-06	2	3	D6D0606S	D6D0606N	DL
03	02-12	1	3	D6D0312S	D6D0312N	DD	06	02-05	3	2	D6D0605S	D6D0605N	DO
03	02-05	3	1	D6D0305S	D6D0305N	DO	08	02-06	2	4	D6D0806S	D6D0806N	DL
04	02-12	1	4	D6D0412S	D6D0412N	DD	09	02-05	3	3	D6D0905S	D6D0905N	DO
04	02-06	2	2	D6D0406S	D6D0406N	DL	10	02-03	5	2	D6D1003S	D6D1003N	DR
05	02-12	1	5	D6D0512S	D6D0512N	DD	10	02-06	2	5	D6D1006S	D6D1006N	DL

\* FIGURES ARE SHOWN ON PAGES 55 AND 56.

### DIMENSIONS

#### STANDARD CONSTRUCTION

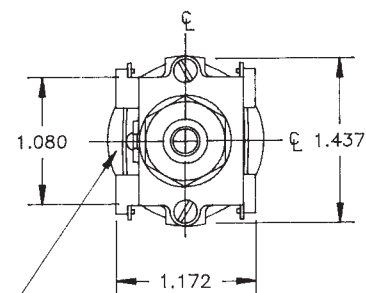

NON-TURN LUG  
.125W X .035 THK.  
.437 FROM C-LINE  
.063 ENGAGEMENT

#### D6D - DIALLYL PHTHALATE CONSTRUCTION

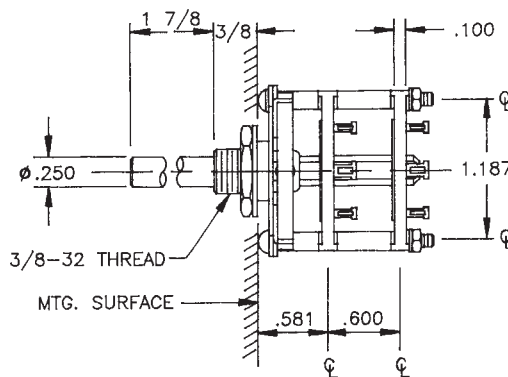

## How to Order Additional Options:

2 DIGIT SERIES	INSULATION TYPE	TOTAL POLES	ACTIVE POSITIONS	CONTACT TYPE	TERMINAL TYPE	INDEX ANGLE	STOP TYPE	SHAFT/ BUSHING	SHAFT FLAT
D6	D - DIALLYL (30°,45°,60°) G - GLASS (30°,36°,45°,60°)	01 - MIN.	12 - MAX @ 30° 10 - MAX @ 36° 08 - MAX @ 45° 06 - MAX @ 60°	S - SHORTING N - NON SHORTING	L - SOLDER LUG R - REAR P.C. (NO 36°)	30° 36° 45° 60°	A - ADJ. (30°,60° ONLY) F - FIXED C - CONT.	SEE CHART "A"	SEE CHART "B"
D6	C - CERAMIC (30°,60°)	01 - MIN.	12 - MAX @ 30° 06 - MAX @ 60°	S - SHORTING N - NON SHORTING	L - SOLDER LUG	30° 60°	A - ADJ. F - FIXED C - CONT.	SEE CHART "A"	SEE CHART "B"

CUSTOMERS SPECIFIED ORDER NUMBER FOR STANDARD OPTIONS

**D 6**

(SPECIFY) (SPECIFY) (SPECIFY) (SPECIFY) (SPECIFY) (SPECIFY) (SPECIFY) (SPECIFY)

### PRINTED BOARD MOUNTING PATTERN

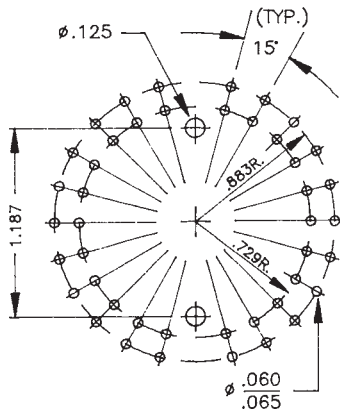

### SHAFT, BUSHING, AND FLAT OPTIONS

P/N OPT.	SHAFT LGTH. "A"	BUSH. LGTH. "B"
01	3/8	1/4
02	3/8	3/8
03	1/2	1/4
04	1/2	3/8
05	9/16	1/4
06	9/16	3/8
07	3/4	1/4
08	3/4	3/8
09	1	1/4
10	1	3/8
11	1 1/2	1/4
12	1 1/2	3/8
13	1 7/8	1/4
14	1 7/8	3/8

P/N OPT.	FLAT ANGLE
B	ROUND - STD
U	15°
W	165°
Y	195°
Z	345°

SHAFT AS VIEWED WITH NON-TURN LUG AT 9 O'CLOCK AND SHAFT IN EXTREME CCW POSITION AND STRUT BOLTS ORIENTED VERTICALLY.

### INSULATION OPTIONS

D6G - GLASS EPOXY INSULATION

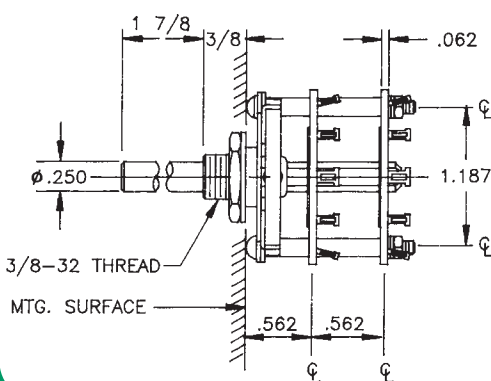

**R** REAR P.C.

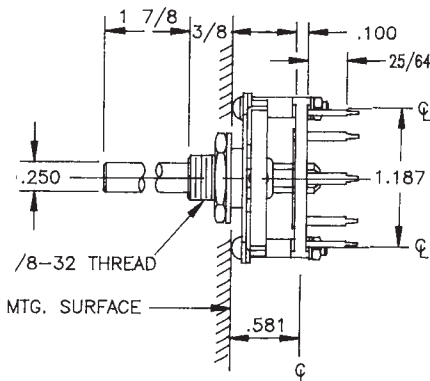

D6C - CERAMIC CONSTRUCTION

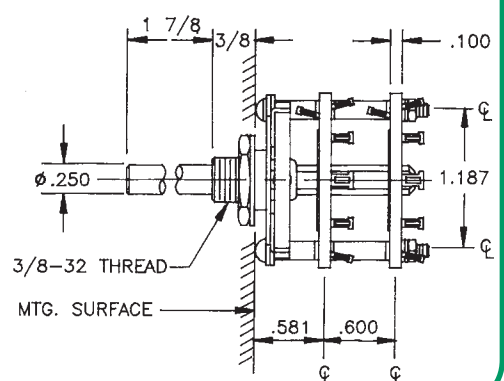

CUSTOM SWITCHES ARE AVAILABLE. CONTACT THE FACTORY WITH YOUR COMPLETE SPECIFICATIONS.



Компания «ЭлектроПласт» предлагает заключение долгосрочных отношений при поставках импортных электронных компонентов на взаимовыгодных условиях!

Наши преимущества:

- Оперативные поставки широкого спектра электронных компонентов отечественного и импортного производства напрямую от производителей и с крупнейших мировых складов;
- Поставка более 17-ти миллионов наименований электронных компонентов;
- Поставка сложных, дефицитных, либо снятых с производства позиций;
- Оперативные сроки поставки под заказ (от 5 рабочих дней);
- Экспресс доставка в любую точку России;
- Техническая поддержка проекта, помощь в подборе аналогов, поставка прототипов;
- Система менеджмента качества сертифицирована по Международному стандарту ISO 9001;
- Лицензия ФСБ на осуществление работ с использованием сведений, составляющих государственную тайну;
- Поставка специализированных компонентов (Xilinx, Altera, Analog Devices, Intersil, Interpoint, Microsemi, Aeroflex, Peregrine, Syfer, Eurofarad, Texas Instrument, Miteq, Cobham, E2V, MA-COM, Hittite, Mini-Circuits, General Dynamics и др.);

Помимо этого, одним из направлений компании «ЭлектроПласт» является направление «Источники питания». Мы предлагаем Вам помощь Конструкторского отдела:

- Подбор оптимального решения, техническое обоснование при выборе компонента;
- Подбор аналогов;
- Консультации по применению компонента;
- Поставка образцов и прототипов;
- Техническая поддержка проекта;
- Защита от снятия компонента с производства.



#### Как с нами связаться

**Телефон:** 8 (812) 309 58 32 (многоканальный)

**Факс:** 8 (812) 320-02-42

**Электронная почта:** [org@eplast1.ru](mailto:org@eplast1.ru)

**Адрес:** 198099, г. Санкт-Петербург, ул. Калинина, дом 2, корпус 4, литера А.