

PCA2003

32 kHz watch circuit with programmable adaptive motor pulse and pulse period

Rev. 5 — 1 May 2019

Product data sheet

1. General description

The PCA2003 is a CMOS integrated circuit for battery operated wrist watches with a 32 kHz quartz crystal as timing element and a bipolar 1 Hz stepping motor. The quartz crystal oscillator and the frequency divider are optimized for minimum power consumption. A timing accuracy of 1 ppm is achieved with a programmable, digital frequency adjustment.

To obtain the minimum overall power consumption for the watch, an automatic motor pulse adaptation function is provided. The circuit supplies only the minimum drive current, which is necessary to ensure a correct motor step. Changing the drive current of the motor is achieved by chopping the motor pulse with a variable duty cycle. The pulse period and the range of the variable duty cycle can be programmed to suit different types of motors. The automatic pulse adaptation scheme is based on a safe dynamic detection of successful motor steps.

A pad RESET is provided (used for stopping the motor) for accurate time setting and for accelerated testing of the watch.

2. Features and benefits

- Amplitude-regulated 32 kHz quartz crystal oscillator, with excellent frequency stability and high immunity to leakage currents
- Electrically programmable time calibration with 1 ppm resolution stored in One Time Programmable (OTP) memory
- The quartz crystal is the only external component connected
- Very low supply current, typical 90 nA
- One second output pulses for bipolar stepping motor
- Five different programmable output periods (1 s to 30 s)
- Minimum power consumption for the entire watch, due to self adaptation of the motor drive according to the required torque
- Reliable step detection circuit
- Motor pulse width, pulse modulation, and pulse adaptation range programmable in a wide range, stored in OTP memory
- Stop function for accurate time setting and power saving during shelf life
- Test mode for accelerated testing of the mechanical parts of the watch and the IC
- Test bits for type recognition



6. Pinning information

6.1 Pinning

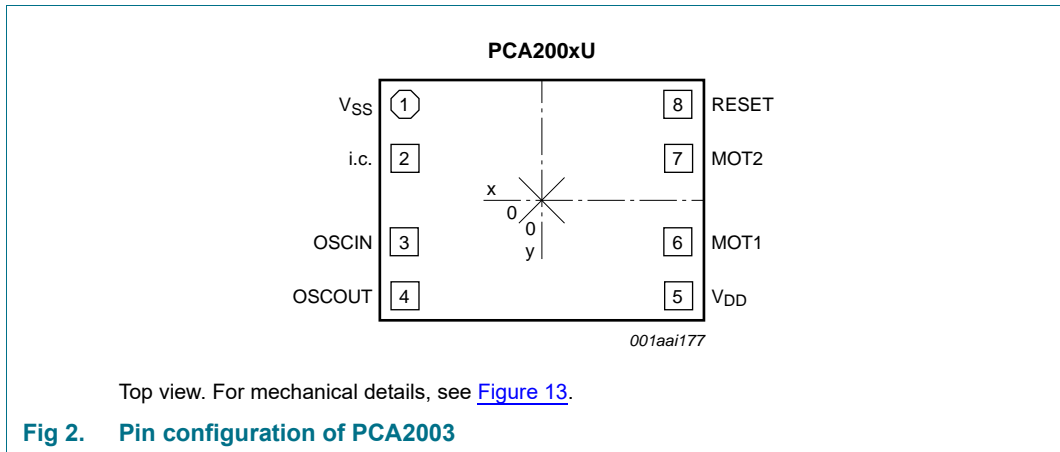

6.2 Pin description

Table 3. Pin description

Symbol	Pin	Description
V _{SS}	1	ground
i.c.	2	internally connected
OSCIN	3	oscillator input
OSCOUT	4	oscillator output
V _{DD}	5	supply voltage
MOT1	6	motor 1 output
MOT2	7	motor 2 output
RESET	8	reset input

7. Functional description

7.1 Motor pulse

The motor output supplies pulses of different driving stages, depending on the torque required to turn on the motor. The number of different stages can be selected between three and six. With the exception of the highest driving stage, each motor pulse (t_p in [Figure 3](#) and [Figure 6](#)) is followed by a detection phase during which the motor movement is monitored, in order to check whether the motor has turned correctly or not.

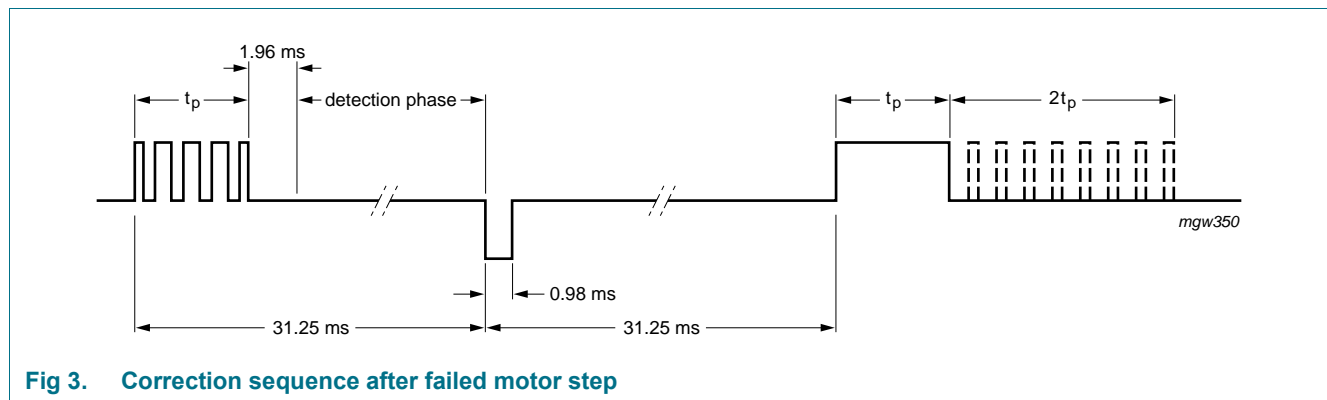

Fig 3. Correction sequence after failed motor step

If a missing step is detected, a correction sequence is generated (see [Figure 3](#)) and the driving stage is switched to the next level. The correction sequence consists of two pulses: first a short pulse in the opposite direction (0.98 ms, modulated with the maximum duty cycle) to give the motor a defined position, followed by a motor pulse of the strongest driving level. Every 4 minutes, the driving level is lowered again by one stage.

The motor pulse has a constant pulse width. The driving level is regulated by chopping the driving pulse with a variable duty cycle. The driving level starts from the programmed minimum value and increases by 6.25 % after each failed motor step. The strongest driving stage, which is not followed by a detection phase, is programmed separately.

Therefore, it is possible to program a larger energy gap between the pulses with step detection and the strongest, not monitored, pulse. This might be necessary to ensure a reliable and stable operation under adverse conditions (magnetic fields and vibrations). If the watch works in the highest driving stage, the driving level jumps after the 4-minute period directly to the lowest stage, and not just one stage lower.

To optimize the performance for different motors, the following parameters can be programmed:

- Pulse width: 0.98 ms to 7.8 ms in steps of 0.98 ms
- Duty cycle of lowest driving level: 37.5 % to 56.25 % in steps of 6.25 %
- Number of driving levels (including the highest driving level): 3 to 6
- Duty cycle of the highest driving level: 75 % or 100 %
- Enlargement pulse for the highest driving level: on or off

The enlargement pulse has a duty cycle of 25 % and a pulse width which is twice the programmed motor pulse width. The repetition period for the chopping pattern is 0.98 ms. [Figure 4](#) shows an example of a 3.9 ms pulse.

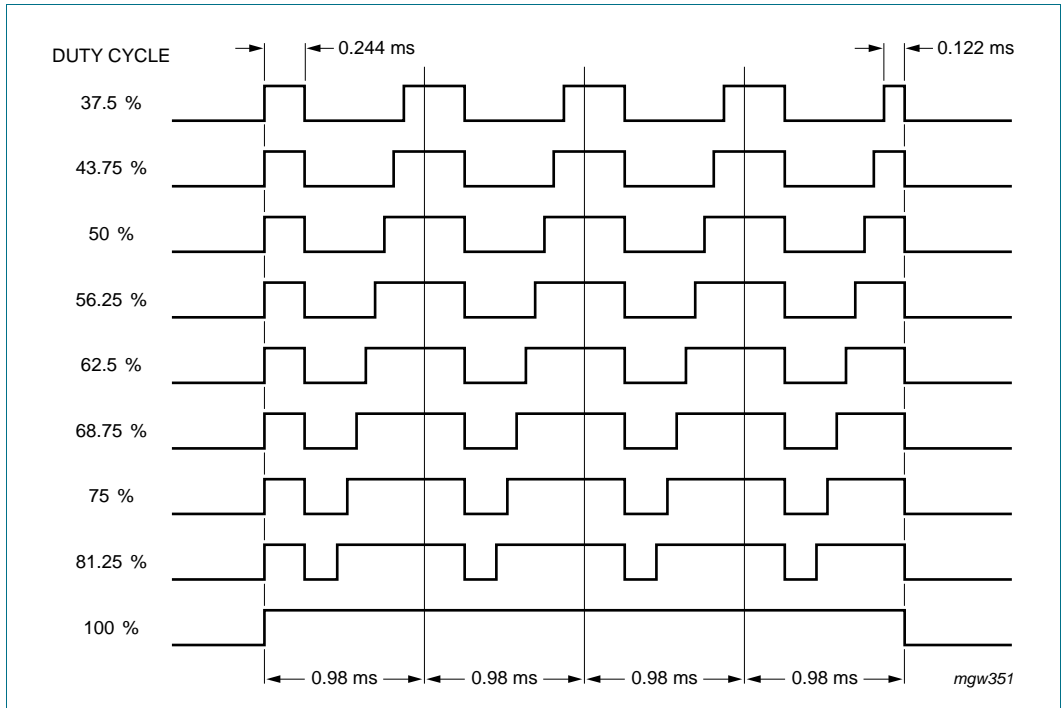

Fig 4. Possible modulations for a 3.9 ms motor pulse

7.2 Step detection

Figure 5 shows a simplified diagram of the motor driving and step detection circuit, and Figure 6 shows the step detection sequence and corresponding sampling current. Between the motor driving pulses, the switches P1 and P2 are closed, which means the motor is short-circuited. For a pulse in one direction, P1 and N2 are open, and P2 and N1 are closed with the appropriate duty cycle; for a pulse in the opposite direction, P2 and N1 are open, and P1 and N2 closed.

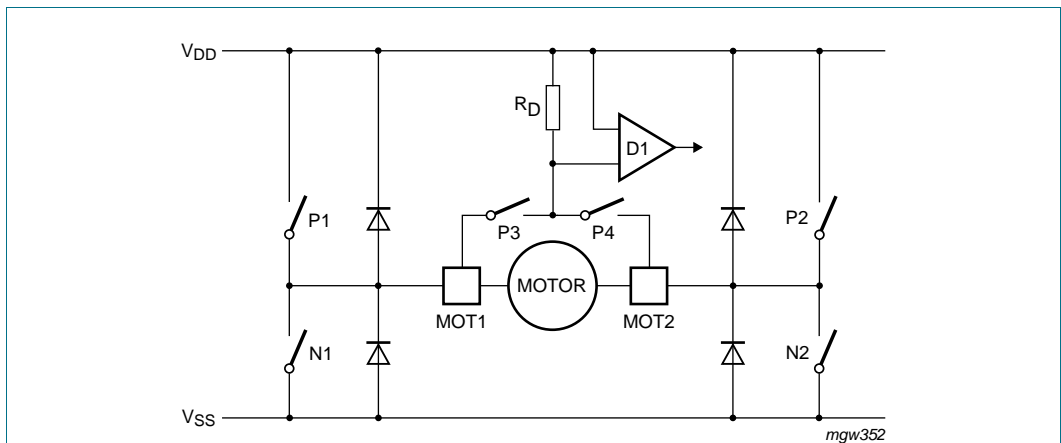

Fig 5. Simplified diagram of motor driving and step detection circuit

The step detection phase is initiated after the motor driving pulse. In phase 1 P1 and P2 are first closed for 0.98 ms and then in phase 2 all four drive switches (P1, N1, P2 and N2) are opened for 0.98 ms. As a result, the energy stored in the motor inductance is reduced as fast as possible.

The induced current caused by the residual motor movement is then sampled in phase 3 (closing P3 and P2) and in phase 4 (closing P1 and P4). For step detection in the opposite direction P1 and P4 are closed during phase 3 and P2 and P3 during phase 4 (see [Figure 6](#)).

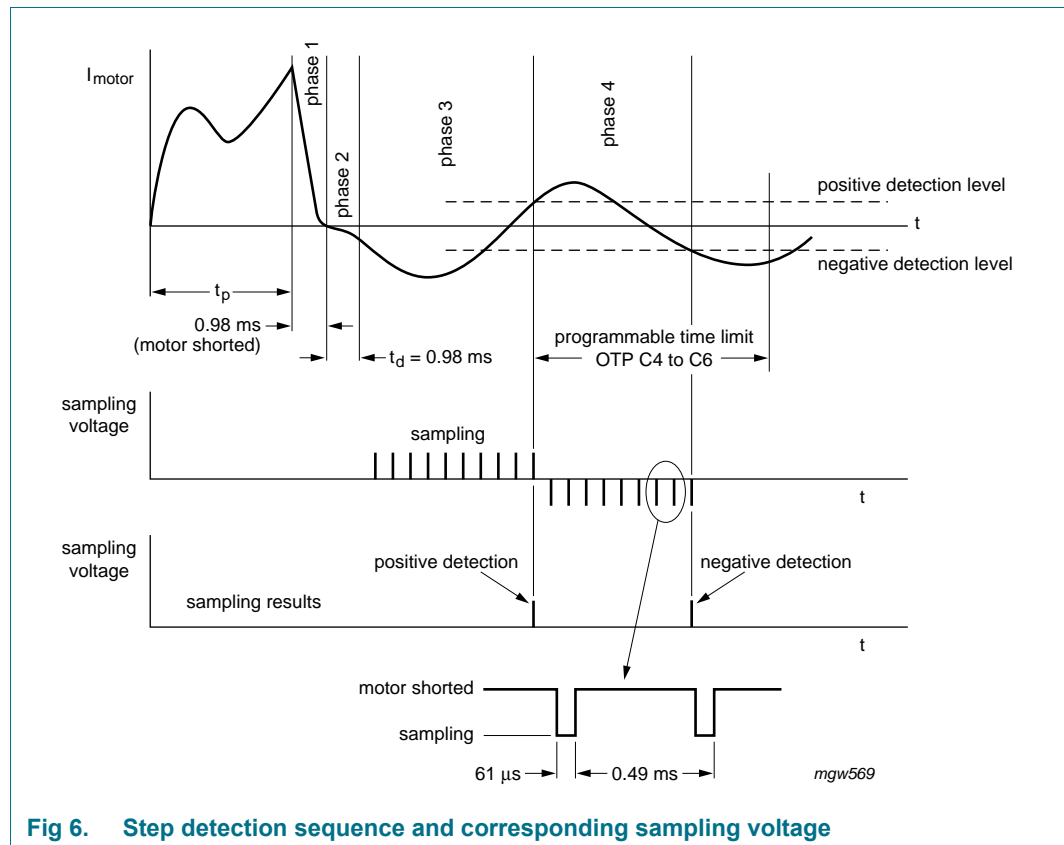

Fig 6. Step detection sequence and corresponding sampling voltage

The condition for a successful motor step is a positive step detection pulse (current in the same direction as in the driving phase) followed by a negative detection pulse within a given time limit. This time limit can be programmed between 3.9 ms and 10.7 ms (in steps of 0.98 ms) in order to ensure a safe and correct step detection under all conditions (for instance magnetic fields). The step detection phase stops after the last 31.25 ms, after the start of the motor driving pulse.

7.3 Time calibration

The quartz crystal oscillator has an integrated capacitance of 5.2 pF, which is lower than the specified capacitance (C_L) of 8.2 pF for the quartz crystal (see [Table 11](#)). Therefore, the oscillator frequency is typically 60 ppm higher than 32.768 kHz. This positive frequency offset is compensated by removing the appropriate number of 8192 Hz pulses in the divider chain (maximum 127 pulses), every 1 or 2 minutes. The time correction is given in [Table 4](#).

Table 4. Time calibration

Calibration period	Correction per step (n = 1)		Correction per step (n = 127)	
	ppm	Seconds per day	ppm	Seconds per day
1 minute	2.03	0.176	258	22.3
2 minutes	1.017	0.088	129	11.15

After measuring the effective oscillator frequency, the number of correction pulses must be calculated and stored together with the calibration period in the OTP memory (see [Section 7.7](#)).

The oscillator frequency can be measured at pad RESET, where a square wave signal with the frequency of $\frac{1}{1024} \times f_{osc}$ is provided. This frequency shows a jitter every minute or every two minutes, which originates from the time calibration, depending on the programmed calibration period.

Details on how to measure the oscillator frequency and the programmed inhibition time are given in [Section 7.10](#).

7.4 Reset

At pad RESET an output signal with a frequency of $\frac{1}{1024} \times f_{osc} = 32 \text{ Hz}$ is provided.

Connecting pad RESET to V_{DD} stops the motor drive and opens all four (P1, N1, P2 and N2) driver switches (see [Figure 5](#)). Connecting pad RESET to V_{SS} activates the test mode. In this mode the motor output frequency is 32 Hz, which can be used to test the mechanical function of the watch.

After releasing the pad RESET, the motor starts exactly one second later with the smallest duty cycle and with the opposite polarity to the last pulse before stopping. The debounce time for the RESET function is between 31 ms and 62 ms.

7.5 Programming possibilities

The programming data is stored in OTP cells (EPROM cells). At delivery, all memory cells are in state 0. The cells can be programmed to the state 1, but then there is no more set back to state 0. The programming data is organized in an array of four 8-bit words (see [Table 5](#)): word A contains the time calibration, words B and C contain the setting for the monitor pulses and word D contains the type recognition.

Table 5. Words and bits

Word	Bit							
	1	2	3	4	5	6	7	8
A	number of 8192 Hz pulses to be removed							calibration period
B	lowest stage: duty cycle		number of driving stages		highest stage: duty cycle	pulse stretching	output period	
C	pulse width			maximum time delay between positive and negative detection pulses			output period	factory test bit
D	type				factory test bits			

Table 6. Description of word A bits

Bit	Value	Description
Inhibition time		
1 to 7	-	adjust the number of the 8 192 Hz pulses to be removed; bit 1 is the MSB and bit 7 is the LSB
Calibration period		
8	0	1 minute
	1	2 minutes

Table 7. Description of word B bits

Bit	Value	Description
Duty cycle lowest driving stage		
1 to 2	00	37.5 %
	01	43.75 %
	10	50 %
	11	56.25 %
Number of driving stages		
3 to 4	00	3
	01	4
	10	5
	11	6 ^[1]
Duty cycle highest driving stage		
5	0	75 % ^[2]
	1	100 %
Pulse stretching		
6	0	no pulse stretching
	1	pulse of $2 \times t_p$ and duty cycle of 25 % are added
Output period		
7 to 8	00	1 s
	01	5 s
	10	10 s
	11	20 s

[1] Including the highest driving stage, which one has no motor step detection.

[2] If the maximum duty cycle of 75 % is selected, not all programming combinations are possible since the second highest level must be smaller than the highest driving level.

Table 8. Description of word C bits

Bit	Value	Description
Pulse width t_p		
1 to 3	000	0.98 ms
	001	1.95 ms
	010	2.90 ms
	011	3.90 ms
	100	4.90 ms
	101	5.90 ms
	110	6.80 ms
	111	7.80 ms
Time delay $t_{d(max)}$ [1]		
4 to 6	000	3.91 ms
	001	4.88 ms
	010	5.86 ms
	011	6.84 ms
	100	7.81 ms
	101	8.79 ms
	110	9.77 ms
	111	10.74 ms
Output period		
7	0	bit 7 and 8 of word B active
	1	30 s, bit 7 and 8 of word B inactive
Factory test bit		
8	-	-

[1] Between positive and negative detection pulses.

Byte D is read to determine which type of the PCA200x family is used in a particular application.

Table 9. Description of word D bits

Bit	Value	Description
Type recognition		
1 to 4	0000	PCA2002
	1000	PCA2000
	0100	PCA2001
	1100	PCA2003
Factory test bits		
5 to 8	-	-

7.6 Programming procedure

For a watch it is essential that the timing calibration can be made after the watch is fully assembled. In this situation, the supply pads are often the only terminals which are still accessible.

Writing to the OTP cells and performing the related functional checks is achieved in the PCA2003 by modulating the supply voltage. The necessary control circuit consists basically of a voltage level detector, an instruction counter which determines the function to be performed, and an 8-bit shift register which allows writing to the OTP cells of an 8-bit word in one step and acts as a data pointer for checking the OTP content.

There are six different instruction states (state 3 and state 5 are handled as state 4):

- State 1: measurement of the quartz crystal oscillator frequency (divided by 1024)
- State 2: measurement of the inhibition time
- State 3: write/check word A
- State 4: write/check word B
- State 5: write/check word C
- State 6: check word D (type recognition)

Each instruction state is switched on with a pulse to $V_{P(prog)(start)}$. After this large pulse, an initial waiting time of t_0 is required. The programming instructions are then entered by modulating the supply voltage with small pulses (amplitude $V_{P(mod)}$ and pulse width t_{mod}). The first small pulse defines the start time, the following pulses perform three different functions, depending on the time delay (t_d) from the preceding pulse (see [Figure 7](#), [Figure 8](#), [Figure 11](#) and [Figure 12](#)):

- $t_d = t_1$ (0.7 ms); increments the instruction counter
- $t_d = t_2$ (1.7 ms); clocks the shift register with data = logic 0
- $t_d = t_3$ (2.7 ms); clocks the shift register with data = logic 1

The programming procedure requires a stable oscillator. This means that a waiting time, determined by the start-up time of the oscillator is necessary after power-on of the circuit.

After the $V_{P(prog)(start)}$ pulse, the instruction counter is in state 1 and the data shift register is cleared.

The instruction state ends with a second pulse to $V_{P(prog)(stop)}$ or with a pulse to V_{store} .

In any case, the instruction states are terminated automatically 2 seconds after the last supply modulation pulse.

7.7 Programming the memory cells

Applying the two-stage programming pulse (see [Figure 7](#)) transfers the stored data in the shift register to the OTP cells.

Perform the following to program a memory word:

1. Starting with a $V_{P(prog)(start)}$ pulse wait for the time period t_0 then set the instruction counter to the word to be written ($t_d = t_1$).

2. Enter the data to be stored in the shift register ($t_d = t_2$ or t_3). LSB first (bit 8) and the MSB last (bit 1).
3. Applying the two-stage programming pulse $V_{prestore}$ followed by V_{store} stores the word. The delay between the last data bit and the prestore pulse $V_{prestore}$ is $t_d = t_4$. Store the word by raising the supply voltage to V_{store} ; the delay between the last data bit and the store pulse is t_d .

The example shown in [Figure 7](#) performs the following functions:

- Start
- Setting instruction counter to state 4 (word B)
- Entering data word 110101 into the shift register (sequence: LSB first and MSB last)
- Writing to the OTP cells for word B

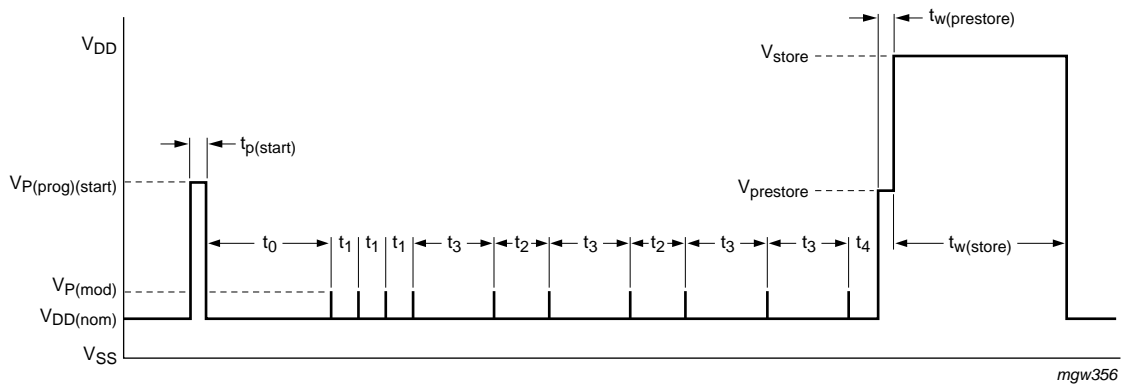

$V_{DD(nom)}$: nominal supply voltage.

The example shows the programming of B = 110101 (the sequence is MSB first and LSB last).

Fig 7. Supply voltage modulation for programming

7.8 Checking memory content

The stored data of the OTP array can be checked bit wise by measuring the supply current. The array word is selected by the instruction state and the bit is addressed by the shift register.

To read a word, the word is first selected ($t_d = t_1$), and a logic 1 is written into the first cell of the shift register ($t_d = t_3$). This logic 1 is then shifted through the entire shift register ($t_d = t_2$), so that it points with each clock pulse to the next bit.

If the addressed OTP cell contains a logic 1, a 30 kΩ resistor is connected between V_{DD} and V_{SS} , which increases the supply current accordingly.

Figure 8 shows the supply voltage modulation for reading word B, with the corresponding supply current variation for word B = 110101 (sequence: first MSB and last LSB).

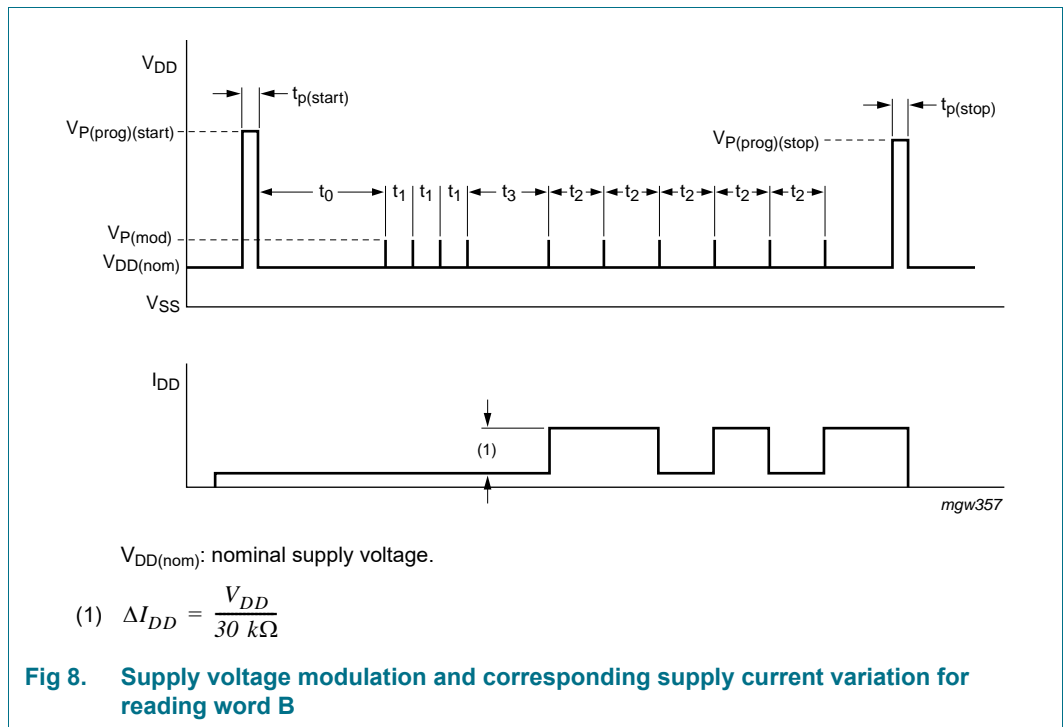

7.9 Frequency tuning of assembled watch

Figure 9 shows the test set-up for frequency tuning the assembled watch.

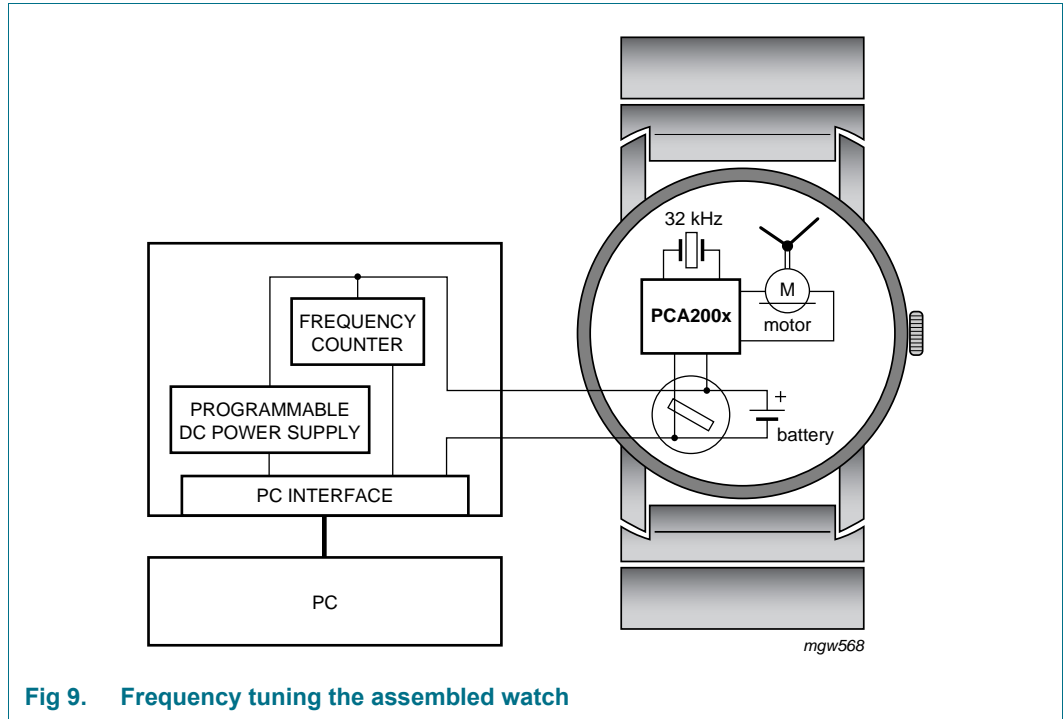

Fig 9. Frequency tuning the assembled watch

7.10 Measurement of oscillator frequency and inhibition time

The output of the two measuring states can either be monitored directly at pad RESET or as a modulation of the supply voltage (a modulating resistor of 30 kΩ is connected between V_{DD} and V_{SS} when the signal at pad RESET is at HIGH-level).

The supply voltage modulation must be followed as shown in Figure 10 in order to guarantee the correct start-up of the circuit during production and testing.

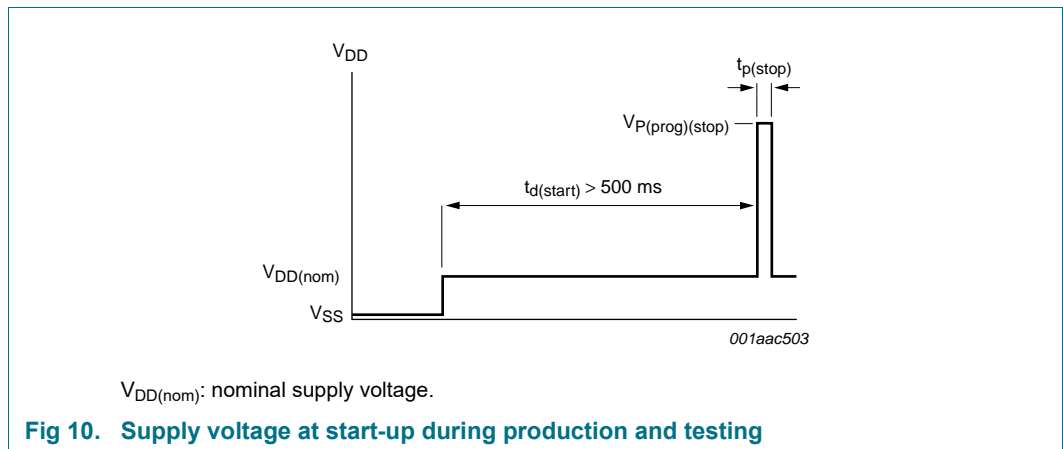

Fig 10. Supply voltage at start-up during production and testing

Measuring states:

- State 1: quartz crystal oscillator frequency divided by 1024; state 1 starts with a pulse to V_P and ends with a second pulse to V_P
- State 2: inhibition time has a value of $n \times 0.122$ ms. A signal with periodicity of 31.25 ms + $n \times 0.122$ ms appears at pad RESET and as current modulation at pad V_{DD} (see [Figure 11](#) and [Figure 12](#))

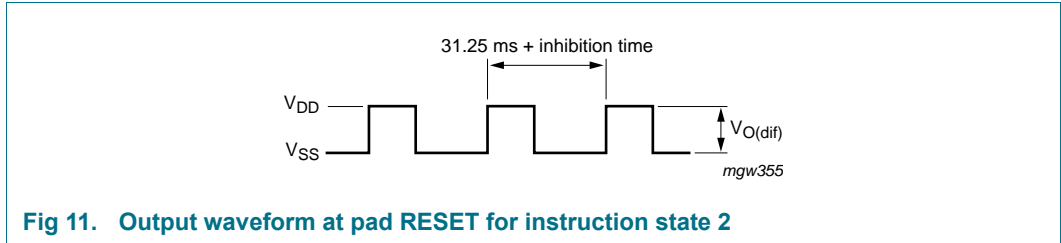

Fig 11. Output waveform at pad RESET for instruction state 2

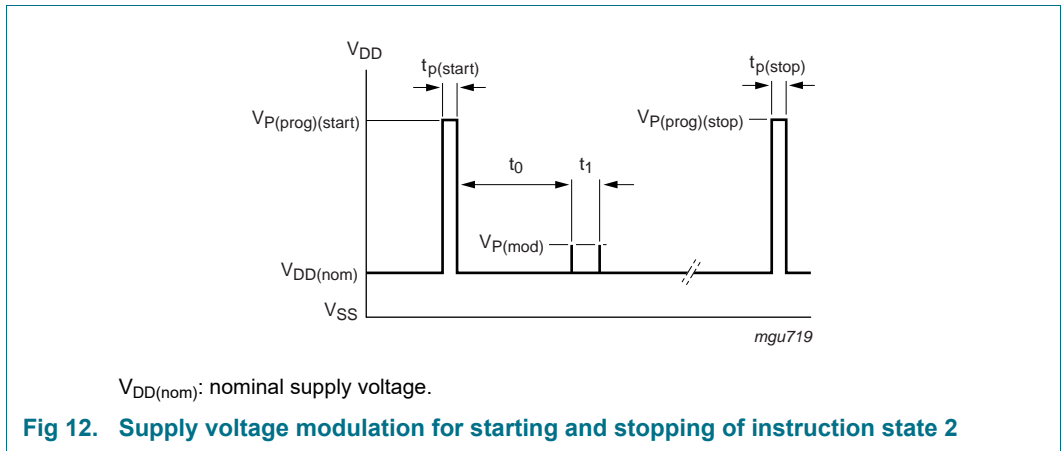

Fig 12. Supply voltage modulation for starting and stopping of instruction state 2

7.11 Customer testing

Connecting pad RESET to V_{SS} activates the test mode. In this test mode, the motor output frequency is 8 Hz; the duty cycle reduction and battery check occurs every second, instead of every 4 minutes.

8. Limiting values

Table 10. Limiting values

In accordance with the Absolute Maximum Rating System (IEC 60134).

Symbol	Parameter	Conditions	Min	Max	Unit
V_{DD}	supply voltage	$V_{SS} = 0\text{ V}$	[1][2] -1.8	+7.0	V
V_I	input voltage	on all supply pins	-0.5	+7.5	V
t_{sc}	short circuit duration time	output	-	indefinite	s
T_{amb}	ambient temperature		-10	+60	°C
V_{ESD}	electrostatic discharge voltage	HBM	[3] -	±2000	V
		MM	[4] -	±200	V
I_{lu}	latch-up current		[5] -	100	mA
T_{stg}	storage temperature		[6] -30	+100	°C

- [1] When writing to the OTP cells, the supply voltage (V_{DD}) can be raised to a maximum of 12 V for a time period of 1 s.
- [2] Connecting the battery with reversed polarity does not destroy the circuit, but in this condition a large current flows, which rapidly discharges the battery.
- [3] Pass level; Human Body Model (HBM), according to [Ref. 4 "JESD22-A114"](#).
- [4] Pass level; Machine Model (MM), according to [Ref. 5 "JESD22-A115"](#).
- [5] Pass level; latch-up testing according to [Ref. 6 "JESD78"](#) at maximum ambient temperature ($T_{amb(max)}$).
- [6] According to the NXP store and transport requirements (see [Ref. 8 "NX3-00092"](#)) the devices have to be stored at a temperature of +8 °C to +45 °C and a humidity of 25 % to 75 %. For long term storage products deviant conditions are described in that document.

9. Characteristics

Table 11. Characteristics

$V_{DD} = 1.55\text{ V}$; $V_{SS} = 0\text{ V}$; $f_{osc} = 32.768\text{ kHz}$; $T_{amb} = 25\text{ °C}$; quartz crystal: $R_S = 40\text{ k}\Omega$, $C_1 = 2\text{ fF to }3\text{ fF}$, $C_L = 8.2\text{ pF}$; unless otherwise specified.

Symbol	Parameter	Conditions	Min	Typ	Max	Unit	
Supply							
V_{DD}	supply voltage	normal operating mode; $T_{amb} = -10\text{ °C to }+60\text{ °C}$	1.1	1.55	3.60	V	
ΔV_{DD}	supply voltage variation	$\Delta V/\Delta t = 1\text{ V}/\mu\text{s}$	-	-	0.25	V	
I_{DD}	supply current	between motor pulses	-	90	120	nA	
		between motor pulses at $V_{DD} = 3.5\text{ V}$	-	120	180	nA	
		$T_{amb} = -10\text{ °C to }+60\text{ °C}$	-	-	200	nA	
		stop mode; pad RESET connected to V_{DD}	-	100	135	nA	
Motor output							
V_{sat}	saturation voltage	$R_{motor} = 2\text{ k}\Omega$; $T_{amb} = -10\text{ °C to }+60\text{ °C}$	[1]	-	150	200	mV
$Z_{o(sc)}$	output impedance (short circuit)	between motor pulses; $I_{motor} < 1\text{ mA}$	-	200	300	Ω	
Oscillator							
V_{start}	start voltage		1.1	-	-	V	
g_m	transconductance	$V_{i(osc)} \leq 50\text{ mV (p-p)}$	5	10	-	μS	
$t_{startup}$	start-up time		-	0.3	0.9	s	
$\Delta f/f$	frequency stability	$\Delta V_{DD} = 100\text{ mV}$	-	0.05	0.20	ppm	
$C_{L(itg)}$	integrated load capacitance		4.3	5.2	6.3	pF	
R_{par}	parasitic resistance	allowed resistance between adjacent pads	20	-	-	$\text{M}\Omega$	
Pad RESET							
f_o	output frequency		-	32	-	Hz	
$V_{O(dif)}$	differential output voltage	$R_L = 1\text{ M}\Omega$; $C_L = 10\text{ pF}$	[2]	1.4	-	V	
t_r	rise time	$R_L = 1\text{ M}\Omega$; $C_L = 10\text{ pF}$	[2]	-	1	μs	
t_f	fall time	$R_L = 1\text{ M}\Omega$; $C_L = 10\text{ pF}$	[2]	-	1	μs	
$I_{i(AV)}$	average input current	pad RESET connected to V_{DD} or V_{SS}	-	10	20	nA	

[1] $P1 + \dots + P4 + N1 + N2$ (see [Section 7.2](#)).

[2] R_L and C_L are a load resistor and load capacitor, externally connected to pad RESET.

10. OTP programming characteristics

Table 12. Specifications for OTP programming

See [Figure 7](#), [Figure 8](#) and [Figure 12](#).

Symbol	Parameter ^[1]	Conditions	Min	Typ	Max	Unit
V_{DD}	supply voltage	during programming procedure	1.5	-	3.0	V
$V_{P(prog)(start)}$	programming supply voltage (start)		6.6	-	6.8	V
$V_{P(prog)(stop)}$	programming supply voltage (stop)		6.2	-	6.4	V
$V_{P(mod)}$	supply voltage modulation	for entering instructions, referred to V_{DD}	320	350	380	mV
$V_{prestore}$	prestore voltage	for prestore pulse	6.2	-	6.4	V
V_{store}	store voltage	for writing to the OTP cells	9.9	10.0	10.1	V
I_{store}	store current	for writing to the OTP cells	-	-	10	mA
$t_{p(start)}$	start pulse width		8	10	12	ms
$t_{p(stop)}$	pulse width of stop pulse		0.05	-	0.5	ms
t_{mod}	modulation pulse width		25	30	40	μ s
$t_{w(prestore)}$	prestore pulse width		0.05	-	0.5	ms
$t_{w(store)}$	store pulse width	for writing to the OTP cells	95	100	110	ms
t_0	time 0	waiting time after start pulse	20	-	30	ms
t_1	time 1	pulse distance for incrementing the state counter	0.6	0.7	0.8	ms
t_2	time 2	pulse distance for clocking the data register with data = logic 0	1.6	1.7	1.8	ms
t_3	time 3	pulse distance for clocking the data register with data = logic 1	2.6	2.7	2.8	ms
t_4	time 4	waiting time for writing to OTP cells	0.1	0.2	0.3	ms
SR	slew rate	for modulation of the supply voltage	0.5	-	5.0	V/ μ s
R_{mod}	modulation resistance	supply current modulation read-out resistor	18	30	45	k Ω

[1] Program each word once only.

11. Bare die outline

Wire bond die; 8 bonding pads

PCA200xU

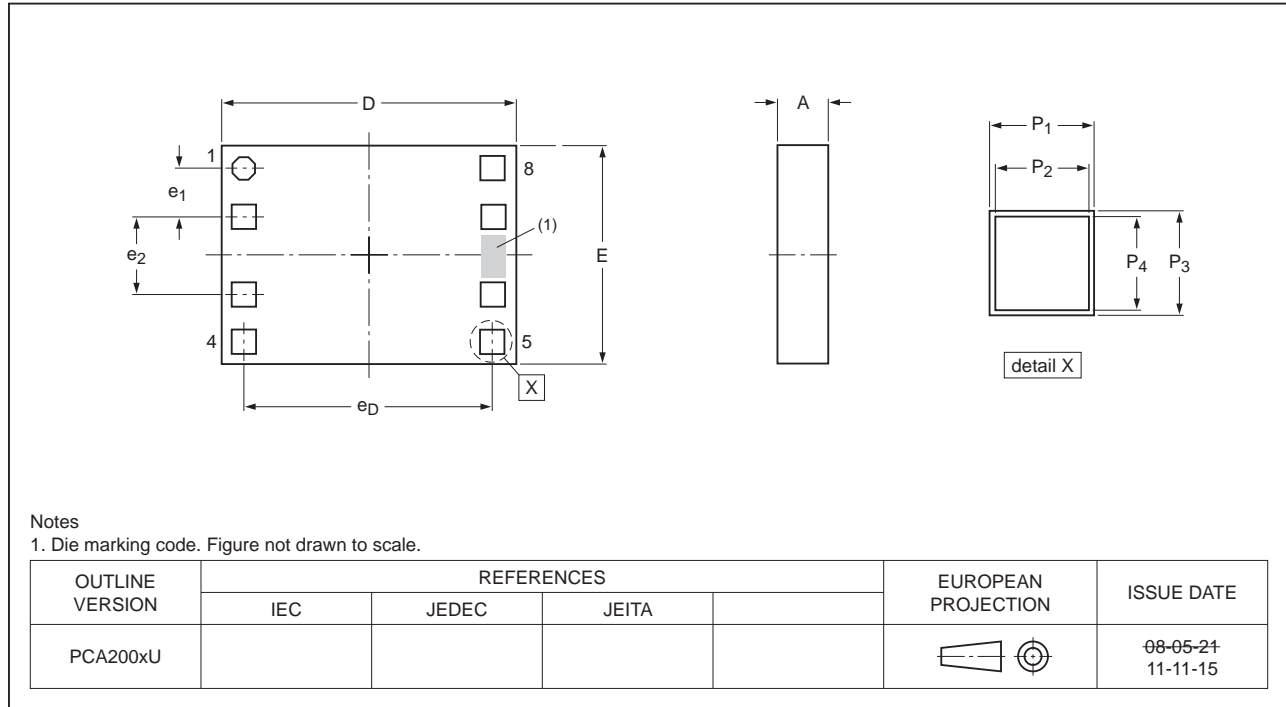

Fig 13. Bare die outline of PCA2003U (for dimensions see [Table 13](#), for pin location see [Table 14](#))

Table 13. Dimensions of PCA2003U

Original dimensions are in mm.

Unit (mm)	A	D	E	e ₁	e ₂	e _D	P ₁	P ₂	P ₃	P ₄
max	0.22	-	-	-	-	-	0.099	0.089	0.099	0.089
nom	0.20	1.16	0.86	0.17	0.32	0.96	0.096	0.086	0.096	0.086
min	0.18	-	-	-	-	-	0.093	0.083	0.093	0.083

Table 14. Bonding pad description

Symbol	Pin	X ^[1]	Y ^[1]	Type	Description
V _{SS} ^[2]	1	-480	+330	supply	ground
i.c. ^[3]	2	-480	+160	-	internally connected
OSCIN	3	-480	-160	input	oscillator input
OSCOUT	4	-480	-330	output	oscillator output
V _{DD}	5	+480	-330	supply	supply voltage
MOT1	6	+480	-160	output	motor 1 output
MOT2	7	+480	+160	output	motor 2 output
RESET	8	+480	+330	input	reset input

[1] All coordinates are referenced, in μm , to the center of the die (see [Figure 13](#)).

[2] The substrate (rear side of the chip) is connected to V_{SS}. Therefore the die pad must be either floating or connected to V_{SS}.

[3] Pad i.c. is used for factory tests; in normal operation it should be left open-circuit, and it has an internal pull-down resistance to V_{SS}.

12. Abbreviations

Table 15. Abbreviations

Acronym	Description
CMOS	Complementary Metal Oxide Semiconductor
HBM	Human Body Model
LSB	Least Significant Bit
MM	Machine Model
MSB	Most Significant Bit
OTP	One Time Programmable

13. References

- [1] **AN10706** — Handling bare die
- [2] **IEC 60134** — Rating systems for electronic tubes and valves and analogous semiconductor devices
- [3] **IEC 61340-5** — Protection of electronic devices from electrostatic phenomena
- [4] **JESD22-A114** — Electrostatic Discharge (ESD) Sensitivity Testing Human Body Model (HBM)
- [5] **JESD22-A115** — Electrostatic Discharge (ESD) Sensitivity Testing Machine Model (MM)
- [6] **JESD78** — IC Latch-Up Test
- [7] **JESD625-A** — Requirements for Handling Electrostatic-Discharge-Sensitive (ESDS) Devices
- [8] **NX3-00092** — NXP store and transport requirements

14. Revision history

Table 16. Revision history

Document ID	Release date	Data sheet status	Change notice	Supersedes
PCA2003 v.5	20190501	Product data sheet	-	PCA2003 v.4
Modifications:	<ul style="list-style-type: none"> • Added PCA2003U/10AC/1Z 			
PCA2003 v.4	20111125	Product data sheet	-	PCA2003_3
Modifications:	<ul style="list-style-type: none"> • Added die marking information 			
PCA2003_3	20100507	Product data sheet	-	PCA2003_2
PCA2003_2	20090721	Product data sheet	-	PCA2003_1
PCA2003_1	20081215	Product data sheet	-	-

15. Legal information

15.1 Data sheet status

Document status ^{[1][2]}	Product status ^[3]	Definition
Objective [short] data sheet	Development	This document contains data from the objective specification for product development.
Preliminary [short] data sheet	Qualification	This document contains data from the preliminary specification.
Product [short] data sheet	Production	This document contains the product specification.

[1] Please consult the most recently issued document before initiating or completing a design.

[2] The term 'short data sheet' is explained in section "Definitions".

[3] The product status of device(s) described in this document may have changed since this document was published and may differ in case of multiple devices. The latest product status information is available on the Internet at URL <http://www.nxp.com>.

15.2 Definitions

Draft — The document is a draft version only. The content is still under internal review and subject to formal approval, which may result in modifications or additions. NXP Semiconductors does not give any representations or warranties as to the accuracy or completeness of information included herein and shall have no liability for the consequences of use of such information.

Short data sheet — A short data sheet is an extract from a full data sheet with the same product type number(s) and title. A short data sheet is intended for quick reference only and should not be relied upon to contain detailed and full information. For detailed and full information see the relevant full data sheet, which is available on request via the local NXP Semiconductors sales office. In case of any inconsistency or conflict with the short data sheet, the full data sheet shall prevail.

Product specification — The information and data provided in a Product data sheet shall define the specification of the product as agreed between NXP Semiconductors and its customer, unless NXP Semiconductors and customer have explicitly agreed otherwise in writing. In no event however, shall an agreement be valid in which the NXP Semiconductors product is deemed to offer functions and qualities beyond those described in the Product data sheet.

15.3 Disclaimers

Limited warranty and liability — Information in this document is believed to be accurate and reliable. However, NXP Semiconductors does not give any representations or warranties, expressed or implied, as to the accuracy or completeness of such information and shall have no liability for the consequences of use of such information. NXP Semiconductors takes no responsibility for the content in this document if provided by an information source outside of NXP Semiconductors.

In no event shall NXP Semiconductors be liable for any indirect, incidental, punitive, special or consequential damages (including - without limitation - lost profits, lost savings, business interruption, costs related to the removal or replacement of any products or rework charges) whether or not such damages are based on tort (including negligence), warranty, breach of contract or any other legal theory.

Notwithstanding any damages that customer might incur for any reason whatsoever, NXP Semiconductors' aggregate and cumulative liability towards customer for the products described herein shall be limited in accordance with the *Terms and conditions of commercial sale* of NXP Semiconductors.

Right to make changes — NXP Semiconductors reserves the right to make changes to information published in this document, including without limitation specifications and product descriptions, at any time and without notice. This document supersedes and replaces all information supplied prior to the publication hereof.

Suitability for use — NXP Semiconductors products are not designed, authorized or warranted to be suitable for use in life support, life-critical or safety-critical systems or equipment, nor in applications where failure or malfunction of an NXP Semiconductors product can reasonably be expected to result in personal injury, death or severe property or environmental damage. NXP Semiconductors and its suppliers accept no liability for inclusion and/or use of NXP Semiconductors products in such equipment or applications and therefore such inclusion and/or use is at the customer's own risk.

Applications — Applications that are described herein for any of these products are for illustrative purposes only. NXP Semiconductors makes no representation or warranty that such applications will be suitable for the specified use without further testing or modification.

Customers are responsible for the design and operation of their applications and products using NXP Semiconductors products, and NXP Semiconductors accepts no liability for any assistance with applications or customer product design. It is customer's sole responsibility to determine whether the NXP Semiconductors product is suitable and fit for the customer's applications and products planned, as well as for the planned application and use of customer's third party customer(s). Customers should provide appropriate design and operating safeguards to minimize the risks associated with their applications and products.

NXP Semiconductors does not accept any liability related to any default, damage, costs or problem which is based on any weakness or default in the customer's applications or products, or the application or use by customer's third party customer(s). Customer is responsible for doing all necessary testing for the customer's applications and products using NXP Semiconductors products in order to avoid a default of the applications and the products or of the application or use by customer's third party customer(s). NXP does not accept any liability in this respect.

Limiting values — Stress above one or more limiting values (as defined in the Absolute Maximum Ratings System of IEC 60134) will cause permanent damage to the device. Limiting values are stress ratings only and (proper) operation of the device at these or any other conditions above those given in the Recommended operating conditions section (if present) or the Characteristics sections of this document is not warranted. Constant or repeated exposure to limiting values will permanently and irreversibly affect the quality and reliability of the device.

Terms and conditions of commercial sale — NXP Semiconductors products are sold subject to the general terms and conditions of commercial sale, as published at <http://www.nxp.com/profile/terms>, unless otherwise agreed in a valid written individual agreement. In case an individual agreement is concluded only the terms and conditions of the respective agreement shall apply. NXP Semiconductors hereby expressly objects to applying the customer's general terms and conditions with regard to the purchase of NXP Semiconductors products by customer.

No offer to sell or license — Nothing in this document may be interpreted or construed as an offer to sell products that is open for acceptance or the grant, conveyance or implication of any license under any copyrights, patents or other industrial or intellectual property rights.

32 kHz watch circuit with programmable adaptive motor pulse

Export control — This document as well as the item(s) described herein may be subject to export control regulations. Export might require a prior authorization from competent authorities.

Non-automotive qualified products — Unless this data sheet expressly states that this specific NXP Semiconductors product is automotive qualified, the product is not suitable for automotive use. It is neither qualified nor tested in accordance with automotive testing or application requirements. NXP Semiconductors accepts no liability for inclusion and/or use of non-automotive qualified products in automotive equipment or applications.

In the event that customer uses the product for design-in and use in automotive applications to automotive specifications and standards, customer (a) shall use the product without NXP Semiconductors' warranty of the product for such automotive applications, use and specifications, and (b) whenever customer uses the product for automotive applications beyond NXP Semiconductors' specifications such use shall be solely at customer's own risk, and (c) customer fully indemnifies NXP Semiconductors for any liability, damages or failed product claims resulting from customer design and use of the product for automotive applications beyond NXP Semiconductors' standard warranty and NXP Semiconductors' product specifications.

Bare die — All die are tested on compliance with their related technical specifications as stated in this data sheet up to the point of wafer sawing and are handled in accordance with the NXP Semiconductors storage and transportation conditions. If there are data sheet limits not guaranteed, these will be separately indicated in the data sheet. There are no post-packing tests performed on individual die or wafers.

NXP Semiconductors has no control of third party procedures in the sawing, handling, packing or assembly of the die. Accordingly, NXP Semiconductors assumes no liability for device functionality or performance of the die or systems after third party sawing, handling, packing or assembly of the die. It is the responsibility of the customer to test and qualify their application in which the die is used.

All die sales are conditioned upon and subject to the customer entering into a written die sale agreement with NXP Semiconductors through its legal department.

15.4 Trademarks

Notice: All referenced brands, product names, service names and trademarks are the property of their respective owners.

16. Contact information

For more information, please visit: <http://www.nxp.com>

For sales office addresses, please send an email to: salesaddresses@nxp.com

17. Contents

1	General description	1
2	Features and benefits	1
3	Applications	2
4	Ordering information	2
5	Marking	2
6	Block diagram	2
7	Pinning information	3
7.1	Pinning	3
7.2	Pin description	3
8	Functional description	4
8.1	Motor pulse	4
8.2	Step detection	5
8.3	Time calibration	6
8.4	Reset	7
8.5	Programming possibilities	7
8.6	Programming procedure	10
8.7	Programming the memory cells	10
8.8	Checking memory content	12
8.9	Frequency tuning of assembled watch	13
8.10	Measurement of oscillator frequency and inhibition time	13
8.11	Customer testing	14
9	Limiting values	15
10	Characteristics	16
11	OTP programming characteristics	17
12	Bare die outline	18
13	Abbreviations	20
14	References	20
15	Revision history	20
16	Legal information	21
16.1	Data sheet status	21
16.2	Definitions	21
16.3	Disclaimers	21
16.4	Trademarks	22
17	Contact information	22
18	Contents	23

Please be aware that important notices concerning this document and the product(s) described herein, have been included in section 'Legal information'.

© NXP B.V. 2019.

All rights reserved.

For more information, please visit: <http://www.nxp.com>

For sales office addresses, please send an email to: salesaddresses@nxp.com

Date of release: 1 May 2019

Document identifier: PCA2003



Компания «ЭлектроПласт» предлагает заключение долгосрочных отношений при поставках импортных электронных компонентов на взаимовыгодных условиях!

Наши преимущества:

- Оперативные поставки широкого спектра электронных компонентов отечественного и импортного производства напрямую от производителей и с крупнейших мировых складов;
- Поставка более 17-ти миллионов наименований электронных компонентов;
- Поставка сложных, дефицитных, либо снятых с производства позиций;
- Оперативные сроки поставки под заказ (от 5 рабочих дней);
- Экспресс доставка в любую точку России;
- Техническая поддержка проекта, помощь в подборе аналогов, поставка прототипов;
- Система менеджмента качества сертифицирована по Международному стандарту ISO 9001;
- Лицензия ФСБ на осуществление работ с использованием сведений, составляющих государственную тайну;
- Поставка специализированных компонентов (Xilinx, Altera, Analog Devices, Intersil, Interpoint, Microsemi, Aeroflex, Peregrine, Syfer, Eurofarad, Texas Instrument, Miteq, Cobham, E2V, MA-COM, Hittite, Mini-Circuits, General Dynamics и др.);

Помимо этого, одним из направлений компании «ЭлектроПласт» является направление «Источники питания». Мы предлагаем Вам помощь Конструкторского отдела:

- Подбор оптимального решения, техническое обоснование при выборе компонента;
- Подбор аналогов;
- Консультации по применению компонента;
- Поставка образцов и прототипов;
- Техническая поддержка проекта;
- Защита от снятия компонента с производства.



Как с нами связаться

Телефон: 8 (812) 309 58 32 (многоканальный)

Факс: 8 (812) 320-02-42

Электронная почта: org@eplast1.ru

Адрес: 198099, г. Санкт-Петербург, ул. Калинина, дом 2, корпус 4, литера А.