

AS7620

650mA, Ultra low Ripple Step Down DC/DC Converter

1 General Description

The AS7620 is an easy-to-use, high-efficiency, high-voltage, hysteretic step-down DC-DC converter, operating in asynchronous mode. Its low-power architecture extends hold-up time in battery-backed and critical applications where maximum up-time over a wide input supply voltage range is needed, while still providing for high efficiencies of up to 90% during peak current demands.

Although the AS7620 is optimized for 24V applications found in industrial and medical systems, its ability to support 100% Duty Cycle makes the AS7620 ideal for applications demanding maximum up-time and soft power fail behavior. In combination with low idle current of only 30 μ A, on-demand switching reduces operating current at low load currents.

By selecting an appropriate inductor value, operating current can be lowered and switching frequencies tuned to certain load conditions.

A pin-strapped current limit input minimizes inductor peak current and thus inductor size and cost for any given application.

The device further includes output short-circuit protection and thermal shutdown. In shutdown mode, only 1 μ A (typ) of current is consumed.

2 Key Features

- Low quiescent current for efficient partial load operation
- Wide Supply Voltage Range, 3.6V to 32V
- 100% Duty Cycle extends operating range
- Pin-programmable cycle-by-cycle current limit
- Integrated PMOS eliminates bootstrap capacitor
- Resistor-programmable Early Power Fail Warning Input
- Power-Good Flag
- Thermal Shutdown
- Fixed 3.3V and adjustable output (1.2V to V_{IN})
- Small 4x4mm 12-Lead MLPQ Enhanced Power Package
- Specified from -40°C to +125°C junction and 85°C maximum ambient temperatures

3 Applications

The AS7620 is suitable for Industrial 24VDC applications like PLCs, robotics; Home Security and Building Control applications; Solid-state utility meters; Signage and LED column power; and Sensor interfaces.

Figure 1. AS7620 - Block Diagram

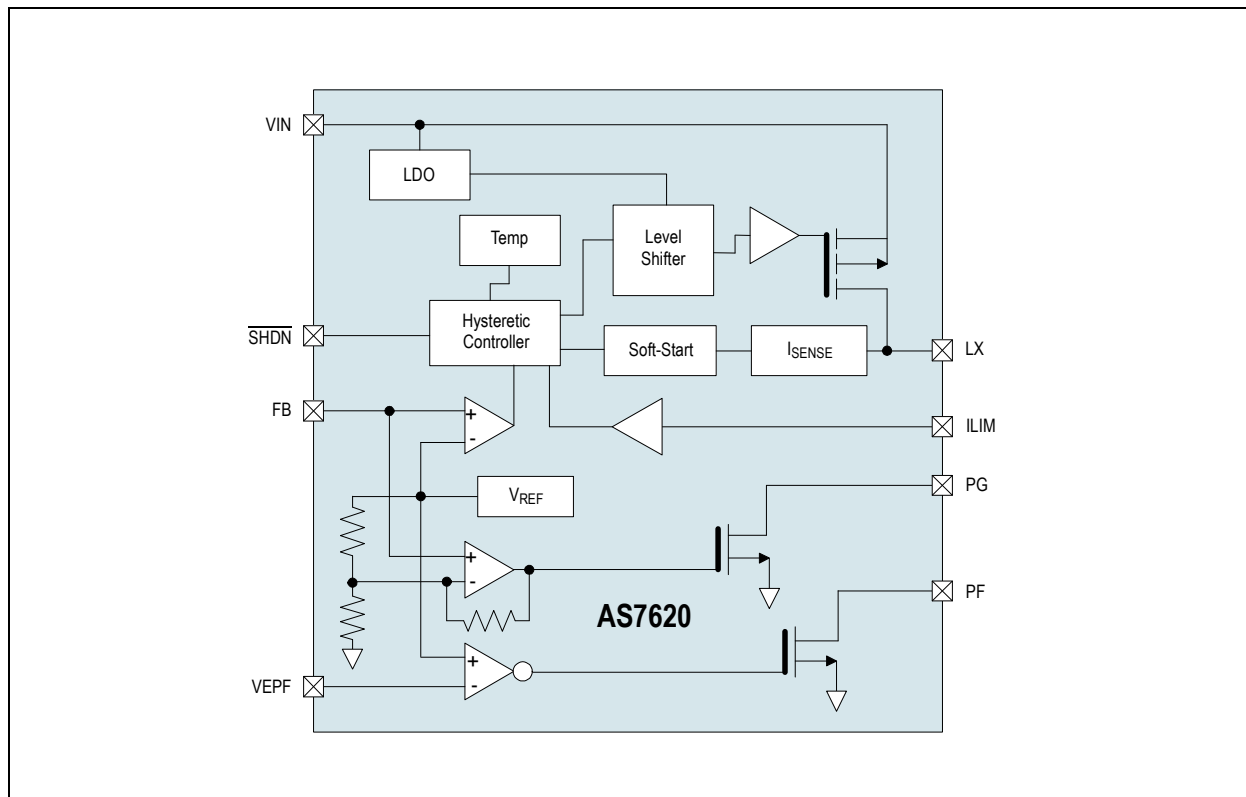



4 Pin Assignments

Figure 2. Pin Assignments (Top View)

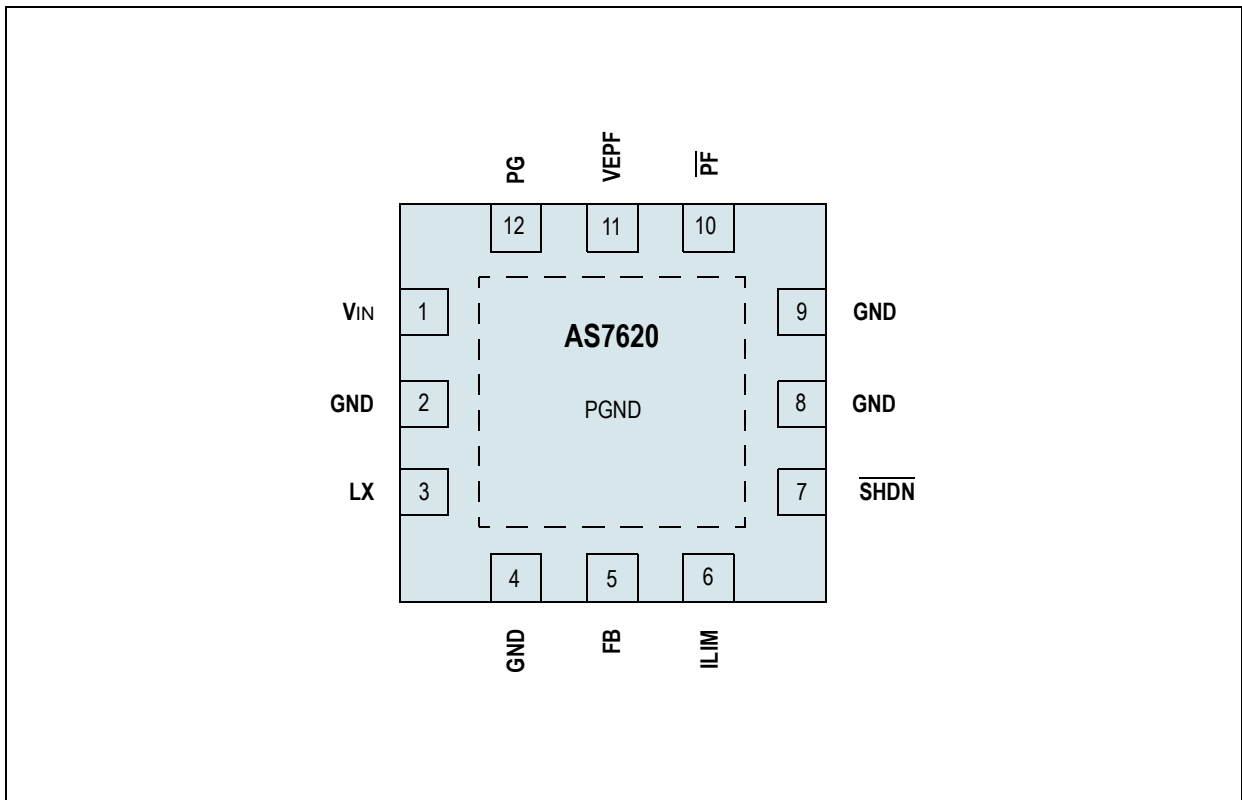

4.1 Pin Descriptions

Table 1. Pin Descriptions

Pin Number	Pin Name	Description
1	V _{IN}	High Voltage Power Supply Input
2	GND	Must be connected to GND
3	LX	Power Output to Inductor
4	GND	Must be connected to GND
5	FB	Feedback input
6	ILIM	Current Limit input
7	$\overline{\text{SHDN}}$	Shutdown input, active low
8	GND	Must be connected to GND
9	GND	Must be connected to GND
10	$\overline{\text{PF}}$	Early Power Fail output, open drain, active LOW
11	VEPF	Comparator voltage input for early power fail warning
12	PG	Power Good, open drain, active HIGH output, monitors feedback voltage
Pad	PGND	Exposed pad. Connect to GND plane to help thermal dissipation



5 Absolute Maximum Ratings

Stresses beyond those listed in [Table 2](#) may cause permanent damage to the device. These are stress ratings only, and functional operation of the device at these or any other conditions beyond those indicated in [Electrical Characteristics on page 4](#) is not implied. Exposure to absolute maximum rating conditions for extended periods may affect device reliability.

Table 2. Absolute Maximum Ratings

Parameter	Min	Max	Units	Comments
Electrical Parameters				
V _{IN}	-0.3	40	V	
LX	-0.3	V _{IN} +0.3	V	
FB, SHDN	-0.3	V _{IN} +0.3 or 5.5	V	Whichever is lower
All other pins except LX, FB and SHDN	-0.3	3.6	V	
Input Current (latch-up immunity)	-30	+30	mA	Norm: JEDEC 78 ¹
Electrostatic Discharge				
Electrostatic Discharge HBM		+/- 1	kV	Norm: MIL 883 E method 3015
Temperature Ranges and Storage Conditions				
Package Power Dissipation		1	W	θ _{JA} = 32°C/W for a 4-layer board, 4 vias, T _{AMB} = +70°C
Storage Temperature	-55	150	°C	
Junction Temperature		150	°C	
Package body temperature		260	°C	The reflow peak soldering temperature (body temperature) specified is in accordance with <i>IPC/JEDEC J-STD-020 "Moisture/Reflow Sensitivity Classification for Non-Hermetic Solid State Surface Mount Devices"</i> . The lead finish for Pb-free leaded packages is matte tin (100% Sn).
Humidity non-condensing	5	85	%	
Moisture Sensitive Level		3		Represents a max. floor life time of 168h

1. Voltage on pin 7 (SHDN) limited to +5.5V



6 Electrical Characteristics

$V_{OUT}=3.3V$, $L_X=10\mu H$, $C_X=100\mu F$, typical values at $V_{IN}=+24V$ and $T_{AMB}=+25^\circ C$ (unless otherwise specified). All limits are guaranteed. The parameters with min and max values are guaranteed with production tests or SQC (Statistical Quality Control) methods.

Table 3. Electrical Characteristics

Symbol	Parameter		Conditions	Min	Typ	Max	Units
T_{AMB}	Operating Temperature Range			-40		85	$^\circ C$
T_J	Operating Junction Temperature			-40		125	$^\circ C$
V_{IN}	Input Voltage Range			3.6	24	32	V
V_{CC}			VEPF, ILIM	-0.3		3.6	V
V_{ST}	Start-up Voltage			3.3			V
V_{OUT}	Output Voltage	AS7620-A		1.19		V_{IN}	V
		AS7620-B	Initial, at $25^\circ C$ amb.	3.267	3.300	3.333	V
			Over line, load and temperature	3.218		3.383	
V_{FB}	Feedback voltage	AS7620-A	Initial, at $25^\circ C$ amb.	1.178	1.190	1.202	V
			Over line and temperature	1.166		1.214	
		AS7620-B		3.218	3.300	3.383	
V_{HYS}	Controller Hysteresis	AS7620-A	At FB node	8	15	30	mV
		AS7620-B		22	42	82	
V_{EPF}	Early Power Fail Threshold		at V_{EPF}		1.19		V
V_{PG}	Power Good Threshold		of V_{FB} at FB pin	91	93	95	%
	Line Regulation		$V_{IN}=8V$ to $24V$, $R_L=200\Omega$		0.1		% / V
	Load Regulation		10% to 90% load change		0.9		%
I_{FB}	Input Bias Current	AS7620-A	FB pin			200	nA
		AS7620-B			3	5	μA
I_{OUT}	Output Current					$I_{LIM}/2$	mA
I_{LIM}	Switch Current Limit		$I_{LIM}=0V^1$	192	240	288	mA
			$I_{LIM}=V_{OUT}^2$	576	720	864	
			$I_{LIM}=\text{open}$	800	1000	1200	
	P-Channel on resistance				0.4	0.8	Ω
	Maximum Duty Cycle		At $V_{IN}=3.6V$			100	%
t_{ON}	Minimum On-Time		Current limit is not attained to turn off the switch before the minimum on-time expired	8	10	12	μs
t_{OFF}	Minimum Off-Time			0.22	0.42	0.62	μs
I_Q	Quiescent Current		Non-switching		30	45	μA
			$I_{OUT}=500\mu A$		37		μA
I_{SHDN}	Shutdown Current		$T_{AMB}=+25^\circ C$		1	5	μA
V_{LO}	Shutdown Threshold		SHDN			1	V
I_{IBN}	Logic Input Bias Current		SHDN			1	μA
T_{SHDN}	Shutdown Temperature				160		$^\circ C$
	T_{SHDN} Hysteresis				10		$^\circ C$

1. $L_X=100\mu H$, $C_X=10\mu F$, Initial accuracy only. For temperature variation, please refer to performance graphs.

2. V_{OUT} from 1.5V to 3.6V



7 Typical Operating Characteristics

Figure 3. Efficiency vs. Output Current, $V_{OUT}=4.5V$

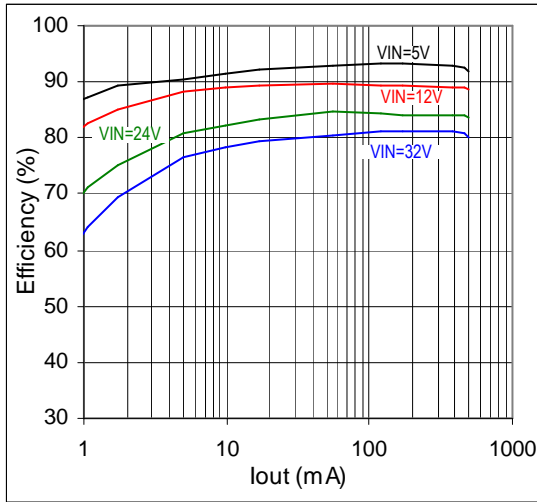

Figure 4. PMOS $R_{ds(on)}$ vs. Temperature

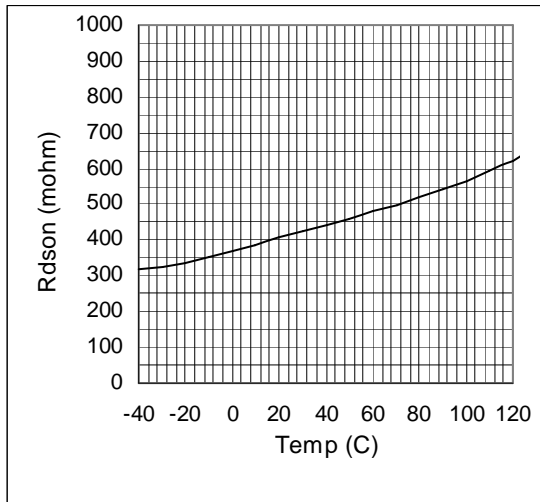

Figure 5. GND Current vs. I_{OUT} @ T_{AMB}

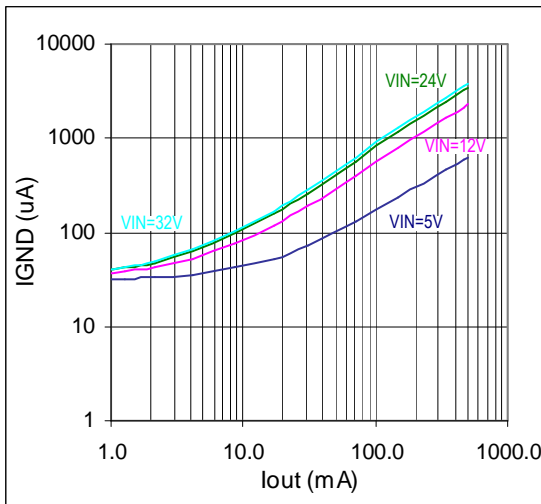

Figure 6. GND Current vs. Temperature @ $I_{OUT}=0A$

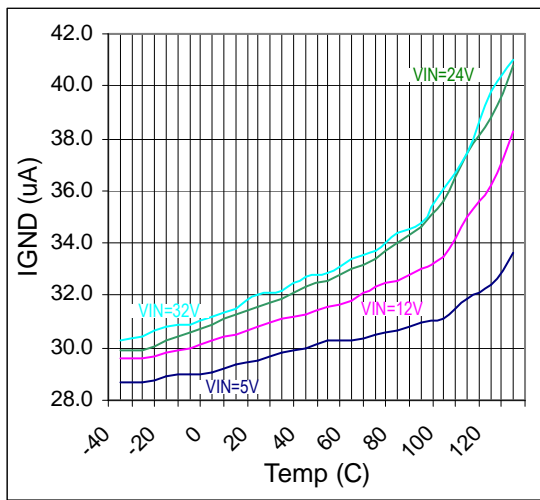



Figure 7. Current Limit Threshold vs. V_{in}

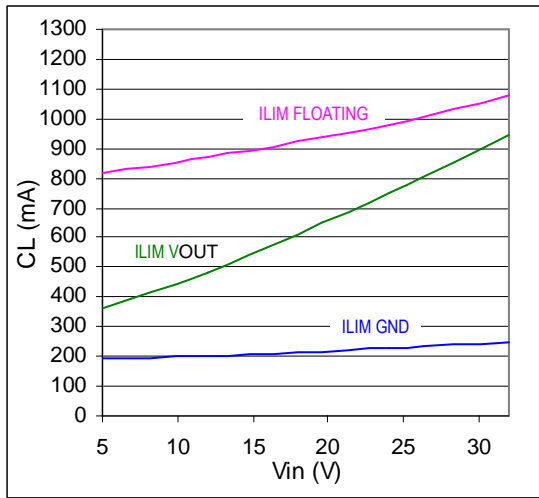

Figure 8. Average Switching Frequency vs. V_{in}

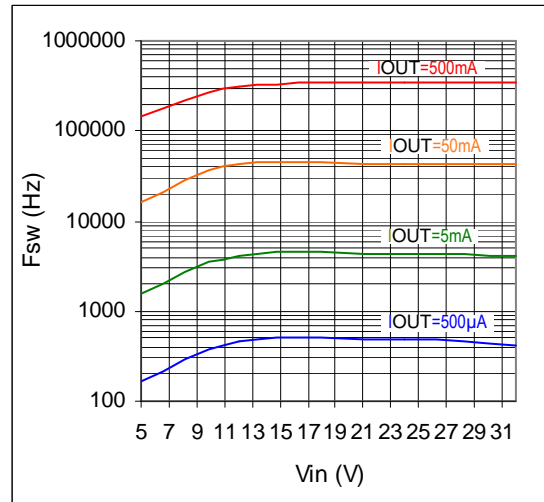

Figure 9. Average Switching Frequency vs. I_{OUT} ($ILIM=open$)

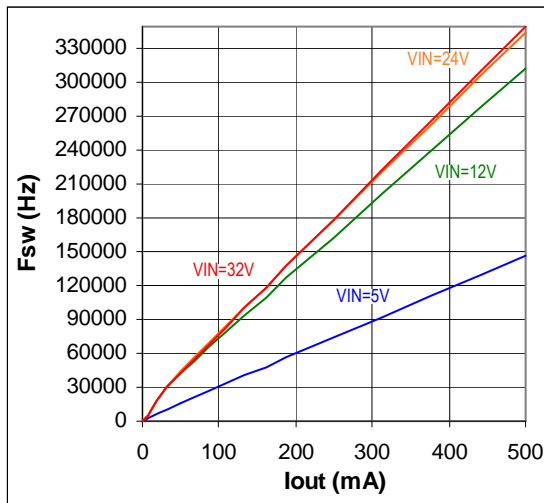

Figure 10. Shutdown Current vs. Temperature

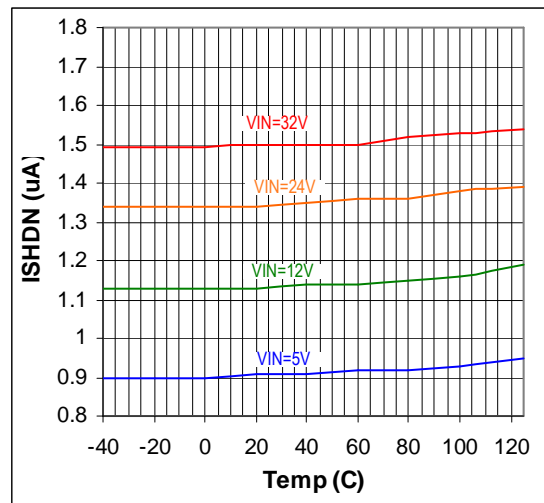

Figure 11. Line Regulation @ $I_{OUT}=10mA$

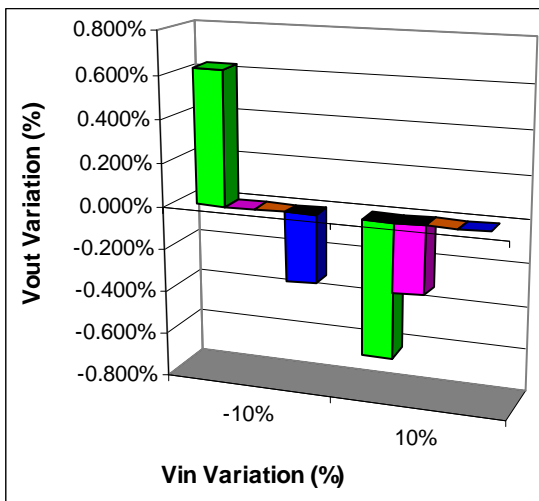

Figure 12. Line Regulation @ $I_{OUT}=500mA$

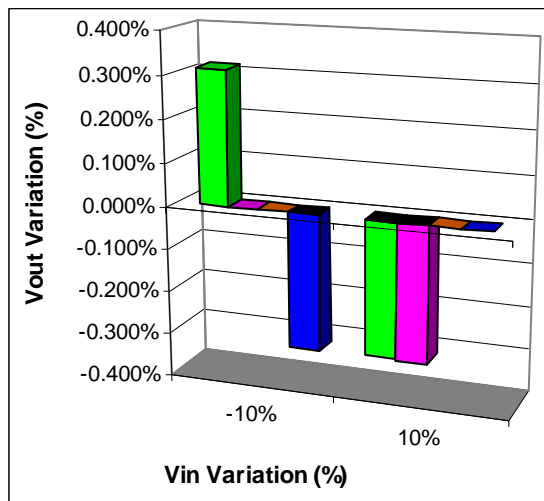



Figure 13. Load Regulation

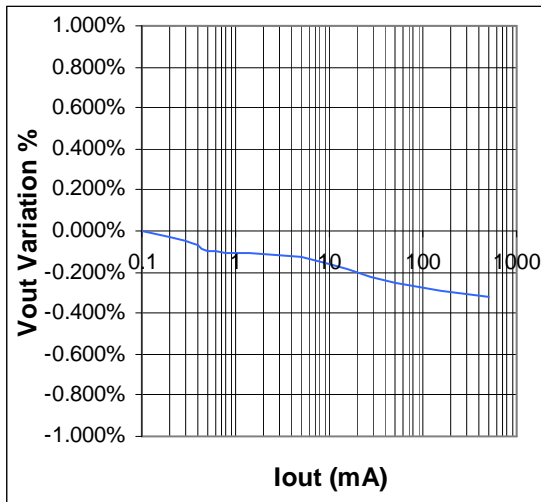

Figure 14. Line Regulation V_{OUT}=5V @ 10mA

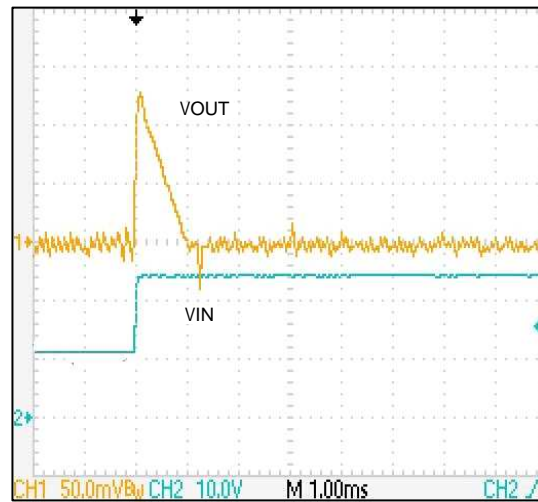

Figure 15. Line Regulation V_{OUT}=5V @ 10mA

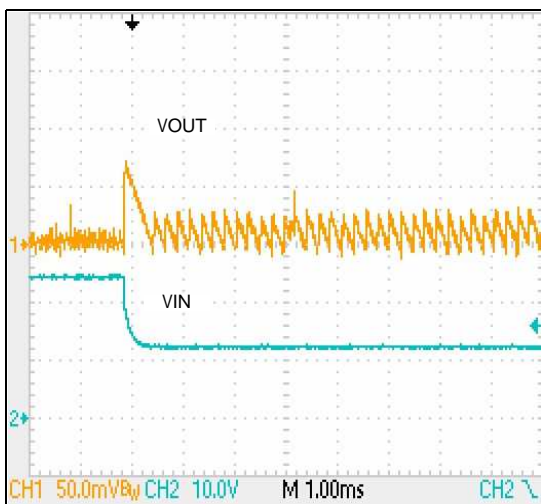
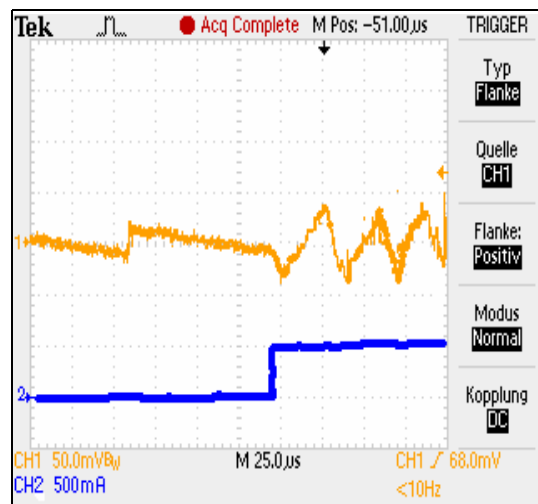

Figure 16. Load Regulation V_{OUT}=5V 10mA→500mA



Note: All measurements taken at V_{IN}=24V, V_{OUT}=3.3V, and T_{AMB}=25°C using the typical application circuit specified in Figure 17, unless otherwise specified.



8 Detailed Description

Figure 17. System Diagram of AS7620-A with Early Power Fail Warning

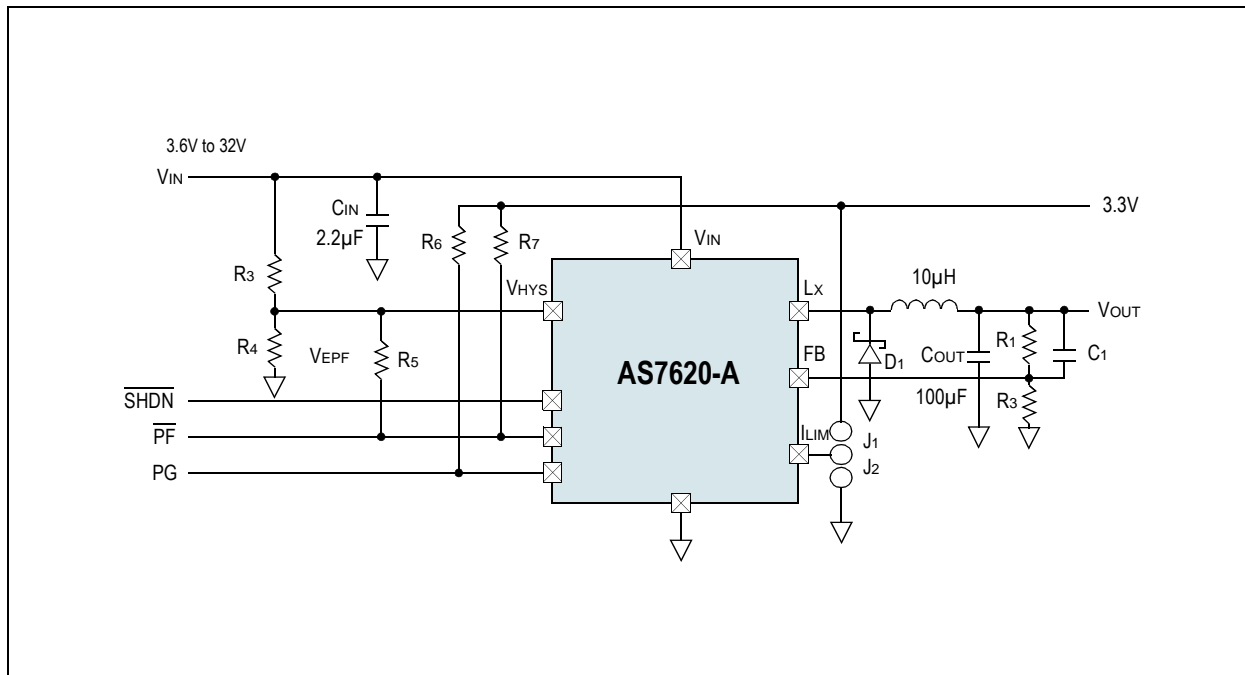

Table 4. AS7620 Output Voltage Options

AS7620	AS7620A-BQFT	AS7620B-BQFT
VOUT	ADJ.	3.3V

8.1 Shut Down

The device can be shut down by providing a voltage lower than 1V at the $\overline{\text{SHDN}}$ pin (7). In this condition, the consumption is only 1µA (typ). The AS7620 is providing an internally regulated pull-up circuit. No external pull-up resistor shall be used, which could otherwise damage the shutdown input. Connect the $\overline{\text{SHDN}}$ input directly to an open drain port only.

8.2 Soft Start

The device implements a soft start by limiting the inrush current into the output choke. Initially, the internal PMOS is turned on until the current reaches the programmed current limit (see [Current Limit on page 9](#)) and then is immediately turned off. It will be turned on again when the current approaches 0A. In this time frame, the FB voltage (VFB) will be lower than the reference and so the duty cycle will be driven by the current limit only.

8.3 Regulation

Both AS7620-A and AS7620-B are based on a hysteretic control method. Moreover, the switch current is monitored to make the converter always work in discontinuous current mode (DCM). The advantages of this type of control system can be summarized as following:

- High efficiency even at light load
- Intrinsically stable
- Simplicity
- Readiness during the load transient

The internal PMOS is switched on when the VFB is lower than $V_{\text{REF}} - V_{\text{HYS}}/2$ and the current is 0A (DCM). The on time will be terminated if the VFB is over $V_{\text{REF}} + V_{\text{HYS}}/2$ or if the current limit (CL) is triggered. In practice, considering the most common application conditions ($L=10\mu\text{H} + 100\mu\text{H}$; $C=10\mu\text{F} - 100\mu\text{F}$) and setting the CL threshold according to the load, the on time is normally terminated by the CL intervention and the output voltage ripple will stay within 1.25% of the output voltage (typ) or $V_{\text{HYS}} * V_{\text{OUT}} / V_{\text{REF}}$.



8.4 V_{OUT} Selection

The AS7620-B features a 3.3V fixed output voltage. The AS7620-A provides an adjustable output from 1.2V (V_{REF}) up to virtually V_{IN} (see [100% Duty Cycle Operation on page 11](#)). To select the desired V_{OUT}, the related resistor divider has to be tuned according to the following formula:

$$V_{OUT} = V_{REF} \cdot \left(1 + \frac{R_h}{R_l}\right) \quad (EQ 1)$$

Where:

R_h is the high side resistor of the output divider

R_l is the resistor of the output divider

Note: It is suggested to select resistors in the range of hundreds of kΩ in order to limit the current consumption.

8.5 Current Limit

The current is sensed during the on time of the internal PMOS. Three different current limit thresholds can be selected by the ILIM pin:

1. 240mA (typ) ILIM shorted to GND
2. 720mA (typ) ILIM shorted to V_{OUT} (from 1.5V to 3.6V)
3. 1000mA (typ) ILIM floating

This threshold is intended as peak current limit. If the current reaches the threshold during the on time, the PMOS is turned off and it will be turned on again only when the current approaches 0A and the feedback voltage is equal or lower than V_{REF}. The maximum output current is ILIM/2.

8.6 Switching Frequency

The switching frequency (f_{sw}) changes according to the application conditions and, in particular, to the output current in order to optimize the efficiency in any load condition. Anyway, it is always possible to estimate the f_{sw} during the design process. As described in the Regulation (refer to page 8) – the converter always works in DCM and, normally, the peak current into the inductor is the CL threshold (ILIM). The average of the inductor current must be equal to the output current. The following formula provides the relationship between inductor current and output current:

$$I_{OUT} = \frac{1}{T_{SW}} \cdot \frac{1}{2} \cdot \frac{ILIM^2 \cdot L \cdot V_{IN}}{(V_{IN} - V_{OUT}) \cdot V_{OUT}} \quad (EQ 2)$$

Consequently, the f_{sw} can be expressed as following:

$$F_{SW} = \frac{2 \cdot I_{OUT} \cdot (V_{IN} - V_{OUT}) \cdot V_{OUT}}{ILIM^2 \cdot L \cdot V_{IN}} \quad (EQ 3)$$

Figure 18. Chart Illustrating the F_{sw} vs. I_{OUT} in a Standard Application (V_{IN}=24V, V_{OUT}=3.3V, L=10μH, ILIM=1A)

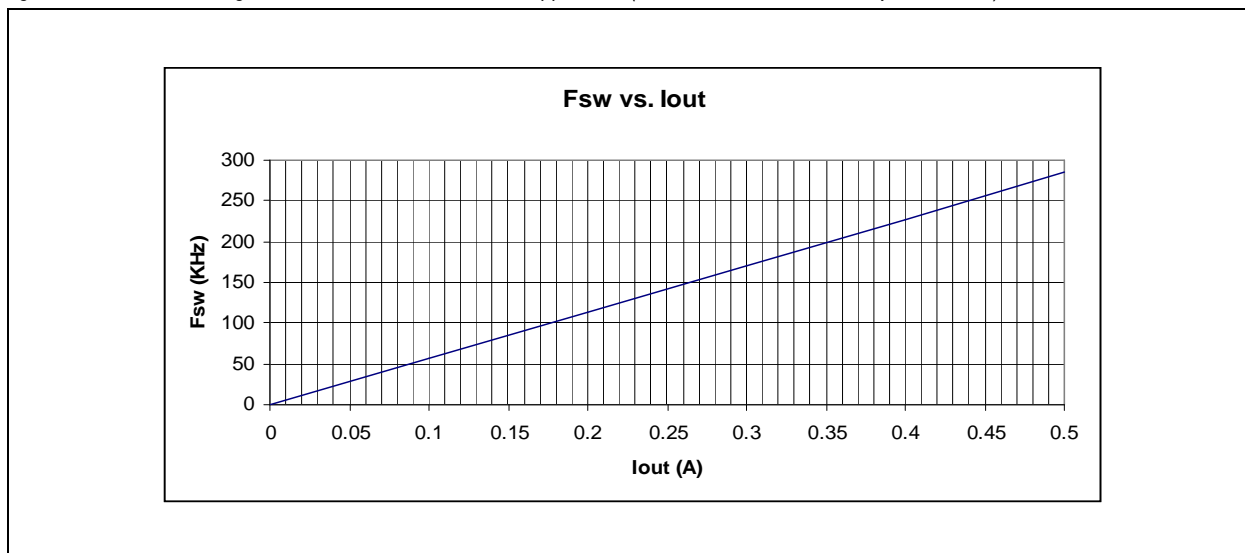



8.7 Power Fail / Power Good

AS7620A-B monitors input and output voltage by VEPF (pin 11) and VFB (pin 5) respectively. Two dedicated flags $\overline{\text{PF}}$ (pin 10) and PG (pin 12) are provided outside to inform about early input power fail (active low) and output within regulation. Figure 19 illustrates the typical connection for VEPF. During start up, PF is initially low. By selecting R3, R4, R5 and R6, it is possible to set the desired input voltage threshold above which the input power is considered stable. Once V_{IN} (VDDH in Figure 19) reaches V_{inTh} , $\overline{\text{PF}}$ is released and so an additional voltage contribution from VDD is added at the VPF pin, realizing in fact a hysteresis to eliminate $\overline{\text{PF}}$ oscillation due to power supply noise.

Figure 19. Open-Drain Output Stage for Comparator

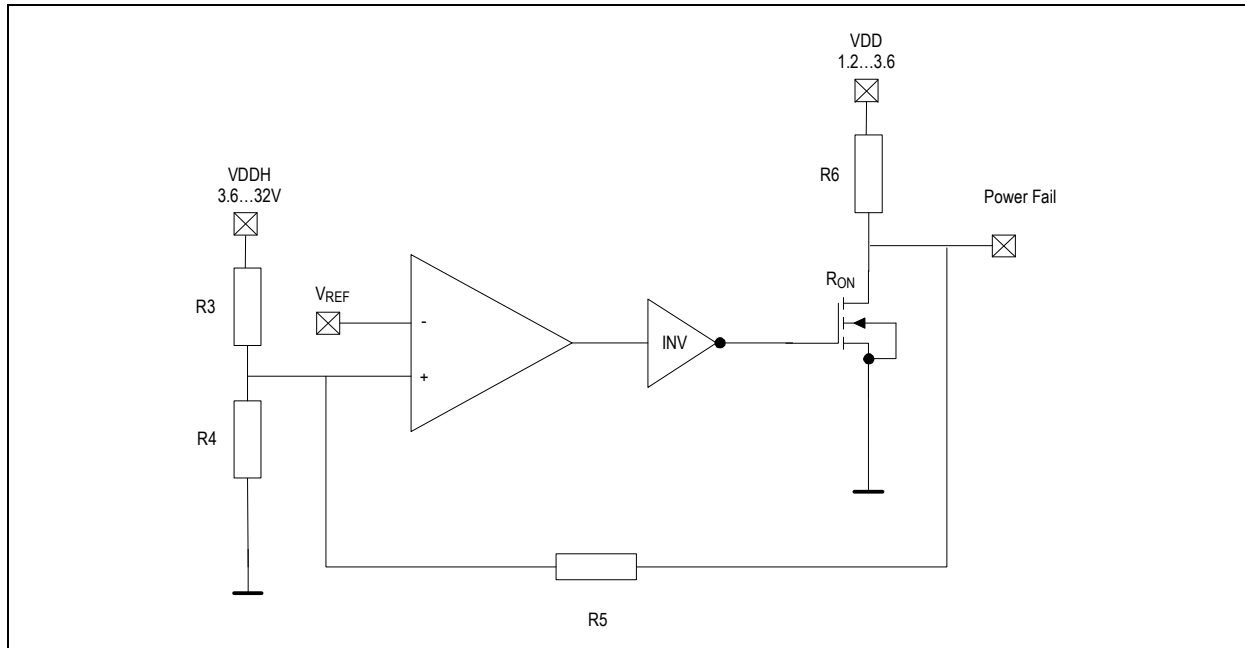

Table 5 provides the resistors values covering all the standard input BUS. The resistors values are 1% commercial values. It is mandatory to use the correct resistors values to guarantee the respect of maximum absolute voltages at EPF and PF pin. VDD has been considered 3.3V. Otherwise EPF pin should be shorted to GND and PF left floating.

Terminology:

VRST: Reset voltage for the EPF. It is 90% of the Input BUS voltage.

VTRIP: Trip voltage for the EPF. It is 80% of the Input BUS voltage.

Table 5. EPF Network Selection with Different Input BUS

V_{IN} (V)	VRST (V)	VTRIP (V)	R3 (K Ω)	R4 (K Ω)	R5 (K Ω)	R6 (K Ω)
5	4.5	4	365	143	1740	1370
6	5.4	4.8	464	143	1870	1430
9	8.1	7.2	768	140	2050	1580
12	10.8	9.6	1070	140	2100	1650
15	13.5	12	1370	140	2150	1690
20	18	16	1870	140	2210	1740
24	21.6	19.2	2260	140	2260	1740
28	25.3	22.5	2670	140	2260	1740

8.8 Thermal Protection

The internal junction temperature is continuously monitored. If it reaches 150°C (min), the PMOS is turned off. The device can switch again if the temperature is decreased by at least 10°C. If the over-temperature persists, the device will be shut down again resulting in a hiccup mode for the output power.



9 Application Information

9.1 Input Capacitors

An input capacitor is required to sustain the peak current requested by the turning on of the internal PMOS. When used, the capacitor helps to reduce the noise and saves the input battery life. The input capacitor has to withstand the input RMS current, which can be calculated by the following formula:

$$I_{rms} = I_{OUT} \cdot \sqrt{\frac{V_{OUT} \cdot (V_{IN} - V_{OUT})}{V_{IN}}} \quad (EQ 4)$$

While designing for wide input/output voltage range, the worst case of $I_{rms} = 1/2 \cdot I_{OUT}$ must be considered. Suggested capacitors are low ESR OSCON, polymer, aluminum or MLCCs. Tantalum types are not recommended for their weakness in withstanding big inrush currents.

9.2 Output Inductor

The inductor together with the output capacitor represents the output filter. Using the AS7620, the inductor is charged and completely discharged at every switching cycle being that the converter is forced to work in DCM. Values from 10µH to 100µH are suitable to work with AS7620 and its selection should consider the following statements:

- Bigger inductor implies lower f_{sw}
- Bigger inductor implies lower bandwidth

The inductor must be rated to withstand the peak current (ILIM) and the RMS current $I_{rms} = \sqrt{I_{OUT}^2 + \frac{\Delta I L^2}{3}}$

9.3 Output Capacitor

The output capacitor together with the inductor represents the output filter. The bigger the capacitance is, the lower will be the output ripple. Usually, low ESR MLCCs are preferred as they are inexpensive and small in size. Any value from 10µF is suitable, considering the load transient specifications of the application as well.

9.4 Free Wheeling Diode

The inductor current is forced through the diode during the off-times. The average current flowing through it is $\frac{1}{2} \cdot f_{sw} \cdot \frac{I_{LIM}^2 \cdot L}{V_{OUT}}$

The reverse voltage must be higher than the input voltage and safely it is common to consider 30% more. Normally, a schottky diode is preferred because of its low forward voltage.

9.5 Stability

Even though the hysteretic voltage mode is intrinsically stable, an excessive noise at the FB could cause instability. For this reason care must be taken drawing the layout, reducing the noise and shielding the FB path from it. The main noise generator is the switching node, which is commutated from GND to VIN by the internal PMOS and the free wheeling diode and through which a pulse current flows. It is wise to add a MLCC capacitor as close as possible to the VIN pin of the device and provide a wide/short path between the LX pin and the external components (inductor and diode). It is preferable to draw the FB path as far as possible from the LX node and, perhaps, shielding it with a GND track. Another recommendation is to use low ESL output capacitors, thus avoiding electrolytic parts. A big ESL adds a square wave contribution on the FB that can make the device work improperly.

9.6 100% Duty Cycle Operation

Thanks to the PMOS structure of the internal switch, the device can actually work at 100% duty cycle. This feature is very helpful during the load transient, because the maximum power can be transferred to the output in order to recover as fastest. The device will try to work at 100% duty whenever the FB voltage is lower than the upper window's threshold. Moreover, in this condition, the safety is always guaranteed by the current limit.



9.7 Demo Board

A demonstration board is available to test the device functionalities and performance in a standard application. For further information, please refer to the AS7620EB datasheet.

Figure 20. Demo Board Photograph





10 Package Drawings and Markings

Figure 21. 12-pin MLPQ 4x4mm Marking

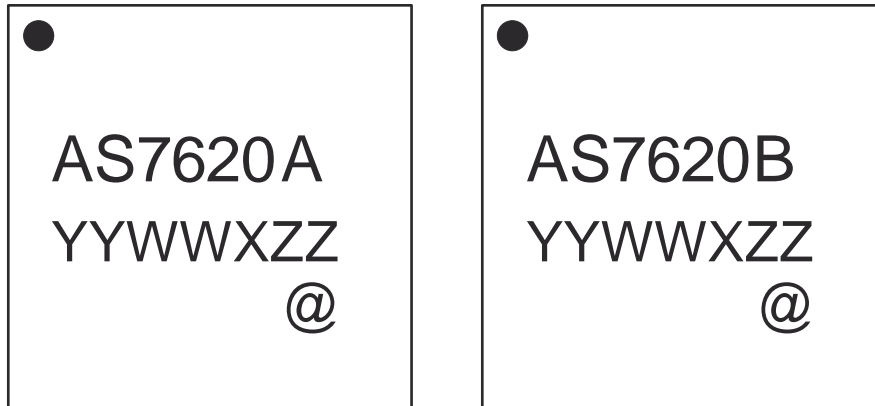
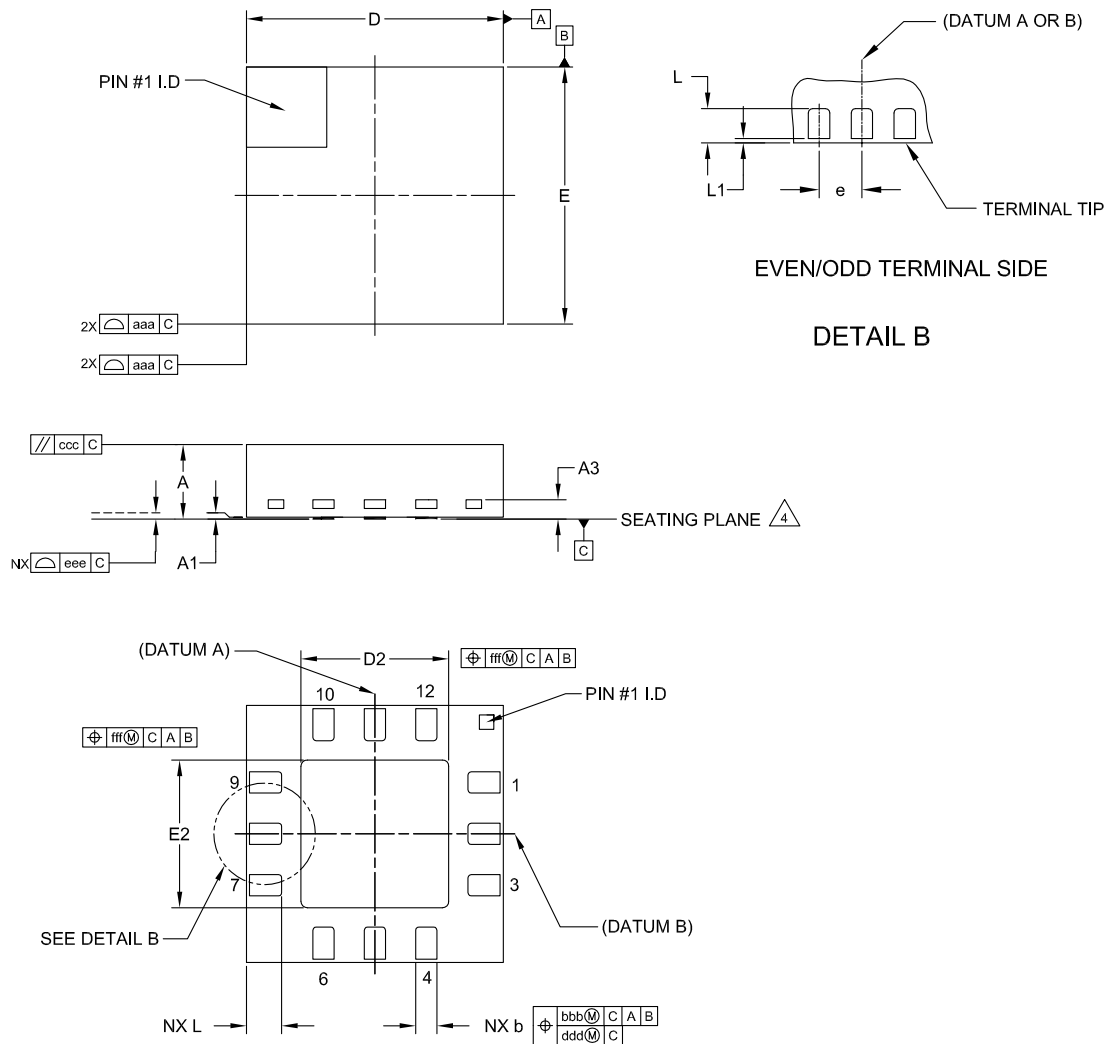

Table 6. Packaging Code

YY	WW	X	ZZ	@
last two digits of the current year	manufacturing week	plant identifier	free choice / traceability code	sublot identifier



Figure 22. 12-pin MLPQ 4x4mm Package



REF.	MIN	NOM	MAX
A	0.80	0.90	1.00
A1	0	0.02	0.05
A3	-	0.20 REF	-
L	0.45	0.55	0.65
L1	0.00	-	0.15
b	0.25	0.30	0.35
D	4.00 BSC		
E	4.00 BSC		
e	0.80 BSC		
D2	2.20	2.30	2.40
E2	2.20	2.30	2.40
aaa	-	0.15	-
bbb	-	0.10	-
ccc	-	0.10	-
ddd	-	0.05	-
eee	-	0.08	-
fff	-	0.10	-
N	12		

NOTE:

1. DIMENSIONING AND TOLERANCING CONFORM TO ASME Y14.5M-1994.
2. ALL DIMENSIONS ARE IN MILLIMETERS. ANGLES ARE IN DEGREES.
3. DIMENSION b APPLIES TO METALLIZED TERMINAL AND IS MEASURED BETWEEN 0.25mm AND 0.30mm FROM TERMINAL TIP. DIMENSION L1 REPRESENTS TERMINAL FULL BACK FROM PACKAGE EDGE UP TO 0.15mm IS ACCEPTABLE.
4. COPLANARITY APPLIES TO THE EXPOSED HEAT SLUG AS WELL AS THE TERMINAL.
5. RADIUS ON TERMINAL IS OPTIONAL.
6. N IS THE TOTAL NUMBER OF TERMINALS.





11 Ordering Information

The devices are available as the standard products shown in [Table 7](#).

Table 7. Ordering Information

Ordering Code	Marking	Output	Description	Delivery Form	Package
AS7620-BQFT	AS7620A	adjustable	500mA Hysteretic High Voltage Step-Down Converter with Dual Power Monitor	Tape and Reel	12-pin MLPQ 4x4mm
AS7620B-BQFT*	AS7620B	3.3V	500mA Hysteretic High Voltage Step-Down Converter with Dual Power Monitor without Output Delay	Tape and Reel	12-pin MLPQ 4x4mm

*Available on request

Note: All products are RoHS compliant.
Buy our products or get free samples online at ICdirect: <http://www.ams.com/ICdirect>

Technical Support is found at <http://www.ams.com/Technical-Support>

For further information and requests, please contact us <mailto:sales@ams.com>
or find your local distributor at <http://www.ams.com/distributor>



Copyrights

Copyright © 1997-2011, ams AG, Tobelbaderstrasse 30, 8141 Unterpemstaetten, Austria-Europe. Trademarks Registered ®. All rights reserved. The material herein may not be reproduced, adapted, merged, translated, stored, or used without the prior written consent of the copyright owner.

All products and companies mentioned are trademarks or registered trademarks of their respective companies.

Disclaimer

Devices sold by ams AG are covered by the warranty and patent indemnification provisions appearing in its Term of Sale. ams AG makes no warranty, express, statutory, implied, or by description regarding the information set forth herein or regarding the freedom of the described devices from patent infringement. ams AG reserves the right to change specifications and prices at any time and without notice. Therefore, prior to designing this product into a system, it is necessary to check with ams AG for current information. This product is intended for use in normal commercial applications. Applications requiring extended temperature range, unusual environmental requirements, or high reliability applications, such as military, medical life-support or life-sustaining equipment are specifically not recommended without additional processing by ams AG for each application. For shipments of less than 100 parts the manufacturing flow might show deviations from the standard production flow, such as test flow or test location.

The information furnished here by ams AG is believed to be correct and accurate. However, ams AG shall not be liable to recipient or any third party for any damages, including but not limited to personal injury, property damage, loss of profits, loss of use, interruption of business or indirect, special, incidental or consequential damages, of any kind, in connection with or arising out of the furnishing, performance or use of the technical data herein. No obligation or liability to recipient or any third party shall arise or flow out of ams AG rendering of technical or other services.



Contact Information

Headquarters

ams AG
Tobelbaderstrasse 30
A-8141 Unterpemstaetten, Austria

Tel: +43 (0) 3136 500 0
Fax: +43 (0) 3136 525 01

For Sales Offices, Distributors and Representatives, please visit:

<http://www.ams.com/contact>



Компания «ЭлектроПласт» предлагает заключение долгосрочных отношений при поставках импортных электронных компонентов на взаимовыгодных условиях!

Наши преимущества:

- Оперативные поставки широкого спектра электронных компонентов отечественного и импортного производства напрямую от производителей и с крупнейших мировых складов;
- Поставка более 17-ти миллионов наименований электронных компонентов;
- Поставка сложных, дефицитных, либо снятых с производства позиций;
- Оперативные сроки поставки под заказ (от 5 рабочих дней);
- Экспресс доставка в любую точку России;
- Техническая поддержка проекта, помощь в подборе аналогов, поставка прототипов;
- Система менеджмента качества сертифицирована по Международному стандарту ISO 9001;
- Лицензия ФСБ на осуществление работ с использованием сведений, составляющих государственную тайну;
- Поставка специализированных компонентов (Xilinx, Altera, Analog Devices, Intersil, Interpoint, Microsemi, Aeroflex, Peregrine, Syfer, Eurofarad, Texas Instrument, Miteq, Cobham, E2V, MA-COM, Hittite, Mini-Circuits, General Dynamics и др.);

Помимо этого, одним из направлений компании «ЭлектроПласт» является направление «Источники питания». Мы предлагаем Вам помощь Конструкторского отдела:

- Подбор оптимального решения, техническое обоснование при выборе компонента;
- Подбор аналогов;
- Консультации по применению компонента;
- Поставка образцов и прототипов;
- Техническая поддержка проекта;
- Защита от снятия компонента с производства.



Как с нами связаться

Телефон: 8 (812) 309 58 32 (многоканальный)

Факс: 8 (812) 320-02-42

Электронная почта: org@eplast1.ru

Адрес: 198099, г. Санкт-Петербург, ул. Калинина, дом 2, корпус 4, литера А.