

This document is the property of Amphenol Corporation and is delivered on the express condition that it is not to be disclosed, reproduced or used, in whole or in part, for manufacture or sale by anyone other than Amphenol Corporation without the prior consent. It is not to be used to disclose or to use any information in this document.

REVISIONS				
SYM	ECN	DESCRIPTION	DATE	APPROVED
		SEE SHEET 1		

ORDERING INFORMATION

E 842 - 816 - XX XX - X XX X

Date code _____
 Nil - No date code
 E - Date code printed Δ

No. of contact _____

Body & pin configuration _____
 (Refer to Table III)

Lock & Eject (L&E) and mounting stud options _____
 0 - no L&E, no stud
 1 - short L&E, no stud
 2 - short L&E, short stud
 3 - short L&E, long stud
 4 - long L&E, no stud
 5 - long L&E, short stud
 6 - long L&E, long stud
 F - long L&E, M2.5 stud

Nil - standard
 S - standard with polarizing key slot for size 10 Δ

Plating
 AA - gold flash duplex
 19 - 15u" gold plated duplex
 35 - 30u" gold plated duplex

Notes:

- Connectors purchased under this drawing will mate with MIL-C-83503/7B socket connector with strain relief or without strain relief and Amphenol's 812 connector.
- This assembly is designed to meet requirements of MIL-C-83503.
- Δ The polarizing key slot on this end does not exist on size 10 and 14.
- Δ Prefix "E" only applies to the four-sided version & polarizing key slot is available for all size including size 10.
- Δ Suffix "S" only applies to the size 10 since the polarizing key slot is absent from the standard size 10.
- This connector is both UL and CSA approved.
- Refer to Amphenol S-816-001 for product specification.
- MATERIAL SHOULD BE FULFILLED AMPHENOL SPEC#SSN001.

Table III

Standard product - four side grey	Non-standard product - three side grey (specific quantity required)	K
30 - straight solder tail, for 0.062" [1.6 mm] PCB	20 - obsolete	0.109 ± 0.007 ± 0.022 [2.61 ± 0.34] coined tail
31 - straight solder tail, for 0.125" [3.2 mm] PCB	21 - obsolete	0.171 ± 0.008 ± 0.022 [4.14 ± 0.36] coined tail
32 - right angle solder tail, for 0.062" [1.6 mm] PCB	22 - obsolete	0.109 ± 0.007 ± 0.022 [2.61 ± 0.34] coined tail
33 - right angle solder tail, for 0.125" [3.2 mm] PCB	23 - obsolete	0.171 ± 0.008 ± 0.022 [4.14 ± 0.36] coined tail
37 - straight wire wrap tail	27 - obsolete	0.61 ± 0.015 [15.49 ± 0.38] square tail
39 - right angle wire wrap tail	29 - obsolete	0.61 ± 0.015 [15.49 ± 0.38] square tail

Table IV

Size	A	B	C	D	E	F
10	1.26 [32.07]	1.10 [27.94]	0.860 [21.84]	0.708 [17.98]	0.400 [10.16]	4
14	1.46 [37.08]	1.30 [33.02]	1.060 [26.92]	0.908 [23.06]	0.600 [15.24]	6
16	1.56 [39.62]	1.40 [35.56]	1.160 [29.46]	1.008 [25.60]	0.700 [17.78]	7
20	1.76 [44.70]	1.60 [40.64]	1.360 [34.54]	1.208 [30.68]	0.900 [22.86]	9
26	2.06 [52.32]	1.90 [48.26]	1.660 [42.16]	1.508 [38.30]	1.200 [30.40]	12
30	2.26 [57.40]	2.10 [53.34]	1.860 [47.24]	1.708 [43.38]	1.400 [35.56]	14
34	2.46 [62.48]	2.30 [58.42]	2.060 [52.32]	1.908 [48.46]	1.600 [40.64]	16
40	2.76 [70.10]	2.60 [66.04]	2.360 [59.94]	2.208 [56.08]	1.900 [48.26]	19
50	3.26 [82.80]	3.10 [78.74]	2.860 [72.64]	2.708 [68.78]	2.400 [60.96]	24
60	3.76 [95.50]	3.60 [91.44]	3.360 [85.34]	3.208 [81.48]	2.900 [73.66]	29
64	3.96 [100.58]	3.80 [96.52]	3.560 [90.42]	3.408 [86.60]	3.100 [78.74]	31

Recommended PCB layout

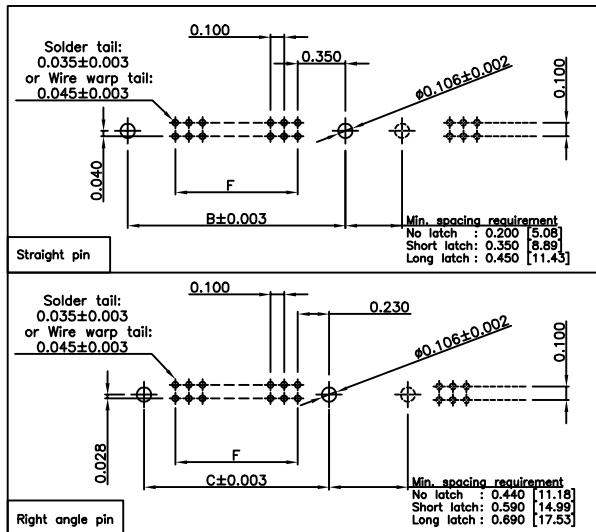

Customer Drawing

UNLESS OTHERWISE SPECIFIED TOLERANCES		APPROVAL	DATE	Amphenol	
U.S.	METRIC	DRAWN ALEXLEE	07/18/05		
.X	+/- .020	0.51		TITLE 816 Protected Header	
.XX	+/- .010	0.25			
.XXX	+/- .005	0.13			
FOR MATERIALS AND FINISHES SEE NOTES		CHECKED TSUI	07/18/05	DRAWING FILE : DRAWING_816_CB16.DWG	
REMOVE SHARP EDGES		ANGLE OF PROJECTION			
DIMENSIONS				SIZE A3	
U.S.	INCHES	DRAWING NO. C816-XXXX-XXX			
METRIC	MM	SCALE NONE		REV. T	
				SHEET 2 OF 2	

This document is the property of Amphenol Corporation and is delivered on the express condition that it is not to be disclosed, reproduced or used, in whole or in part, for manufacture or sale by anyone other than Amphenol Corporation without the prior consent, & that no right is granted to disclose or to use any information in this document.

REVISIONS				
SYM	ECN	DESCRIPTION	DATE	APPROVED
Q	HK1421	RELEASE TO CUSTOMER	06/12/97	NELSON
R	HK1513	***TAIL SIZE MODIFIED	06/01/98	Michael Tsai
S	HK2043	Revise L&E options&delete three side option	8/24/01	Michael IP
T	HK3437	UPDATE DRAWING TO COMPLY WITH RoHS	07/18/05	Michael IP

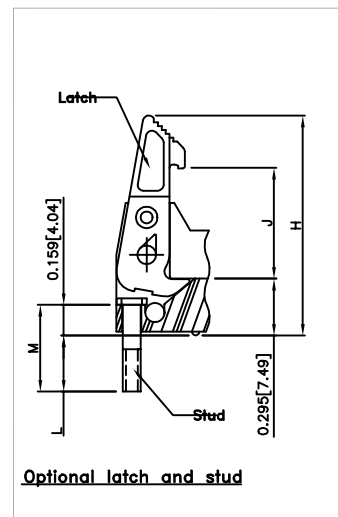
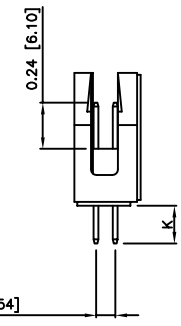
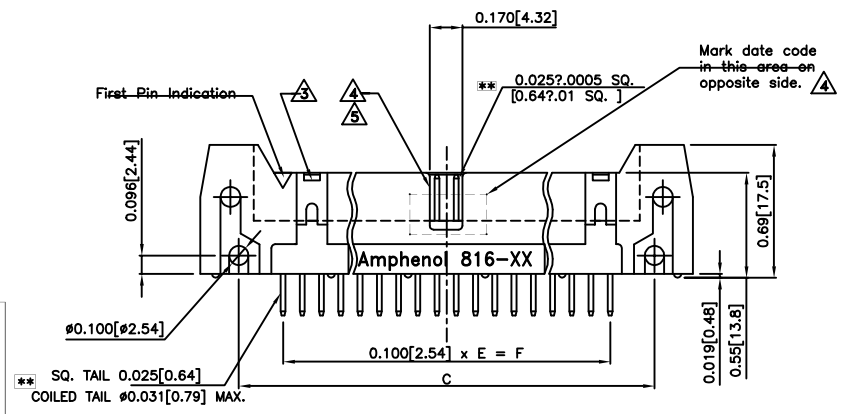
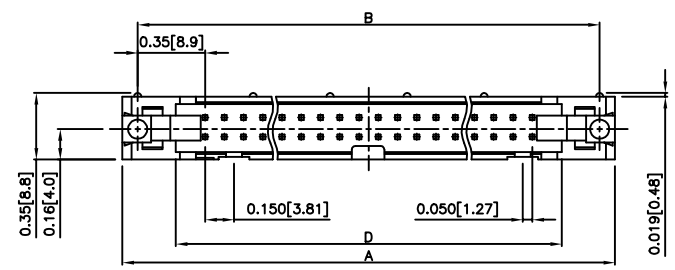

	Size 14 P/N: X842-816-14XX-XXX		Size 34 or above P/N: X842-816-XXXX-XXX
	Size 10 with CPK slot P/N: 842-816-10XX-XXXS, or P/N: E842-816-10XX-XXX with date code		Size 20 P/N: X842-816-20XX-XXX
	Size 10 without CPK slot P/N: 842-816-10XX-XXX		Size 16 P/N: X842-816-16XX-XXX

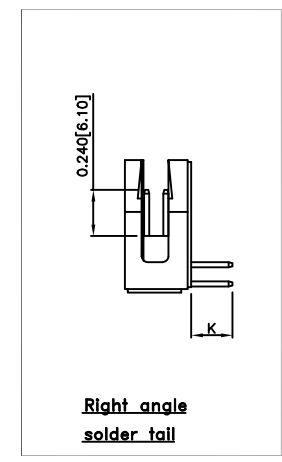

Customer Drawing

Table I

Latch & Eject	J	H
Short: for use with non strain relief socket	0.425 [10.80]	1.015 [25.78]
Long for use with strain relief socket	0.575 [14.61]	1.135 [28.83]

Table II

Stud	L	M
Short stud 2-56	0.29 [7.4]	0.45 [11.43]
Long stud 2-56	0.36 [9.1]	0.52 [13.21]
Stud M2.5	0.18 [4.6]	0.34 [8.6]

Note: unit in inch [mm]

UNLESS OTHERWISE SPECIFIED TOLERANCES U.S. METRIC .X +/- .020 0.51 .XX +/- .010 0.25 .XXX +/- .005 0.13 FRACTIONS +/- ANGLES +/- 2.5° 2.5°	APPROVAL	DATE	Amphenol TITLE 816 Protected Header SIZE DRAWING NO. A3 C816-XXXX-XXX SCALE NONE SHEET 1 OF 2
	DRAWN ALEX.LEE	07/18/05	
	CHECKED TSUN	07/18/05	
	CHECKED		
FOR MATERIALS AND FINISHES SEE NOTES	DRAWING FILE: \DRAWING_816\C816.DWG	ANGLE OF PROJECTION	REV. T
REMOVE SHARP EDGES			
DIMENSIONS			
U.S. INCHES			
METRIC MM			



Компания «ЭлектроПласт» предлагает заключение долгосрочных отношений при поставках импортных электронных компонентов на взаимовыгодных условиях!

Наши преимущества:

- Оперативные поставки широкого спектра электронных компонентов отечественного и импортного производства напрямую от производителей и с крупнейших мировых складов;
- Поставка более 17-ти миллионов наименований электронных компонентов;
- Поставка сложных, дефицитных, либо снятых с производства позиций;
- Оперативные сроки поставки под заказ (от 5 рабочих дней);
- Экспресс доставка в любую точку России;
- Техническая поддержка проекта, помощь в подборе аналогов, поставка прототипов;
- Система менеджмента качества сертифицирована по Международному стандарту ISO 9001;
- Лицензия ФСБ на осуществление работ с использованием сведений, составляющих государственную тайну;
- Поставка специализированных компонентов (Xilinx, Altera, Analog Devices, Intersil, Interpoint, Microsemi, Aeroflex, Peregrine, Syfer, Eurofarad, Texas Instrument, Miteq, Cobham, E2V, MA-COM, Hittite, Mini-Circuits, General Dynamics и др.);

Помимо этого, одним из направлений компании «ЭлектроПласт» является направление «Источники питания». Мы предлагаем Вам помощь Конструкторского отдела:

- Подбор оптимального решения, техническое обоснование при выборе компонента;
- Подбор аналогов;
- Консультации по применению компонента;
- Поставка образцов и прототипов;
- Техническая поддержка проекта;
- Защита от снятия компонента с производства.



Как с нами связаться

Телефон: 8 (812) 309 58 32 (многоканальный)

Факс: 8 (812) 320-02-42

Электронная почта: org@eplast1.ru

Адрес: 198099, г. Санкт-Петербург, ул. Калинина, дом 2, корпус 4, литера А.