

ASSY. NO. (CAT. NO.)	LED COLOR	
	POSITION 1	POSITION 2
553-0101F	BLANK	RED
553-0102F	BLANK	GREEN
553-0103F	BLANK	YELLOW
553-0107F	BLANK	ORANGE
553-0108F	BLANK	BLUE
553-0110F	RED	BLANK
553-0111F	RED	RED
553-0112F	RED	GREEN
553-0113F	RED	YELLOW
553-0118F	RED	BLUE
553-0120F	GREEN	BLANK
553-0121F	GREEN	RED
553-0122F	GREEN	GREEN
553-0123F	GREEN	YELLOW
553-0127F	GREEN	ORANGE
553-0128F	GREEN	BLUE
553-0130F	YELLOW	BLANK
553-0131F	YELLOW	RED
553-0132F	YELLOW	GREEN
553-0133F	YELLOW	YELLOW
553-0171F	ORANGE	RED
553-0172F	ORANGE	GREEN
553-0173F	ORANGE	YELLOW
553-0177F	ORANGE	ORANGE
553-0181F	BLUE	RED
553-0182F	BLUE	GREEN
553-0188F	BLUE	BLUE
553-0199F	WHITE	WHITE
553-0201F	BLANK	RED
553-0202F	BLANK	GREEN
553-0203F	BLANK	YELLOW
553-0210F	RED	BLANK
553-0211F	RED	RED
553-0212F	RED	GREEN
553-0213F	RED	YELLOW
553-0220F	GREEN	BLANK
553-0221F	GREEN	RED
553-0222F	GREEN	GREEN
553-0223F	GREEN	YELLOW
553-0230F	YELLOW	BLANK
553-0231F	YELLOW	RED
553-0232F	YELLOW	GREEN
553-0233F	YELLOW	YELLOW
553-0301F	BLANK	RED
553-0302F	BLANK	GREEN
553-0303F	BLANK	YELLOW
553-0310F	RED	BLANK
553-0311F	RED	RED
553-0312F	RED	GREEN
553-0313F	RED	YELLOW
553-0320F	GREEN	BLANK
553-0321F	GREEN	RED
553-0322F	GREEN	GREEN
553-0323F	GREEN	YELLOW
553-0331F	YELLOW	RED
553-0332F	YELLOW	GREEN
553-0333F	YELLOW	YELLOW

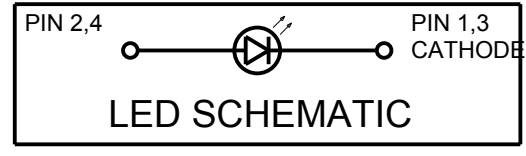

RoHS COMPLIANT 553-0XXXF
 Part Numbers with the "F" suffix ending are RoHS Compliant.
 For example: 553-0101F
 Packaging is marked with "RoHS Compliant" label or equivalent markings. Parts can be wave soldered, dip soldered or hand soldered using typical lead-free soldering process with max 260°C temp. for 5 sec.

BIN	LIMITS (WHITE LED) (CHROMATICITY COORDINATES)			
	X	Y	Z	U
A3	0.270	0.270	0.250	0.250
	0.275	0.325	0.300	0.250
A4	0.270	0.250	0.250	0.270
	0.275	0.250	0.200	0.225
B3	0.290	0.290	0.270	0.270
	0.300	0.350	0.325	0.275
B4	0.290	0.270	0.270	0.290
	0.300	0.275	0.225	0.250
C3	0.310	0.310	0.290	0.290
	0.325	0.375	0.350	0.300
C4	0.310	0.290	0.290	0.310
	0.325	0.300	0.250	0.275
D3	0.330	0.330	0.310	0.310
	0.350	0.400	0.375	0.325
D4	0.330	0.310	0.310	0.330
	0.350	0.325	0.275	0.300

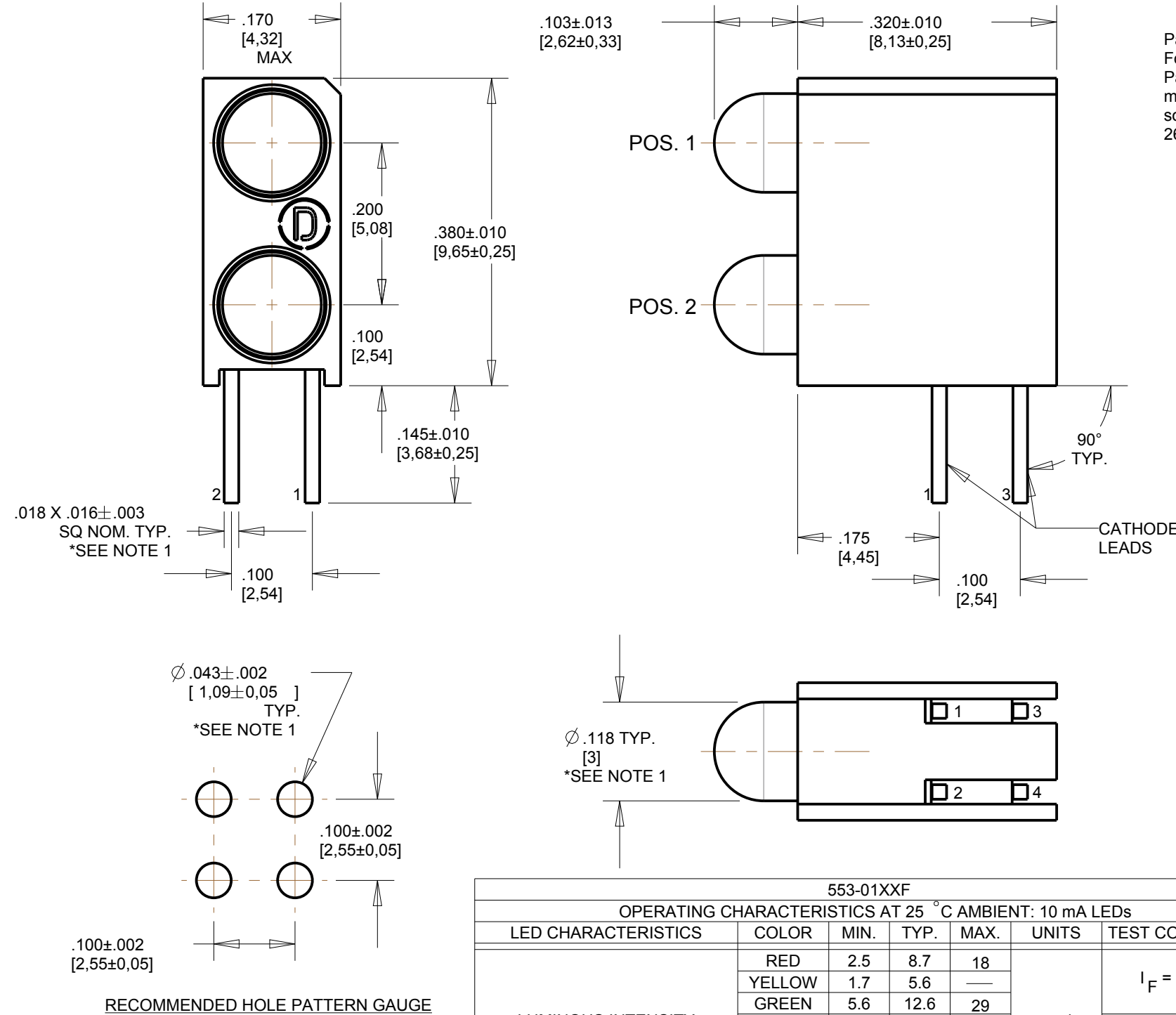
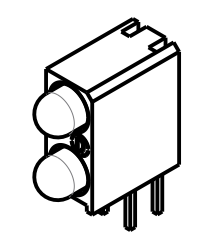

SCALE 2.000



ATTENTION:
 OBSERVE PRECAUTIONS FOR
 HANDLING ELECTROSTATIC
 SENSITIVE DEVICES

NOTES:

- (FOR ORANGE: LEADS .018 SQ. NOM.), LED BODY ϕ .115±.010 AND THE PC BOARD TOLERANCE ON LEAD THICKNESS TO BE ±.003.
- LED LEAD DIMENSIONS SHOWN ARE MEASURED AT HOUSING EXIT.
- LEADS TO FIT INTO HOLES SPACED AS PER PATTERN.
- PIN NUMBERS FOR REFERENCE ONLY, DESIGNATION NON-EXISTENT ON PART.
- DIALIGHT PART NUMBERS: 553-0XXXF.
- THIS ASSEMBLY CONTAINS ELECTROSTATIC DISCHARGE SENSITIVE DEVICES (ESDS). MAINTAIN ALL PRECAUTIONARY MEASURES DURING ASSEMBLY, HANDLING, AND STORAGE IN ACCORDANCE WITH IPC-A-610.

553-01XXF						
OPERATING CHARACTERISTICS AT 25 °C AMBIENT: 10 mA LEDs						
LED CHARACTERISTICS	COLOR	MIN.	TYP.	MAX.	UNITS	TEST CONDITIONS
LUMINOUS INTENSITY	RED	2.5	8.7	18	mcd	$I_F = 10 \text{ mA}$
	YELLOW	1.7	5.6	—		
	GREEN	5.6	12.6	29		
	BLUE	11	16	23		
	ORANGE	3.4	7.0	10.8		
	WHITE	400	1100	1900		
PEAK WAVELENGTH	RED		635		nm	$I_F = 10 \text{ mA}$
	YELLOW		588			
	GREEN		565			
	BLUE		468			
	ORANGE		600			
	WHITE					
DOMINANT WAVELENGTH	RED	615	625	632	nm	$I_F = 10 \text{ mA}$
	YELLOW	585	590	595		
	GREEN	564	568	573		
	BLUE	460	467	475		
	ORANGE	597	602	616		
	WHITE					
FORWARD VOLTAGE	RED		2.0	2.6	V	$I_F = 10 \text{ mA}$
	YELLOW		2.1	2.6		
	GREEN		2.1	2.6		
	BLUE	2.0	2.7	4.1		
	ORANGE	1.5	1.9	3.5		
	WHITE		3.5	4.0		
REVERSE CURRENT	RED			100	μA	$V_R = 5\text{V}$
	YELLOW			100		
	GREEN			100		
	BLUE			10		
	ORANGE			100		
	WHITE			100		
VIEWING ANGLE	RED		60		DEGREE	$I_F = 10 \text{ mA}$
	YELLOW		60			
	GREEN		60			
	BLUE		100			
	ORANGE		60			
	WHITE		45			

553-03XXF						
OPERATING CHARACTERISTICS AT 25 °C AMBIENT: 5 V INTEGRAL RESISTOR LEDs						
LED CHARACTERISTICS	COLOR	MIN.	TYP.	MAX.	UNITS	TEST CONDITIONS
LUMINOUS INTENSITY	RED	8.7	29.0		mcd	$V_F = 5\text{V}$
	YELLOW	3.7	12.6			
	GREEN	5.6	19.0			
PEAK WAVELENGTH	RED		635		nm	$I_F = 10 \text{ mA}$
	YELLOW		585			
	GREEN		565			
FORWARD CURRENT	RED		10	20	mA	$V_F = 5\text{V}$
	YELLOW		10	20		
	GREEN		10	20		
REVERSE CURRENT	RED			100	μA	$V_R = 5\text{V}$
	YELLOW			100		
	GREEN			100		
VIEWING ANGLE	ALL		60		DEGREE	

553-02XXF						
OPERATING CHARACTERISTICS AT 25 °C AMBIENT: 2 mA LOW CURRENT LEDs						
LED CHARACTERISTICS	COLOR	MIN.	TYP.	MAX.	UNITS	TEST CONDITIONS
LUMINOUS INTENSITY	RED	0.75	2.5		mcd	$I_F = 2 \text{ mA}$
	YELLOW	0.4	4.5			
	GREEN	0.4	1.1			
PEAK WAVELENGTH	RED		635		nm	$I_F = 2 \text{ mA}$
	YELLOW		585			
	GREEN		565			
FORWARD VOLTAGE	RED	1.7	2.2		V	$I_F = 2 \text{ mA}$
	YELLOW	1.8	2.2			
	GREEN	1.9	2.2			
REVERSE CURRENT	ALL			10	μA	$V_R = 5\text{V}$
VIEWING ANGLE	ALL		60		DEGREE	

553-03XXF				
ABSOLUTE MAXIMUM RATINGS AT 25 °C AMBIENT				
	COLOR			UNITS
	RED	GREEN	YELLOW	
CONTINUOUS FORWARD VOLTAGE	7.5			V
REVERSE VOLTAGE	5			V
LINEAR DERATING FROM 50 °C	0.071			$\text{mW}/^\circ\text{C}$
LEAD SOLDERING TEMPERATURE (.063" [1.6mm] FROM BODY) FOR 5 SEC.	260			$^\circ\text{C}$
OPERATING TEMPERATURE	-40 TO +85			$^\circ\text{C}$
STORAGE TEMPERATURE	-55 TO +100			$^\circ\text{C}$

553-01XXF							
ABSOLUTE MAXIMUM RATINGS AT 25 °C AMBIENT							
	COLOR						UNITS
	RED	YELLOW	GREEN	BLUE	ORANGE	WHITE	
POWER DISSIPATION	100	60	120	120	135	120	mW
PEAK FORWARD CURRENT (1/5 DUTY CYCLE, 1 ms PULSE WIDTH) (1/10, .1ms FOR BLUE) ($t_c < 10 \mu\text{s}$ D= .005 FOR ORANGE)	90	60	90	100	500	100	mA
CONTINUOUS FORWARD CURRENT	30	20	30	30	30	30	mA
LINEAR DERATING FROM 50 °C (30 °C FOR BLUE, 30 °C FOR WHITE)	0.40	0.25	0.40	.5	0.50	.45	$\text{mA}/^\circ\text{C}$
REVERSE VOLTAGE	5						V
LEAD SOLDERING TEMPERATURE (.063" [1.6mm] FROM BODY) FOR 5 SEC.	260						$^\circ\text{C}$
OPERATING TEMPERATURE	-55 TO +100		-40 TO +85		-55 TO +100		$^\circ\text{C}$
STORAGE TEMPERATURE	-55 TO +100		-55 TO +100		-40 TO +100		$^\circ\text{C}$

THIS DRAWING AND THE CONTENTS HEREIN ARE CONFIDENTIAL AND THE SOLE PROPERTY OF DIALIGHT CORP. REPRODUCTION OF THIS DRAWING OR CONSTRUCTION OF ANY PARTS WITHIN THIS DRAWING ARE FORBIDDEN WITHOUT THE WRITTEN CONSENT OF DIALIGHT CORP.

SCALE: 6.000

DRAWING NUMBER: **C-17277**

REV: **K**

TOLERANCES: UNLESS OTHERWISE SPECIFIED

FRACTIONS: $\pm 1/64$

DECIMALS (XX): $\pm .02$

DECIMALS (XXX): $\pm .015$

ANGLES: $\pm 3^\circ$

FINISH

TITLE: **3mm LED BI-LEVEL CBI**
RoHS COMPLIANT

MATERIAL

Dialight 1501 ROUTE 34 SOUTH FARMINGDALE, NJ 07727 (732) 919-3119 www.dialight.com

FSCM 83330

SHEET 1 OF 1 FAMILY TABLES:



Компания «ЭлектроПласт» предлагает заключение долгосрочных отношений при поставках импортных электронных компонентов на взаимовыгодных условиях!

Наши преимущества:

- Оперативные поставки широкого спектра электронных компонентов отечественного и импортного производства напрямую от производителей и с крупнейших мировых складов;
- Поставка более 17-ти миллионов наименований электронных компонентов;
- Поставка сложных, дефицитных, либо снятых с производства позиций;
- Оперативные сроки поставки под заказ (от 5 рабочих дней);
- Экспресс доставка в любую точку России;
- Техническая поддержка проекта, помощь в подборе аналогов, поставка прототипов;
- Система менеджмента качества сертифицирована по Международному стандарту ISO 9001;
- Лицензия ФСБ на осуществление работ с использованием сведений, составляющих государственную тайну;
- Поставка специализированных компонентов (Xilinx, Altera, Analog Devices, Intersil, Interpoint, Microsemi, Aeroflex, Peregrine, Syfer, Eurofarad, Texas Instrument, Miteq, Cobham, E2V, MA-COM, Hittite, Mini-Circuits, General Dynamics и др.);

Помимо этого, одним из направлений компании «ЭлектроПласт» является направление «Источники питания». Мы предлагаем Вам помощь Конструкторского отдела:

- Подбор оптимального решения, техническое обоснование при выборе компонента;
- Подбор аналогов;
- Консультации по применению компонента;
- Поставка образцов и прототипов;
- Техническая поддержка проекта;
- Защита от снятия компонента с производства.



Как с нами связаться

Телефон: 8 (812) 309 58 32 (многоканальный)

Факс: 8 (812) 320-02-42

Электронная почта: org@eplast1.ru

Адрес: 198099, г. Санкт-Петербург, ул. Калинина, дом 2, корпус 4, литера А.