

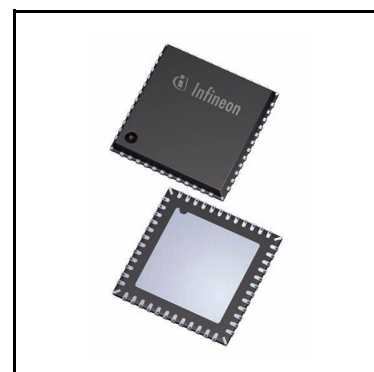
# TLE9263BQXV33

## System Basis Chip

### Mid-Range+ System Basis Chip Family



### Quality Requirement Category: Automotive



### Features

- Two integrated Low-Drop Voltage Regulators: Main regulator (5 V or 3.3 V up to 250 mA) and auxiliary regulator (5 V up to 100 mA) with off-board usage protection
- Voltage regulator (5 V, 3.3 V or 1.8 V) with external PNP transistor configurable for off-board usage or for load sharing
- 1 high-speed CAN transceiver supporting FD communication up to 5 Mbit/s featuring CAN Partial Networking & CAN FD tolerant mode according to ISO 11898-2:2016 & SAE J2284
- 2 LIN transceivers LIN2.2A/J2602
- 4 high-side outputs 7  $\Omega$  typ., 2 HV GPIOs, 3 HV wake inputs
- Integrated fail-safe and supervision functions, e.g. fail-safe, watchdog, interrupt- and reset outputs
- 16-bit SPI for configuration and diagnostics

### Applications

- Body Control Modules (BMC), Passive keyless entry and start modules, Gateway applications
- Heating, ventilation and air conditioning (HVAC)
- Seat, roof, tailgate, trailer, door and other closure modules
- Light control modules
- Gear shifters and selectors

### Description

Body System IC with Integrated Voltage Regulators, Power Management Functions, HS-CAN Transceiver supporting CAN FD and Multiple LIN Transceiver.  
Featuring Multiple High-Side Switches and High-Voltage Wake Inputs.

Type	Package	Marking
TLE9263BQXV33	PG-VQFN-48-31	TLE9263BQXV33

## Table of Contents

<b>1</b>	<b>Overview</b> .....	<b>6</b>
<b>2</b>	<b>Block Diagram</b> .....	<b>8</b>
<b>3</b>	<b>Pin Configuration</b> .....	<b>9</b>
3.1	Pin Assignment .....	9
3.2	Pin Definitions and Functions .....	10
3.3	Hints for Unused Pins .....	12
3.4	Hints for Alternate Pin Functions .....	12
<b>4</b>	<b>General Product Characteristics</b> .....	<b>13</b>
4.1	Absolute Maximum Ratings .....	13
4.2	Functional Range .....	15
4.3	Thermal Resistance .....	16
4.4	Current Consumption .....	17
<b>5</b>	<b>System Features</b> .....	<b>21</b>
5.1	Block Description of State Machine .....	22
5.1.1	Device Configuration and SBC Init Mode .....	23
5.1.1.1	Device Configuration .....	23
5.1.1.2	SBC Init Mode .....	26
5.1.2	SBC Normal Mode .....	27
5.1.3	SBC Stop Mode .....	28
5.1.4	SBC Sleep Mode .....	29
5.1.5	SBC Restart Mode .....	30
5.1.6	SBC Fail-Safe Mode .....	31
5.1.7	SBC Development Mode .....	32
5.2	Wake Features .....	34
5.2.1	Cyclic Sense .....	34
5.2.1.1	Configuration and Operation of Cyclic Sense .....	35
5.2.1.2	Cyclic Sense in Low Power Mode .....	38
5.2.2	Cyclic Wake .....	39
5.2.3	Internal Timer .....	40
5.3	Supervision Features .....	40
<b>6</b>	<b>Voltage Regulator 1</b> .....	<b>41</b>
6.1	Block Description .....	41
6.2	Functional Description .....	42
6.3	Electrical Characteristics .....	43
<b>7</b>	<b>Voltage Regulator 2</b> .....	<b>46</b>
7.1	Block Description .....	46
7.2	Functional Description .....	47
7.2.1	Short to Battery Protection .....	47
7.3	Electrical Characteristics .....	48
<b>8</b>	<b>External Voltage Regulator 3</b> .....	<b>51</b>
8.1	Block Description .....	51
8.2	Functional Description .....	52
8.2.1	External Voltage Regulator as Independent Voltage Regulator .....	53
8.2.2	External Voltage Regulator in Load Sharing Mode .....	54

8.3	External Components .....	55
8.4	Calculation of $R_{SHUNT}$ .....	56
8.5	Unused Pins .....	56
8.6	Electrical Characteristics .....	57
<b>9</b>	<b>High-Side Switch .....</b>	<b>62</b>
9.1	Block Description .....	62
9.2	Functional Description .....	62
9.2.1	Over- and Undervoltage Switch Off .....	63
9.2.2	Overcurrent Detection and Switch Off .....	63
9.2.3	Open Load Detection .....	63
9.2.4	HSx Operation in Different SBC Modes .....	63
9.2.5	PWM and Timer Function .....	64
9.3	Electrical Characteristics .....	65
<b>10</b>	<b>High Speed CAN Transceiver .....</b>	<b>66</b>
10.1	Block Description .....	66
10.2	Functional Description .....	66
10.2.1	CAN OFF Mode .....	68
10.2.2	CAN Normal Mode .....	68
10.2.3	CAN Receive Only Mode .....	69
10.2.4	CAN Wake Capable Mode .....	69
10.2.5	TXD Time-out Feature .....	72
10.2.6	Bus Dominant Clamping .....	72
10.2.7	Undervoltage Detection .....	72
10.3	Electrical Characteristics .....	73
<b>11</b>	<b>LIN Transceiver .....</b>	<b>80</b>
11.1	Block Description .....	80
11.1.1	LIN Specifications .....	80
11.2	Functional Description .....	81
11.2.1	LIN OFF Mode .....	81
11.2.2	LIN Normal Mode .....	82
11.2.3	LIN Receive Only Mode .....	82
11.2.4	LIN Wake Capable Mode .....	83
11.2.5	TXD Time-out Feature .....	84
11.2.6	Bus Dominant Clamping .....	84
11.2.7	Undervoltage Detection .....	84
11.2.8	Slope Selection .....	85
11.2.9	Flash Programming via LIN .....	85
11.3	Electrical Characteristics .....	86
<b>12</b>	<b>Wake and Voltage Monitoring Inputs .....</b>	<b>91</b>
12.1	Block Description .....	91
12.2	Functional Description .....	92
12.2.1	Wake Input Configuration .....	93
12.2.2	Alternate Measurement Function with WK1 and WK2 .....	95
12.2.2.1	Block Description .....	95
12.2.2.2	Functional Description .....	95
12.3	Electrical Characteristics .....	96

<b>13</b>	<b>Interrupt Function</b>	<b>98</b>
13.1	Block and Functional Description	98
13.2	Electrical Characteristics	100
<b>14</b>	<b>Fail Outputs</b>	<b>101</b>
14.1	Block and Functional Description	101
14.1.1	General Purpose I/O Functionality of FO2 and FO3 as Alternate Function	102
14.2	Electrical Characteristics	104
<b>15</b>	<b>Supervision Functions</b>	<b>106</b>
15.1	Reset Function	106
15.1.1	Reset Output Description	106
15.1.2	Soft Reset Description	107
15.2	Watchdog Function	108
15.2.1	Time-Out Watchdog	109
15.2.2	Window Watchdog	110
15.2.3	Watchdog Setting Check Sum	111
15.2.4	Watchdog during SBC Stop Mode	112
15.2.5	Watchdog Start in SBC Stop Mode due to Bus Wake	113
15.3	VS Power On Reset	114
15.4	Undervoltage VS and VSHS	115
15.5	Overvoltage VSHS	115
15.6	VCC1 Over-/ Undervoltage and Undervoltage Prewarning	115
15.6.1	VCC1 Undervoltage and Undervoltage Prewarning	115
15.6.2	VCC1 Overvoltage	116
15.7	VCC1 Short Circuit and VCC3 Diagnostics	117
15.8	VCC2 Undervoltage and VCAN Undervoltage	117
15.9	Thermal Protection	118
15.9.1	Individual Thermal Shutdown	118
15.9.2	Temperature Prewarning	119
15.9.3	SBC Thermal Shutdown	119
15.10	Electrical Characteristics	120
<b>16</b>	<b>Serial Peripheral Interface</b>	<b>124</b>
16.1	SPI Block Description	124
16.2	Failure Signalization in the SPI Data Output	125
16.3	SPI Programming	127
16.4	SPI Bit Mapping	129
16.5	SPI Control Registers	132
16.5.1	General Control Registers	133
16.6	SPI Status Information Registers	151
16.6.1	General Status Registers	152
16.6.2	Family and Product Information Register	163
16.7	Electrical Characteristics	164
<b>17</b>	<b>Application Information</b>	<b>166</b>
17.1	Application Diagram	166
17.2	ESD Tests	171
17.3	Thermal Behavior of Package	172
<b>18</b>	<b>Package Outlines</b>	<b>174</b>

---

**19**      **Revision History** ..... **175**

---

## Overview

# 1 Overview

### Scalable System Basis Chip Family

- Product family with various products for complete scalable application coverage.
- Dedicated Data Sheets are available for the different product variants
- Complete compatibility (hardware and software) across the family
- TLE9263 with 2 LIN transceivers, 3 voltage regulators
- TLE9262 with 1 LIN transceiver, 3 voltage regulators
- TLE9261 without LIN transceivers, 3 voltage regulators
- Product variants for 5V (TLE926xQX) and 3.3V (TLE926xQXV33) output voltage for main voltage regulator
- CAN Partial Networking variants for 5V (TLE926x-3QX) and 3.3V (TLE926x-3QXV33) output voltage

### Device Description

The TLE9263BQXV33 is a monolithic integrated circuit in an exposed pad VQFN-48 (7mm x 7mm) power package with Lead Tip Inspection (LTI) feature to support Automatic Optical Inspection (AOI).

The device is designed for various CAN-LIN automotive applications as main supply for the microcontroller and as interface for a LIN and CAN bus network.

To support these applications, the System Basis Chip (SBC) provides the main functions, such as a 3.3V low-dropout voltage regulator (LDO) for e.g. a microcontroller supply, another 5V low-dropout voltage regulator with off-board protection for e.g. sensor supply, another 3.3V/1.8V regulator to drive an external PNP transistor, which can be used as an independent supply for off-board usage or in load sharing configuration with the main regulator VCC1, a HS-CAN transceiver supporting CAN FD and LIN transceiver for data transmission, high-side switches with embedded protective functions and a 16-bit Serial Peripheral Interface (SPI) to control and monitor the device. Also implemented are a configurable timeout / window watchdog circuit with a reset feature, three Fail Outputs and an undervoltage reset feature.

The device offers low-power modes in order to minimize current consumption on applications that are connected permanently to the battery. A wake-up from the low-power mode is possible via a message on the buses, via the bi-level sensitive monitoring/wake-up inputs as well as via cyclic wake.

The device is designed to withstand the severe conditions of automotive applications.

---

## Overview

### Product Features

- Very low quiescent current consumption in Stop- and Sleep Mode
- Periodic Cyclic Wake in SBC Normal- and Stop Mode
- Periodic Cyclic Sense in SBC Normal-, Stop- and Sleep Mode
- Low-Drop Voltage Regulator 3.3V, 250mA
- Low-Drop Voltage Regulator 5V, 100mA, protected features for off-board usage
- Low-Drop Voltage Regulator, driving an external PNP transistor - 3.3V in load sharing configuration or 3.3V/1.8V in stand-alone configuration, protected features for off-board usage. Current limitation by shunt resistor (up to 350mA with 470mΩ external shunt resistor) in stand-alone configuration
- High-Speed CAN Transceiver:
  - fully compliant to HS-CAN standard ISO 11898-2:2016
  - supporting CAN FD communication up to 5 Mbps
- Two LIN Transceivers LIN 2.2a, J2602 with configurable TXD timeout feature and LIN Flash Mode
- Fully compliant to “Hardware Requirements for LIN, CAN and FlexRay Interfaces in Automotive Applications” Revision 1.3, 2012-05-04
- Four High-Side Outputs 7Ω typ.
- Dedicated supply pin for High-Side Outputs
- Two General Purpose High-Voltage In- and Outputs (GPIOs) configurable as add. Fail Outputs, Wake Inputs, Low-Side switches or High-Side switches
- Three universal High-Voltage Wake Inputs for voltage level monitoring
- Alternate High-Voltage Measurement Function, e.g. for battery voltage sensing
- Configurable wake-up sources
- Reset Output
- Configurable timeout and window watchdog
- Up to three Fail Outputs (depending on configuration)
- Overtemperature and short circuit protection feature
- Wide supply input voltage and temperature range
- Software compatible to all SBC families TLE926x and TLE927x
- Green Product (RoHS compliant) & AEC Qualified
- PG-VQFN-48 leadless exposed-pad power package with Lead Tip Inspection (LTI) feature to support Automatic Optical Inspection (AOI)

Block Diagram

2 Block Diagram

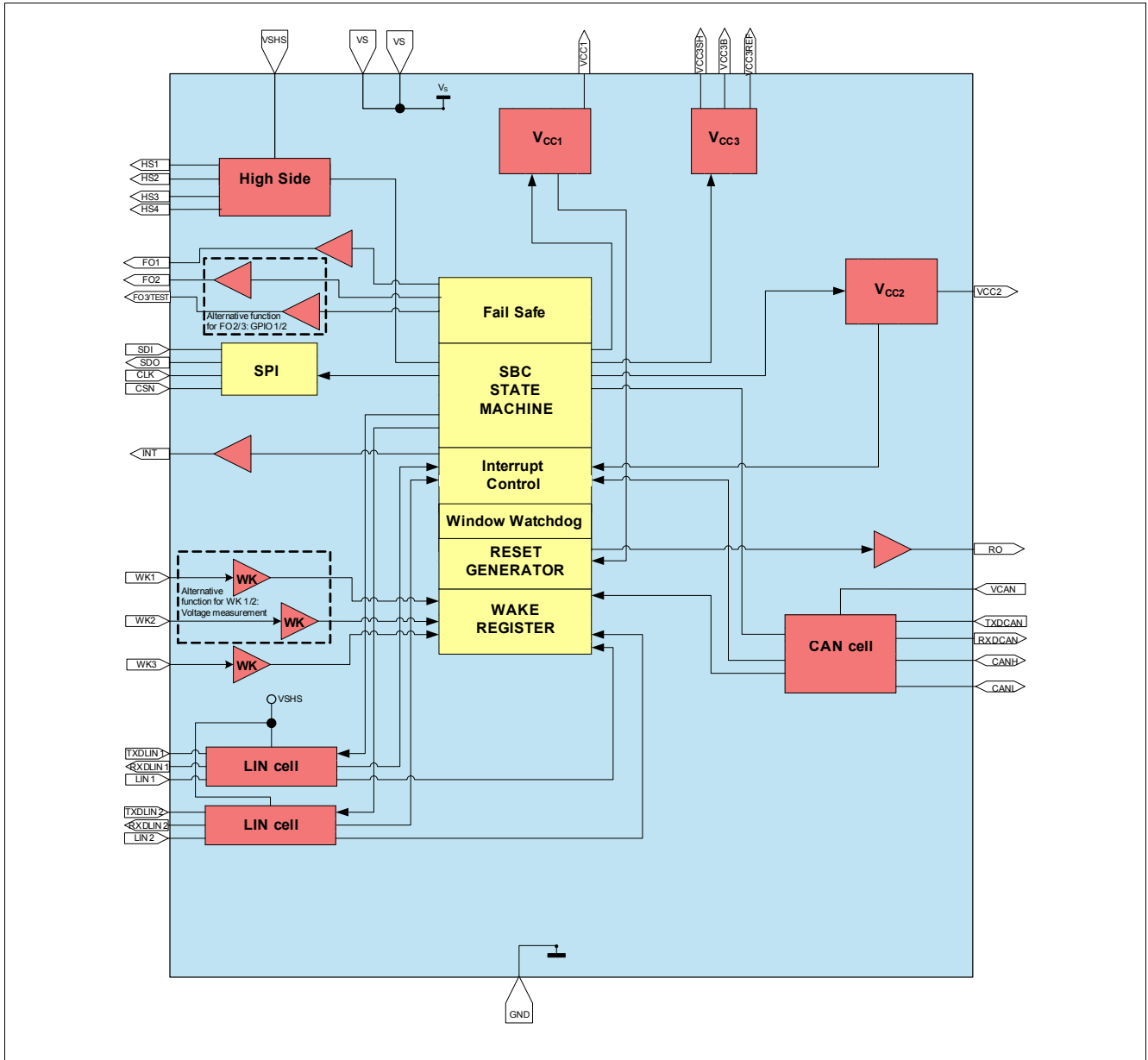


Figure 1 Block Diagram



Pin Configuration

3 Pin Configuration

3.1 Pin Assignment

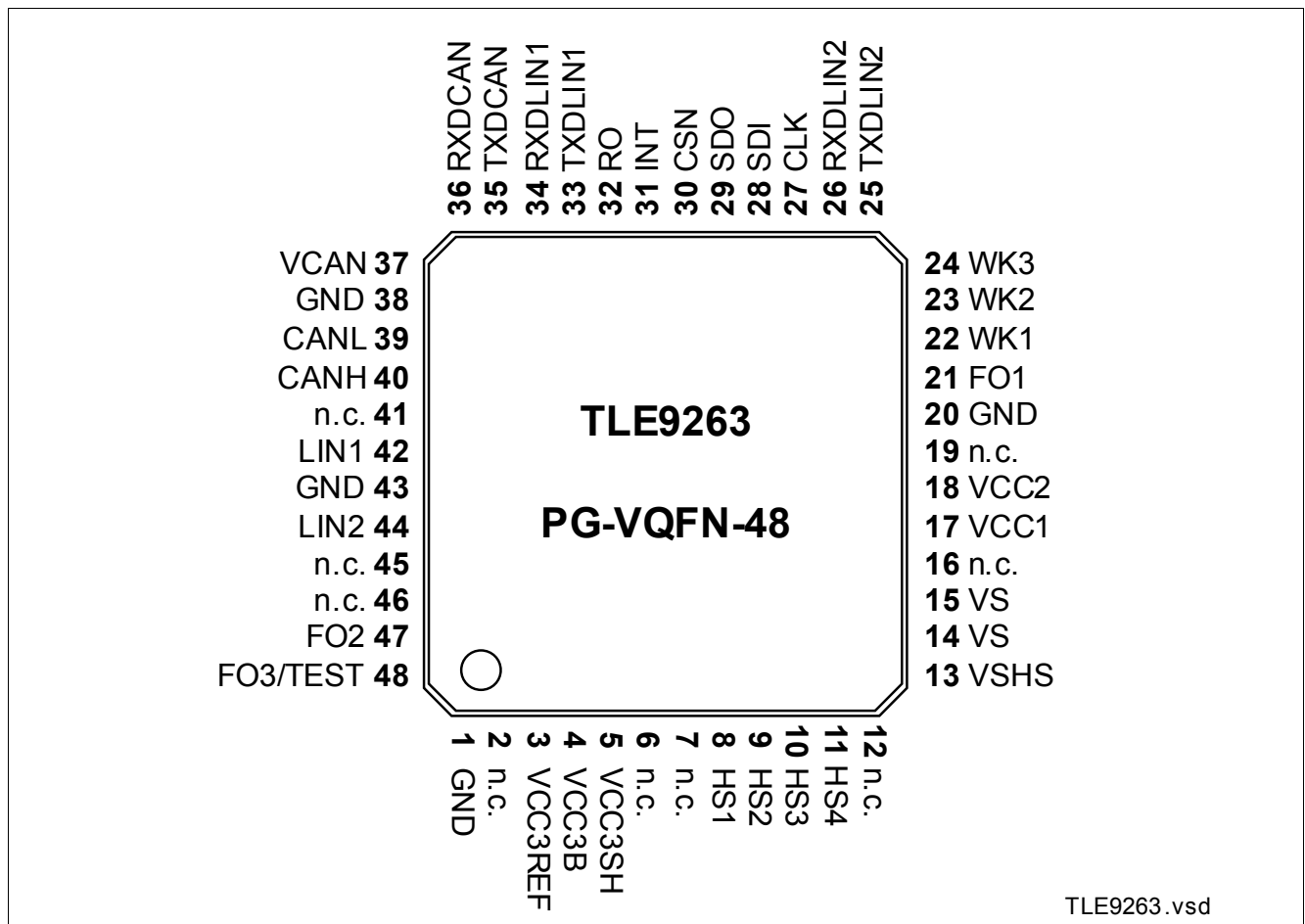


Figure 2 Pin Configuration

## Pin Configuration

### 3.2 Pin Definitions and Functions

Pin	Symbol	Function
1	GND	<b>Ground</b>
2	n.c.	<b>not connected</b> ; internally not bonded.
3	VCC3REF	<b>VCC3REF</b> ; Collector connection for external PNP, reference input
4	VCC3B	<b>VCC3B</b> ; Base connection for external PNP
5	VCC3SH	<b>VCC3SH</b> ; Emitter connection for external PNP, shunt connection
6	n.c.	<b>not connected</b> ; internally not bonded.
7	n.c.	<b>not connected</b> ; internally not bonded.
8	HS1	<b>High Side Output 1</b> ; typ. 7Ω
9	HS2	<b>High Side Output 2</b> ; typ. 7Ω
10	HS3	<b>High Side Output 3</b> ; typ. 7Ω
11	HS4	<b>High Side Output 4</b> ; typ. 7Ω
12	n.c	<b>not connected</b> ; internally not bonded.
13	VSHS	<b>Supply Voltage HS, LIN and GPIO1/2 in HS configuration; Supply voltage for High-Side Switches and LIN modules and respective UV-/OV supervision; Connected to battery voltage with reverse protection diode and filter against EMC; connect to VS if separate supply is not needed</b>
14	VS	<b>Supply Voltage; Supply voltage for chip internal supply and voltage regulators; Connected to Battery Voltage with external reverse protection Diode and Filter against EMC</b>
15	VS	<b>Supply Voltage; Supply voltage for chip internal supply and voltage regulators; Connected to Battery Voltage with external reverse protection Diode and Filter against EMC</b>
16	n.c.	<b>not connected</b> ; internally not bonded.
17	VCC1	<b>Voltage Regulator Output 1</b>
18	VCC2	<b>Voltage Regulator Output 2</b>
19	n.c.	<b>not connected</b> ; internally not bonded.
20	GND	<b>GND</b>
21	FO1	<b>Fail Output 1</b>
22	WK1	<b>Wake Input 1</b> ; Alternative function: HV-measurement function input pin (only in combination with WK2, see <a href="#">Chapter 12.2.2</a> )
23	WK2	<b>Wake Input 2</b> ; Alternative function: HV-measurement function output pin (only in combination with WK1, see <a href="#">Chapter 12.2.2</a> )
24	WK3	<b>Wake Input 3</b>
25	TXDLIN2	<b>Transmit LIN2</b>
26	RXDLIN2	<b>Receive LIN2</b>
27	CLK	<b>SPI Clock Input</b>
28	SDI	<b>SPI Data Input; into SBC (=MOSI)</b>
29	SDO	<b>SPI Data Output; out of SBC (=MISO)</b>

## Pin Configuration

Pin	Symbol	Function
30	CSN	<b>SPI Chip Select Not Input</b>
31	INT	<b>Interrupt Output</b> ; used as wake-up flag for microcontroller in SBC Stop or Normal Mode and for indicating failures. Active low. During start-up used to set the SBC configuration. External pull-up sets config 1/3, no external pull-up sets config 2/4.
32	RO	<b>Reset Output</b>
33	TXDLIN1	<b>Transmit LIN1</b>
34	RXDLIN1	<b>Receive LIN1</b>
35	TXDCAN	<b>Transmit CAN</b>
36	RXDCAN	<b>Receive CAN</b>
37	VCAN	<b>Supply Input; for internal HS-CAN cell</b>
38	GND	<b>GND</b>
39	CANL	<b>CAN Low Bus Pin</b>
40	CANH	<b>CAN High Bus Pin</b>
41	n.c.	<b>not connected</b> ; internally not bonded.
42	LIN1	<b>LIN1 Bus</b> ; Bus line for the LIN interface, according to ISO. 9141 and LIN specification 2.2 as well as SAE J2602-2.
43	GND	<b>Ground</b>
44	LIN2	<b>LIN2 Bus</b> ; Bus line for the LIN interface, according to ISO. 9141 and LIN specification 2.2 as well as SAE J2602-2.
45	n.c.	<b>not connected</b> ; internally not bonded.
46	n.c.	<b>not connected</b> ; internally not bonded.
47	FO2	<b>Fail Output 2</b> - Side Indicator; Side indicators 1.25Hz 50% duty cycle output; Open drain. Active LOW. <b>Alternative Function: GPIO1</b> ; configurable pin as WK, or LS, or HS supplied by VSHS (default is FO2, see also <a href="#">Chapter 14.1.1</a> )
48	FO3/TEST	<b>Fail Output 3</b> - Pulsed Light Output; Break/rear light 100Hz 20% duty cycle output; Open drain. Active LOW <b>TEST</b> ; Connect to GND to activate SBC Development Mode; Integrated pull-up resistor. Connect to VS with pull-up resistor or leave open for normal operation. <b>Alternative Function: GPIO2</b> ; configurable pin as WK, or LS, or HS supplied by VSHS (default is FO3, see also <a href="#">Chapter 14.1.1</a> )
Cooling Tab	GND	Cooling Tab - Exposed Die Pad; For cooling purposes only, do not use as an electrical ground. <sup>1)</sup>

- 1) The exposed die pad at the bottom of the package allows better power dissipation of heat from the SBC via the PCB. The exposed die pad is not connected to any active part of the IC and can be left floating or it can be connected to GND (recommended) for the best EMC performance.

**Note:** *all VS Pins must be connected to battery potential or insert a reverse polarity diodes where required; all GND pins as well as the Cooling Tab must be connected to one common GND potential; note that the tie bars at each package corner are connected to the cooling tab (see also [Chapter 18](#))*

## Pin Configuration

### 3.3 Hints for Unused Pins

It must be ensured that the correct configurations are also selected, i.e. in case functions are not used that they are disabled via SPI:

- WK1/2/3: connect to GND and disable WK inputs via SPI
- HSx: leave open
- LINx, RXDLINx, TXDLINx, CANH/L, RXDCAN, TXDCAN: leave all pins open
- RO / FOx: leave open
- INT: leave open
- TEST: connect to GND during power-up to activate SBC Development Mode; connect to VS or leave open for normal user mode operation
- VCC2: leave open and keep disabled
- VCC3: See [Chapter 8.5](#)
- VCAN: connect to VCC1
- n.c.: not connected; internally not bonded; connect to GND
- If unused pins are routed to an external connector which leaves the ECU, then these pins should have provision for a zero ohm jumper (depopulated if unused) or ESD protection.

### 3.4 Hints for Alternate Pin Functions

In case of alternate pin functions, selectable via SPI, it must be ensured that the correct configurations are also selected via SPI, in case it is not done automatically. Please consult the respective chapter. In addition, following topics shall be considered:

- WK1..2: The pins can be either used as HV wake / voltage monitoring inputs or for a voltage measurement function (via bit [WK\\_MEAS](#)). In the second case, the WK1..2 pins shall not be used / assigned for any wake detection nor cyclic sense functionality, i.e. WK1 and WK2 must be disabled in the register [WK\\_CTRL\\_2](#) and the level information is to be ignored in the register [WK\\_LVL\\_STAT](#).
- FO2..3: The pins can also be configured as GPIOs in the [GPIO\\_CTRL](#) register. In this case, the pins shall not be used for any fail output functionality. The default function after Power on Reset (POR) is FOx.

## 4 General Product Characteristics

### 4.1 Absolute Maximum Ratings

**Table 1 Absolute Maximum Ratings<sup>1)</sup>**

$T_j = -40\text{ °C}$  to  $+150\text{ °C}$ ; all voltages with respect to ground, positive current flowing into pin (unless otherwise specified)

Parameter	Symbol	Values			Unit	Note / Test Condition	Number
		Min.	Typ.	Max.			
<b>Voltages</b>							
Supply Voltage (VS, VSHS)	$V_{S_x, \max}$	-0.3	–	28	V	–	P_4.1.1
Supply Voltage (VS, VSHS)	$V_{S_x, \max}$	-0.3	–	40	V	Load Dump, max. 400 ms	P_4.1.2
Voltage Regulator 1	$V_{CC1, \max}$	-0.3	–	5.5	V	–	P_4.1.3
Voltage Regulator 2	$V_{CC2, \max}$	-0.3	–	28	V	$V_{CC2} = 40V$ for Load Dump, max. 400 ms;	P_4.1.4
Voltage Regulator 3 (VCC3REF)	$V_{CC3REF, \max}$	-0.3	–	28	V	$V_{CC3REF} = 40V$ for Load Dump, max. 400 ms;	P_4.1.5
Voltage Regulator 3 (VCC3B)	$V_{CC3B, \max}$	-0.3	–	$V_S + 10$	V	$V_{CC3B} = 40V$ for Load Dump, max. 400 ms;	P_4.1.25
Voltage Regulator 3 (VCC3SH)	$V_{CC3SH, \max}$	$V_S - 0.30$	–	$V_S + 0.30$	V	–	P_4.1.26
Wake Inputs WK1..3	$V_{WK, \max}$	-0.3	–	40	V	–	P_4.1.6
Fail Pin FO1	$V_{FO1, \max}$	-0.3	–	40	V	–	P_4.1.7
Fail Pins FO2, FO3/TEST	$V_{FO2\_3, \max}$	-0.3	–	$V_S + 0.3$	V	–	P_4.1.23
LINx, CANH, CANL	$V_{BUS, \max}$	-27	–	40	V	–	P_4.1.8
Maximum Differential CAN Bus Voltage	$V_{CAN\_Diff, \max}$	-5	–	10	V	–	P_4.1.27
Logic Input Pins (CSN, CLK, SDI, TXDLINx, TXDCAN)	$V_{I, \max}$	-0.3	–	$V_{CC1} + 0.3$	V	–	P_4.1.9
Logic Output Pins (SDO, RO, INT, RXDLINx, RXDCAN)	$V_{O, \max}$	-0.3	–	$V_{CC1} + 0.3$	V	–	P_4.1.10
VCAN Input Voltage	$V_{VCAN, \max}$	-0.3	–	5.5	V	–	P_4.1.11
High Side 1..4	$V_{HS, \max}$	-0.3	–	$V_{SHS} + 0.3$	V	–	P_4.1.12
<b>Currents</b>							
Wake input WK1	$I_{WK1, \max}$	0	–	500	$\mu A$	<sup>2)</sup>	P_4.1.13
Wake input WK2	$I_{WK2, \max}$	-500	–	0	$\mu A$	<sup>2)</sup>	P_4.1.14

**Table 1 Absolute Maximum Ratings<sup>1)</sup>** (cont'd)

$T_j = -40\text{ °C}$  to  $+150\text{ °C}$ ; all voltages with respect to ground, positive current flowing into pin (unless otherwise specified)

Parameter	Symbol	Values			Unit	Note / Test Condition	Number
		Min.	Typ.	Max.			
<b>Temperatures</b>							
Junction Temperature	$T_j$	-40	–	150	°C	–	P_4.1.15
Storage Temperature	$T_{stg}$	-55	–	150	°C	–	P_4.1.16
<b>ESD Susceptibility</b>							
ESD Resistivity	$V_{ESD,11}$	-2	–	2	kV	HBM <sup>3)</sup>	P_4.1.17
ESD Resistivity to GND, HSx	$V_{ESD,12}$	-2	–	2	kV	HBM <sup>3)</sup>	P_4.1.18
ESD Resistivity to GND, CANH, CANL, LINx	$V_{ESD,13}$	-8	–	8	kV	HBM <sup>4)3)</sup>	P_4.1.19
ESD Resistivity to GND	$V_{ESD,21}$	-500	–	500	V	CDM <sup>5)</sup>	P_4.1.20
ESD Resistivity Pin 1, 12,13,24,25,36,37,48 (corner pins) to GND	$V_{ESD,22}$	-750	–	750	V	CDM <sup>5)</sup>	P_4.1.21

1) Not subject to production test, specified by design.

2) Applies only if WK1 and WK2 are configured as alternative HV-measurement function

3) ESD susceptibility, HBM according to ANSI/ESDA/JEDEC JS-001 (1.5 kΩ, 100 pF)

4) For ESD “GUN” Resistivity 6kV (according to IEC61000-4-2 “gun test” (150pF, 330Ω)), will be shown in Application Information and test report will be provided from IBEE

5) ESD susceptibility, Charged Device Model “CDM” EIA/JESD22-C101 or ESDA STM5.3.1

**Notes**

1. Stresses above the ones listed here may cause permanent damage to the device. Exposure to absolute maximum rating conditions for extended periods may affect device reliability.
2. Integrated protection functions are designed to prevent IC destruction under fault conditions described in the data sheet. Fault conditions are considered as “outside” normal operating range. Protection functions are not designed for continuous repetitive operation.

## 4.2 Functional Range

**Table 2 Functional Range**

Parameter	Symbol	Values			Unit	Note / Test Condition	Number
		Min.	Typ.	Max.			
Supply Voltage	$V_{S,func}$	$V_{POR}$	–	28	V	<sup>1)</sup> $V_{POR}$ see section <a href="#">Chapter 15.10</a>	P_4.2.1
LIN Bus Voltage	$V_{S,LIN,func}$	6	–	18	V	<sup>2)</sup>	P_4.2.2
CAN Supply Voltage	$V_{CAN,func}$	4.75	–	5.25	V	–	P_4.2.3
SPI frequency	$f_{SPI}$	–	–	4	MHz	see <a href="#">Chapter 16.7</a> for $f_{SPI,max}$	P_4.2.4
Junction Temperature	$T_j$	-40	–	150	°C	–	P_4.2.5

1) Including Power-On Reset, Over- and Undervoltage Protection

2) Parameter Specification according to LIN 2.2 standard

*Note: Within the functional range the IC operates as described in the circuit description. The electrical characteristics are specified within the conditions given in the related electrical characteristics table.*

### Device Behavior Outside of Specified Functional Range:

- $28V < V_{S,func} < 40V$ : Device will still be functional including the state machine; the specified electrical characteristics might not be ensured anymore. The regulators VCC1/2/3 are working properly, however, a thermal shutdown might occur due to high power dissipation. HSx switches might be turned OFF depending on VSHS\_OV configurations. The specified SPI communication speed is ensured; the absolute maximum ratings are not violated, however the device is not intended for continuous operation of  $V_S > 28V$ . The device operation at high junction temperatures for long periods might reduce the operating life time;
- $18V < V_{S,LIN} < 28V$ : The LIN transceiver is still functional. However, the communication might fail due to out-of-LIN-spec operation;
- $V_{SHS,UVD} < V_{S,LIN} < 6V$ : The LIN transceiver is still functional. However, the communication might fail due to out-of-LIN-spec operation;
- $V_{CAN} < 4.75V$ : The undervoltage bit **VCAN\_UV** will be set in the SPI register **BUS\_STAT\_1** and the transmitter will be disabled as long as the UV condition is present;
- $5.25V < V_{CAN} < 5.50V$ : CAN transceiver still functional. However, the communication might fail due to out-of-spec operation;
- $V_{POR,f} < V_S < 5.5V$ : Device will still be functional; the specified electrical characteristics might not be ensured anymore.
  - The voltage regulators will enter the low-drop operation mode (applies for VCC3 only if bit **VCC3\_VS\_UV\_OFF** is set),
  - A VCC1\_UV reset could be triggered depending on the Vrtx settings,
  - The LIN transmitter will be disabled if  $V_{SHS,UVD}$  is reached,
  - HSx switch behavior will depend on the respective configuration:
    - **HS\_UV\_SD\_EN** = '0' (default): HSx will be turned OFF for  $V_{SHS} < V_{SHS\_UV}$  and will stay OFF;
    - **HS\_UV\_SD\_EN** = '1': HSx stays on as long as possible. An unwanted overcurrent shut down may occur. OC shut down bit set and the respective HSx switch will stay OFF;
  - FOx outputs will remain ON if they were enabled before  $V_S > 5.5V$ ,
  - The specified SPI communication speed is ensured.

### 4.3 Thermal Resistance

**Table 3 Thermal Resistance<sup>1)</sup>**

Parameter	Symbol	Values			Unit	Note / Test Condition	Number
		Min.	Typ.	Max.			
Junction to Soldering Point	$R_{thJSP}$	–	6	–	K/W	Exposed Pad	P_4.3.1
Junction to Ambient	$R_{thJA}$	–	33	–	K/W	<sup>2)</sup>	P_4.3.2

1) Not subject to production test, specified by design.

2) According to Jedec JESD51-2,-5,-7 at natural convection on FR4 2s2p board for 1.5W. Board: 76.2x14.3x1.5mm<sup>3</sup> with 2 inner copper layers (35µm thick), with thermal via array under the exposed pad contacting the first inner copper layer and 300mm<sup>2</sup> cooling area on the bottom layer (70µm).



## 4.4 Current Consumption

**Table 4 Current Consumption**

Current consumption values are specified at  $T_j = 25^\circ\text{C}$ ,  $V_S = 13.5\text{V}$ , all outputs open (unless otherwise specified)

Parameter	Symbol	Values			Unit	Note / Test Condition	Number
		Min.	Typ.	Max.			
<b>SBC Normal Mode</b>							
Normal Mode current consumption	$I_{\text{Normal}}$	–	3.5	6.5	mA	$V_S = 5.5\text{ V to }28\text{ V}$ ; $T_j = -40\text{ }^\circ\text{C to }+150\text{ }^\circ\text{C}$ ; VCC2, CAN, LIN, VCC3, HSx = OFF	P_4.4.1
<b>SBC Stop Mode</b>							
Stop Mode current consumption	$I_{\text{Stop}_{1,25}}$	–	44	60	$\mu\text{A}$	<sup>1)</sup> VCC2/3, HSx = OFF; CAN, LINx, WKx not wake capable; Watchdog = OFF; no load on VCC1; <b>I_PEAK_TH = '0'</b>	P_4.4.2
Stop Mode current consumption	$I_{\text{Stop}_{1,85}}$	–	50	70	$\mu\text{A}$	<sup>1)2)</sup> $T_j = 85^\circ\text{C}$ ; VCC2/3, HSx = OFF; CAN, LINx, WKx not wake capable; Watchdog = OFF; no load on VCC1; <b>I_PEAK_TH = '0'</b>	P_4.4.3
Stop Mode current consumption (high active peak threshold)	$I_{\text{Stop}_{2,25}}$	–	64	90	$\mu\text{A}$	<sup>1)</sup> VCC2/3, HSx = OFF; CAN, LINx, WKx not wake capable; Watchdog = OFF; no load on VCC1; <b>I_PEAK_TH = '1'</b>	P_4.4.35
Stop Mode current consumption (high active peak threshold)	$I_{\text{Stop}_{2,85}}$	–	70	100	$\mu\text{A}$	<sup>1)2)</sup> $T_j = 85^\circ\text{C}$ ; VCC2/3, HSx = OFF; CAN, LINx, WKx not wake capable; Watchdog = OFF; no load on VCC1; <b>I_PEAK_TH = '1'</b>	P_4.4.36
<b>SBC Sleep Mode</b>							
Sleep Mode current consumption	$I_{\text{Sleep}_{25}}$	–	15	25	$\mu\text{A}$	VCC2/3, HSx = OFF; CAN, LINx, WKx not wake capable	P_4.4.5
Sleep Mode current consumption	$I_{\text{Sleep}_{85}}$	–	25	35	$\mu\text{A}$	<sup>2)</sup> $T_j = 85^\circ\text{C}$ ; VCC2/3, HSx = OFF; CAN, LINx, WKx not wake capable	P_4.4.6

**General Product Characteristics**
**Table 4 Current Consumption (cont'd)**

 Current consumption values are specified at  $T_j = 25^\circ\text{C}$ ,  $V_S = 13.5\text{V}$ , all outputs open (unless otherwise specified)

Parameter	Symbol	Values			Unit	Note / Test Condition	Number
		Min.	Typ.	Max.			
<b>Feature Incremental Current Consumption</b>							
Current consumption for CAN module, recessive state	$I_{\text{CAN,rec}}$	–	2	3	mA	SBC Normal/Stop Mode; CAN Normal Mode; VCC1 connected to VCAN; VTXDCAN = VCC1; no RL on CAN	P_4.4.7
Current consumption for CAN module, dominant state	$I_{\text{CAN,dom}}$	–	3	4.5	mA	<sup>2)</sup> SBC Normal/Stop Mode; CAN Normal Mode; VCC1 connected to VCAN; VTXDCAN = GND; no RL on CAN	P_4.4.8
Current consumption for CAN module, Receive Only Mode	$I_{\text{CAN,RcvOnly}}$	–	0.9	1.2	mA	<sup>2)</sup> SBC Normal/Stop Mode; CAN Receive Only Mode; VCC1 connected to VCAN; VTXDCAN = VCC1; no RL on CAN	P_4.4.9
Current consumption per LIN module, recessive state	$I_{\text{LIN,rec}}$	–	0.1	1	mA	SBC Normal/Stop Mode; LIN Normal Mode; VTXDLIN = VCC1; no RL on LIN	P_4.4.10
Current consumption per LIN module, dominant state	$I_{\text{LIN,dom}}$	–	1.0	1.5	mA	<sup>2)</sup> SBC Normal/Stop Mode; LIN Normal Mode; VTXDLIN = GND; no RL on LIN	P_4.4.11
Current consumption per LIN module, Receive Only Mode	$I_{\text{LIN,RcvOnly}}$	–	0.2	0.5	mA	<sup>2)</sup> SBC Normal/Stop Mode; LIN Receive Only Mode; VTXDLIN = VCC1; no RL on LIN	P_4.4.12
Current consumption for WK1..3 wake capability (all wake inputs)	$I_{\text{Wake,WKx,25}}$	–	0.2	2	$\mu\text{A}$	<sup>3)4)5)</sup> SBC Sleep Mode; WK1..3 wake capable (all WKx enabled); LIN, CAN = OFF	P_4.4.13
Current consumption for WK1..3 wake capability (all wake inputs)	$I_{\text{Wake,WKx,85}}$	–	0.5	3	$\mu\text{A}$	<sup>2)3)4)5)</sup> SBC Sleep Mode; $T_j = 85^\circ\text{C}$ ; WK1..3 wake capable; (all WKx enabled); LIN, CAN = OFF	P_4.4.14

**General Product Characteristics**
**Table 4 Current Consumption (cont'd)**

 Current consumption values are specified at  $T_j = 25^\circ\text{C}$ ,  $V_S = 13.5\text{V}$ , all outputs open (unless otherwise specified)

Parameter	Symbol	Values			Unit	Note / Test Condition	Number
		Min.	Typ.	Max.			
Current consumption per LIN module wake capability	$I_{\text{Wake,LIN},25}$	–	0.2	2	$\mu\text{A}$	<sup>3)</sup> SBC Sleep Mode; LIN wake capable; WK1..3, CAN = OFF	P_4.4.15
Current consumption per LIN module wake capability	$I_{\text{Wake,LIN},85}$	–	0.5	3	$\mu\text{A}$	<sup>2)3)</sup> SBC Sleep Mode; $T_j = 85^\circ\text{C}$ ; LIN wake capable; WK1..3, CAN = OFF	P_4.4.16
Current consumption for CAN wake capability	$I_{\text{Wake,CAN},25}$	–	4.5	6	$\mu\text{A}$	<sup>3)</sup> SBC Sleep Mode; CAN wake capable; WK1..3, LIN = OFF	P_4.4.17
Current consumption for CAN wake capability	$I_{\text{Wake,CAN},85}$	–	5.5	7	$\mu\text{A}$	<sup>2)3)</sup> SBC Sleep Mode; $T_j = 85^\circ\text{C}$ ; CAN wake capable; WK1..3, LIN = OFF	P_4.4.18
VCC2 Normal Mode current consumption	$I_{\text{Normal,VCC2}}$	–	2.5	3.5	mA	$V_S = 5.5\text{ V to } 28\text{ V}$ ; $T_j = -40^\circ\text{C to } +150^\circ\text{C}$ ; VCC2 = ON (no load)	P_4.4.32
Current consumption for VCC2 in SBC Sleep Mode	$I_{\text{Sleep,VCC2},25}$	–	25	35	$\mu\text{A}$	<sup>1)3)</sup> SBC Sleep Mode; VCC2 = ON (no load); LIN, CAN, WK1..3 = OFF	P_4.4.19
Current consumption for VCC2 in SBC Sleep Mode	$I_{\text{Sleep,VCC2},85}$	–	30	40	$\mu\text{A}$	<sup>1)2)3)</sup> SBC Sleep Mode; $T_j = 85^\circ\text{C}$ ; VCC2 = ON (no load); LIN, CAN, WK1..3 = OFF	P_4.4.20
Current consumption for VCC3 in SBC Sleep Mode in stand-alone configuration	$I_{\text{Sleep,VCC3},25}$	–	40	60	$\mu\text{A}$	<sup>1)3)</sup> SBC Sleep Mode; VCC3 = ON (no load, stand-alone config.); LIN, CAN, WK1..3 = OFF	P_4.4.21
Current consumption for VCC3 in SBC Sleep Mode in stand-alone configuration	$I_{\text{Sleep,VCC3},85}$	–	50	70	$\mu\text{A}$	<sup>1)2)3)</sup> SBC Sleep Mode; $T_j = 85^\circ\text{C}$ ; VCC3 = ON (no load, stand-alone config.); LIN, CAN, WK1..3 = OFF	P_4.4.22
Current consumption for HSx in SBC Stop Mode	$I_{\text{Stop,HSx},25}$	–	550	675	$\mu\text{A}$	<sup>3)6)</sup> SBC Stop Mode; Cyclic Sense & HSx= ON (no load); LIN, CAN, WK1..3 = OFF	P_4.4.33

**Table 4 Current Consumption (cont'd)**

 Current consumption values are specified at  $T_j = 25^\circ\text{C}$ ,  $V_S = 13.5\text{V}$ , all outputs open (unless otherwise specified)

Parameter	Symbol	Values			Unit	Note / Test Condition	Number
		Min.	Typ.	Max.			
Current consumption for HSx in SBC Stop Mode	$I_{\text{Stop,HSx,85}}$	–	575	700	$\mu\text{A}$	<sup>2)3)6)</sup> SBC Stop Mode; $T_j = 85^\circ\text{C}$ ; Cyclic Sense & HSx = ON (no load); LIN, CAN, WK1..3 = OFF	P_4.4.34
Current consumption for cyclic sense function	$I_{\text{Stop,CS25}}$	–	20	28	$\mu\text{A}$	<sup>3)7)8)</sup> SBC Stop Mode; WD = OFF	P_4.4.23
Current consumption for cyclic sense function	$I_{\text{Stop,CS85}}$	–	24	35	$\mu\text{A}$	<sup>2)3)7)8)</sup> SBC Stop Mode; $T_j = 85^\circ\text{C}$ ; WD = OFF	P_4.4.27
Current consumption for watchdog active in Stop Mode	$I_{\text{Stop,WD25}}$	–	20	28	$\mu\text{A}$	<sup>2)</sup> SBC Stop Mode; Watchdog running	P_4.4.30
Current consumption for watchdog active in Stop Mode	$I_{\text{Stop,WD85}}$	–	24	35	$\mu\text{A}$	<sup>2)</sup> SBC Stop Mode; $T_j = 85^\circ\text{C}$ ; Watchdog running	P_4.4.31
Current consumption for active fail outputs (FO1..3)	$I_{\text{Stop,FOx}}$	–	1.0	2.0	$\text{mA}$	<sup>2)</sup> all SBC Modes; $T_j = 25^\circ\text{C}$ ; FOx = ON (no load);	P_4.4.24

- 1) If the load current on VCC1 will exceed the configured VCC1 active peak threshold  $I_{\text{VCC1,peak1,r}}$  or  $I_{\text{VCC1,peak2,r}}$ , the current consumption will increase by typ. 2.9mA to ensure optimum dynamic load behavior. Same applies to VCC2. For VCC3 the current consumption will increase by typ. 1.4mA. See also [Chapter 6](#), [Chapter 7](#), [Chapter 8](#).
- 2) Not subject to production test, specified by design.
- 3) Current consumption adders of features defined for SBC Sleep Mode also apply for SBC Stop Mode and vice versa (unless otherwise specified).
- 4) No pull-up or pull-down configuration selected.
- 5) The specified WKx current consumption adder for wake capability applies regardless how many WK inputs are activated.
- 6) A typ. 75 $\mu\text{A}$  / max 125 $\mu\text{A}$  ( $T_j = 85^\circ\text{C}$ ) adder applies for every additionally activated HSx switch in SBC Stop Mode; In SBC Normal Mode every HSx switch consumes the typ. 75 $\mu\text{A}$  / max 125 $\mu\text{A}$  ( $T_j = 85^\circ\text{C}$ ) without the initial adder because the biasing is already enabled.
- 7) HS1 used for cyclic sense, Timer 2, 20ms period, 0.1ms on-time, no load on HS1.

In general the current consumption adder for cyclic sense in SBC Stop Mode can be calculated with below equation:  
 $I_{\text{Stop,CS}} = 18\mu\text{A} + (525\mu\text{A} \cdot t_{\text{ON}}/T_{\text{Per}})$

- 8) Also applies to Cyclic Wake

*Note: There is no additional current consumption contribution due to PWM generators.*

---

## System Features

# 5 System Features

This chapter describes the system features and behavior of the TLE9263BQXV33:

- State machine
- SBC mode control
- Device configuration
- State of supply and peripherals
- System functions such as cyclic sense or cyclic wake
- Supervision and diagnosis functions

The System Basis Chip (SBC) offers six operating modes:

- SBC Init Mode: Power-up of the device and after a soft reset,
- SBC Normal Mode: The main operating mode of the device,
- SBC Stop Mode: The first-level power saving mode with the main voltage regulator VCC1 enabled,
- SBC Sleep Mode: The second-level power saving mode with VCC1 disabled,
- SBC Restart Mode: An intermediate mode after a wake event from SBC Sleep or Fail-Safe Mode or after a failure (e.g. WD failure, VCC1 undervoltage reset) to bring the microcontroller into a defined state via a reset. Once the failure condition is not present anymore the device will automatically change to SBC Normal Mode after a delay time ( $t_{RD1}$ ).
- SBC Fail-Safe Mode: A safe-state mode after critical failures (e.g. WD failure, VCC1 undervoltage reset) to bring the system into a safe state and to ensure a proper restart of the system. VCC1 is disabled. It is a permanent state until either a wake event (via CAN, LINx or WKx) occurs or the overtemperature condition is not present anymore.

A special mode, called SBC Development Mode, is available during software development or debugging of the system. All above mentioned operating modes can be accessed in this mode. However, the watchdog counter is stopped and does not need to be triggered. This mode can be accessed by setting the TEST pin to GND during SBC Init Mode.

The device can be configured via hardware (external component) to determine the device behavior after a watchdog trigger failure. See [Chapter 5.1.1](#) for further information.

The System Basis Chip is controlled via a 16-bit SPI interface. A detailed description can be found in [Chapter 16](#). The configuration as well as the diagnosis is handled via the SPI. The SPI mapping of the TLE9263BQXV33 is compatible to other devices of the TLE926x and TLE927x families.

System Features

5.1 Block Description of State Machine

The different SBC Modes are selected via SPI by setting the respective SBC **MODE** bits in the register **M\_S\_CTRL**. The SBC **MODE** bits are cleared when going through SBC Restart Mode and thus always show the current SBC mode.

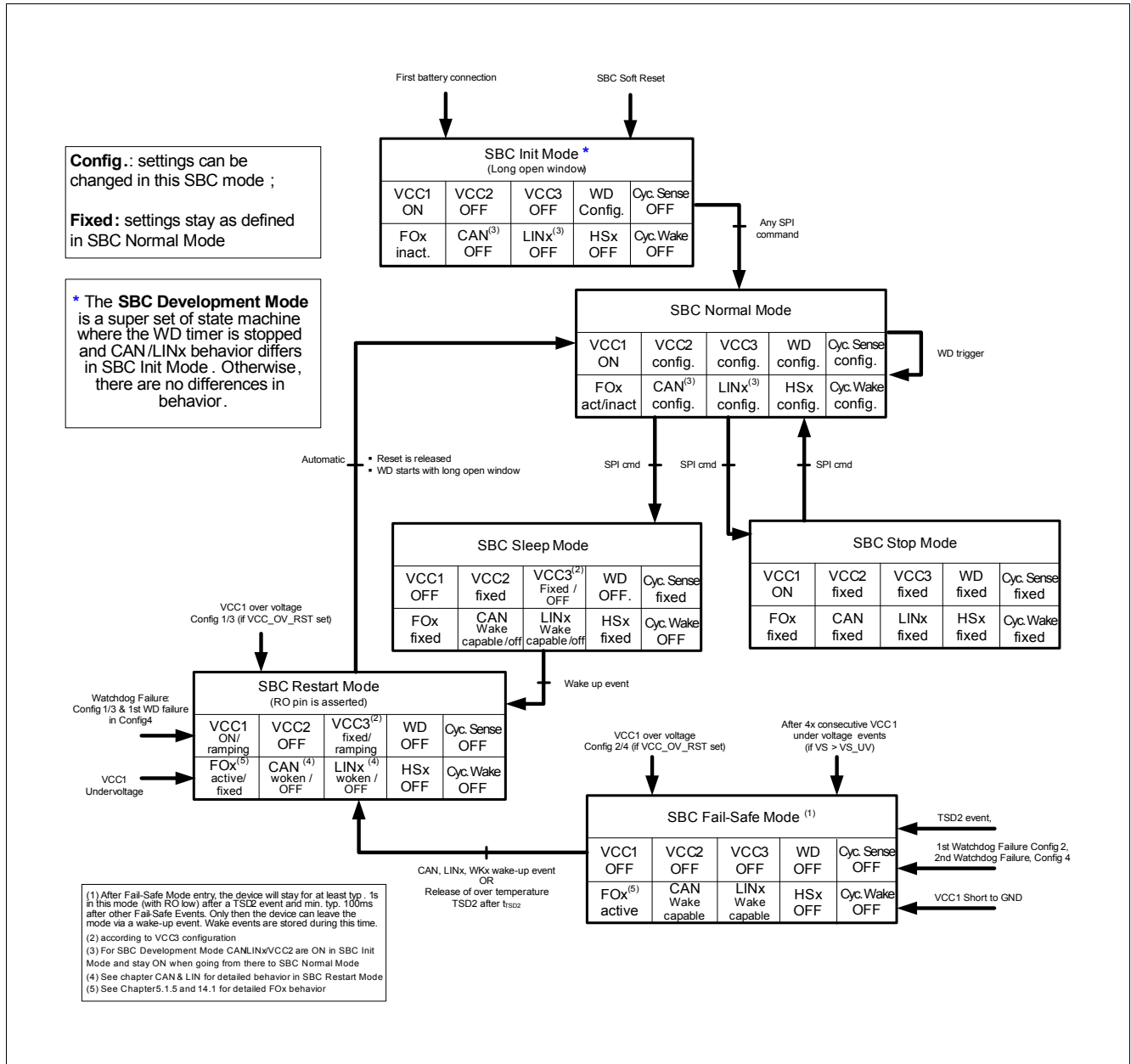


Figure 3 State Diagram showing the SBC Operating Modes

## System Features

### 5.1.1 Device Configuration and SBC Init Mode

The SBC starts up in SBC Init Mode after crossing the power-on reset  $V_{POR,r}$  threshold (see also [Chapter 15.3](#)) and the watchdog will start with a long open window ( $t_{LW}$ ).

During this power-on phase following configurations are stored in the device:

- The device behavior regarding a watchdog trigger failure and a VCC1 overvoltage condition is determined by the external circuitry on the INT pin (see below)
- The selection of the normal device operation or the SBC Development Mode (watchdog disabled for debugging purposes) will be set depending on the voltage level of the FO3/TEST pin (see also [Chapter 5.1.7](#)).

#### 5.1.1.1 Device Configuration

The configuration selection is intended to select the SBC behavior regarding a watchdog trigger failure. Depending on the requirements of the application, the VCC1 output shall be switched OFF and the device shall go to SBC Fail-Safe Mode in case of a watchdog failure (1 or 2 fails). To set this configuration (Config 2/4), the INT pin does not need an external pull-up resistor. In case VCC1 should not be switched OFF (Config 1/3), the INT pin needs to have an external pull-up resistor connected to VCC1 (see application diagram in [Chapter 17.1](#)).

[Figure 5](#) shows the timing diagram of the hardware configuration selection. The hardware configuration is defined during SBC Init Mode. The INT pin is internally pulled LOW with a weak pull-down resistor during the reset delay time  $t_{RDI}$ , i.e. after VCC1 crosses the reset threshold VRT1 and before the RO pin goes HIGH. The INT pin is monitored during this time (with a continuous filter time of  $t_{CFG_F}$ ) and the configuration (depending on the voltage level at INT) is stored at the rising edge of RO.

*Note: If the **POR** bit is not cleared then the internal pull-down resistor will be reactivated every time RO is pulled LOW the configuration will be updated at the rising edge of RO. Therefore it is recommended to clear the **POR** bit right after initialization. In case there is no stable signal at INT, then the default value '0' will be taken as the config select value = SBC Fail-Safe Mode.*

System Features

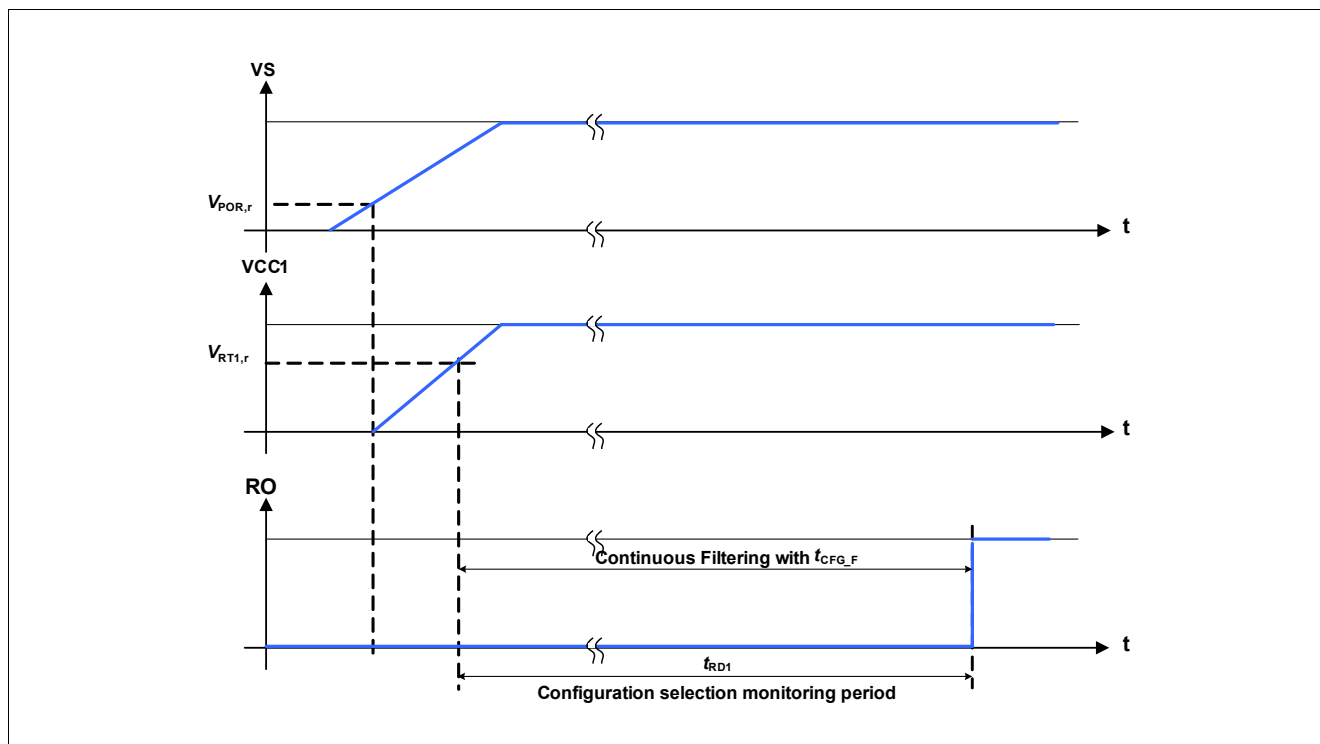


Figure 4 Hardware Configuration Selection Timing Diagram

There are four different device configurations ([Table 5](#)) available defining the watchdog failure and the VCC1 overvoltage behavior. The configurations can be selected via the external connection on the INT pin and the SPI bit **CFG** in the **HW\_CTRL** register (see also [Chapter 16.4](#)):

- **CFG** = '1': Config 1 and Config 3:
  - A watchdog trigger failure leads to SBC Restart Mode and depending on **CFG** the Fail Outputs (FOx) are activated after the 1st (Config 1) or 2nd (Config 3) watchdog trigger failure;
  - A VCC1 overvoltage detection will lead to SBC Restart Mode if **VCC1\_OV\_RST** is set. **VCC1\_OV** will be set and the Fail Outputs are activated;
- **CFG** = '0': Config 2 and Config 4:
  - A watchdog trigger failure leads to SBC Fail-Safe Mode and depending on **CFG** the Fail Outputs (FOx) are activated after the 1st (Config 2) or 2nd (Config 4) watchdog trigger failure. The first watchdog trigger failure in Config 4 will lead to SBC Restart Mode;
  - A VCC1 overvoltage detection will lead to SBC Fail-Safe Mode if **VCC1\_OV\_RST** is set. **VCC1\_OV** will be set and the Fail Outputs are activated;

The respective device configuration can be identified by reading the SPI bit **CFG** in the **HW\_CTRL** register and the **CFG** bit in the **WK\_LVL\_STAT** register.

[Table 5](#) shows the configurations and the device behavior in case of a watchdog trigger failure:

Table 5 Watchdog Trigger Failure Configuration

Config	INT Pin ( <b>CFG</b> )	SPI Bit <b>CFG</b>	Event	FOx Activation	SBC Mode Entry
1	External pull-up	1	1 x Watchdog Failure	after 1st WD Failure	SBC Restart Mode
2	No ext. pull-up	1	1 x Watchdog Failure	after 1st WD Failure	SBC Fail-Safe Mode
3	External pull-up	0	2 x Watchdog Failure	after 2nd WD Failure	SBC Restart Mode
4	No ext. pull-up	0	2 x Watchdog Failure	after 2nd WD Failure	SBC Fail-Safe Mode



## System Features

**Table 6** shows the configurations and the device behavior in case of a VCC1 overvoltage detection when **VCC1\_OV\_RST** is set:

**Table 6 Device Behavior in Case of VCC1 Overvoltage Detection**

Config	INT Pin (CFGF)	CFG Bit	VCC1_OV_RST	Event	VCC1_OV	FOx Activation	SBC Mode Entry
1-4	any value	x	0	1 x VCC1 OV	1	no FOx activation	unchanged
1	External pull-up	1	1	1 x VCC1 OV	1	after 1st VCC1 OV	SBC Restart Mode
2	No ext. pull-up	1	1	1 x VCC1 OV	1	after 1st VCC1 OV	SBC Fail-Safe Mode
3	External pull-up	0	1	1 x VCC1 OV	1	after 1st VCC1 OV	SBC Restart Mode
4	No ext. pull-up	0	1	1 x VCC1 OV	1	after 1st VCC1 OV	SBC Fail-Safe Mode

The respective configuration will be stored for all conditions and can only be changed by powering down the device ( $V_S < V_{POR,f}$ ).

---

## System Features

### 5.1.1.2 SBC Init Mode

In SBC Init Mode, the device waits for the microcontroller to finish its startup and initialization sequence. In the SBC Init Mode any valid SPI command will bring the SBC to SBC Normal Mode. During the long open window the watchdog has to be triggered. Thereby the watchdog will be automatically configured.

A missing watchdog trigger during the long open window will cause a watchdog failure and the device will enter SBC Restart Mode.

Wake events are ignored during SBC Init Mode and will therefore be lost.

*Note:* Any SPI command will bring the SBC to SBC Normal Mode even if it is a illegal SPI command (see [Chapter 16.2](#)).

*Note:* For a safe start-up, it is recommended to use the first SPI command to trigger and to configure the watchdog (see [Chapter 15.2](#)).

*Note:* At power up no **VCC1\_UV** will be issued nor will FOx be triggered as long as VCC1 is below the  $V_{RT,x}$  threshold and if VS is below the VCC1 short circuit detection threshold  $V_{s,uv}$ . The RO pin will be kept low as long as VCC1 is below the selected  $V_{RT,x}$  threshold.

---

## System Features

### 5.1.2 SBC Normal Mode

The SBC Normal Mode is the standard operating mode for the SBC. All configurations have to be done in SBC Normal Mode before entering a low-power mode (see also [Chapter 5.1.6](#) for the device configuration defining the Fail-Safe Mode behavior). A wake-up event on CAN, LINx and WKx will create an interrupt on pin INT - however, no change of the SBC mode will occur. The configuration options are listed below:

- VCC1 is active
- VCC2 can be switched ON or OFF (default = OFF)
- VCC3 is configurable (OFF coming from SBC Init Mode; as previously programmed coming from SBC Restart Mode)
- CAN is configurable (OFF coming from SBC Init Mode; OFF or wake capable coming from SBC Restart Mode, see also [Chapter 5.1.5](#))
- LIN is configurable (OFF coming from SBC Init Mode; OFF or wake capable coming from SBC Restart Mode, see also [Chapter 5.1.5](#))
- HS Outputs can be switched ON or OFF (default = OFF) or can be controlled by PWM; HS Outputs are OFF coming from SBC Restart Mode
- Wake pins show the input level and can be selected to be wake capable (interrupt)
- Cyclic sense can be configured with HS1...4 and Timer1 or Timer 2
- Cyclic wake can be configured with Timer1 or Timer2
- Watchdog is configurable
- All FOx outputs are OFF by default. Coming from SBC Restart Mode FOx can be active (due to a failure event, e.g. watchdog trigger failure, VCC1 short circuit, etc.) or inactive (no failure occurred)

In SBC Normal Mode, there is the possibility of testing the FO outputs, i.e. to verify if setting the FO pin to low will create the intended behavior within the system. The FO output can be enabled and then disabled again by the microcontroller by setting the **FO\_ON** SPI bit. This feature is only intended for testing purposes.

## System Features

### 5.1.3 SBC Stop Mode

The SBC Stop Mode is the first level technique to reduce the overall current consumption by setting the voltage regulators VCC1, VCC2 and VCC3 into a low-power mode. In this mode VCC1 is still active and supplying the microcontroller, which can enter a power down mode. The VCC2 supply, CAN & LIN mode as well as the HSx outputs can be configured to stay enabled. All kind of settings have to be done before entering SBC Stop Mode. In SBC Stop Mode any kind of SPI WRITE commands are ignored and the **SPI\_FAIL** bit is set, except for changing to SBC Normal Mode, triggering a SBC Soft Reset, refreshing the watchdog as well as for reading and clearing the SPI status registers. A wake-up event on CAN, LINx and WKx will create an interrupt on pin INT - however, no change of the SBC mode will occur. The configuration options are listed below:

- VCC1 is ON
- VCC2 is fixed as configured in SBC Normal Mode
- VCC3 is fixed as configured in SBC Normal Mode
- CAN mode is fixed as configured in SBC Normal Mode
- LIN mode is fixed as configured in SBC Normal Mode
- WK pins are fixed as configured in SBC Normal Mode
- HS Outputs are fixed as configured in SBC Normal Mode
- Cyclic sense is fixed as configured in SBC Normal Mode
- Cyclic wake is fixed as configured in SBC Normal Mode
- Watchdog is fixed as configured in SBC Normal Mode
- SBC Soft Reset can be triggered
- FOx outputs are fixed, i.e. the state from SBC Normal Mode is maintained

An interrupt is triggered on the pin INT when SBC Stop Mode is entered and not all wake source signalization flags from **WK\_STAT\_1** and **WK\_STAT\_2** were cleared.

*Note: If switches are enabled during SBC Stop Mode, e.g. HSx on with or without PWM, then the SBC current consumption will increase (see [Chapter 4.4](#)).*

*Note: It is not possible to switch directly from SBC Stop Mode to SBC Sleep Mode. Doing so will also set the **SPI\_FAIL** flag and will bring the SBC into Restart Mode.*

*Note: When WK1 and WK2 are configured for the alternate measurement function (**WK\_MEAS** = 1) then the wake inputs cannot be selected as wake input sources.*

## System Features

### 5.1.4 SBC Sleep Mode

The SBC Sleep Mode is the second level technique to reduce the overall current consumption to a minimum needed to react on wake-up events or for the SBC to perform autonomous actions (e.g. cyclic sense). In this mode, VCC1 is OFF and not supplying the microcontroller anymore. The VCC2 supply as well as the HSx outputs can be configured to stay enabled. The settings have to be done before entering SBC Sleep Mode. A wake-up event on CAN, LINx or WKx will bring the device via SBC Restart Mode into SBC Normal Mode again and signal the wake source. The configuration options are listed below:

- VCC1 is OFF
- VCC2 is fixed as configured in SBC Normal Mode
- VCC3 is fixed or OFF as configured in SBC Normal Mode
- CAN mode changes automatically from ON or Receive Only Mode to wake capable mode or can be selected to be OFF
- LIN mode changes automatically from ON or Receive Only Mode to wake capable mode or can be selected to be OFF
- WK pins are fixed as configured in SBC Normal Mode
- HS Outputs are fixed as configured in SBC Normal Mode
- Cyclic sense is fixed as configured in SBC Normal Mode
- Cyclic wake is not available
- Watchdog is OFF
- FOx outputs are fixed, i.e. the state from SBC Normal Mode is maintained
- As VCC1 is OFF during SBC Sleep Mode, no SPI communication is possible;
- The Sleep Mode entry is signalled in the SPI register **DEV\_STAT** with the bit **DEV\_STAT**

It is not possible to switch all wake sources off in SBC Sleep Mode. Doing so will set the **SPI\_FAIL** flag and will bring the SBC into SBC Restart Mode.

In order to enter SBC Sleep Mode successfully, all wake source signalization flags from **WK\_STAT\_1** and **WK\_STAT\_2** need to be cleared. A failure to do so will result in an immediate wake-up from SBC Sleep Mode by going via SBC Restart to Normal Mode.

All settings must be done before entering SBC Sleep Mode.

*Note: If switches are enabled during SBC Sleep mode, e.g. HSx on with or without PWM, then the SBC current consumption will increase (see **Chapter 4.4**).*

*Note: Cyclic Sense function will not work properly anymore in case of an overcurrent, overtemperature, under- or overvoltage (in case function is selected) event because the respective HS switch will be disabled.*

*Note: When WK1 and WK2 are configured for the alternate measurement function (**WK\_MEAS** = 1) then the wake inputs cannot be selected as wake input sources.*

## System Features

### 5.1.5 SBC Restart Mode

There are multiple reasons to enter the SBC Restart Mode. The purpose of the SBC Restart Mode is to reset the microcontroller:

- in case of undervoltage on VCC1 in SBC Normal and in SBC Stop Mode,
- in case of overvoltage on VCC1 if the bit **VCC1\_OV\_RST** is set and if **CFGP** = '1',
- due to 1st incorrect Watchdog triggering (only if Config1, Config3 or Config 4 is selected, otherwise SBC Fail-Safe Mode is immediately entered),
- In case of a wake event from SBC Sleep or SBC Fail-Safe Mode or a release of overtemperature shutdown (TSD2) out of SBC Fail-Safe Mode this transition is used to ramp up VCC1 after a wake in a defined way.

From SBC Restart Mode, the SBC goes automatically to SBC Normal Mode, i.e. the mode is left automatically by the SBC without any microcontroller influence. The SBC **MODE** bits are cleared. As shown in **Figure 47** the Reset Output (RO) is pulled low when entering Restart Mode and is released at the transition to Normal Mode after the reset delay time ( $t_{RD1}$ ). The watchdog timer will start with a long open window starting from the moment of the rising edge of RO and the watchdog period setting in the register **WD\_CTRL** will be changed to the respective default value '100'.

Leaving the SBC Restart Mode will not result in changing / deactivating the Fail outputs.

The behavior of the blocks is listed below:

- All FOx outputs are activated in case of a 1st watchdog trigger failure (if Config1 or Config2 is selected) or in case of VCC1 overvoltage detection (if **VCC1\_OV\_RST** is set)
- VCC1 is ON or ramping up
- VCC2 will be disabled if it was activated before
- VCC3 is fixed or ramping as configured in SBC Normal Mode
- CAN is "woken" due to a wake event or OFF depending on previous SBC and transceiver mode (see also **Chapter 10**). It is wake capable when it was in CAN Normal-, Receive Only or wake capable mode before SBC Restart Mode
- LIN is "woken" or OFF depending on previous SBC and transceiver mode (see also **Chapter 11**). It is wake capable when it was in LIN Normal-, Receive Only or wake capable mode before SBC Restart Mode.
- HS Outputs will be disabled if they were activated before
- RO is pulled low during SBC Restart Mode
- SPI communication is ignored by the SBC, i.e. it is not interpreted
- The Restart Mode entry is signalled in the SPI register **DEV\_STAT** with the bits **DEV\_STAT**

**Table 7 Reasons for Restart - State of SPI Status Bits after Return to Normal Mode**

Prev. SBC Mode	Event	DEV_STAT	WD_FAIL	VCC1_UV	VCC1_OV	VCC1_SC
Normal	1x Watchdog Failure	01	01	x	x	x
Normal	2x Watchdog Failure	01	10	x	x	x
Normal	VCC1 undervoltage reset	01	xx	1	x	x
Normal	VCC1 overvoltage reset	01	xx	x	1	x
Stop	1x Watchdog Failure	01	01	x	x	x
Stop	2x Watchdog Failure	01	10	x	x	x
Stop	VCC1 undervoltage reset	01	xx	1	x	x
Stop	VCC1 overvoltage reset	01	xx	x	1	x
Sleep	Wake-up event	10	xx	x	x	x
Fail-Safe	Wake-up event	01	see "Reasons for Fail Safe, <b>Table 8</b> "			

## System Features

Note: An overvoltage event on VCC1 will only lead to SBC Restart Mode if the bit `VCC1_OV_RST` is set and if `CFGP` = '1' (Config 1/3).

Note: The content of the `WD_FAIL` bits will depend on the device configuration, e.g. 1 or 2 watchdog failures.

### 5.1.6 SBC Fail-Safe Mode

The purpose of this mode is to bring the system in a safe status after a failure condition by turning off the VCC1 supply and powering off the microcontroller. After a wake event the system is then able to restart again.

The Fail-Safe Mode is automatically reached for following events:

- after an SBC thermal shutdown (TSD2) (see also [Chapter 15.9.3](#)),
- in case of overvoltage on VCC1 if the bit `VCC1_OV_RST` is set and if `CFGP` = '0',
- after a 1st incorrect watchdog trigger in Config2 (`CFG` = 1) and after a 2nd incorrect watchdog trigger in Config4 (`CFG` = 0) (see also [Chapter 5.1.1](#)),
- if VCC1 is shorted to GND (see also [Chapter 15.7](#)),
- After 4 consecutive VCC1 undervoltage events (only if  $V_S > V_{S,UV}$ , see [Chapter 15.6](#)).

In this case, the default wake sources (CAN, LINx, WK1...3, see also registers `WK_CTRL_2`, `BUS_CTRL_1` and `BUS_CTRL_2`) are activated, the wake events are cleared in the register `WK_STAT_1`, and all output drivers and all voltage regulators are switched off. When WK1 and WK2 are configured for the alternate measurement function (`WK_MEAS` = 1) then WK1 and WK2 will stay configured for the measurement function when SBC Fail-Safe Mode is entered, i.e. they will not be activated as wake sources.

The SBC Fail-Safe Mode will be maintained until a wake event on the default wake sources occurs. To avoid any fast toggling behavior a filter time of typ. 100ms ( $t_{FS,min}$ ) is implemented. Wake events during this time will be stored and will automatically lead to entering SBC Restart Mode after the filter time.

In case of an VCC1 overtemperature shutdown (TSD2) the SBC Restart Mode will be reached automatically after a filter time of typ. 1s ( $t_{TSD2}$ ) without the need of a wake event.

Leaving the SBC Fail-Safe Mode will not result in deactivation of the Fail Output pins.

The following functions are influenced during SBC Fail-Safe Mode:

- All FOx outputs are activated (see also [Chapter 14](#))
- VCC1 is OFF
- VCC2 is OFF
- VCC3 is OFF
- CAN is wake capable
- LINx is wake capable
- HS Outputs are OFF
- WK pins are wake capable through static sense (with default 16µs filter time)
- Cyclic sense and Cyclic wake is disabled
- SPI communication is disabled because VCC1 is OFF
- The Fail-Safe Mode activation is signalled in the SPI register `DEV_STAT` with the bits `FAILURE` and `DEV_STAT`

## System Features

**Table 8 Reasons for Fail-Safe - State of SPI Status Bits after Return to Normal Mode**

Prev. SBC Mode	Failure Event	DEV_STAT	TSD2	WD_FAIL	VCC1_UV	VCC1_UV_FS	VCC1_OV	VCC1_SC
Normal	1 x Watchdog Failure	01	x	01	x	x	x	x
Normal	2 x Watchdog Failure	01	x	10	x	x	x	x
Normal	TSD2	01	1	xx	x	x	x	x
Normal	VCC1 short to GND	01	x	xx	1	x	x	1
Normal	4x VCC1 UV	01	x	xx	1	1	x	x
Normal	VCC1 overvoltage	01	x	xx	x	x	1	x
Stop	1 x Watchdog Failure	01	x	01	x	x	x	x
Stop	2 x Watchdog Failure	01	x	10	x	x	x	x
Stop	TSD2	01	1	xx	x	x	x	x
Stop	VCC1 short to GND	01	x	xx	1	x	x	1
Stop	4x VCC1 UV	01	x	xx	1	1	x	x
Stop	VCC1 overvoltage	01	x	xx	x	x	1	x

Note: An overvoltage event on VCC1 will only lead to SBC Fail-Safe Mode if the bit VCC1\_OV\_RST is set and if **CFGF** = '0' (Config 2/4).

Note: The content of the WD\_FAIL bits will depend on the device configuration, e.g. 1 or 2 watchdog failures.

Note: See [Chapter 15.6.1](#) for detailed description of the 4x VCC1 undervoltage behavior.

### 5.1.7 SBC Development Mode

The SBC Development Mode is used during the development phase of the module. It is especially useful for software development.

Compared to the default SBC user mode operation, this mode is a super set of the state machine. The device will start also in SBC Init Mode and it is possible to use all the SBC Modes and functions with following differences:

- Watchdog is stopped and does not need to be triggered. Therefore no reset is triggered due to watchdog failure
- SBC Fail-Safe and SBC Restart Mode are not reached due to watchdog failure but the other reasons to enter these modes are still valid
- LINx, CAN and VCC2 default value in SBC INIT MODE and entering SBC Normal Mode from SBC Init Mode is ON instead of OFF

The SBC Development Mode is reached automatically if the FO3/TEST pin is set and kept LOW during SBC Init Mode. The voltage level monitoring is started as soon as  $VS > V_{POR,f}$ . The Development Mode is configured and maintained if SBC Init Mode is left by sending any SPI command while FO3/TEST is LOW. In case the FO3/TEST level will be HIGH for longer than  $t_{TEST}$  during the monitoring period then the SBC Development Mode is not reached.

The SBC will remain in this mode for all conditions and can only be left by powering down the device ( $VS < V_{POR,f}$ ).



---

## System Features

*Note:* The absolute maximum ratings of the pin FO3/TEST must be observed. To increase the robustness of this pin during debugging or programming a series resistor between FO3/TEST and the connector can be added (see [Figure 61](#)).

## System Features

### 5.2 Wake Features

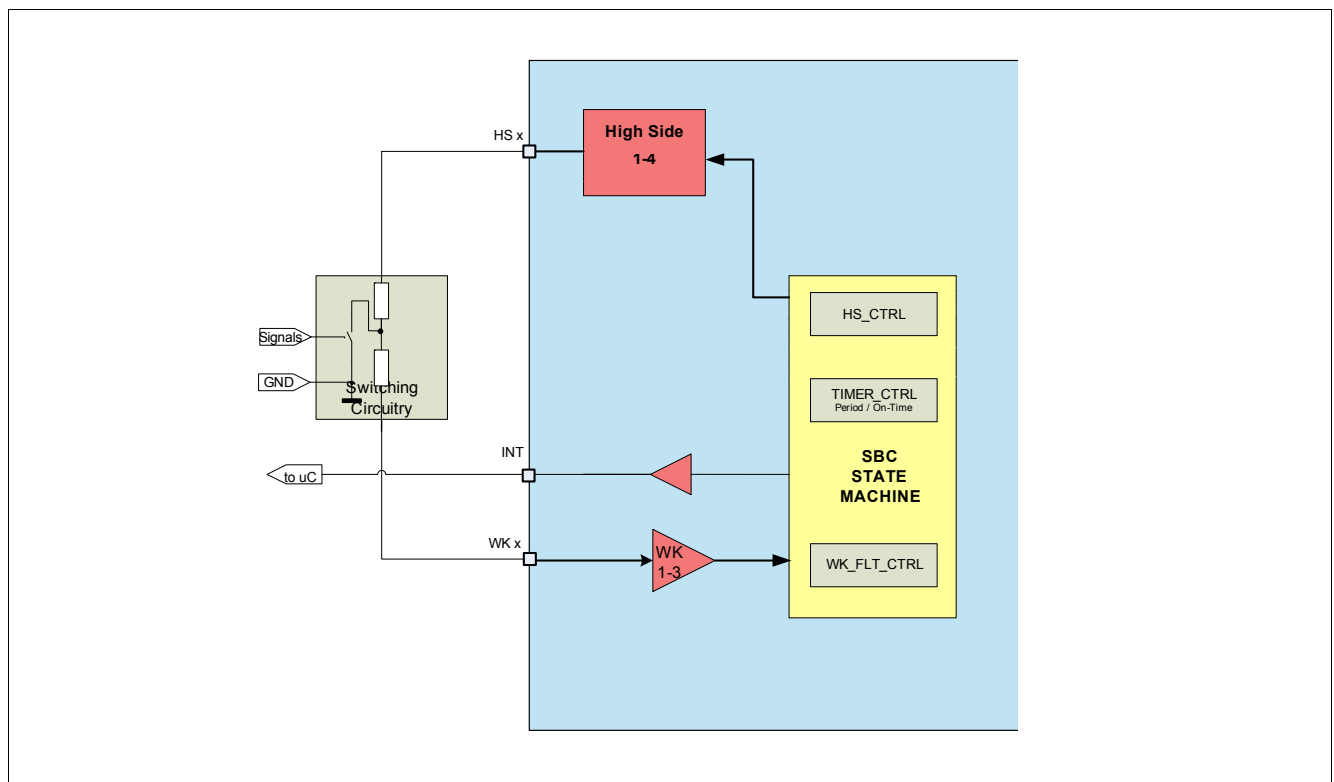
Following wake sources are implemented in the device:

- Static Sense: WK inputs are permanently active (see [Chapter 12](#))
- Cyclic Sense: WK inputs only active during on-time of cyclic sense period (see below)
- Cyclic Wake: internal wake source controlled via internal timer (see below)
- CAN wake: Wake-up via CAN message (see [Chapter 10](#))
- LIN wake: Wake-up via LIN message (see [Chapter 11](#))

#### 5.2.1 Cyclic Sense

The cyclic sense feature is intended to reduce the quiescent current of the device and the application.

In the cyclic sense configuration, one or more high-side drivers are switched on periodically controlled by [TIMER1\\_CTRL](#) and [TIMER2\\_CTRL](#). The respective high-side drivers supply external circuitries e.g. switches and/or resistor arrays, which are connected to one or more wake inputs (see [Figure 5](#)). Any edge change of the WK<sub>x</sub> input signal during the on-time of the cyclic sense period causes a wake. Depending on the SBC mode, either the INT is pulled low (SBC Normal Mode and Stop Mode) or the SBC is woken enabling the VCC1 (after SBC Sleep and SBC Fail-Safe Mode).



**Figure 5** Cyclic Sense Working Principle

System Features

5.2.1.1 Configuration and Operation of Cyclic Sense

The correct sequence to configure the cyclic sense is shown in **Figure 6**. All the configurations have to be performed before the on-time is set in the **TIMERx\_CTRL** registers. The settings “OFF / LOW” and “OFF / HIGH” define the voltage level of the respective HS driver before the start of the cyclic sense. The intention of this selection is to avoid an unintentional wake due to a voltage level change at the start of the cyclic sense.

Cyclic Sense (=TimerX) will start as soon as the respective on-time has been selected independently from the assignment of the HS and filter configuration. The selection of the respective timer (Config C/D see **Chapter 12.2.1**) must therefore be done before starting the timer. The correct configuration sequence is as follows:

- Configure the initial level
- Mapping of a Timer to the respective HSx outputs
- Configuring the respective filter timing and WK pins
- Configuring the timer period and on-time

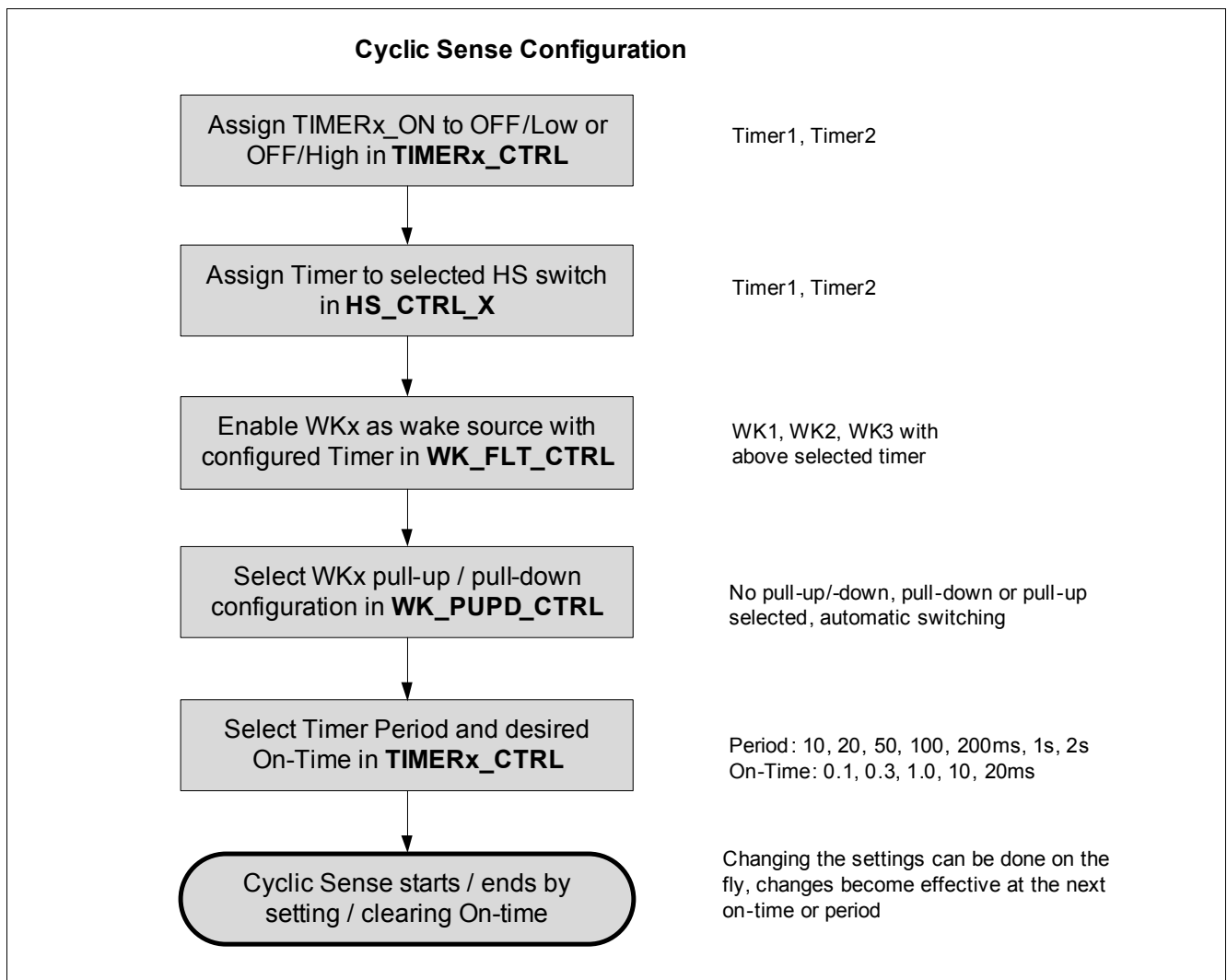


Figure 6 Cyclic Sense: Configuration and Sequence

Note: All configurations of period and on-time can be selected. However, recommended on-times for cyclic sense are 0.1ms, 0.3ms and 1ms. The SPI\_FAIL will be set if the on-time is longer than the period.

---

## System Features

The first sample of the WK input value (HIGH or LOW) is taken as the reference for the next cycle. A change of the WK input value between the first and second cycle recognized during the on-time of the second cycle will cause a wake from SBC Sleep Mode or an interrupt during SBC Normal or SBC Stop Mode.

A filter time of 16 $\mu$ s is implemented to avoid a parasitic wake-up due to transients or EMC disturbances. The filter time  $t_{FWK1}$  is triggered right at the end of the selected on-time and a wake signal is recognized if:

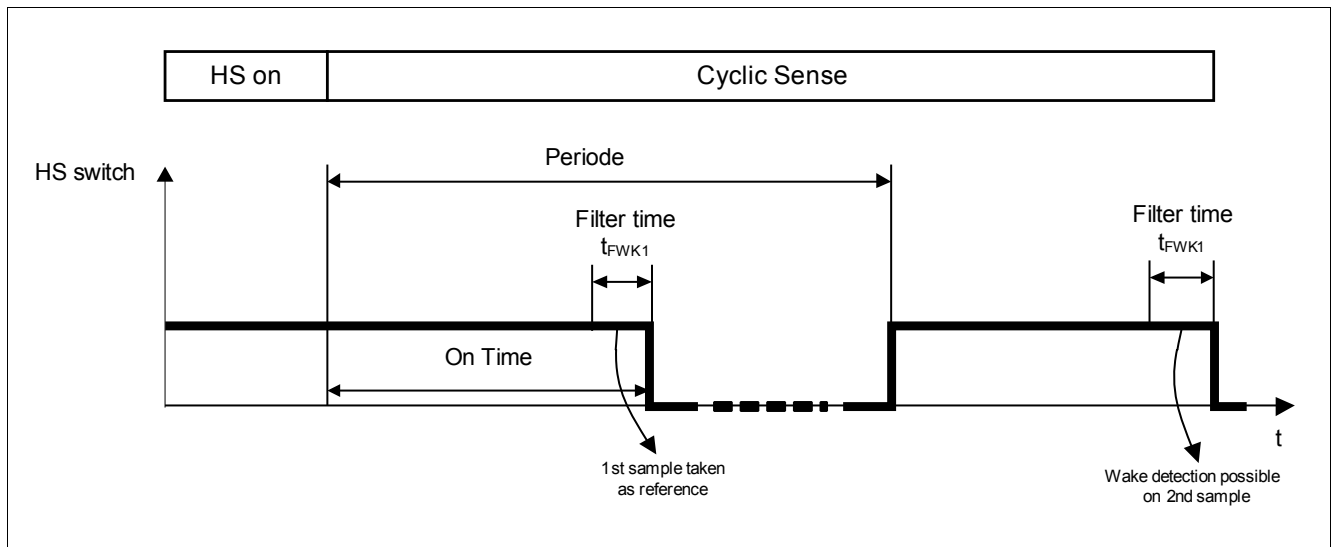
- the input level will not cross the switching threshold level of typ. 3V during the selected filter time (i.e. if the signal will keep the HIGH or LOW level) and
- there was an input level change between the current and previous cycle

**System Features**

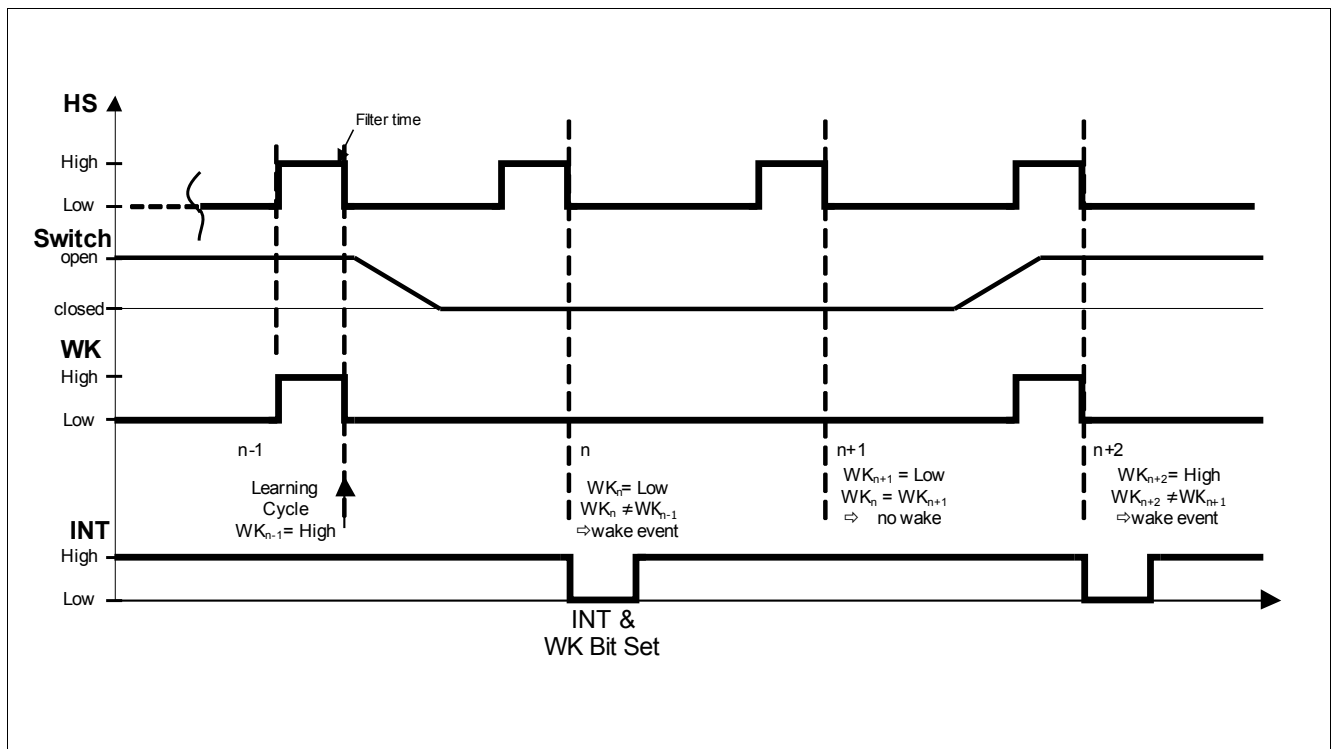
A wake event due to cyclic sense will set the respective bit WK1\_WU, WK2\_WU, or WK3\_WU.

During Cyclic Sense, WK\_LVL\_STAT is updated only with the sampled voltage levels of the WKx pins in SBC Normal or SBC Stop Mode.

The functionality of the sampling and different scenarios are depicted in Figure 7 to Figure 9. The behavior in SBC Stop and SBC Sleep Mode is identical except that in Stop Mode INT will be triggered to signal a change of WK input levels and in SBC Sleep Mode, VCC1 will power-up instead.

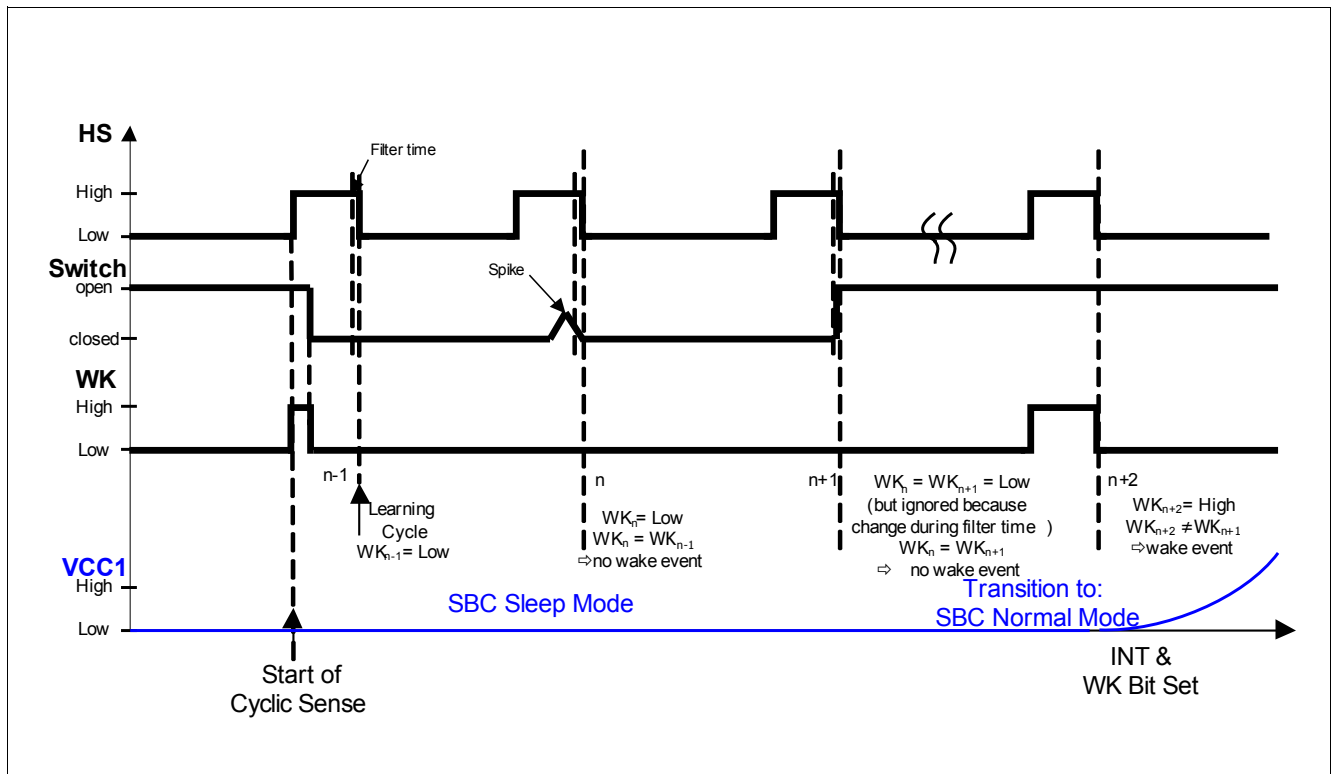


**Figure 7** Wake Input Timing



**Figure 8** Cyclic Sense Example in SBC Stop Mode, HSx starts “OFF”/LOW, GND based WKx input

System Features



**Figure 9** Cyclic Sense Example in SBC Sleep Mode, HSx starts “OFF”/HIGH, GND based WKx input

The cyclic sense function will not work properly anymore in case of following conditions:

- in case SBC Fail-Safe Mode is entered: The respective HS Switch will be disabled and the respective wake pin will be changed to static sensing
- In SBC Normal, Stop, or Sleep Mode in case of an overcurrent, overtemperature, under- or overvoltage (in case function is selected) event: the respective HS switch will be disabled

*Note: The internal timers for cyclic sense are not disabled automatically in case the HS switch is turned off due to above mentioned failures. This must be considered to avoid loss of wake events.*

**5.2.1.2 Cyclic Sense in Low Power Mode**

If cyclic sense is intended for SBC Stop or SBC Sleep Mode mode, it is necessary to activate the cyclic sense in SBC Normal Mode before going to the low power mode. A wake event due to cyclic sense will set the respective bit WK1\_WU, WK2\_WU or WK3\_WU. In Stop Mode the wake event will trigger an interrupt, in Sleep Mode the wake event will send the device via Restart Mode to Normal Mode. Before returning to SBC Sleep mode, the wake status register **WK\_STAT\_1** and **WK\_STAT\_2** needs to be cleared. Trying to go to SBC Sleep mode with uncleared wake flags, such as WKx\_WU the SBC will directly wake-up from Sleep Mode by going via Restart Mode to Normal Mode, a reset is issued. The WKx\_WU bit is seen as source for the wake. This is implemented in order not to loose an wake event during the transition.

## System Features

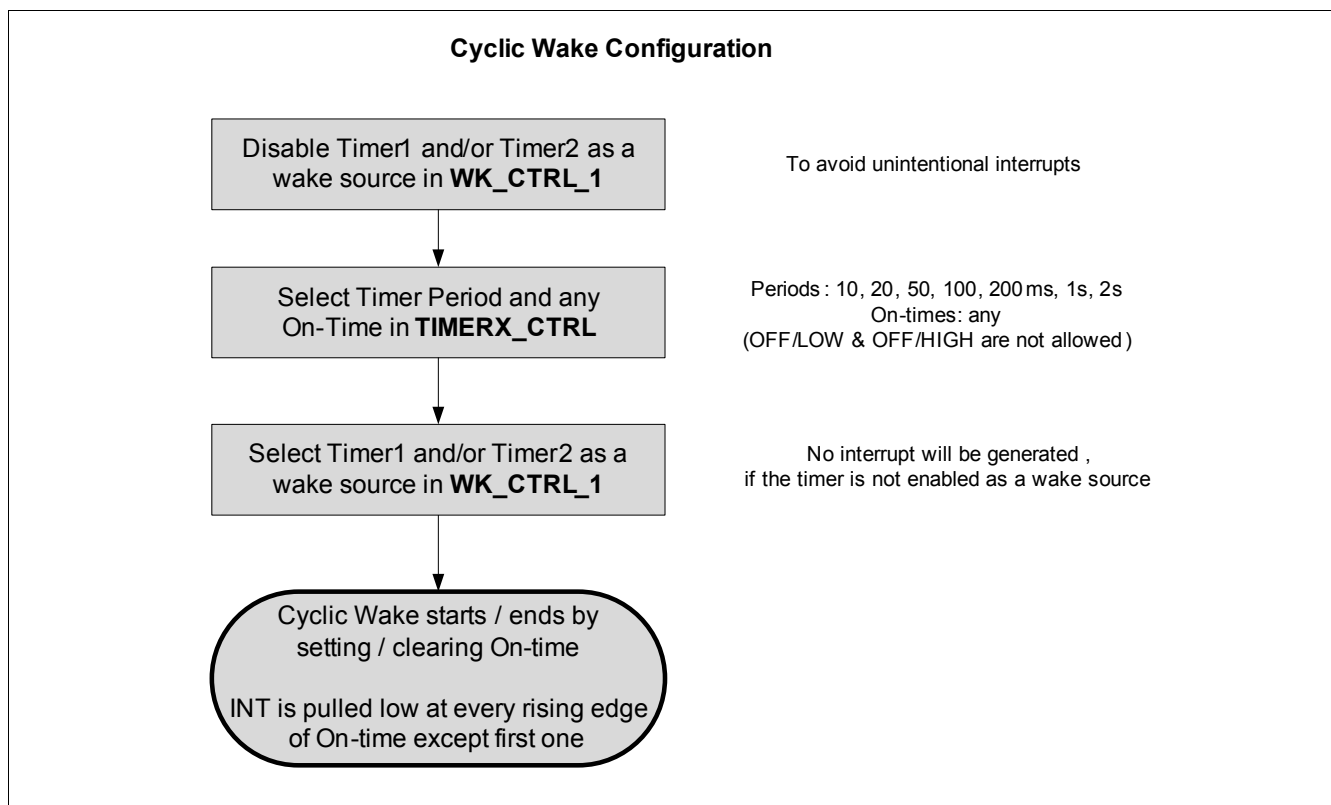
### 5.2.2 Cyclic Wake

The cyclic wake feature is intended to reduce the quiescent current of the device and application.

For the cyclic wake feature one or both timers are configured as internal wake-up source and will periodically trigger an interrupt in SBC Normal and SBC Stop Mode.

The correct sequence to configure the cyclic wake is shown in **Figure 10**. The sequence is as follows:

- First, disable the timers to ensure that there is not unintentional interrupt when activating cyclic wake,
- Enable Timer1 and/or Timer2 as a wake-up source in the register **WK\_CTRL\_1**,
- Configure the respective period Timer1 and/or Timer2. Also an on-time (any value) must be selected to start the cyclic wake even if the value is ignored.



**Figure 10 Cyclic Wake: Configuration and Sequence**

As in cyclic sense, the cyclic wake function will start as soon as the on-time is configured. An interrupt is generated for every start of the on time except for the very first time when the timer is started

---

## System Features

### 5.2.3 Internal Timer

The integrated Timer1 and Timer2 are typically used to wake up the microcontroller periodically (cyclic wake) or to perform cyclic sense on the wake inputs. Therefore, the timers can be mapped to the dedicated HS switches by SPI (via [HS\\_CTRL1...2](#)).

Following periods and on-times can be selected via the register [TIMER1\\_CTRL](#) and [TIMER2\\_CTRL](#) respectively:

- Period: 10ms / 20ms / 50ms / 100ms / 200ms / 1s / 2s
- On time: 0.1ms / 0.3ms / 1.0ms / 10ms / 20ms / OFF at HIGH or LOW

### 5.3 Supervision Features

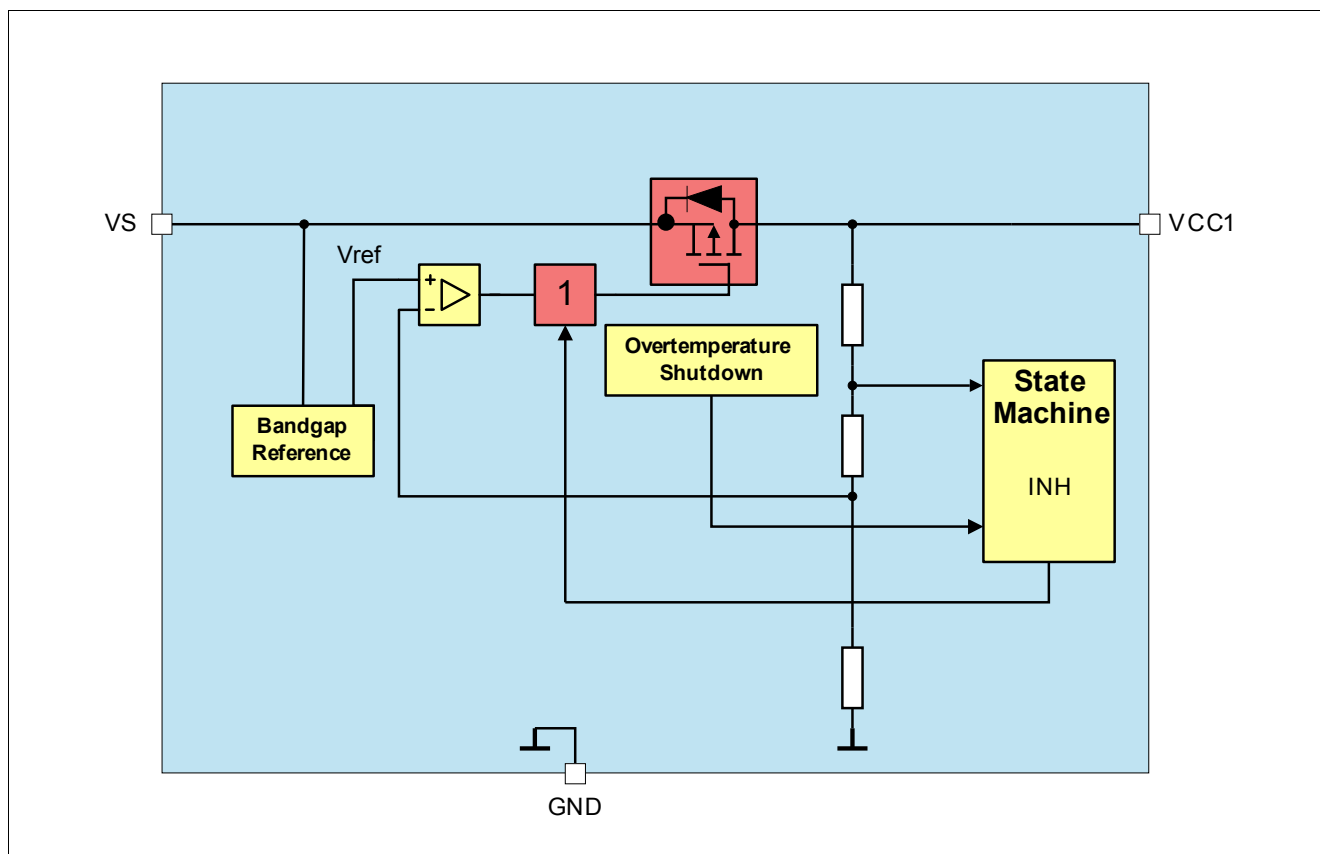
The device offers various supervision features to support functional safety requirements. Please see [Chapter 15](#) for more information.



## Voltage Regulator 1

## 6 Voltage Regulator 1

### 6.1 Block Description



**Figure 11** Module Block Diagram

#### Functional Features

- 3.3V low-drop voltage regulator
- Undervoltage monitoring with adjustable reset level, VCC1 prewarning and VCC1 short circuit detection ( $V_{RT1/2/3/4}$ ,  $V_{PW,f}$ ). Please refer to [Chapter 15.6](#) and [Chapter 15.7](#) for more information.
- Short circuit detection and switch off with undervoltage fail threshold, device enters SBC Fail-Safe Mode
- $\geq 470\text{nF}$  ceramic capacitor at voltage output for stability, with  $\text{ESR} < 1\Omega @ f = 10\text{ kHz}$ , to achieve the voltage regulator control loop stability based on the safe phase margin (bode diagram).
- Output current capability up to  $I_{VCC1,lim}$ .

## Voltage Regulator 1

### 6.2 Functional Description

The Voltage Regulator 1 (=VCC1) is “ON” in SBC Normal and SBC Stop Mode and is disabled in SBC Sleep and in SBC Fail-Safe Mode. The regulator can provide an output current up to  $I_{VCC1,lim}$ .

For low-quiescent current reasons, the output voltage tolerance is decreased in SBC Stop Mode because only a low-power mode regulator with a lower accuracy ( $V_{CC1,out41}$ ) will be active for small loads. If the load current on VCC1 exceeds the selected threshold ( $I_{VCC1,peak1,r}$  or  $I_{VCC1,peak2,r}$ ) then the high-power mode regulator will be also activated to support an optimum dynamic load behavior. The current consumption will then increase by typ. 2.9mA.

If the load current on VCC1 falls below the selected threshold ( $I_{VCC1,peak1,f}$  or  $I_{VCC1,peak2,f}$ ), then the low-quiescent current mode is resumed again by disabling the high-power mode regulator.

Both regulators (low-power mode and high-power mode) are active in SBC Normal Mode.

Two different active peak thresholds can be selected via SPI:

- **I\_PEAK\_TH** = ‘0’ (default): the lower VCC1 active peak threshold 1 is selected with lowest quiescent current consumption in SBC Stop Mode (**I<sub>Stop\_1,25</sub>**, **I<sub>Stop\_1,85</sub>**);
- **I\_PEAK\_TH** = ‘1’: the higher VCC1 active peak threshold 2 is selected with an increased quiescent current consumption in SBC Stop Mode (**I<sub>Stop\_2,25</sub>**, **I<sub>Stop\_2,85</sub>**);

## Voltage Regulator 1

## 6.3 Electrical Characteristics

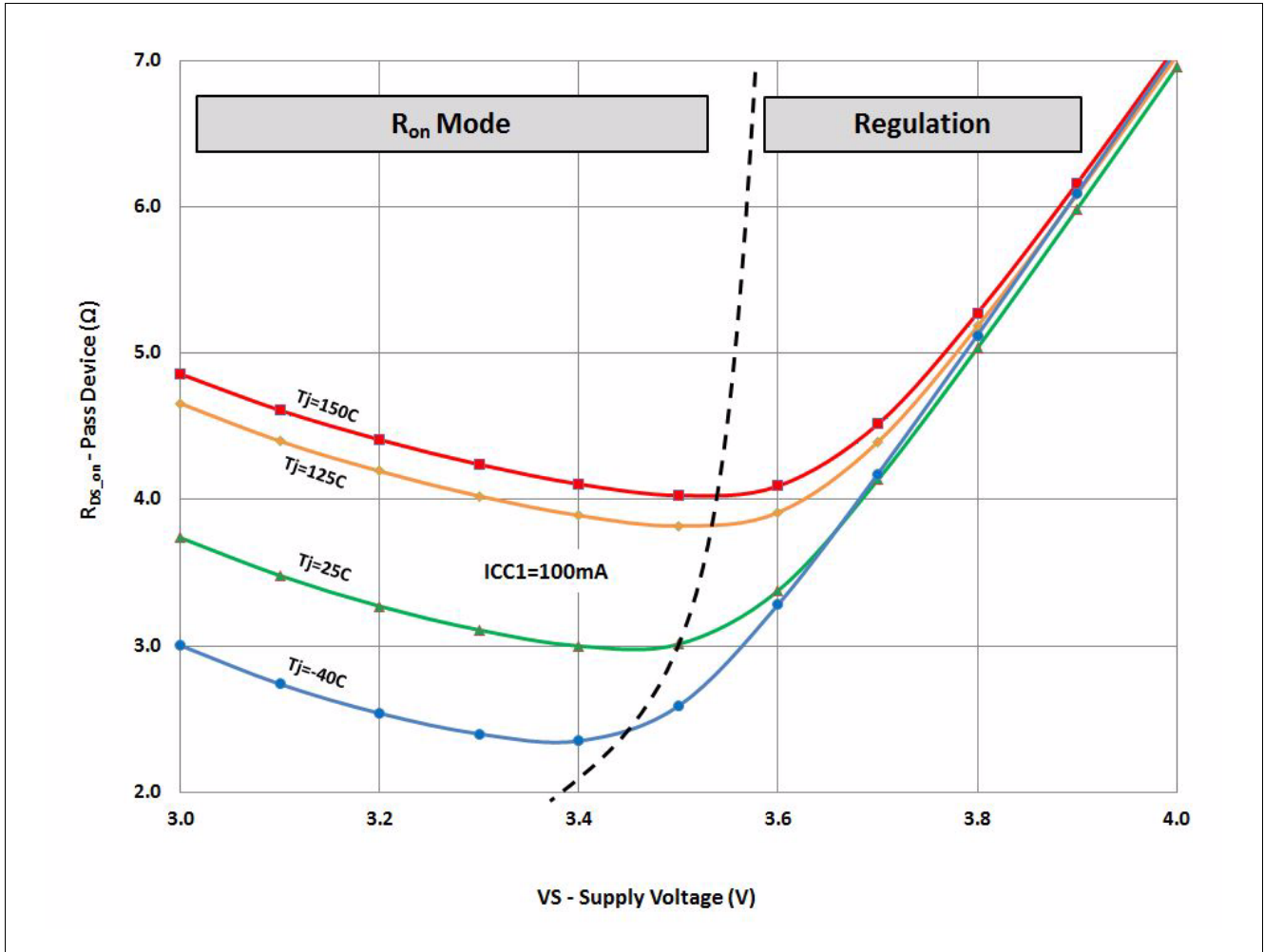
Table 9 Electrical Characteristics

$V_S = 5.5\text{ V to }28\text{ V}$ ;  $T_j = -40\text{ °C to }+150\text{ °C}$ ; all voltages with respect to ground, positive current flowing into pin (unless otherwise specified)

Parameter	Symbol	Values			Unit	Note or Test Condition	Number
		Min.	Typ.	Max.			
Output Voltage including line and Load regulation (VCC1 = 3.3V)	$V_{CC1,out5}$	3.23	3.3	3.37	V	<sup>1)</sup> SBC Normal Mode; $10\mu\text{A} < I_{VCC1} < 250\text{mA}$ $6\text{V} < V_S < 28\text{V}$	P_6.3.14
Output Voltage including line and Load regulation	$V_{CC1,out8}$	3.23	3.3	3.37	V	<sup>1)</sup> SBC Normal Mode; $10\mu\text{A} < I_{VCC1} < 150\text{mA}$	P_6.3.22
Output Voltage including line and Load regulation (VCC1 = 3.3V)	$V_{CC1,out6}$	3.29	–	3.35	V	<sup>1)2)</sup> SBC Normal Mode; $20\text{mA} < I_{VCC1} < 80\text{mA}$ $8\text{V} < V_S < 18\text{V}$ $25\text{°C} < T_j < 125\text{°C}$	P_6.3.15
Output Voltage including line and Load regulation (VCC1 = 3.3V)	$V_{CC1,out71}$	3.29	3.3	3.43	V	SBC Stop Mode; $1\text{mA} < I_{VCC1} < I_{VCC1,peak}$	P_6.3.16
Output Voltage including line and Load regulation (VCC1 = 3.3V)	$V_{CC1,out72}$	3.29	3.3	3.47	V	SBC Stop Mode; $10\mu\text{A} < I_{VCC1} < 1\text{mA}$	P_6.3.21
Output Drop	$V_{CC1,d1}$	–	–	500	mV	$I_{VCC1} = 50\text{mA}$ $V_S = 3\text{V}$	P_6.3.3
Output Drop	$V_{CC1,d2}$	–	–	500	mV	$I_{VCC1} = 150\text{mA}$ $V_S = 5\text{V}$	P_6.3.4
VCC1 Active Peak Threshold 1 (Transition threshold between low-power and high-power mode regulator)	$I_{VCC1,peak1,r}$	–	1.9	3.5	mA	<sup>2)</sup> $I_{CC1}$ rising; $V_S = 13.5\text{V}$ $-40\text{°C} < T_j < 150\text{°C}$ ; <b>I_PEAK_TH = '0'</b>	P_6.3.13
VCC1 Active Peak Threshold 1 (Transition threshold between high-power and low-power mode regulator)	$I_{VCC1,peak1,f}$	0.5	1.3	–	mA	<sup>2)</sup> $I_{CC1}$ falling; $V_S = 13.5\text{V}$ $-40\text{°C} < T_j < 150\text{°C}$ ; <b>I_PEAK_TH = '0'</b>	P_6.3.17
VCC1 Active Peak Threshold 2 (Transition threshold between low-power and high-power mode regulator)	$I_{VCC1,peak2,r}$	–	4.3	7.0	mA	<sup>2)</sup> $I_{CC1}$ rising; $V_S = 13.5\text{V}$ $-40\text{°C} < T_j < 150\text{°C}$ ; <b>I_PEAK_TH = '1'</b>	P_6.3.18
VCC1 Active Peak Threshold 2 (Transition threshold between high-power and low-power mode regulator)	$I_{VCC1,peak2,f}$	1.7	3.4	–	mA	<sup>2)</sup> $I_{CC1}$ falling; $V_S = 13.5\text{V}$ $-40\text{°C} < T_j < 150\text{°C}$ ; <b>I_PEAK_TH = '1'</b>	P_6.3.19
Overcurrent Limitation	$I_{VCC1,lim}$	250	–	1200 <sup>2)</sup>	mA	current flowing out of pin, $V_{CC1} = 0\text{V}$	P_6.3.6

**Voltage Regulator 1**

- 1) In SBC Stop Mode, the specified output voltage tolerance applies when  $I_{VCC1}$  has exceeded the selected active peak threshold ( $I_{VCC1,peak1,r}$  or  $I_{VCC1,peak2,r}$ ) but with increased current consumption.
- 2) Not subject to production test, specified by design.



**Figure 12** Typical on-resistance characterization results of VCC1 pass device during low drop operation for  $I_{CC1} = 100\text{mA}$

Voltage Regulator 1

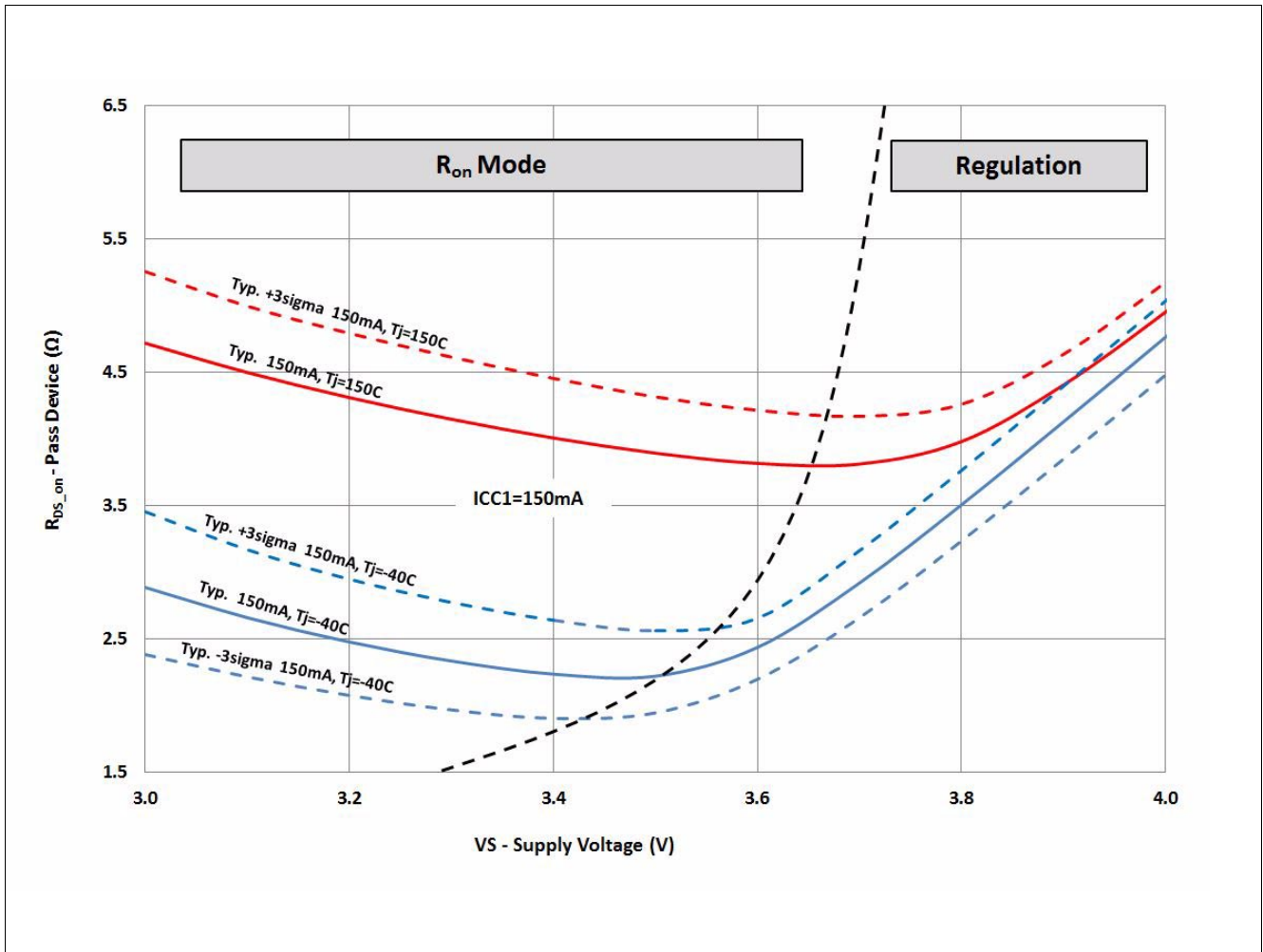
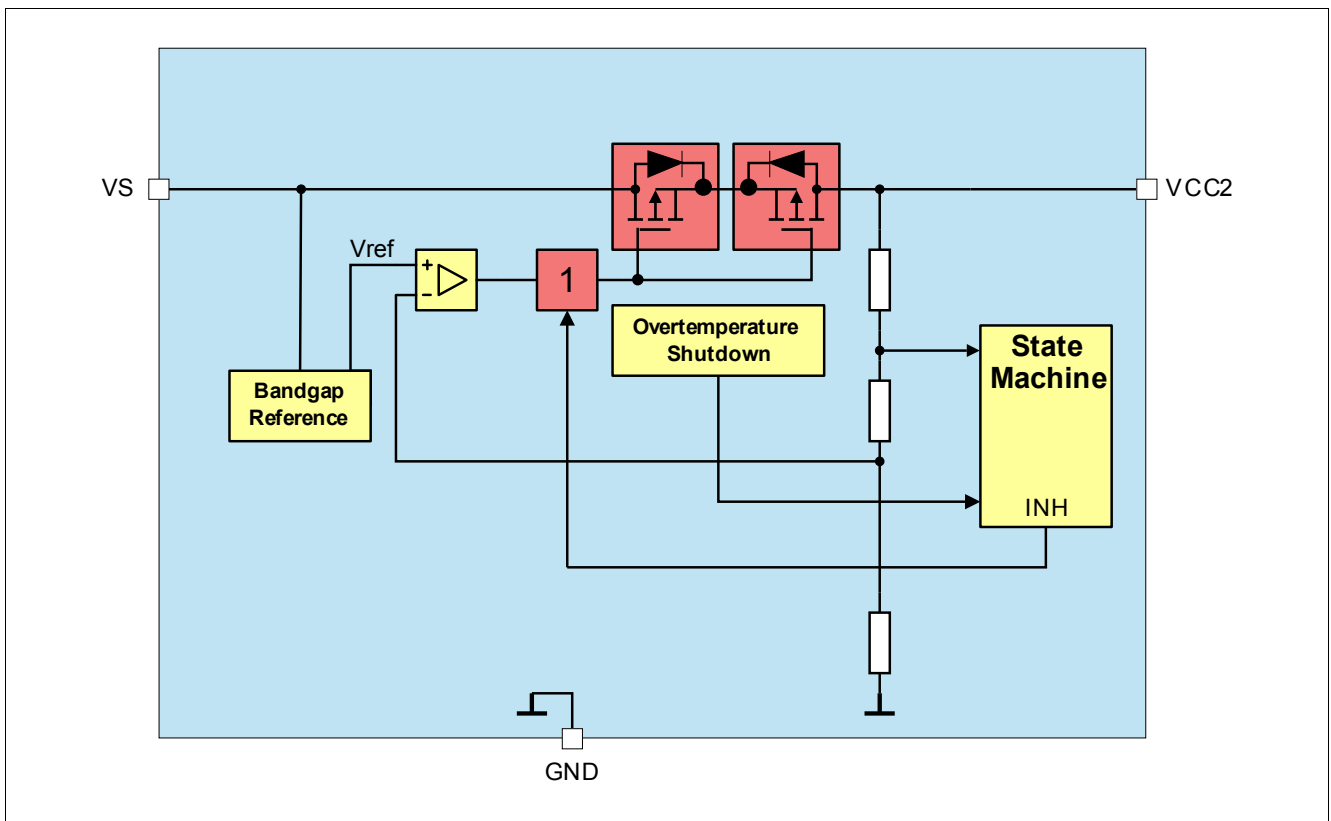


Figure 13 Characterization results of on-resistance range of VCC1 pass device during low drop operation for  $I_{CC1} = 150\text{mA}$

## Voltage Regulator 2

## 7 Voltage Regulator 2

## 7.1 Block Description



**Figure 14** Module Block Diagram

### Functional Features

- 5 V low-drop voltage regulator
- Protected against short to battery voltage, e.g. for off-board sensor supply
- Can also be used for CAN supply
- VCC2 undervoltage monitoring. Please refer to [Chapter 15.8](#) for more information
- Can be active in SBC Normal, SBC Stop, and SBC Sleep Mode (not SBC Fail-Safe Mode)
- VCC2 switch off after entering SBC Restart Mode. Switch off is latched, LDO must be enabled via SPI after shutdown.
- Overtemperature protection
- $\geq 470\text{nF}$  ceramic capacitor at output voltage for stability, with  $\text{ESR} < 1\Omega @ f = 10 \text{ kHz}$ , to achieve the voltage regulator control loop stability based on the safe phase margin (bode diagram).
- Output current capability up to  $I_{VCC2,lim}$ .

---

## Voltage Regulator 2

### 7.2 Functional Description

In SBC Normal Mode VCC2 can be switched on or off via SPI.

For SBC Stop- or Sleep Mode, the VCC2 has to be switched on or off before entering the respective SBC mode.

The regulator can provide an output current up to  $I_{VCC2,lim}$ .

For low-quiescent current reasons, the output voltage tolerance is decreased in SBC Stop Mode because only a low-power mode regulator with a lower accuracy ( $V_{CC2,out5}$ ) will be active for small loads. If the load current on VCC2 exceeds  $I_{VCC2} > I_{VCC2,peak,r}$  then the high-power mode regulator will also be enabled to support an optimum dynamic load behavior. The current consumption will then increase by typ. 2.9mA.

If the load current on VCC2 falls below the threshold ( $I_{VCC2} < I_{VCC2,peak,f}$ ), then the low-quiescent current mode is resumed again by disabling the high-power mode regulator.

Both regulators are active in SBC Normal Mode.

*Note: If the VCC2 output voltage is supplying external off-board loads, the application must consider the series resonance circuit built by cable inductance and decoupling capacitor at the load. Sufficient damping must be provided.*

#### 7.2.1 Short to Battery Protection

The output stage is protected for short to VBAT.

## Voltage Regulator 2

## 7.3 Electrical Characteristics

**Table 10** Electrical Characteristics

$V_S = 5.5\text{ V to }28\text{ V}$ ;  $T_j = -40\text{ °C to }+150\text{ °C}$ ; all voltages with respect to ground, positive current flowing into pin (unless otherwise specified)

Parameter	Symbol	Values			Unit	Note or Test Condition	Number
		Min.	Typ.	Max.			
Output Voltage including line and Load regulation (SBC Normal Mode)	$V_{CC2,out1}$	4.9	5.0	5.1	V	<sup>1)</sup> SBC Normal Mode; $10\mu\text{A} < I_{VCC2} < 100\text{mA}$ $6.5\text{V} < V_S < 28\text{V}$	P_7.3.1
Output Voltage including line and Load regulation (SBC Normal Mode)	$V_{CC2,out2}$	4.9	5.0	5.1	V	<sup>1)</sup> SBC Normal Mode; $10\mu\text{A} < I_{VCC2} < 80\text{mA}$ $6\text{V} < V_S < 28\text{V}$	P_7.3.16
Output Voltage including line and Load regulation (SBC Normal Mode)	$V_{CC2,out3}$	4.9	5.0	5.1	V	<sup>1)</sup> SBC Normal Mode; $10\mu\text{A} < I_{VCC2} < 40\text{mA}$	P_7.3.2
Output Voltage including line and Load regulation (SBC Normal Mode)	$V_{CC2,out4}$	4.97	–	5.07	V	<sup>2)</sup> SBC Normal Mode; $10\mu\text{A} < I_{VCC2} < 5\text{mA}$ $8\text{V} < V_S < 18\text{V}$ $25\text{°C} < T_j < 125\text{°C}$	P_7.3.14
Output Voltage including line and Load regulation (SBC Stop/Sleep Mode)	$V_{CC2,out5}$	4.9	5.05	5.2	V	Stop, Sleep Mode; $1\text{mA} < I_{VCC2} < I_{VCC2,lpeak}$	P_7.3.3
Output Voltage including line and Load regulation (SBC Stop/Sleep Mode)	$V_{CC2,out6}$	4.9	5.05	5.25	V	Stop, Sleep Mode; $10\mu\text{A} < I_{VCC2} < 1\text{mA}$	P_7.3.18
Output Drop	$V_{CC2,d1}$	–	–	500	mV	$I_{VCC2} = 30\text{mA}$ $V_S = 5\text{V}$	P_7.3.4
VCC2 Active Peak Threshold (Transition threshold between low-power and high-power mode regulator)	$I_{VCC2,lpeak,r}$	–	1.9	3.5	mA	<sup>2)</sup> $I_{CC2}$ rising; $V_S = 13.5\text{V}$ $-40\text{°C} < T_j < 150\text{°C}$	P_7.3.15
VCC2 Active Peak Threshold (Transition threshold between high-power and low-power mode regulator)	$I_{VCC2,lpeak,f}$	0.5	1.3	–	mA	<sup>2)</sup> $I_{CC2}$ falling; $V_S = 13.5\text{V}$ $-40\text{°C} < T_j < 150\text{°C}$	P_7.3.17
Overcurrent limitation	$I_{VCC2,lim}$	100	–	750 <sup>2)</sup>	mA	current flowing out of pin, $V_{CC2} = 0\text{V}$	P_7.3.5

1) In SBC Stop Mode, the specified output voltage tolerance applies when  $I_{VCC2}$  has exceeded the selected active peak threshold ( $I_{VCC2,lpeak,r}$ ) but with increased current consumption.

2) Not subject to production test, specified by design.



Voltage Regulator 2

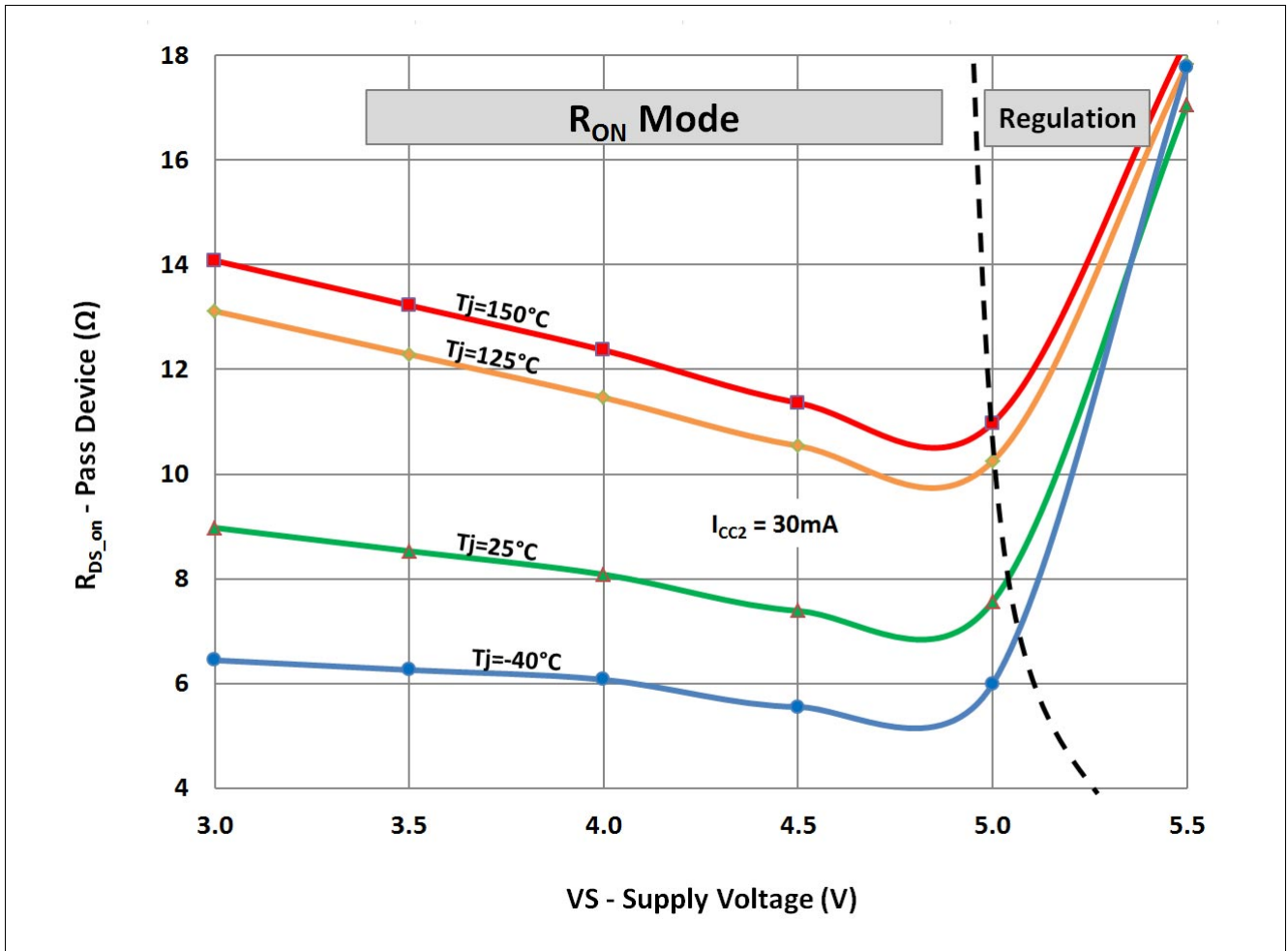


Figure 15 Typical on-resistance of VCC2 pass device during low drop operation for  $I_{CC2} = 30\text{mA}$

Voltage Regulator 2

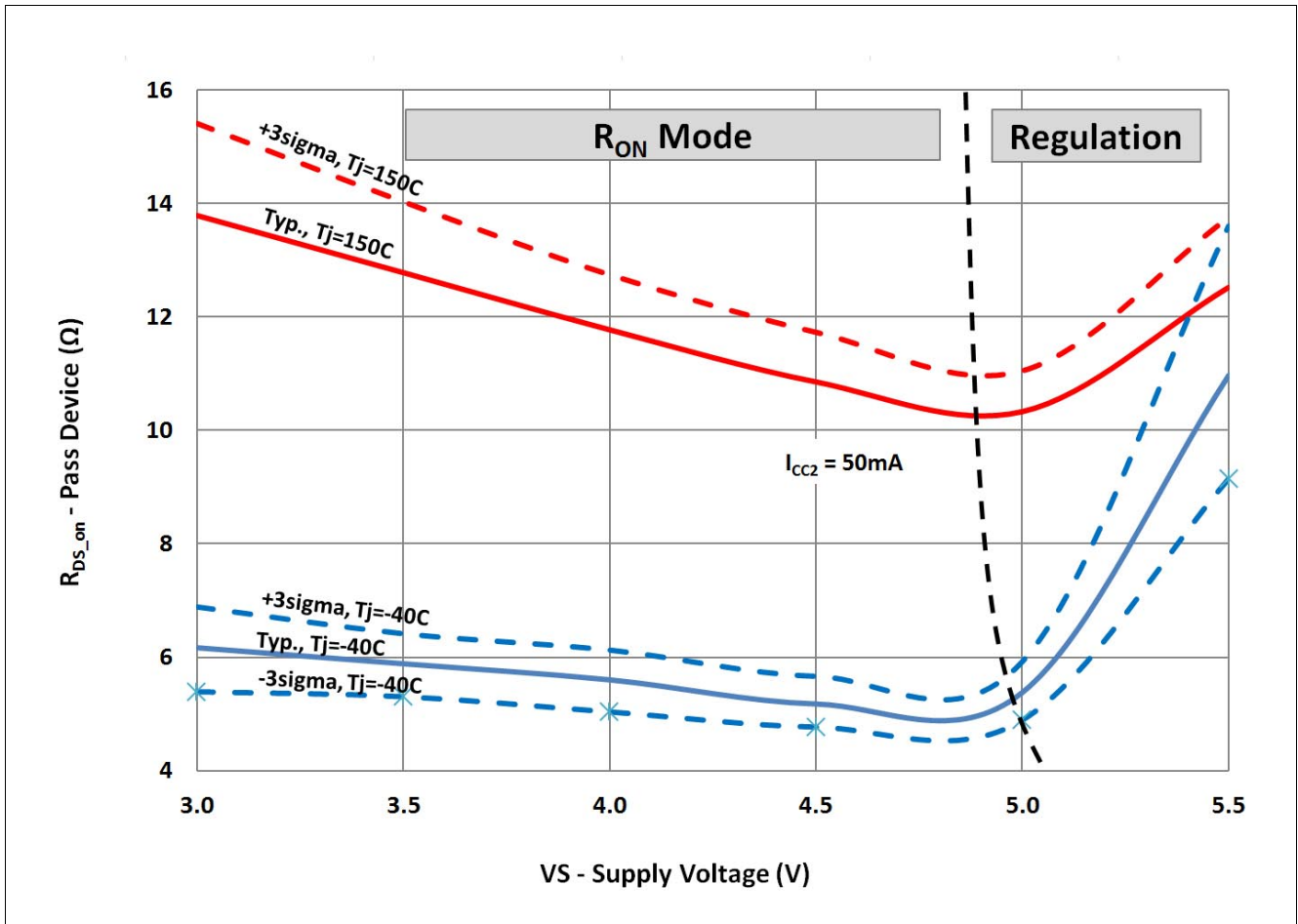


Figure 16 On-resistance range of VCC2 pass device during low drop operation for  $I_{CC2} = 50mA$

## External Voltage Regulator 3

## 8 External Voltage Regulator 3

## 8.1 Block Description

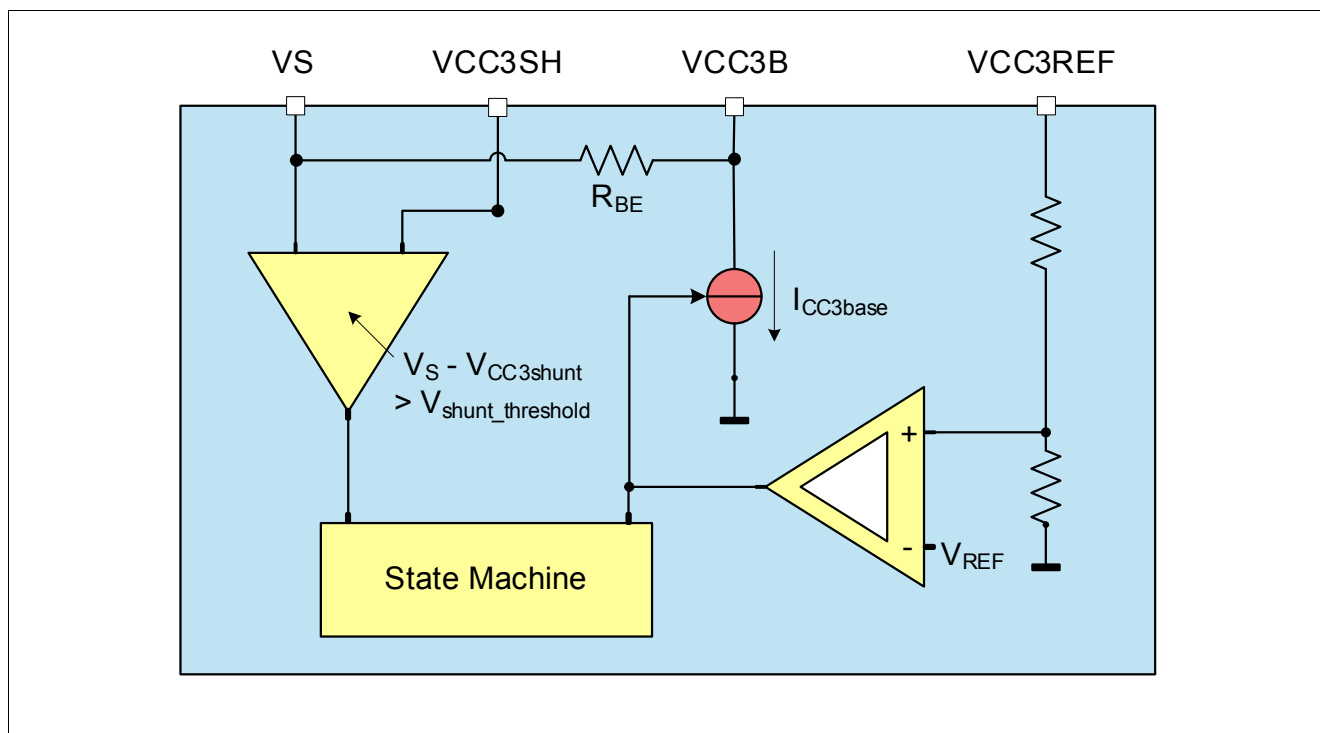


Figure 17 Functional Block Diagram

## Functional Features

- Low-drop voltage regulator with external PNP transistor (up to 350mA with 470mΩ shunt resistor)
- Four high-voltage pins are used: VS, VCC3B, VCC3SH, VCC3REF
- Configurable as stand-alone regulator (3.3V or 1.8V output voltage selectable via SPI) or in load-sharing mode with VCC1 (3.3V output voltage)
- $\geq 4.7\mu\text{F}$  ceramic capacitor at output voltage for stability, with ESR  $< 150\text{m}\Omega$  @  $f = 10\text{ kHz}$  to achieve the voltage regulator control loop stability based on the safe phase margin (bode diagram).
- Overcurrent limitation with external shunt in stand-alone configuration
- Adjustable load current sharing ratio between VCC1 and VCC3 for load-sharing configuration
- Undervoltage shutdown in stand-alone configuration only

Table 11 <sup>1)</sup>External Voltage Regulator Configurations depending on VCC1 output voltage

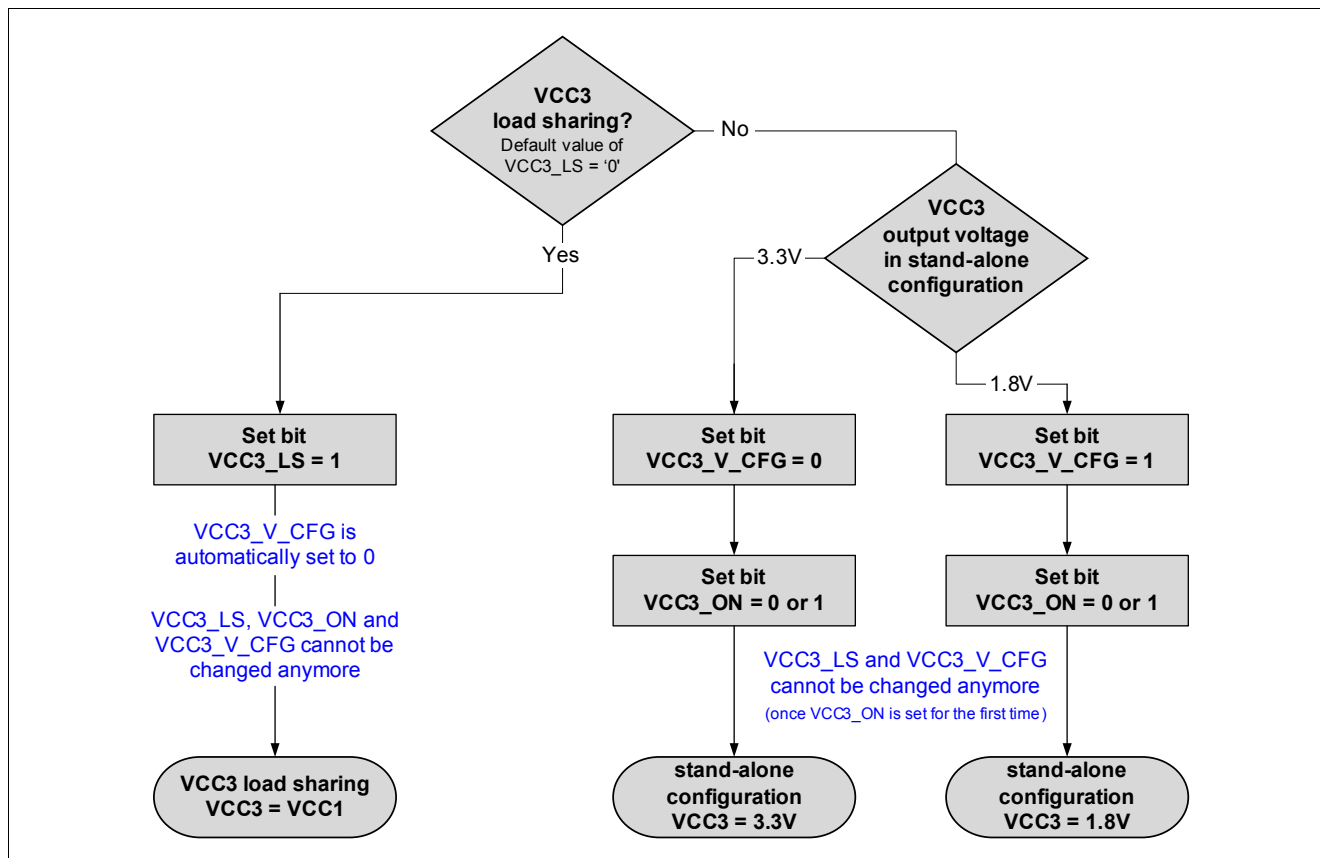
VCC1 configuration	VCC3 voltage for <b>VCC3_V_CFG = 0</b>	VCC3 voltage for <b>VCC3_V_CFG = 1</b>
VCC1 = 3.3V	VCC3 = 3.3V	VCC3 = 1.8V

1) This settings are valid only for the VCC3 stand-alone configuration. The bit **VCC3\_V\_CFG** is ignored for VCC3 load sharing configuration

## External Voltage Regulator 3

### 8.2 Functional Description

The external voltage regulator can be used as an independent voltage regulator or in load-sharing mode with VCC1. Setting **VCC3\_ON** in the **M\_S\_CTRL** register in SBC Normal Mode sets the stand-alone configuration of VCC3 as an independent voltage regulator. The load sharing configuration is set via the SPI bit **VCC3\_LS** in the **HW\_CTRL** register.



**Figure 18** Selecting the Configuration of the VCC3 Regulator

Depending on the configuration the regulator will act in the respective SBC Mode as described in [Table 12](#). After the VCC3 configuration has been selected, it cannot be changed anymore.

In stand-alone configuration the maximum current  $I_{CC3max}$  is defined by the current limitation determined by the used shunt. In load sharing configuration, the shunt is used to determine the current ratio between VCC1 and VCC3. Since the junction temperature of the external PNP transistor cannot be sensed by the SBC, it cannot be protected against overtemperature by the SBC. Therefore the thermal behavior has to be analyzed by the application.

For low-quiescent current reasons, the output voltage tolerance is decreased in SBC Stop Mode because a low-power mode regulator with a lower accuracy will be active for small loads. If the base current on VCC3 exceeds  $I_{VCC3base} > I_{VCC3base, I_{peak,r}}$  then the high-power mode regulator is enabled additionally to support an optimum dynamic load behavior. If the base current on VCC3 falls below the threshold ( $I_{VCC3base} < I_{VCC3base, I_{peak,r}}$ ), then the low-quiescent current consumption is resumed again by disabling the high-power mode regulator.

Only the high-power mode regulator is active in SBC Normal Mode.

The status of VCC3 is reported in the **SUP\_STAT\_2** SPI register. The regulator will switch OFF in case of VS dropping below **VS\_UV** regardless of the VCC3 configuration and will be automatically enabled again when exceeding this threshold voltage unless the control bit **VCC3\_VS\_UV\_OFF** is set, i.e. in order to keep VCC3 enabled below **VS\_UV** the bit **VCC3\_VS\_UV\_OFF** must be set. VCC3 will also stay active in SBC Stop Mode

## External Voltage Regulator 3

when the bit **VCC3\_LS\_STP\_ON** is set and when load sharing is configured (for detailed protection features see [Chapter 15.7](#) and [Chapter 16.3](#)).

**Table 12 External Voltage Regulator State by SBC Mode**

SBC Mode	Load Sharing Mode <sup>1)</sup>	Independent Voltage Regulator
INIT Mode	OFF	OFF
Normal Mode	Configurable	Configurable
Stop Mode	OFF/Fixed <sup>2)</sup>	Fixed
Sleep Mode	OFF	Fixed
Restart Mode	ON or ramping	Fixed
Fail-Safe Mode	OFF	OFF

1) Behaves as VCC1 and has to be configured in SBC Normal Mode

2) Load Sharing operation in SBC Stop Mode is by default disabled for power saving reasons but **VCC3\_LS** bit will stay set. However, it can be also configured via the SPI bit **VCC3\_LS\_STP\_ON** to stay enabled in SBC Stop Mode.

*Note:* The configuration of the VCC3 voltage regulator behavior must be done immediately after power-up of the device and cannot be changed afterwards as long as the device is supplied.

*Note:* As soon as the bit **VCC3\_ON** or **VCC3\_LS** is set for the first time, the configuration for VCC3 cannot be changed anymore. This configuration is valid - also after a SBC Soft Reset - as long as the SBC is powered.

*Note:* If the VCC3 output voltage is supplying external off-board loads, the application must consider the series resonance circuit built by cable inductance and decoupling capacitor at the load. Sufficient damping must be provided (e.g. a 100Ω resistor between the PNP collector and VCC3REF with 10μF capacitor on collector - see also [Figure 19](#)).

### 8.2.1 External Voltage Regulator as Independent Voltage Regulator

Configured as an independent voltage regulator the SBC offers with VCC3 a third supply which could be used as off-board supply e.g. for sensors due to the integrated HV pins VCC3B, VCC3SH, VCC3REF.

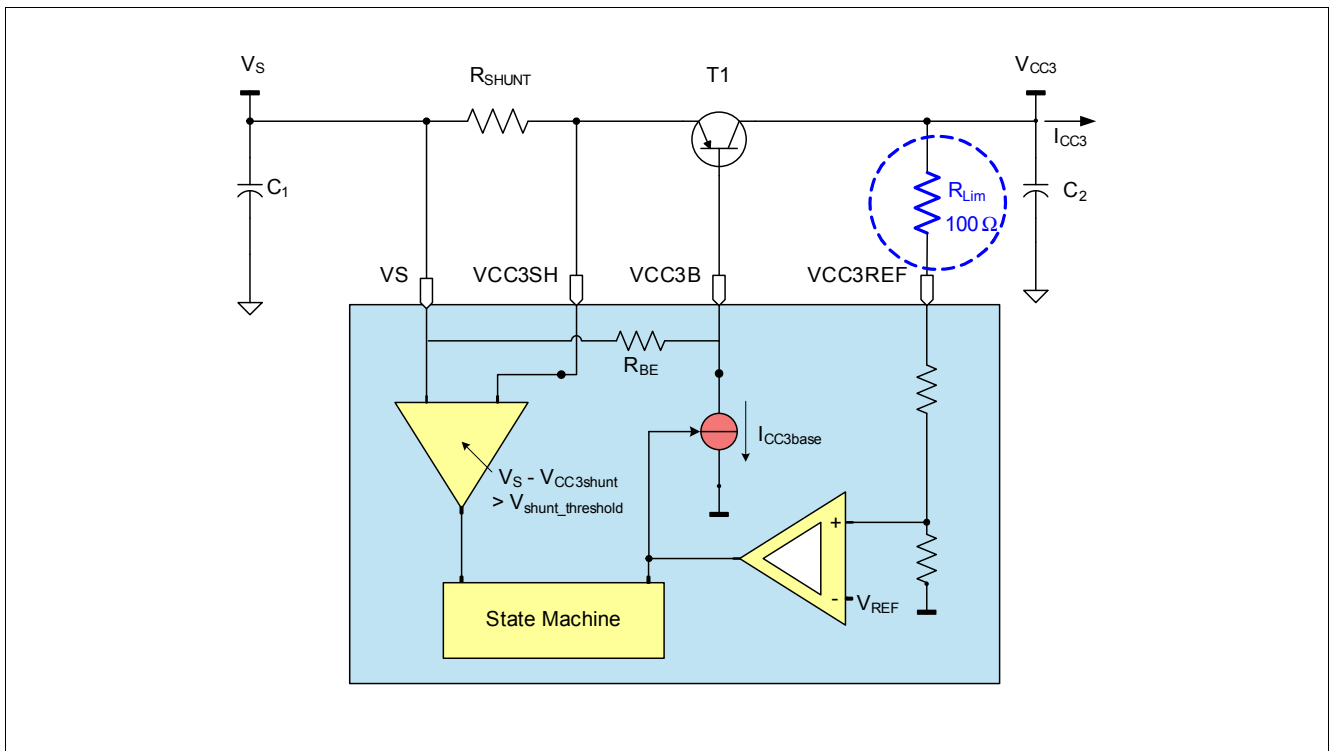
This configuration is set and locked by enabling **VCC3\_ON** while keeping **VCC3\_LS** = 0. VCC3 can be switched ON or OFF but the configuration cannot be changed anymore. However, the **SPI\_FAIL** is not set while trying to change the configuration.

An overcurrent limitation function is realized with the external shunt (see [Chapter 8.4](#) for calculating the desired shunt value) and the output current shunt voltage threshold ( $V_{shunt\_threshold}$ ). If this threshold is reached, then ICC3 is limited and only the current limitation bit **VCC3\_OC** is set (no other reaction) and can be cleared via SPI once the overcurrent condition is not present anymore. If the overcurrent limitation feature is not needed, then connect the pins VCC3SH and VS together.

In this configuration VCC3 has the undervoltage signalization enabled and an undervoltage event is signaled with the bit **VCC3\_UV** in the **SUP\_STAT\_2** SPI register.

*Note:* To avoid undesired current consumption increase of the device it must be ensured that VCC3 is not connected to VCC1 in this configuration.

## External Voltage Regulator 3



**Figure 19** Protecting the VCC3 against inductive short circuits when configured as an independent voltage regulator for off-board supply

### 8.2.2 External Voltage Regulator in Load Sharing Mode

The purpose of the load sharing mode is to increase the total current capability of VCC1 without increase of the power dissipation within the SBC. The load current is shared between the VCC1 internal regulator and the external PNP transistor of VCC3. **Figure 20** shows the setup for Load Sharing. Load Sharing is active in SBC Normal Mode. It can also be configured via SPI to stay active in SBC Stop Mode.

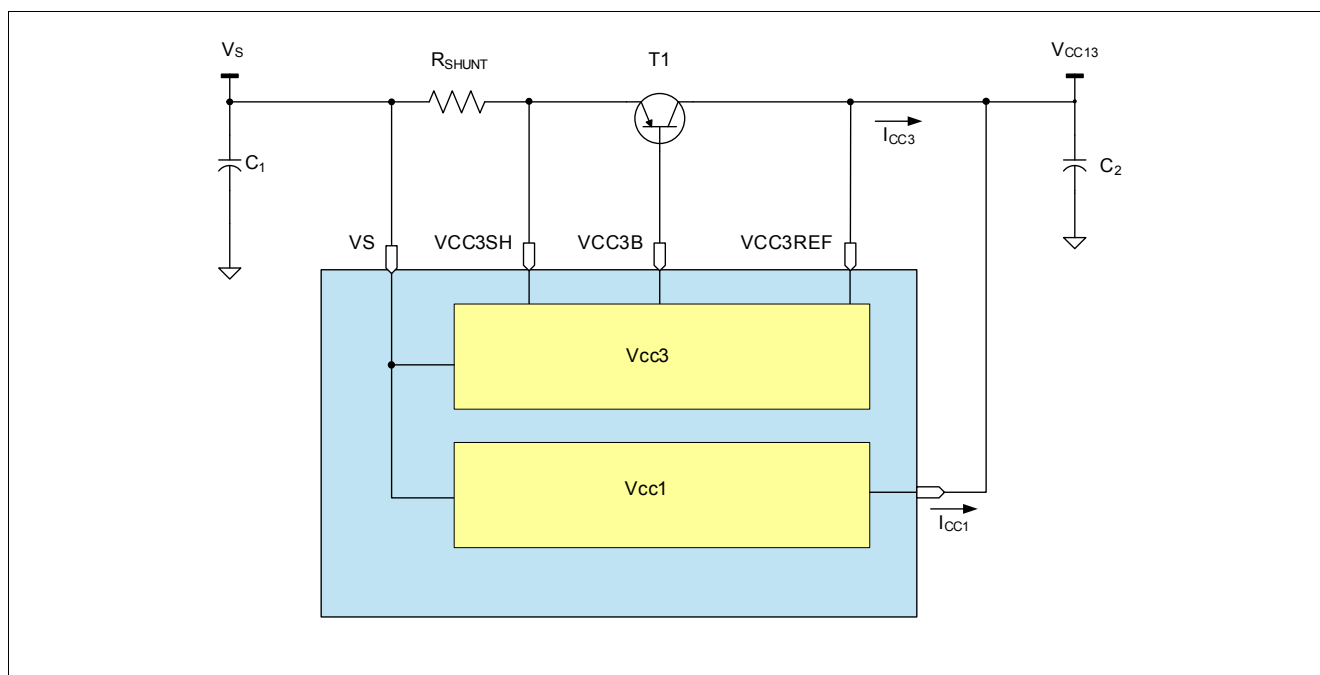
An input voltage up to  $V_{Sx,MAX}$  is regulated to  $V_{CC3,nom} = 3.3\text{ V}$  with a precision of  $\pm 2\%$  when used in the load sharing configuration in SBC Normal Mode.

This configuration is set and locked by enabling **VCC3\_LS** for the first time while **VCC3\_ON** has no function, i.e. keep **VCC3\_ON** = 0. Trying to change the VCC3 configuration after **VCC3\_LS** has been set will result in the **SPI\_FAIL** bit being set and keeping the VCC3 configurations unchanged. Load sharing will be automatically disabled (only if **VCC3\_LS\_STP\_ON** = 0) during SBC Stop Mode due to power saving reasons but the bit will remain set to automatically switch back on after returning to SBC Normal Mode. It must be ensured that the same VCC3 output voltage level is selected as for VCC1.

In this configuration VCC3 has no undervoltage signalization. VCC3 shuts down if Fail-Safe Mode is reached, e.g. due to undervoltage shutdown ( $V_{S,UV}$  monitoring).

VCC3 has no overcurrent limitation in this configuration and the shunt resistor is defining the load sharing ratio between the VCC1 and VCC3 load currents (see **Equation (8.2)** in **Chapter 8.4**). Thus, no overcurrent condition **VCC3\_OC** will be signaled in this configuration.

## External Voltage Regulator 3



**Figure 20** VCC3 in Load Sharing Configuration

### 8.3 External Components

Characterization is performed with the BCP52-16 from Infineon ( $I_{CC3} < 200$  mA) and with MJD253. Other PNP transistors can be used. However, the functionality must be checked in the application.

**Figure 20** shows one hardware set up used.

**Table 13** Bill of Materials for the  $V_{CC3}$  Function with and without load sharing configuration

Device	Vendor	Reference / Value
C2	Murata	10 $\mu$ F/10 V GCM31CR71A106K64L
RSHUNT	-	1 $\Omega$ (with / without LS)
T1	Infineon	BCP52-16

**Note:** The SBC is not able to ensure a thermal protection of the external PNP transistor. The power handling capabilities for the application must therefore be chosen according to the selected PNP device, the PCB layout and properties of the application to prevent thermal damage, e.g. via the shunt current limitation in stand alone configuration or by selecting the proper  $ICC1/ICC3$  ratio in load-sharing configuration.

**Note:** To ensure an optimum EMC behavior of the VCC3 regulator when the VCC3 output is leaving the PCB, it is necessary to optimize the PCB layout to have the PNP very close to the SBC. If this is not sufficient or possible, an external capacitance should be placed to the off-board connector (see also [Chapter 17.1](#)).

## External Voltage Regulator 3

### 8.4 Calculation of $R_{SHUNT}$

As a independent regulator, the maximum current  $I_{CC3max}$  where the limit starts and the bit  $I_{CC3} > I_{CC3max}$  is set is determined by the shunt resistor  $R_{SHUNT}$  and the Output Current Shunt Voltage Threshold  $V_{shunt\_threshold}$ .

The resistor can be calculated as following:

$$R_{SHUNT} = \frac{U_{shunt\_threshold}}{I_{CC3max}} \quad (8.1)$$

If VCC3 is configured for load sharing, then the shunt resistor determines the load sharing ratio between VCC1 and VCC3. The ratio can be calculated as following:

$$\frac{I_{CC3}}{I_{CC1}} = \frac{110 \text{ } \Omega / 105 - 15 \text{ mV}}{R_{SHUNT}} / I_{CC1} \quad (a) \quad (8.2)$$

$$I_{CC3} = \frac{I_{CC1} \cdot 110 \text{ } \Omega / 105 - 15 \text{ mV}}{R_{SHUNT}} \quad (b)$$

Example: A shunt resistor with 470m $\Omega$  and a load current of 100mA out of VCC1 would result in  $I_{CC3} = 191\text{mA}$ .

### 8.5 Unused Pins

In case the VCC3 is not used in the application, it is recommended to connect the unused pins of VCC3 as followed:

- Connect VCC3SH to VS or leave open;
- Leave VCC3B open;
- Leave VCC3REF open
- Do not enable the VCC3 via SPI as this leads to increased current consumption



## External Voltage Regulator 3

### 8.6 Electrical Characteristics

$V_S = 5.5\text{ V to }28\text{ V}$ ;  $T_j = -40\text{ °C to }+150\text{ °C}$ ; SBC Normal Mode; all outputs open; all voltages with respect to ground; positive current defined flowing into pin; unless otherwise specified.

**Table 14 Electrical Characteristics**

Parameter	Symbol	Values			Unit	Note or Test Condition	Number
		Min.	Typ.	Max.			
<b>Parameters independent from Test Set-up</b>							
External Regulator Control Drive Current Capability	$I_{VCC3base}$	40	60	80	mA	$V_{VCC3base} = 13.5\text{ V}$	P_8.6.1
Input Current $V_{CC3ref}$	$I_{VCC3ref}$	0	3	10	$\mu\text{A}$	$V_{VCC3ref} = 3.3\text{ V}$	P_8.6.2
Input Current $V_{CC3}$ Shunt Pin	$I_{VCC3shunt}$	0	3	10	$\mu\text{A}$	$V_{VCC3shunt} = V_S$	P_8.6.3
Output Current Shunt Voltage Threshold	$V_{shunt\_threshold}$	180	245	310	mV	<sup>1)</sup>	P_8.6.6
Current increase regulation reaction time	$t_{rlinc}$	–	–	5	$\mu\text{s}$	<sup>4)</sup> $V_{CC3} = 3.3\text{ V to }0\text{ V}$ ; $I_{CC3base} = 20\text{ mA}$ <b>Figure 21</b>	P_8.6.7
Current decrease regulation reaction time	$t_{rldec}$	–	–	5	$\mu\text{s}$	<sup>4)</sup> $V_{CC3} = 0\text{ V to }3.3\text{ V}$ ; $I_{CC3base} = 20\text{ mA}$ <b>Figure 21</b>	P_8.6.8
Leakage current of VCC3base when VCC3 disabled	$I_{VCC3base\_lk}$	–	–	5	$\mu\text{A}$	$V_{CC3base} = V_S$ ; $T_j = 25\text{ °C}$	P_8.6.9
Leakage current of $V_{CC3shunt}$ when VCC3 disabled	$I_{VCC3shunt\_lk}$	–	–	5	$\mu\text{A}$	$V_{CC3shunt} = V_S$ ; $T_j = 25\text{ °C}$	P_8.6.11
Base to emitter resistor	$R_{BE}$	120	150	185	k $\Omega$	$V_{CC3} = \text{OFF}$ ;	P_8.6.12
Active Peak Threshold VCC3 (Transition threshold between low-power and high-power mode regulator)	$I_{VCC3base\_lpeak,r}$	–	50	65	$\mu\text{A}$	<sup>4)</sup> Drive current $I_{VCC3base}$ rising $V_S = 13.5\text{ V}$ ; $-40\text{ °C} < T_j < 150\text{ °C}$	P_8.6.33
Active Peak Threshold VCC3 (Transition threshold between high-power and low-power mode regulator)	$I_{VCC3base\_lpeak,f}$	15	30	–	$\mu\text{A}$	<sup>4)</sup> Drive current $I_{VCC3base}$ falling $V_S = 13.5\text{ V}$ ; $-40\text{ °C} < T_j < 150\text{ °C}$	P_8.6.34
<b>Parameters dependent on the Test Set-up (with external PNP device MJD-253)</b>							
External Regulator Output Voltage ( $V_{CC3} = 3.3\text{ V}$ )	$V_{CC3.out1}$	3.23	3.3	3.37	V	<sup>2)</sup> SBC Normal Mode; load sharing configuration with 470 m $\Omega$ shunt resistor; $10\text{ }\mu\text{A} < I_{VCC1} + I_{VCC3} < 300\text{ mA}$ ;	P_8.6.26

## External Voltage Regulator 3

Table 14 Electrical Characteristics (cont'd)

Parameter	Symbol	Values			Unit	Note or Test Condition	Number
		Min.	Typ.	Max.			
External Regulator Output Voltage (VCC3 = 3.3V)	$V_{CC3,out4}$	3.23	3.3V	3.37	V	SBC Normal Mode; stand-alone configuration $10\text{ mA} < I_{VCC3} < 300\text{ mA}$ ;	P_8.6.22
External Regulator Output Voltage (VCC3 = 3.3V)	$V_{CC3,out5}$	3.15	3.3V	3.45 <sup>3)</sup>	V	SBC Stop-, Sleep Mode; Stand-alone configuration $10\mu\text{A} < I_{VCC3} < I_{VCC3\_peak,r}$ <sup>5)</sup>	P_8.6.23
External Regulator Output Voltage (VCC3 = 1.8V)	$V_{CC3,out6}$	1.75	1.8	1.85	V	<sup>2)</sup> SBC Normal Mode; stand-alone configuration $10\text{ mA} < I_{CC3} < 300\text{ mA}$ ;	P_8.6.24
External Regulator Output Voltage (VCC3 = 1.8V)	$V_{CC3,out7}$	1.70	1.8	1.90 <sup>3)</sup>	V	<sup>2)</sup> SBC Stop-, Sleep Mode; Stand-alone configuration $10\mu\text{A} < I_{CC3} < I_{VCC3\_peak,r}$ <sup>5)</sup> ;	P_8.6.25
Load Sharing Ratio ICC1 : ICC3	$Ratio_{LS\_1,VCC3}$	1 : 1.35	1 : 1.9	1 : 2.45	–	<sup>4)5)</sup> $6.0\text{V} < V_S < 28\text{V}$ ; SBC Normal Mode; LS ratio for a 470 mΩ shunt resistor and total load current of 300mA	P_8.6.16
Load Sharing Ratio ICC1 : ICC3	$Ratio_{LS\_2,VCC3}$	1 : 0.67	1 : 0.95	1 : 1.23	–	<sup>4)5)</sup> $6.0\text{V} < V_S < 28\text{V}$ ; SBC Normal Mode; LS ratio for a 1 Ω shunt resistor and total load current of 300mA	P_8.6.20
Load Sharing Ratio ICC1 : ICC3	$Ratio_{LS\_3,VCC3}$	1 : 1.50	1 : 1.95	1 : 2.40	–	<sup>4)5)</sup> $T_j = 150^\circ\text{C}$ ; $8.0\text{V} < V_S < 18\text{V}$ ; SBC Normal Mode; LS ratio for a 470 mΩ shunt resistor and total load current of 300mA	P_8.6.27
Load Sharing Ratio ICC1 : ICC3	$Ratio_{LS\_4,VCC3}$	1 : 0.75	1 : 0.98	1 : 1.21	–	<sup>4)5)</sup> $T_j = 150^\circ\text{C}$ ; $8.0\text{V} < V_S < 18\text{V}$ ; SBC Normal Mode; LS ratio for a 1 Ω shunt resistor and total load current of 300mA	P_8.6.28

1) Threshold at which the current limitation starts to operate. This threshold is only active when VCC3 is configured for stand-alone configuration.

2) Tolerance includes load regulation and line regulation.

### External Voltage Regulator 3

- 3) At  $T_j > 125^\circ\text{C}$ , the power transistor leakage could be increased, which has to be added to the quiescent current of the application independently if the regulator is turned on/off. To prevent an overvoltage condition at no load due to this increased leakage, an internal clamping structure will automatically turn on at typ. 200mV above the upper limit of the programmed output voltage.
- 4) Not subject to production test, specified by design.
- 5) a) Ratio will change depending on the chosen shunt resistor which value is correlating to the maximum power dissipation of the PNP pass device. See [Chapter 8.4](#) for the ratio calculation. The ratio will also change at low-drop operation.  
For supply voltages of  $5.5\text{V} < V_S < 6\text{V}$  the accuracy applies only for a total load current of 250mA.  
The load sharing ratio in SBC Stop Mode has +/-10% wider limits than specified.  
  
b) The output voltage precision in load sharing in SBC Stop Mode is according to  $V_{CC1} \pm 4\%$  or better for loads up to 20mA and +/-2% with loads greater than 20mA.  
In SBC Normal the +/-2% precision for 5V/3.3V tolerance is valid regardless of the applied load.

*Note: There is no thermal protection available for the external PNP transistor. Therefore, the application must be designed to avoid overheating of the PNP via the shunt current limitation in stand alone configuration and by selecting the proper ICC1/ICC3 ratio in load-sharing configuration.*

*Note: In SBC Stop Mode, the same output voltage tolerance applies as in SBC Normal Mode when  $I_{VCC3}$  has exceeded the selected active peak threshold ( $I_{VCC3base, I_{peak}}$ ) but with increased current consumption.*

External Voltage Regulator 3

Timing diagram for regulator reaction time “current increase regulation reaction time” and “current decrease regulation reaction time”

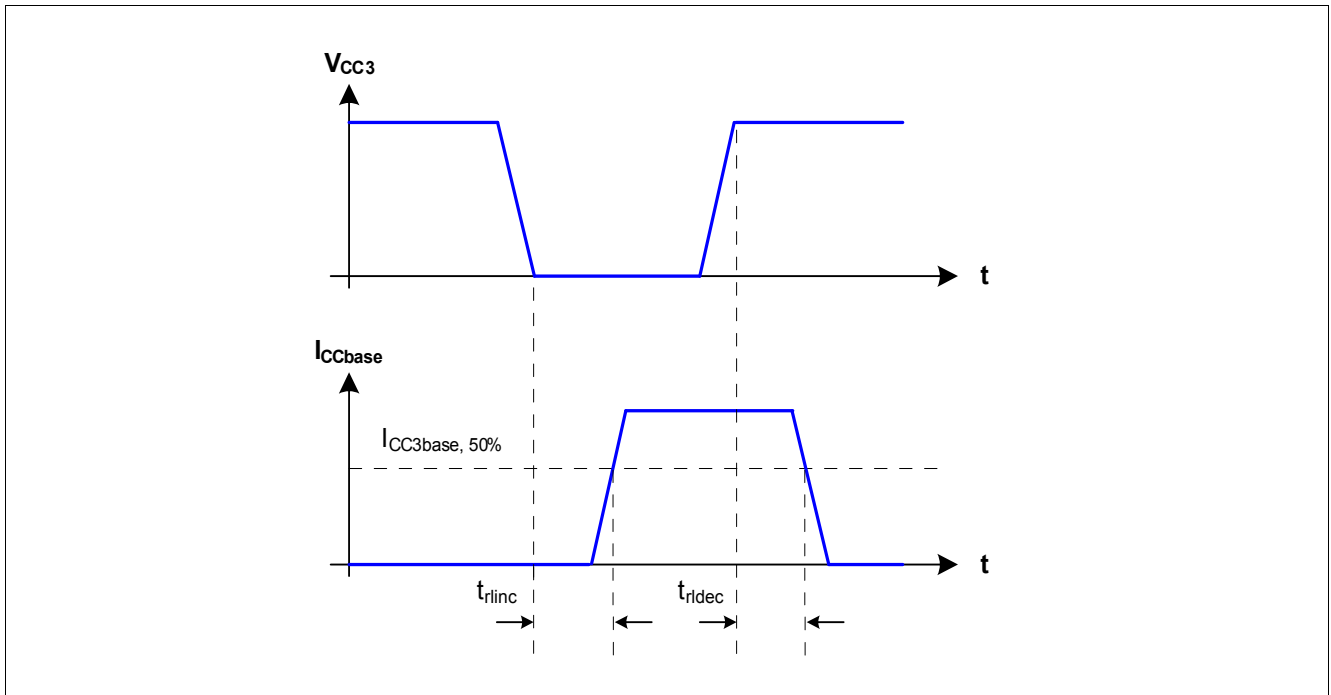


Figure 21 Regulator Reaction Time

External Voltage Regulator 3

Typical Load Sharing Characteristics using the BCP52-16 PNP transistor and a 1 Ω shunt resistor

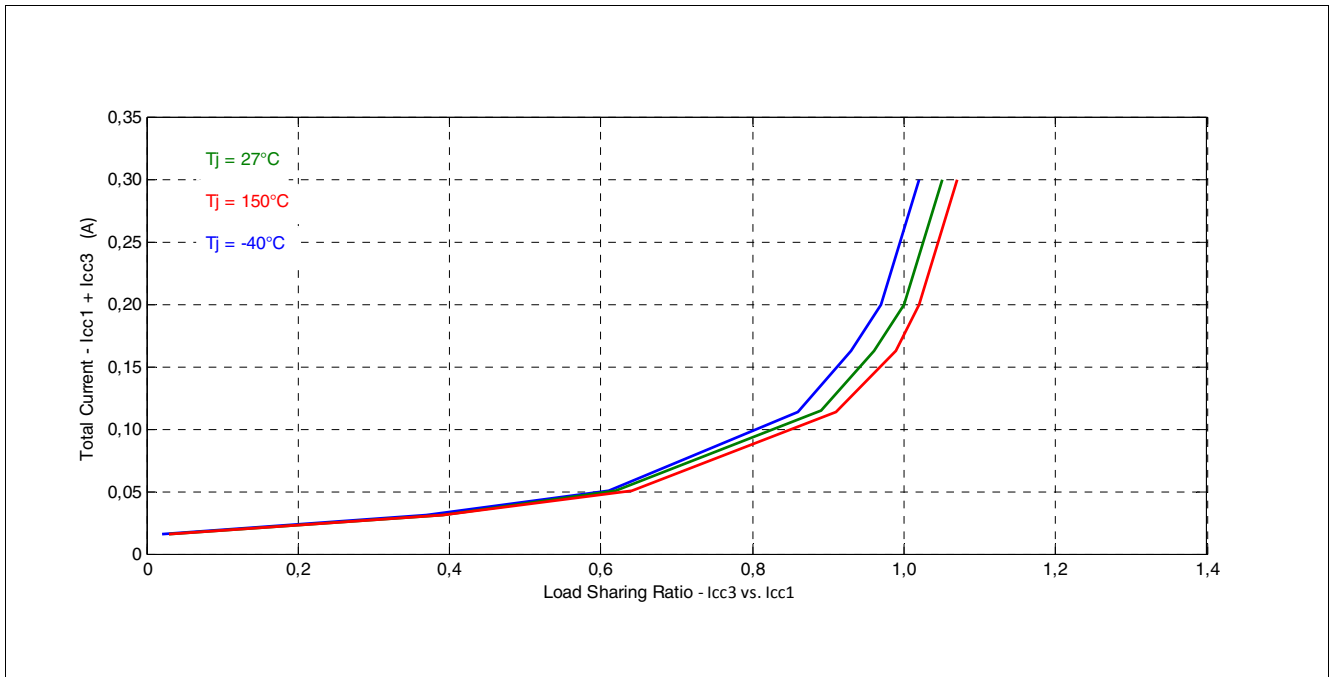


Figure 22 Load Sharing Ratio ICC1 : ICC3 vs. the total load current

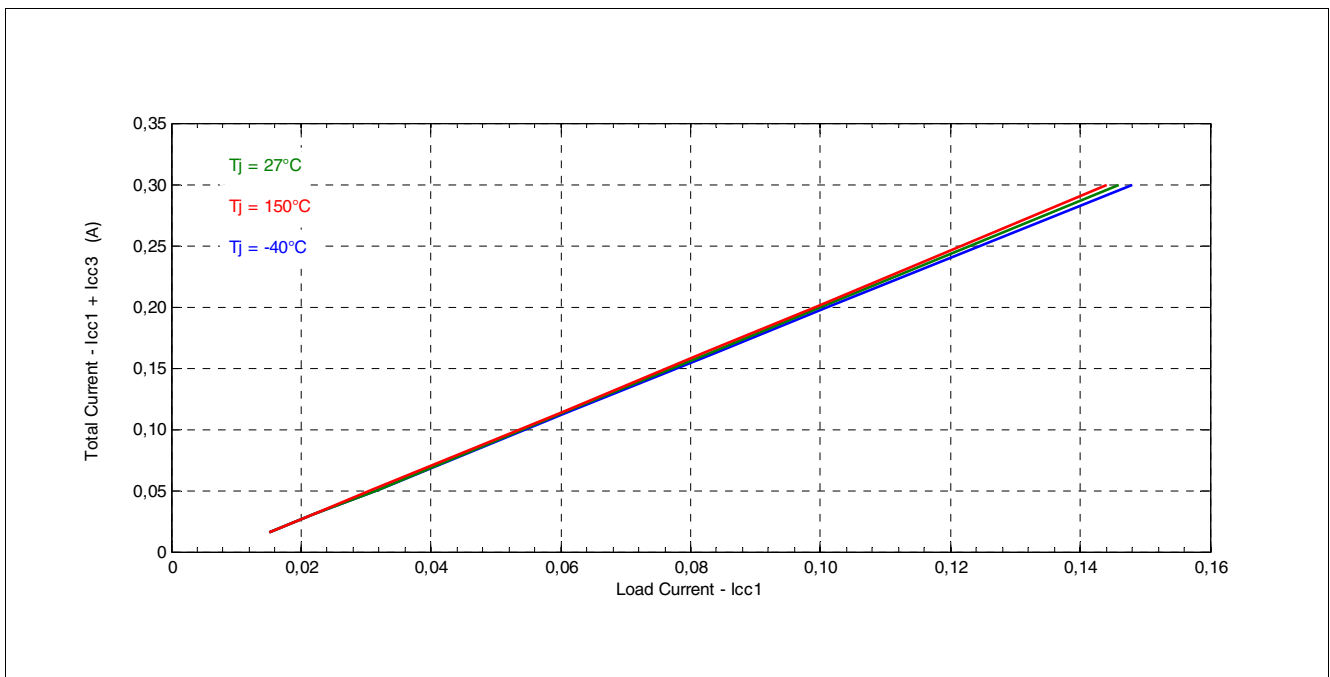
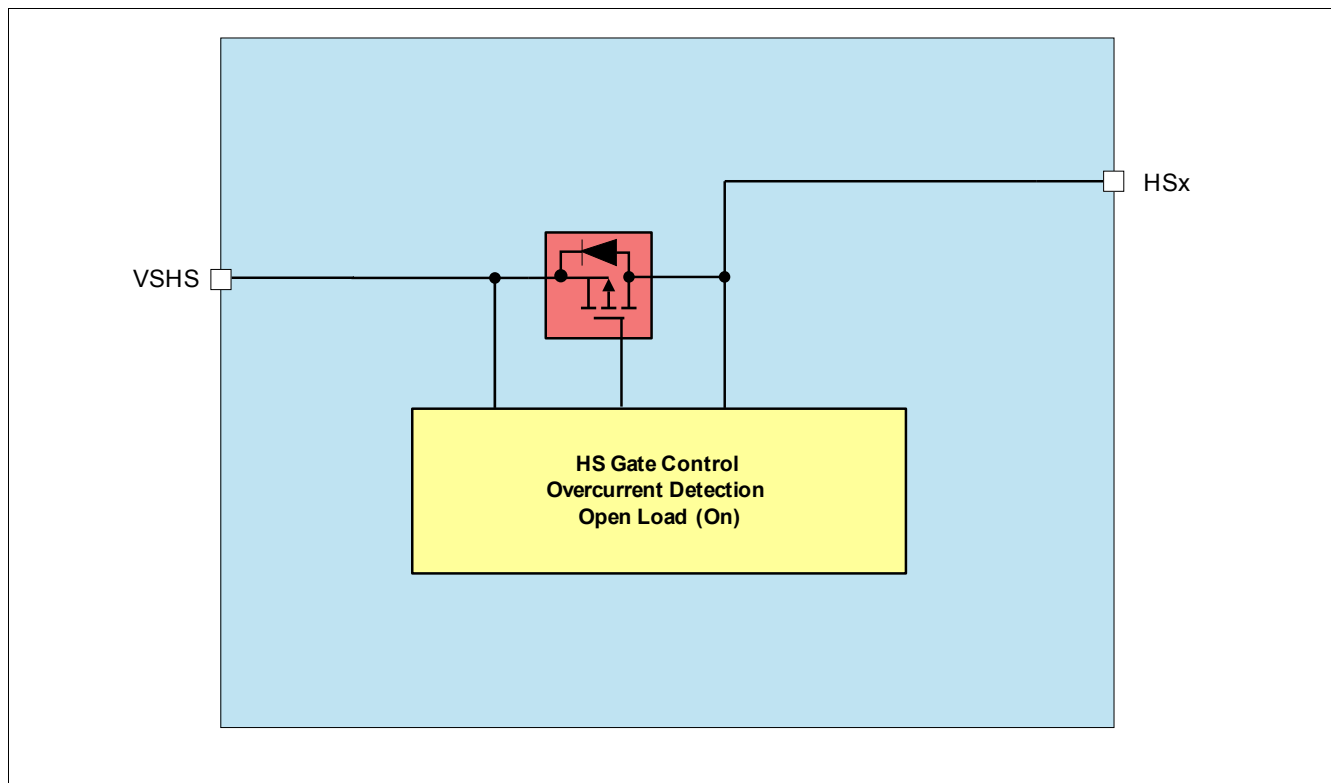


Figure 23 Load Sharing Behavior of ICC1 vs. the total load current

## High-Side Switch

# 9 High-Side Switch

## 9.1 Block Description



**Figure 24 High-Side Module Block Diagram**

### Features

- Dedicated supply pin VSHS for high-side outputs
- Overvoltage and undervoltage switch off - configurable via SPI
- Overcurrent detection and switch off
- Open load detection in ON-state
- PWM capability with internal timer configurable via SPI
- Switch recovery after removal of OV or UV condition configurable via SPI

## 9.2 Functional Description

The High-Side switches can be used for control of LEDs, as supply for the wake inputs and for other loads. The High-Side outputs can be controlled either directly via SPI by ([HS\\_CTRL1](#), [HS\\_CTRL2](#)), by the integrated timers or by the integrated PWM generators.

The high-side outputs are supplied by a dedicated supply pin VSHS (different to VS). The topology supports improved cranking condition behavior.

The configuration of the High-Side (Permanent On, PWM, cyclic sense, etc.) drivers must be done in SBC Normal Mode. The configuration is taken over in SBC Stop- or SBC Sleep Mode and cannot be modified. When entering SBC Restart Mode or SBC Fail-Safe Mode the HSx outputs are disabled.

## High-Side Switch

### 9.2.1 Over- and Undervoltage Switch Off

All HS drivers in on-state are switched off in case of overvoltage on VSHS ( $V_{SHS,OVD}$ ). If the voltage drops below the overvoltage threshold the HS drivers are activated again. The feature can be disabled by setting the SPI bit **HS\_OV\_SD\_EN**.

The HS drivers are switched off in case of undervoltage on VSHS ( $V_{SHS,UVD}$ ). If the voltage rises above the undervoltage threshold the HS drivers are activated again. The feature can be disabled by setting the SPI bit **HS\_UV\_SD\_EN**.

So after release of undervoltage or overvoltage condition the HS switch goes back to programmed state in which it was configured via SPI. This behavior is only valid if the bit **HS\_OV\_UV\_REC** is set to '1'. Otherwise the switches will stay off and the respective SPI control bits are cleared.

The overvoltage and undervoltage is signaled in the bits **VSHS\_OV** and **VSHS\_UV**, no other error bits are set.

### 9.2.2 Overcurrent Detection and Switch Off

If the load current exceeds the overcurrent shutdown threshold for a time longer than the overcurrent shutdown filter time the output is switched off.

The overcurrent condition and the switch off is signaled with the respective HSx\_OC\_OT bit in the register **HS\_OC\_OT\_STAT**. The HSx configuration is then reset to 000 by the SBC. To activate the High-Side again the HSx configuration has to be set to ON (001) or be programmed to a timer function. It is recommended to clear the overcurrent bit before activation the High-Side switch, as the bits are not cleared automatically by the SBC.

### 9.2.3 Open Load Detection

Open load detection on the High-Side outputs is done during on state of the output. If the current in the activated output falls below then Open Load Detection current, the open load is detected and signaled via the respective bit HS1\_OL, HS2\_OL, HS3\_OL, or HS4\_OL in the register **HS\_OL\_STAT**. The High-Side output stays activated. If the open load condition disappears the Open Load bit in the SPI can be cleared. The bits are not cleared automatically by the SBC.

### 9.2.4 HSx Operation in Different SBC Modes

- During SBC Stop and SBC Sleep Mode the HSx outputs can be used for the cyclic sense feature. The open-load detection, overcurrent shut down as well as overvoltage and undervoltage shutdown are available. The overcurrent shutdown protection feature may influence the wake-up behavior<sup>1)</sup>.
- the HSx output can also be enabled for SBC Stop and SBC Sleep Mode as well as controlled by the PWMx generator. The HSx outputs must be configured in SBC Normal Mode before entering a low-power mode.
- The HSx outputs are switched off during SBC Restart or SBC Fail-Safe Mode. They can be enabled via SPI if the failure condition is removed.

1) For the wake feature, the forced overcurrent shut down case must be considered in the user software for all SBC Modes, i.e. due to disabled HSx switches a level change might not be detected anymore at WKx pins.

## High-Side Switch

### 9.2.5 PWM and Timer Function

Two 8-bit PWM generators are dedicated to generate a PWM signal on the HS outputs, e.g. for brightness adjustment or compensation of supply voltage fluctuation. The PWM generators are mapped to the dedicated HS outputs, and the duty cycle can be independently configured with a 8bit resolution via SPI (**PWM1\_CTRL**, **PWM2\_CTRL**). Two different frequencies (200Hz, 400Hz) can be selected independently for every PWM generator in the register **PWM\_FREQ\_CTRL**.

#### **PWM Assignment and Configuration:**

- Configure duty cycle and frequency for respective PWM generator in **PWM1\_CTRL/PWM2\_CTRL** and **PWM\_FREQ\_CTRL**
- Assign PWM generator to respective HS switch(es) in HSx\_CTRL
- The PWM generation will start right after the HSx is assigned to the PWM generator (**HS\_CTRL1**, **HS\_CTRL2**)

#### **Assignment options of HS1... HS4**

- Timer 1
- Timer 2
- PWM 1
- PWM 2

#### **Minimum On-time during PWM Operation**

The min. on-time during PWM is limited by the actual on- and off-time of the respective HS switch, e.g. the PWM setting '0000 0001' could not be realized.

#### **Reliable Open-Load Detection during PWM Operation**

The minimum PWM setting for a reliable open-load detection is 3digits for a period of 400Hz and >2 digits for the frequency setting of 200Hz, i.e. the high-side on-time must be longer than  $t_{OL,HS}$ .

#### **Reliable Overcurrent Detection during PWM Operation**

The minimum PWM setting for a reliable overcurrent detection is >1 digit for a period of 400Hz and 1 digit for the frequency setting of 200Hz, i.e. the high-side on-time must be longer than  $t_{SD,HS}$ .



## High-Side Switch

## 9.3 Electrical Characteristics

**Table 15** Electrical Characteristics

$V_S = 5.5\text{ V to }28\text{ V}$ ;  $T_j = -40\text{ °C to }+150\text{ °C}$ ; all voltages with respect to ground, positive current flowing into pin (unless otherwise specified)

Parameter	Symbol	Values			Unit	Note or Test Condition	Number
		Min.	Typ.	Max.			
<b>Output HS1, HS2, HS3, HS4</b>							
Static Drain-Source ON Resistance HS1...HS4	$R_{ON,HS25}$	–	7	10	$\Omega$	$I_{ds} = 60\text{mA}$ , $T_j < 25\text{°C}$	P_9.3.1
Static Drain-Source ON Resistance HS1...HS4	$R_{ON,HS150}$	–	11.5	16	$\Omega$	$I_{ds} = 60\text{mA}$ , $T_j < 150\text{°C}$	P_9.3.2
Leakage Current HSx / per channel	$I_{leak,HS}$	–	–	2	$\mu\text{A}$	<sup>1)</sup> $0\text{ V} < V_{HSx} < V_{SHS}$ ; $T_j < 85\text{°C}$	P_9.3.11
Output Slew Rate (rising)	$SR_{raise,HS}$	0.8	–	2.5	$\text{V}/\mu\text{s}$	<sup>1)</sup> 20 to 80% $V_{SHS} = 6\text{ to }18\text{V}$ $R_L = 220\Omega$	P_9.3.3
Output Slew Rate (falling)	$SR_{fall,HS}$	-2.5	–	-0.8	$\text{V}/\mu\text{s}$	<sup>1)</sup> 80 to 20% $V_{SHS} = 6\text{ to }18\text{V}$ $R_L = 220\Omega$	P_9.3.4
Switch-on time HSx	$t_{ON,HS}$	3	–	30	$\mu\text{s}$	CSN = HIGH to $0.8 \cdot V_{SHS}$ ; $R_L = 220\Omega$ ; $V_{SHS} = 6\text{ to }18\text{V}$	P_9.3.5
Switch-off time HSx	$t_{OFF,HS}$	3	–	30	$\mu\text{s}$	CSN = HIGH to $0.2 \cdot V_{SHS}$ ; $R_L = 220\Omega$ ; $V_{SHS} = 6\text{ to }18\text{V}$	P_9.3.6
Short Circuit Shutdown Current	$I_{SD,HS}$	150	245	300	$\text{mA}$	$V_{SHS} = 6\text{ to }20\text{V}$ , hysteresis included	P_9.3.7
Short Circuit Shutdown Filter Time	$t_{SD,HS}$	12	16	20	$\mu\text{s}$	<sup>2), 3)</sup>	P_9.3.8
Open Load Detection Current	$I_{OL,HS}$	0.4	–	3	$\text{mA}$	hysteresis included	P_9.3.9
Open Load Detection hysteresis	$I_{OL,HS,hys}$	0.05	0.45	1.0	$\text{mA}$	<sup>1)</sup>	P_9.3.14
Open Load Detection Filter Time	$t_{OL,HS}$	50	64	80	$\mu\text{s}$	<sup>2), 3)</sup>	P_9.3.10

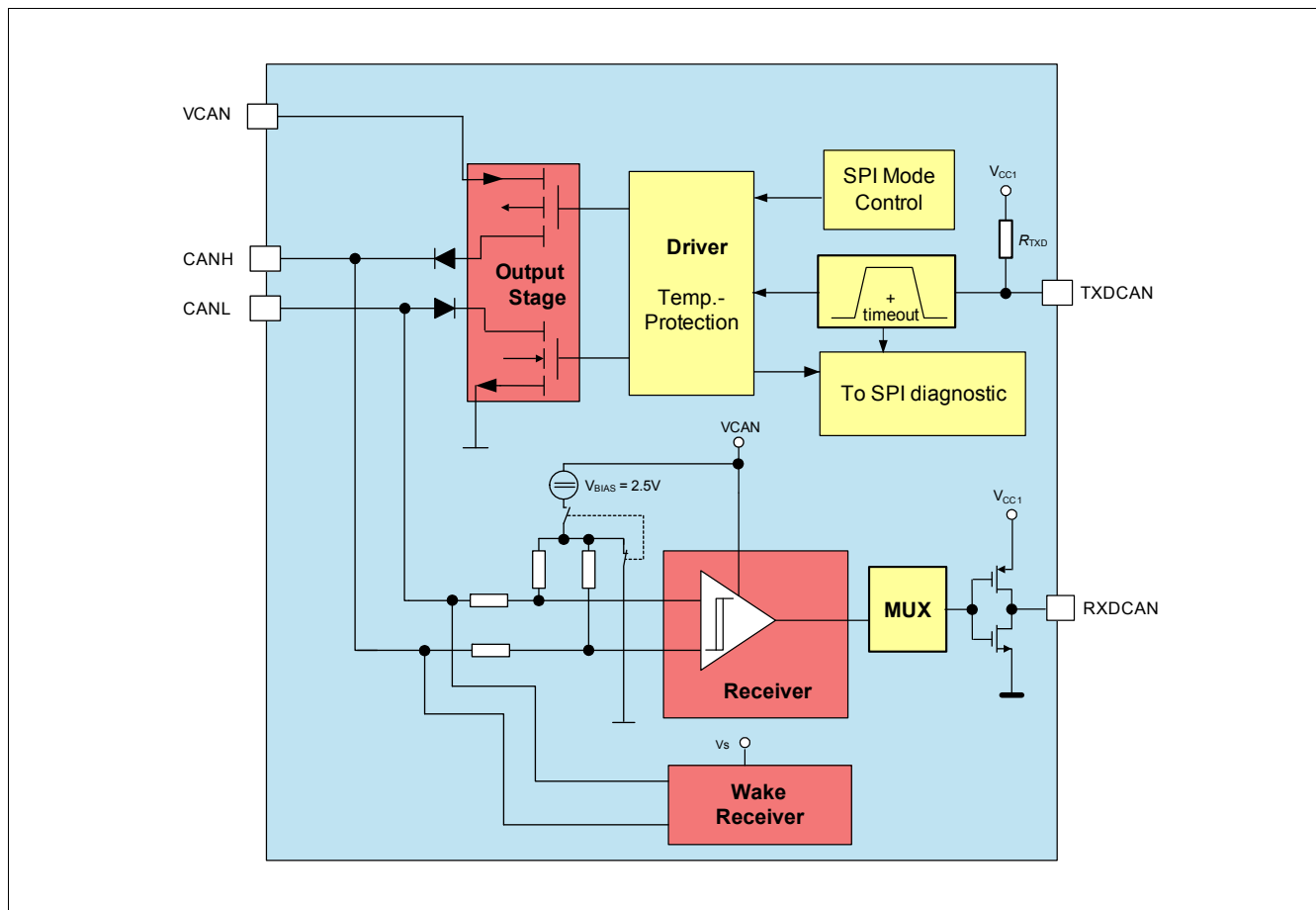
1) Not subject to production test, specified by design.

2) Not subject to production test, tolerance defined by internal oscillator tolerance.

3) Configure proper minimum PWM settings for reliable detection of overcurrent and open load measurement (see also [Chapter 9.2.5](#)).

## 10 High Speed CAN Transceiver

### 10.1 Block Description



**Figure 25 Functional Block Diagram**

### 10.2 Functional Description

The Controller Area Network (CAN) transceiver part of the SBC provides high-speed (HS) differential mode data transmission (up to 2 Mbaud) and reception in automotive and industrial applications. It works as an interface between the CAN protocol controller and the physical bus lines compatible to ISO 11898-2:2016 and SAE J2284.

The CAN transceiver offers low power modes to reduce current consumption. This supports networks with partially powered down nodes. To support software diagnostic functions, a CAN Receive-only Mode is implemented.

It is designed to provide excellent passive behavior when the transceiver is switched off (mixed networks, clamp15/30 applications).

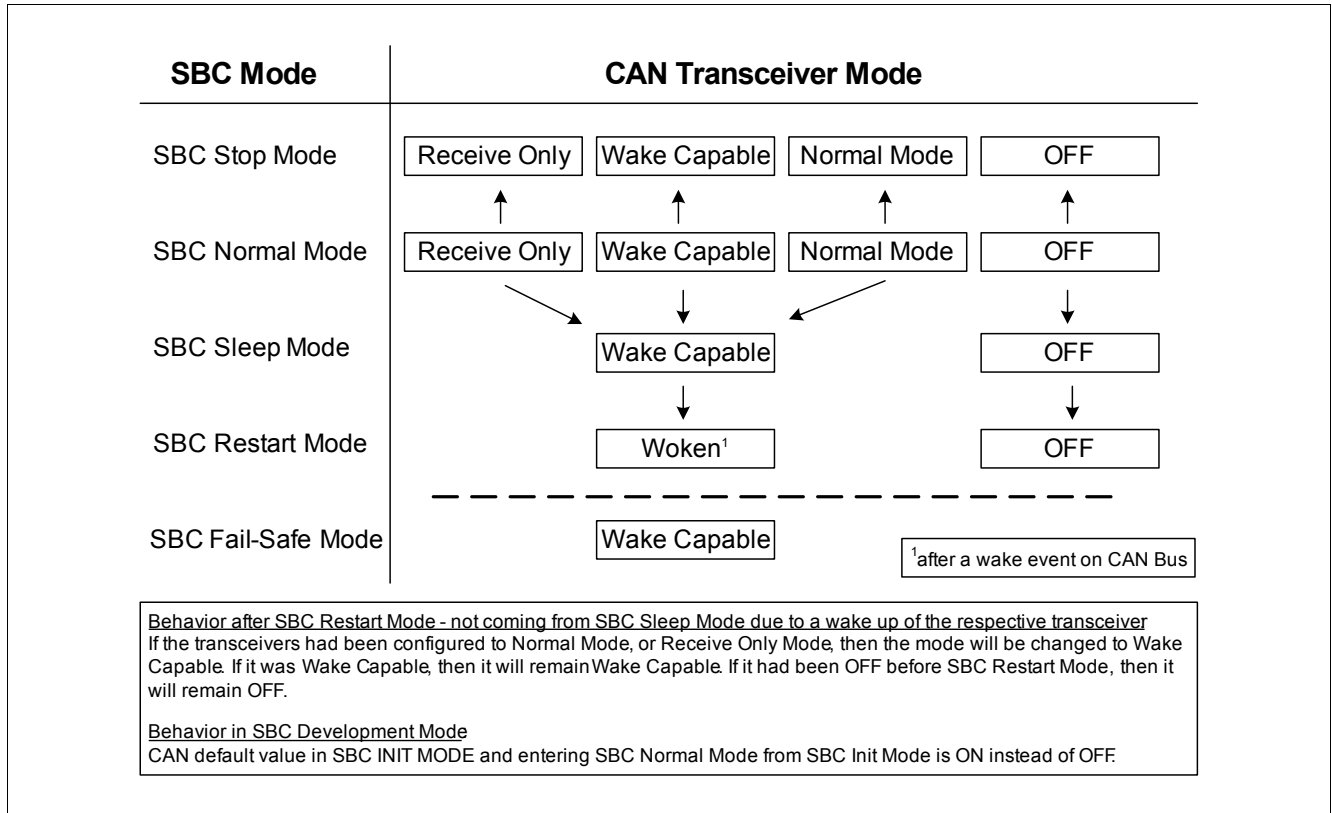
A wake-up from the CAN wake capable mode is possible via a message on the bus. Thus, the microcontroller can be powered down or idled and will be woken up by the CAN bus activities.

The CAN transceiver is designed to withstand the severe conditions of automotive applications and to support 12 V applications.

**High Speed CAN Transceiver**

The different transceiver modes can be controlled via the SPI CAN bits.

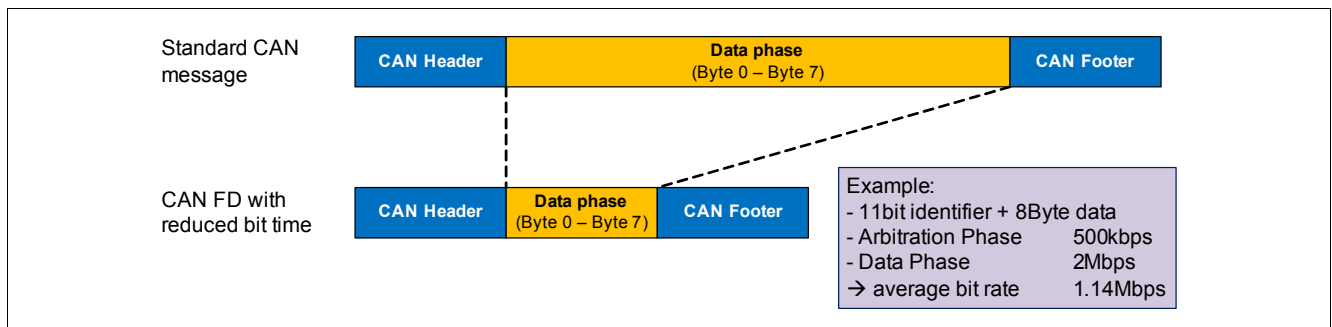
**Figure 26** shows the possible transceiver mode transitions when changing the SBC mode.



**Figure 26 CAN Mode Control Diagram**

**CAN FD Support**

CAN FD stands for ‘CAN with Flexible Data Rate’. It is based on the well established CAN protocol as specified in ISO 11898-1. CAN FD still uses the CAN bus arbitration method. The benefit is that the bit rate can be increased by switching to a shorter bit time at the end of the arbitration process and then to return to the longer bit time at the CRC delimiter, before the receivers transmit their acknowledged bits. See also **Figure 27**. In addition, the effective data rate is increased by allowing longer data fields. CAN FD allows the transmission of up to 64 data bytes compared to the 8 data bytes from the standard CAN.



**Figure 27 Bite Rate Increase with CAN FD vs. Standard CAN**

Not only the physical layer must support CAN FD but also the CAN controller. In case the CAN controller is not able to support CAN FD then the respective CAN node must at least tolerate CAN FD communication. This CAN

## High Speed CAN Transceiver

FD tolerant mode is realized in the physical layer in combination with CAN Partial Networking. The TLE926x-3QX variants of this family also support the CAN FD tolerant mode.

### 10.2.1 CAN OFF Mode

The CAN OFF Mode is the default mode after power-up of the SBC. It is available in all SBC Modes and is intended to completely stop CAN activities or when CAN communication is not needed. The CANH/L bus interface acts as a high impedance input with a very small leakage current. In CAN OFF Mode, a wake-up event on the bus will be ignored.

### 10.2.2 CAN Normal Mode

The CAN Transceiver is enabled via SPI in SBC Normal Mode. CAN Normal Mode is designed for normal data transmission/reception within the HS-CAN network. The Mode is available in SBC Normal Mode and in SBC Stop Mode. The bus biasing is set to  $V_{CAN}/2$ .

### Transmission

The signal from the microcontroller is applied to the TXDCAN input of the SBC. The bus driver switches the CANH/L output stages to transfer this input signal to the CAN bus lines.

### Enabling sequence

The CAN transceiver requires an enabling time  $t_{CAN,EN}$  before a message can be sent on the bus. This means that the TXDCAN signal can only be pulled LOW after the enabling time. If this is not ensured, then the TXDCAN needs to be set back to HIGH (=recessive) until the enabling time is completed.

Only the next dominant bit will be transmitted on the bus.

Figure 28 shows different scenarios and explanations for CAN enabling.

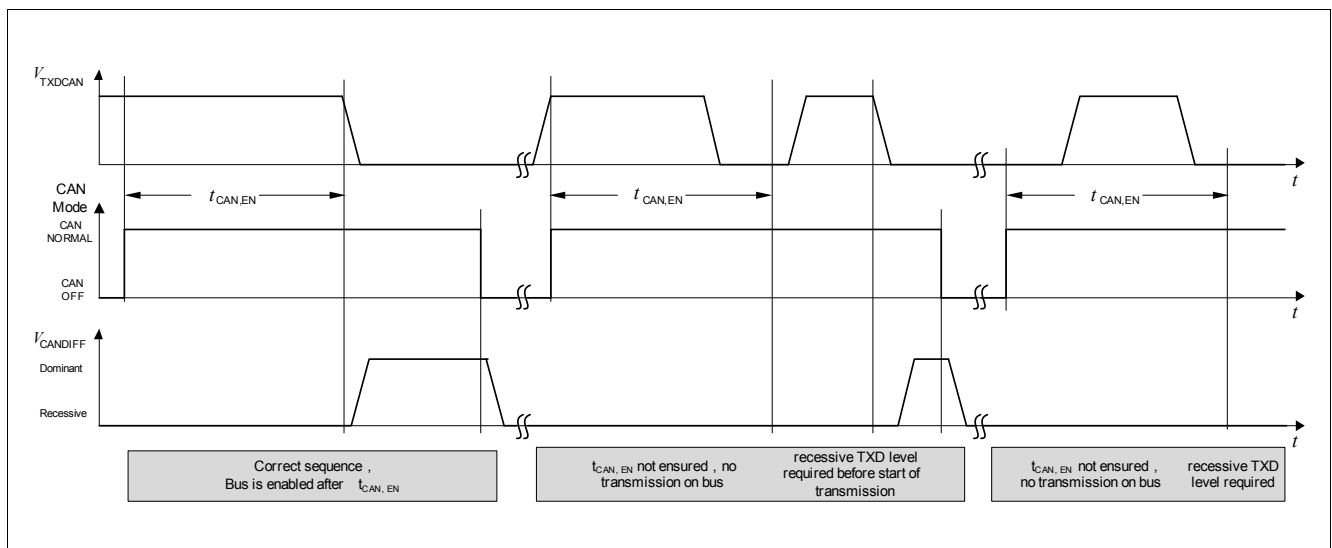


Figure 28 CAN Transceiver Enabling Sequence

### Reduced Electromagnetic Emission

To reduce electromagnetic emissions (EME), the bus driver controls CANH/L slopes symmetrically.

### Reception

Analog CAN bus signals are converted into digital signals at RXD via the differential input receiver.

---

## High Speed CAN Transceiver

### 10.2.3 CAN Receive Only Mode

In CAN Receive Only Mode (RXD only), the driver stage is de-activated but reception is still operational. This mode is accessible by an SPI command in Normal Mode and in Stop Mode. The bus biasing is set to VCAN/2.

### 10.2.4 CAN Wake Capable Mode

This mode can be used in SBC Stop, Sleep, Restart and Normal Mode and it is used to monitor bus activities. It is automatically accessed in SBC Fail-Safe Mode. Both bus pins CANH/L are connected to GND via the input resistors.

A wake-up signal on the bus results in a change of behavior of the SBC, as described in [Table 16](#). The pins CANH/L are terminated to typ. 2.5V through the input resistors. As a wake-up signalization to the microcontroller, the RXD\_CAN pin is set LOW and will stay LOW until the CAN transceiver is changed to any other mode. After a wake-up event, the transceiver can be switched to CAN Normal Mode for communication via SPI.

As shown in [Figure 29](#), a wake-up pattern (WUP) is signaled on the bus by two consecutive dominant bus levels for at least  $t_{Wake1}$  (filter time  $t > t_{Wake1}$ ) and shorter than  $t_{Wake2}$ , each separated by a recessive bus level of greater than  $t_{Wake1}$  and shorter than  $t_{Wake2}$ .

## High Speed CAN Transceiver

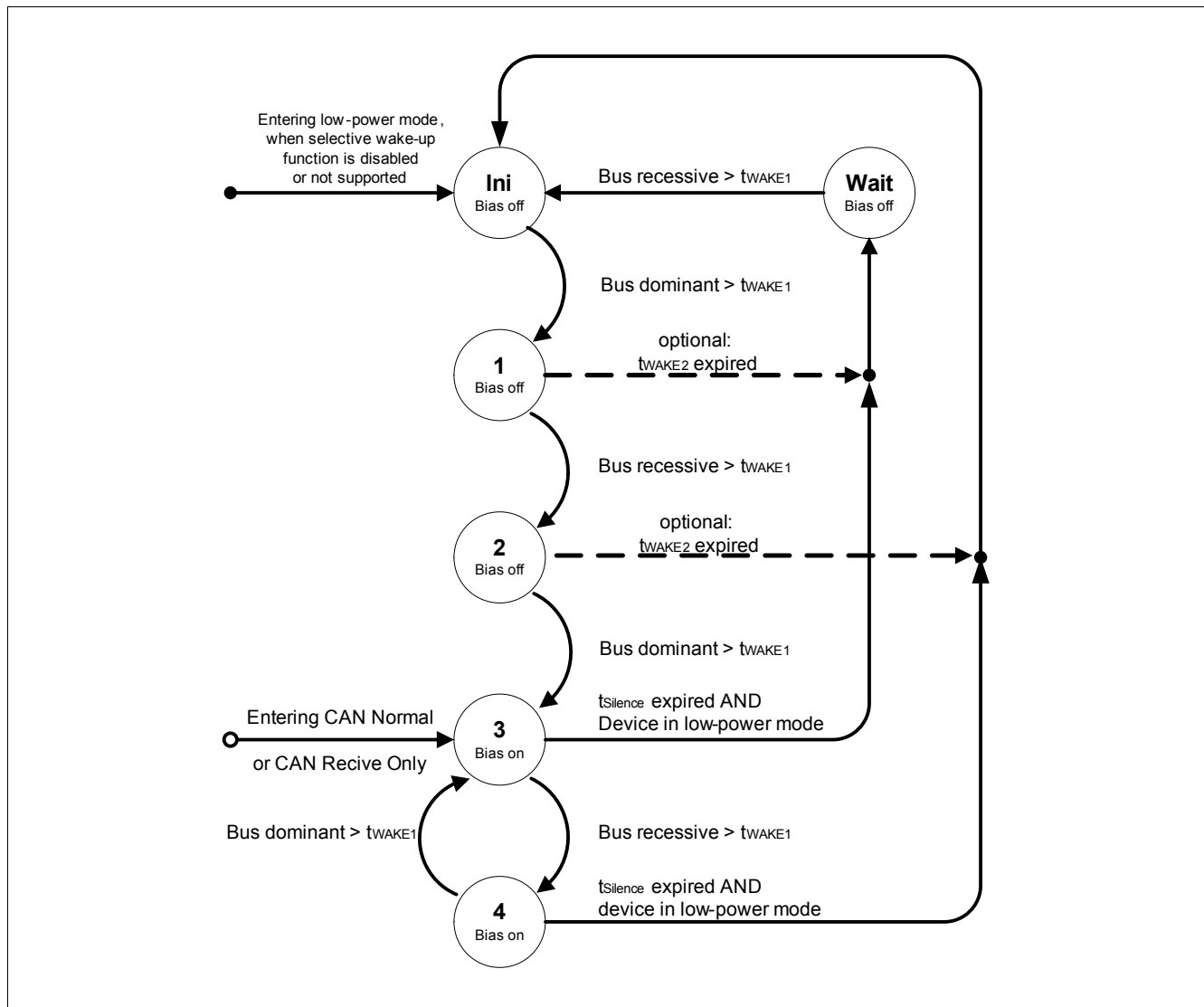


Figure 29 WUP detection following the definition in ISO 11898-2:2016

### Rearming the Transceiver for Wake Capability

After a BUS wake-up event, the transceiver is woken. However, the CAN transceiver mode bits will still show wake capable (=‘01’) so that the RXD signal will be pulled low. There are two possibilities how the CAN transceiver’s wake capable mode is enabled again after a wake event:

- The CAN transceiver mode must be toggled, i.e. switched from Wake Capable Mode to CAN Normal Mode, CAN Receive Only Mode or CAN Off, before switching to CAN Wake Capable Mode again.
- Rearming is done automatically when the SBC is changed to SBC Stop, SBC Sleep, or SBC Fail-Safe Mode to ensure wake-up capability.

Note: It is not necessary to clear the CAN wake-up bit **CAN\_WU** to become wake capable again. It is sufficient to toggle the CAN mode.

Note: The CAN module is supplied by an internal voltage when in CAN Wake Capable Mode, i.e. the module must not be supplied through the VCAN pin during this time. Before changing the CAN Mode to Normal Mode, the supply of VCAN has to be activated first.

## High Speed CAN Transceiver

### Wake-Up in SBC Stop and Normal Mode

In SBC Stop Mode, if a wake-up is detected, it is always signaled by the INT output and in the **WK\_STAT\_1** SPI register. It is also signaled by RXDCAN pulled to low. The same applies for the SBC Normal Mode. The microcontroller should set the device from SBC Stop Mode to SBC Normal Mode, there is no automatic transition to Normal Mode.

For functional safety reasons, the watchdog will be automatically enabled in SBC Stop Mode after a Bus wake event in case it was disabled before (if bit **WD\_EN\_WK\_BUS** was configured to HIGH before).

### Wake-Up in SBC Sleep Mode

Wake-up is possible via a CAN message (filter time  $t > t_{Wake1}$ ). The wake-up automatically transfers the SBC into the SBC Restart Mode and from there to Normal Mode the corresponding RXD pin is set to LOW. The microcontroller is able to detect the low signal on RXD and to read the wake source out of the **WK\_STAT\_1** register via SPI. No interrupt is generated when coming out of Sleep Mode. The microcontroller can now for example switch the CAN transceiver into CAN Normal Mode via SPI to start communication.

**Table 16 Action due to CAN Bus Wake-Up**

SBC Mode	SBC Mode after Wake	VCC1	INT	RXD
Normal Mode	Normal Mode	ON	LOW	LOW
Stop Mode	Stop Mode	ON	LOW	LOW
Sleep Mode	Restart Mode	Ramping Up	HIGH	LOW
Restart Mode	Restart Mode	ON	HIGH	LOW
Fail-Safe Mode	Restart Mode	Ramping up	HIGH	LOW

---

## High Speed CAN Transceiver

### 10.2.5 TXD Time-out Feature

If the TXD signal is dominant for a time  $t > t_{\text{TXD\_CAN\_TO}}$ , in CAN Normal Mode, the TXD time-out function deactivates the transmission of the signal at the bus. This is implemented to prevent the bus from being blocked permanently due to an error. The transmitter is disabled and the transceiver is switched to Receive Only Mode. The failure is stored in the SPI flag **CAN\_FAIL**. The CAN transmitter stage is activated again after the dominant time-out condition is removed and the transceiver is automatically switched back to CAN Normal Mode. The transceiver configuration stays unchanged.

### 10.2.6 Bus Dominant Clamping

If the HS CAN bus signal is dominant for a time  $t > t_{\text{BUS\_CAN\_TO}}$  in CAN Normal and Receive Only Mode a bus dominant clamping is detected and the SPI bit **CAN\_FAIL** is set. The transceiver configuration stays unchanged.

### 10.2.7 Undervoltage Detection

The voltage at the CAN supply pin is monitored only in CAN Normal and Receive Only Mode for SBC Normal and Stop Mode. In case of VCAN undervoltage a signalization via SPI bit **VCAN\_UV** is triggered and the SBC disables the transmitter stage. If the CAN supply reaches a higher level than the undervoltage detection threshold ( $V_{\text{CAN}} > V_{\text{CAN\_UV}}$ ), the transceiver is automatically switched back to CAN Normal Mode. The transceiver configuration stays unchanged.



## High Speed CAN Transceiver

## 10.3 Electrical Characteristics

Table 17 Electrical Characteristics

$V_S = 5.5 \text{ V to } 28 \text{ V}$ ;  $T_j = -40 \text{ }^\circ\text{C to } +150 \text{ }^\circ\text{C}$ ;  $4.75 \text{ V} < V_{\text{CAN}} < 5.25 \text{ V}$ ;  $R_L = 60\Omega$ ; CAN Normal Mode; all voltages with respect to ground, positive current flowing into pin (unless otherwise specified)

Parameter	Symbol	Values			Unit	Note or Test Condition	Number
		Min.	Typ.	Max.			
<b>CAN Bus Receiver</b>							
Differential Receiver Threshold Voltage, recessive to dominant edge	$V_{\text{diff,rd}_N}$	–	0.80	0.90	V	$V_{\text{diff}} = V_{\text{CANH}} - V_{\text{CANL}}$ ; $-12\text{V} \leq V_{\text{CM}}(\text{CAN}) \leq +12\text{V}$ ; $0.9\text{V} \leq V_{\text{diff,D\_Range}} \leq 8\text{V}$ ; CAN Normal Mode	P_10.3.2
Differential Receiver Threshold Voltage, dominant to recessive edge	$V_{\text{diff,dr}_N}$	0.50	0.60	–	V	$V_{\text{diff}} = V_{\text{CANH}} - V_{\text{CANL}}$ ; $-12\text{V} \leq V_{\text{CM}}(\text{CAN}) \leq +12\text{V}$ ; $-3\text{V} \leq V_{\text{diff,R\_Range}} \leq 0.5\text{V}$ ; CAN Normal Mode	P_10.3.3
Common Mode Range	CMR	-12	–	12	V	<sup>1)</sup>	P_10.3.4
CANH, CANL Input Resistance	$R_{\text{in}}$	20	40	50	k $\Omega$	CAN Normal / Wake capable Mode; Recessive state; $-2\text{V} \leq V_{\text{CANL/H}} \leq +7\text{V}$	P_10.3.6
Differential Input Resistance	$R_{\text{diff}}$	40	80	100	k $\Omega$	CAN Normal / Wake capable Mode; Recessive state; $-2\text{V} \leq V_{\text{CANL/H}} \leq +7\text{V}$	P_10.3.7
Input Resistance Deviation between CANH and CANL	$\Delta R_i$	-3	–	3	%	<sup>1)</sup> Recessive state; $V_{\text{CANH}} = V_{\text{CANL}} = 5\text{V}$	P_10.3.38
Input Capacitance CANH, CANL versus GND	$C_{\text{in}}$	–	20	40	pF	<sup>1)</sup> $V_{\text{TXD}} = 5\text{V}$	P_10.3.39
Differential Input Capacitance	$C_{\text{diff}}$	–	10	20	pF	<sup>1)</sup> $V_{\text{TXD}} = 5\text{V}$	P_10.3.40
Wake-up Receiver Threshold Voltage, recessive to dominant edge	$V_{\text{diff,rd}_W}$	–	0.8	1.15	V	$-12\text{V} \leq V_{\text{CM}}(\text{CAN}) \leq +12\text{V}$ ; $1.15\text{V} \leq V_{\text{diff,D\_Range}} \leq 8\text{V}$ ; CAN Wake Capable Mode	P_10.3.8
Wake-up Receiver Threshold Voltage, dominant to recessive edge	$V_{\text{diff,dr}_W}$	0.4	0.7	–	V	$-12\text{V} \leq V_{\text{CM}}(\text{CAN}) \leq +12\text{V}$ ; $-3\text{V} \leq V_{\text{diff,R\_Range}} \leq 0.4\text{V}$ ; CAN Wake Capable Mode	P_10.3.9
<b>CAN Bus Transmitter</b>							
CANH/CANL Recessive Output Voltage (CAN Normal Mode)	$V_{\text{CANL/H\_NM}}$	2.0	–	3.0	V	CAN Normal Mode; $V_{\text{TXD}} = V_{\text{CC1}}$ ; no load	P_10.3.11

## High Speed CAN Transceiver

**Table 17 Electrical Characteristics** (cont'd)

$V_S = 5.5 \text{ V to } 28 \text{ V}$ ;  $T_j = -40 \text{ }^\circ\text{C to } +150 \text{ }^\circ\text{C}$ ;  $4.75 \text{ V} < V_{\text{CAN}} < 5.25 \text{ V}$ ;  $R_L = 60\Omega$ ; CAN Normal Mode; all voltages with respect to ground, positive current flowing into pin (unless otherwise specified)

Parameter	Symbol	Values			Unit	Note or Test Condition	Number
		Min.	Typ.	Max.			
CANH/CANL Recessive Output Voltage (CAN Wake Capable Mode)	$V_{\text{CANL/H\_LP}}$	-0.1	-	0.1	V	CAN Wake Capable Mode; $V_{\text{TXD}} = V_{\text{CC1}}$ ; no load	P_10.3.43
CANH, CANL Recessive Output Voltage Difference $V_{\text{diff}} = V_{\text{CANH}} - V_{\text{CANL}}$ (CAN Normal Mode)	$V_{\text{diff\_r\_N}}$	-500	-	50	mV	CAN Normal Mode $V_{\text{TXD}} = V_{\text{CC1}}$ ; no load	P_10.3.12
CANH, CANL Recessive Output Voltage Difference $V_{\text{diff}} = V_{\text{CANH}} - V_{\text{CANL}}$ (CAN Wake Capable Mode)	$V_{\text{diff\_r\_W}}$	-200	-	200	mV	CAN Wake Capable Mode; $V_{\text{TXD}} = V_{\text{CC1}}$ ; no load	P_10.3.41
CANL Dominant Output Voltage	$V_{\text{CANL}}$	0.5	-	2.25	V	CAN Normal Mode; $V_{\text{TXD}} = 0 \text{ V}$ ; $V_{\text{CAN}} = 5 \text{ V}$ ; $50\Omega \leq R_L \leq 65\Omega$	P_10.3.13
CANH Dominant Output Voltage	$V_{\text{CANH}}$	2.75	-	4.5	V	CAN Normal Mode; $V_{\text{TXD}} = 0 \text{ V}$ ; $V_{\text{CAN}} = 5 \text{ V}$ ; $50\Omega \leq R_L \leq 65\Omega$	P_10.3.14
CANH, CANL Dominant Output Voltage Difference $V_{\text{diff}} = V_{\text{CANH}} - V_{\text{CANL}}$	$V_{\text{diff\_d\_N}}$	1.5	-	3.0	V	CAN Normal Mode; $V_{\text{TXD}} = 0 \text{ V}$ ; $V_{\text{CAN}} = 5 \text{ V}$ ; $50\Omega \leq R_L \leq 65\Omega$	P_10.3.16
CANH, CANL Dominant Output Voltage Difference $V_{\text{diff}} = V_{\text{CANH}} - V_{\text{CANL}}$	$V_{\text{diff\_d\_N}}$	1.5	-	5.0	V	<sup>1)</sup> CAN Normal Mode; $V_{\text{TXD}} = 0 \text{ V}$ ; $V_{\text{CAN}} = 5 \text{ V}$ ; $R_L = 2240\Omega$	P_10.3.55
CANH, CANL Dominant Output Voltage Difference $V_{\text{diff}} = V_{\text{CANH}} - V_{\text{CANL}}$	$V_{\text{diff\_d\_N}}$	1.4	-	3.3	V	<sup>1)</sup> CAN Normal Mode; $V_{\text{TXD}} = 0 \text{ V}$ ; $V_{\text{CAN}} = 5 \text{ V}$ ; $45\Omega \leq R_L \leq 70\Omega$	P_10.3.56
Driver Symmetry $V_{\text{SYM}} = V_{\text{CANH}} + V_{\text{CANL}}$	$V_{\text{SYM}}$	4.5	-	5.5	V	<sup>2)</sup> CAN Normal Mode; $V_{\text{TXD}} = 0 \text{ V} / 5 \text{ V}$ ; $V_{\text{CAN}} = 5 \text{ V}$ ; $C_{\text{SPLIT}} = 4.7\text{nF}$ ; $R_L = 60\Omega$ ;	P_10.3.42
CANH Short Circuit Current	$I_{\text{CANHsc}}$	-115	-80	-50	mA	CAN Normal Mode; $V_{\text{CANHshort}} = -3 \text{ V}$	P_10.3.17

## High Speed CAN Transceiver

**Table 17 Electrical Characteristics (cont'd)**

$V_S = 5.5 \text{ V to } 28 \text{ V}$ ;  $T_j = -40 \text{ }^\circ\text{C to } +150 \text{ }^\circ\text{C}$ ;  $4.75 \text{ V} < V_{\text{CAN}} < 5.25 \text{ V}$ ;  $R_L = 60\Omega$ ; CAN Normal Mode; all voltages with respect to ground, positive current flowing into pin (unless otherwise specified)

Parameter	Symbol	Values			Unit	Note or Test Condition	Number
		Min.	Typ.	Max.			
CANL Short Circuit Current	$I_{\text{CANLsc}}$	50	80	115	mA	CAN Normal Mode $V_{\text{CANLshort}} = 18 \text{ V}$	P_10.3.18
Leakage Current (unpowered device)	$I_{\text{CANH,Ik}}$ $I_{\text{CANL,Ik}}$	–	5	7.5	$\mu\text{A}$	$V_S = V_{\text{CAN}} = 0\text{V}$ ; $0\text{V} < V_{\text{CANH,L}} \leq 5\text{V}$ ; <sup>3)</sup> $R_{\text{test}} = 0 / 47 \text{ k}\Omega$	P_10.3.19

### Receiver Output RXD

HIGH level Output Voltage	$V_{\text{RXD,H}}$	$0.8 \times V_{\text{CC1}}$	–	–	V	CAN Normal Mode $I_{\text{RXD(CAN)}} = -2 \text{ mA}$ ;	P_10.3.21
LOW Level Output Voltage	$V_{\text{RXD,L}}$	–	–	$0.2 \times V_{\text{CC1}}$	V	CAN Normal Mode $I_{\text{RXD(CAN)}} = 2 \text{ mA}$ ;	P_10.3.22

### Transmission Input TXD

HIGH Level Input Voltage Threshold	$V_{\text{TXD,H}}$	–	–	$0.7 \times V_{\text{CC1}}$	V	CAN Normal Mode recessive state	P_10.3.23
LOW Level Input Voltage Threshold	$V_{\text{TXD,L}}$	$0.3 \times V_{\text{CC1}}$	–	–	V	CAN Normal Mode dominant state	P_10.3.24
TXD Input Hysteresis	$V_{\text{TXD,hys}}$	$0.08 \times V_{\text{CC1}}$	$0.12 \times V_{\text{CC1}}$	$0.5 \times V_{\text{CC1}}$	V	<sup>1)</sup>	P_10.3.25
TXD Pull-up Resistance	$R_{\text{TXD}}$	20	40	80	k $\Omega$	–	P_10.3.26
CAN Transceiver Enabling Time	$t_{\text{CAN,EN}}$	8	13	18	$\mu\text{s}$	<sup>4)</sup> CSN = HIGH to first valid transmitted TXD dominant	P_10.3.27

### Dynamic CAN-Transceiver Characteristics

Min. Dominant Time for Bus Wake-up	$t_{\text{Wake1}}$	0.50	–	1.8	$\mu\text{s}$	$-12\text{V} \leq V_{\text{CM(CAN)}} \leq +12\text{V}$ ; CAN Wake capable Mode	P_10.3.28
Wake-up Time-out, Recessive Bus	$t_{\text{Wake2}}$	0.8	–	10	ms	<sup>4)</sup> CAN Wake capable Mode	P_10.3.29
WUP Wake-up Reaction Time	$t_{\text{WU,WUP}}$	–	–	100	$\mu\text{s}$	<sup>4)5)6)</sup> Wake-up reaction time after a valid WUP on CAN bus;	P_10.3.44
Loop delay (recessive to dominant)	$t_{\text{LOOP,f}}$	–	150	255	ns	<sup>2)</sup> CAN Normal Mode $C_L = 100 \text{ pF}$ ; $R_L = 60 \Omega$ ; $V_{\text{CAN}} = 5 \text{ V}$ ; $C_{\text{RXD}} = 15 \text{ pF}$	P_10.3.30

## High Speed CAN Transceiver

**Table 17 Electrical Characteristics** (cont'd)

$V_S = 5.5 \text{ V to } 28 \text{ V}$ ;  $T_j = -40 \text{ }^\circ\text{C to } +150 \text{ }^\circ\text{C}$ ;  $4.75 \text{ V} < V_{\text{CAN}} < 5.25 \text{ V}$ ;  $R_L = 60\Omega$ ; CAN Normal Mode; all voltages with respect to ground, positive current flowing into pin  
(unless otherwise specified)

Parameter	Symbol	Values			Unit	Note or Test Condition	Number
		Min.	Typ.	Max.			
Loop delay (dominant to recessive)	$t_{\text{LOOP},r}$	–	150	255	ns	<sup>2)</sup> CAN Normal Mode $C_L = 100 \text{ pF}$ ; $R_L = 60 \Omega$ ; $V_{\text{CAN}} = 5 \text{ V}$ ; $C_{\text{RXD}} = 15 \text{ pF}$	P_10.3.31
Propagation Delay TXD LOW to bus dominant	$t_{d(L),T}$	–	50	–	ns	CAN Normal Mode $C_L = 100\text{pF}$ ; $50\Omega \leq R_L \leq 65\Omega$ ; $V_{\text{CAN}} = 5 \text{ V}$ ;	P_10.3.32
Propagation Delay TXD HIGH to bus recessive	$t_{d(H),T}$	–	50	–	ns	CAN Normal Mode $C_L = 100 \text{ pF}$ ; $50\Omega \leq R_L \leq 65\Omega$ ; $V_{\text{CAN}} = 5 \text{ V}$ ;	P_10.3.33
Propagation Delay bus dominant to RXD LOW	$t_{d(L),R}$	–	100	–	ns	CAN Normal Mode $C_L = 100\text{pF}$ ; $50\Omega \leq R_L \leq 60\Omega$ ; $V_{\text{CAN}} = 5 \text{ V}$ ; $C_{\text{RXD}} = 15 \text{ pF}$	P_10.3.34
Propagation Delay bus recessive to RXD HIGH	$t_{d(H),R}$	–	100	–	ns	CAN Normal Mode $C_L = 100\text{pF}$ ; $50\Omega \leq R_L \leq 60\Omega$ ; $V_{\text{CAN}} = 5 \text{ V}$ ; $C_{\text{RXD}} = 15 \text{ pF}$	P_10.3.35
Received Recessive Bit Width (CAN FD up to 2Mbps)	$t_{\text{bit(RXD)}}$	400	–	550	ns	CAN Normal Mode $C_L = 100\text{pF}$ ; $R_L = 60 \Omega$ ; $V_{\text{CAN}} = 5 \text{ V}$ ; $C_{\text{RXD}} = 15 \text{ pF}$ ; $t_{\text{bit(TXD)}} = 500\text{ns}$ ; Timing definition according to <a href="#">Figure 31</a>	P_10.3.46
Transmitted Recessive Bit Width (CAN FD up to 2Mbps)	$t_{\text{bit(BUS)}}$	435	–	530	ns	CAN Normal Mode $C_L = 100\text{pF}$ ; $R_L = 60 \Omega$ ; $V_{\text{CAN}} = 5 \text{ V}$ ; $C_{\text{RXD}} = 15 \text{ pF}$ ; $t_{\text{bit(TXD)}} = 500\text{ns}$ ;Timing definition according to <a href="#">Figure 31</a>	P_10.3.47

## High Speed CAN Transceiver

**Table 17 Electrical Characteristics** (cont'd)

$V_S = 5.5 \text{ V to } 28 \text{ V}$ ;  $T_j = -40 \text{ }^\circ\text{C to } +150 \text{ }^\circ\text{C}$ ;  $4.75 \text{ V} < V_{\text{CAN}} < 5.25 \text{ V}$ ;  $R_L = 60\Omega$ ; CAN Normal Mode; all voltages with respect to ground, positive current flowing into pin (unless otherwise specified)

Parameter	Symbol	Values			Unit	Note or Test Condition	Number
		Min.	Typ.	Max.			
Receiver Timing Symmetry (CAN FD up to 2Mbps)	$\Delta t_{\text{Rec}}$	-65	-	40	ns	CAN Normal Mode $C_L = 100\text{pF}$ ; $R_L = 60 \Omega$ ; $V_{\text{CAN}} = 5 \text{ V}$ ; $C_{\text{RXD}} = 15 \text{ pF}$ ; $t_{\text{bit(TXD)}} = 500\text{ns}$ ; Timing definition according to <a href="#">Figure 31</a>	P_10.3.48
Received Recessive Bit Width (CAN FD up to 5 Mbps)	$t_{\text{bit(RXD)}}$	120	-	220	ns	CAN Normal Mode; $C_L = 100\text{pF}$ ; $R_L = 60 \Omega$ ; $V_{\text{CAN}} = 5 \text{ V}$ ; $C_{\text{RXD}} = 15 \text{ pF}$ ; $t_{\text{bit(TXD)}} = 200 \text{ ns}$ ; Parameter definition in according to <a href="#">Figure 31</a> .	P_10.3.52
Transmitted Recessive Bit Width (CAN FD up to 5 Mbps)	$t_{\text{bit(BUS)}}$	155	-	210	ns	CAN Normal Mode; $C_L = 100\text{pF}$ ; $R_L = 60 \Omega$ ; $V_{\text{CAN}} = 5 \text{ V}$ ; $C_{\text{RXD}} = 15 \text{ pF}$ ; $t_{\text{bit(TXD)}} = 200 \text{ ns}$ ; Parameter definition in according to <a href="#">Figure 31</a> .	P_10.3.53
Receiver Timing Symmetry (CAN FD up to 5 Mbps)	$\Delta t_{\text{Rec}}$	-45	-	15	ns	CAN Normal Mode; $C_L = 100\text{pF}$ ; $R_L = 60 \Omega$ ; $V_{\text{CAN}} = 5 \text{ V}$ ; $C_{\text{RXD}} = 15 \text{ pF}$ ; $t_{\text{bit(TXD)}} = 200 \text{ ns}$ ; Parameter definition in according to <a href="#">Figure 31</a> .	P_10.3.54
TXD Permanent Dominant Time-out	$t_{\text{TXD\_CAN\_TO}}$	1.6	2	2.4	ms	<sup>4)</sup> CAN Normal Mode	P_10.3.36
BUS Permanent Dominant Time-out	$t_{\text{BUS\_CAN\_TO}}$	1.6	2	2.4	ms	<sup>4)</sup> CAN Normal Mode	P_10.3.37
Timeout for bus inactivity	$t_{\text{SILENCE}}$	0.6	-	1.2	s	<sup>4)</sup>	P_10.3.50
Bus Bias reaction time	$t_{\text{Bias}}$	-	-	200	$\mu\text{s}$	<sup>4)</sup>	P_10.3.51

High Speed CAN Transceiver

- 1) Not subject to production test, specified by design.
- 2)  $V_{SYM}$  shall be observed during dominant and recessive state and also during the transition dominant to recessive and vice versa while TXD is simulated by a square signal (50% duty cycle) with a frequency of up to 1 MHz (2 MBit/s);
- 3)  $R_{test}$  between supply (VS / VCAN) and 0V (GND);
- 4) Not subject to production test, tolerance defined by internal oscillator tolerance;
- 5) Wake-up is signaled via INT pin activation in SBC Stop Mode and via VCC1 ramping up with wake from SBC Sleep Mode;
- 6) Time starts with end of last dominant phase of WUP;

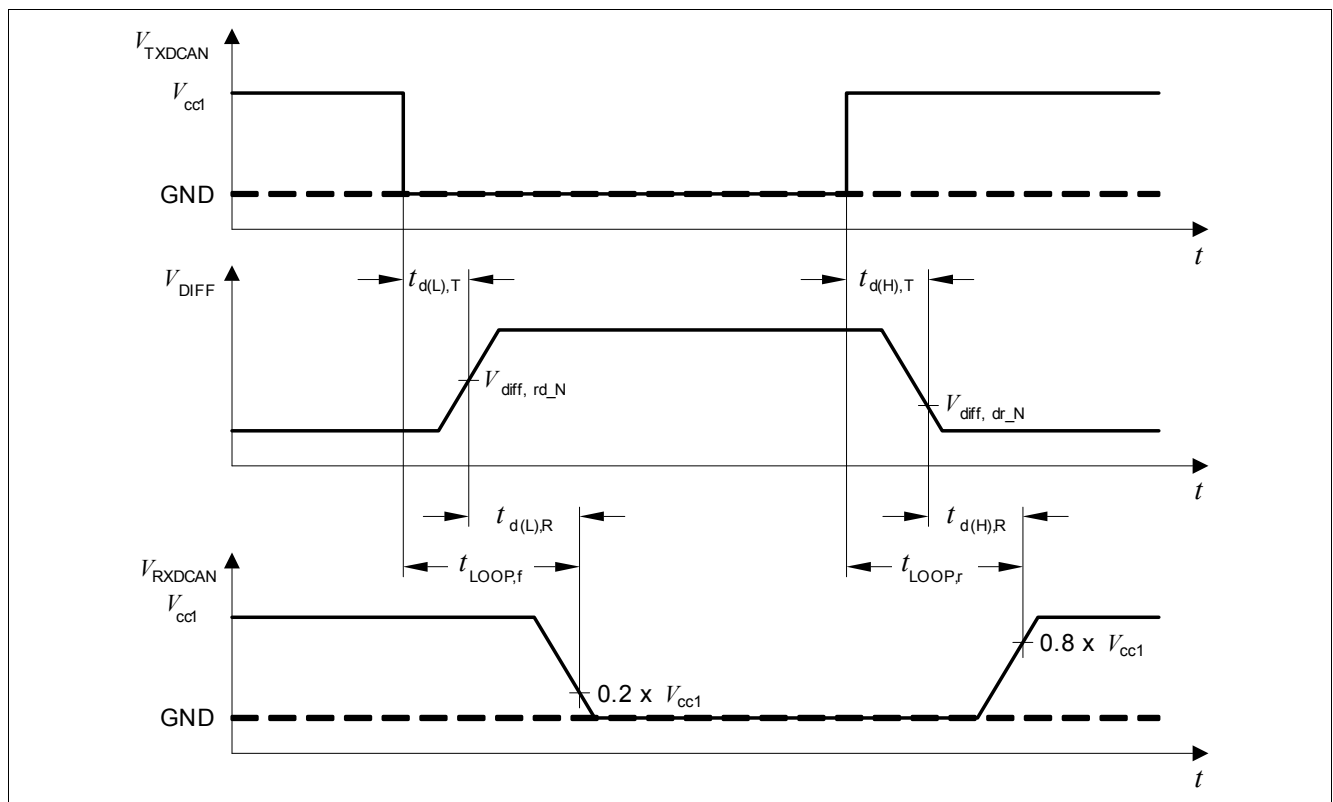


Figure 30 Timing Diagrams for Dynamic Characteristics

High Speed CAN Transceiver

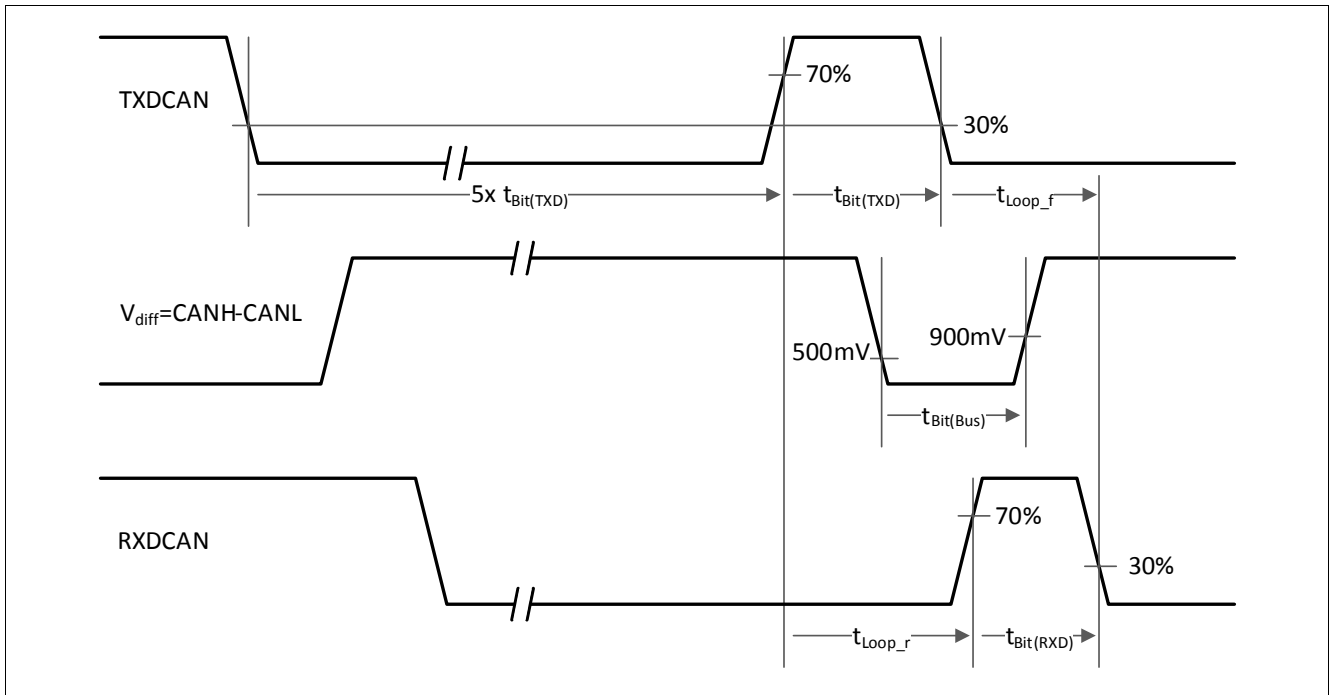


Figure 31 From ISO 11898-2: tloop, tbit(TXD), tbit(Bus), tbit(RXD) definitions

## 11 LIN Transceiver

### 11.1 Block Description

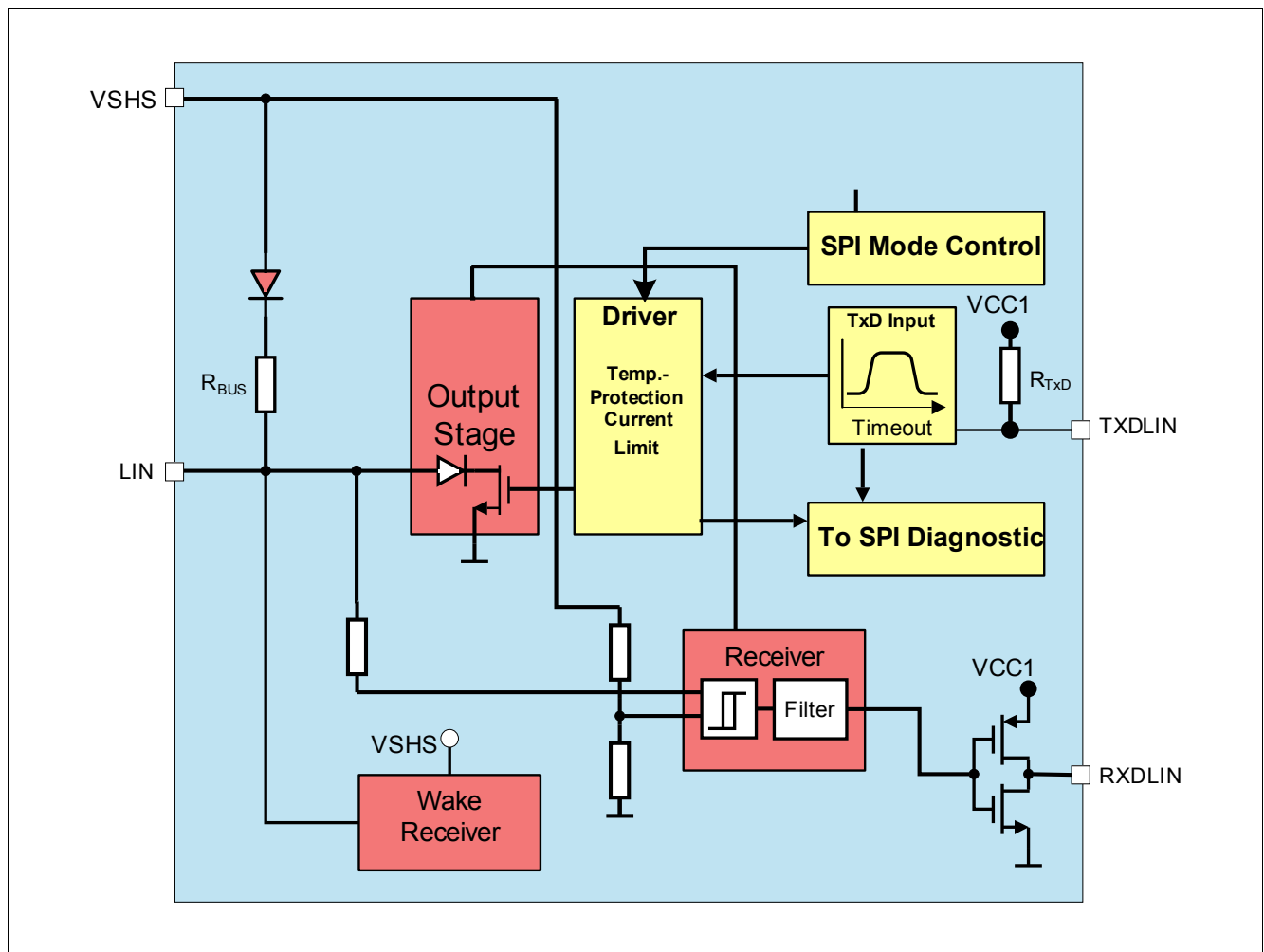


Figure 32 Block Diagram

#### 11.1.1 LIN Specifications

The LIN network is standardized by international regulations. The device is compliant to the specification LIN 2.2. The physical layer specification LIN 2.2a is a super set of the previous LIN specifications, like LIN 2.0 or LIN 1.3. The integrated LIN transceivers are according to the LIN 2.2 standard.

The device is compliant to the physical layer standard SAE-J2602-2. The SAE-J2602-2 standard differs from the LIN 2.2 standard mainly by the lower data rate (10.4 kbit/s).



LIN Transceiver

11.2 Functional Description

The LIN Bus is a single wire, bi-directional bus, used for in-vehicle networks. The LIN transceivers implemented inside the TLE9263BQXV33 are the interface between the micro controller and the physical LIN Bus. The digital output data from the micro controller are driven to the LIN bus via the TXD input pin on the TLE9263BQXV33. The transmit data stream on the TXD input is converted to a LIN bus signal with optimized slew rate to minimize the EME level of the LIN network. The RXD output sends back the information from the LIN bus to the micro controller. The receiver has an integrated filter network to suppress noise on the LIN Bus and to increase the EMI (Electro Magnetic Immunity) level of the transceiver.

Two logical states are possible on the LIN Bus according to the LIN Specification 2.2.

Every LIN network consists of a master node and one or more slave nodes. To configure the TLE9263BQXV33 for master node applications, a resistor in the range of 1 kΩ and a reverse diode must be connected between the LIN bus and the power supply VS<sub>HS</sub>.

The different transceiver modes can be controlled via the SPI LIN1 and LIN2 bits.

Figure 33 shows the possible transceiver mode transitions when changing the SBC mode.

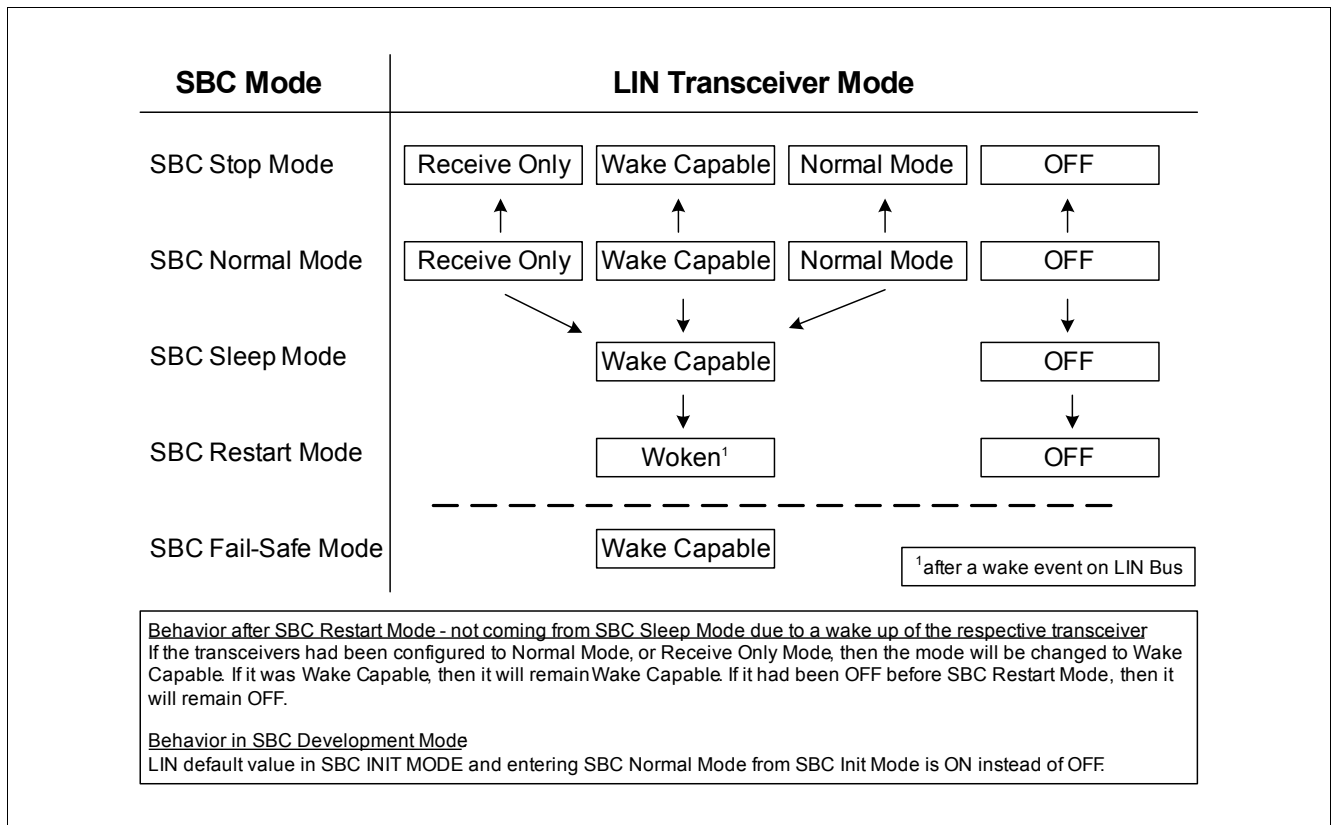


Figure 33 LIN Mode Control Diagram

11.2.1 LIN OFF Mode

The LIN OFF Mode is the default mode after power-up of the SBC. It is available in all SBC Modes and is intended to completely stop LIN activities or when LIN communication is not needed. In LIN OFF Mode, a wake-up event on the bus will be ignored.

**LIN Transceiver**

**11.2.2 LIN Normal Mode**

The LIN Transceiver is enabled via SPI in SBC Normal Mode. LIN Normal Mode is designed for normal data transmission/reception within the LIN network. The Mode is available in SBC Normal Mode and in SBC Stop Mode.

**Transmission**

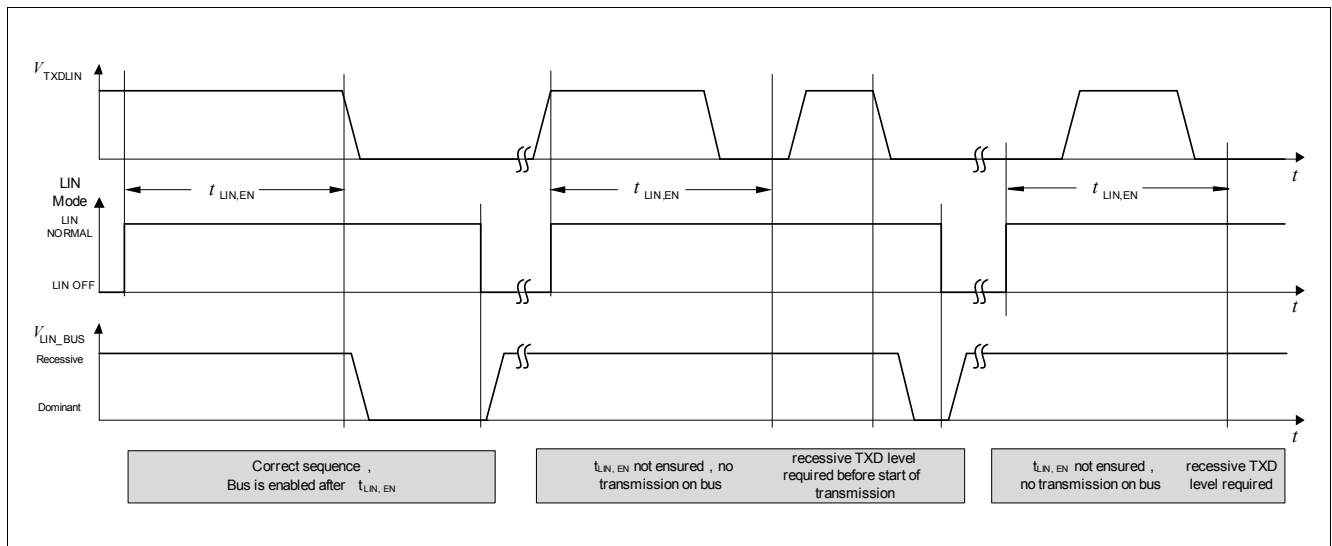
The signal from the microcontroller is applied to the TXDLIN input of the SBC. The bus driver switches the LIN output stage to transfer this input signal to the LIN bus line.

**Enabling Sequence**

The LIN transceiver requires an enabling time  $t_{LIN,EN}$  before a message can be sent on the bus. This means that the TXDLIN signal can only be pulled LOW after the enabling time. If this is not ensured, then the TXDLIN needs to be set back to high (=recessive) until the enabling time is completed.

Only the next dominant bit will be transmitted on the bus.

**Figure 34** shows different scenarios and explanations for LIN enabling.



**Figure 34 LIN Transceiver Enabling Sequence**

**Reduced Electromagnetic Emission**

To reduce electromagnetic emissions (EME), the bus driver controls LIN slopes symmetrically. The configuration of the different slopes is described in [Chapter 11.2.8](#).

**Reception**

Analog LIN bus signals are converted into digital signals at RXD via the differential input receiver.

**11.2.3 LIN Receive Only Mode**

In LIN Receive Only Mode (RXD only), the driver stage is de-activated but reception is still possible. This mode is accessible by an SPI command and is available in SBC Normal and SBC Stop Mode.

## LIN Transceiver

### 11.2.4 LIN Wake Capable Mode

This mode can be used in SBC Stop, Sleep, Restart and Normal Mode by programming via SPI and it is used to monitor bus activities. It is automatically accessed in SBC Fail-Safe Mode. A wake up is detected, if a recessive to dominant transition on the LIN bus is followed by a dominant level of longer than  $t_{WK,BUS}$ , followed by a dominant to recessive transition. The dominant to recessive transition will cause a wake up of the LIN transceiver. A wake-up results in a different behavior of the SBC, as described in below **Table 18**. As a signalization to the microcontroller, the RXD\_LIN pin is set LOW and will stay LOW until the LIN transceiver is changed to any other mode. After a wake-up event the transceiver can be switched to LIN Normal Mode for communication.

#### Rearming the transceiver for wake capability

After a BUS wake-up event, the transceiver is woken. However, the **LIN1** and **LIN2** transceiver mode bits will still show wake capable (=‘01’) so that the RXD signal will be pulled low. There are two possibilities how the LIN transceiver’s wake capable mode is enabled again after a wake event:

- The LIN transceiver mode must be toggled, i.e. switched to LIN Normal Mode, LIN Receive Only Mode or LIN Off, before switching to LIN Wake Capable Mode again.
- Rearming is done automatically when the SBC is changed to SBC Stop, SBC Sleep, or SBC Fail-Safe Mode to ensure wake-up capability.

#### Wake-Up in SBC Stop and SBC Normal Mode

In SBC Stop Mode, if a wake-up is detected, it is signaled by the INT output and in the **WK\_STAT\_1** SPI register. It is also signaled by RXDLIN put to LOW. The same applies for the SBC Normal Mode. The microcontroller should set the device to SBC Normal Mode, there is no automatic transition to Normal Mode.

For functional safety reasons, the watchdog will be automatically enabled in SBC Stop Mode after a Bus wake event in case it was disabled before (if bit **WD\_EN\_WK\_BUS** was configured to HIGH before).

#### Wake-Up in SBC Sleep Mode

Wake-up is possible via a LIN message (filter time  $t > t_{WK,BUS}$ ). The wake-up automatically transfers the SBC into the SBC Restart Mode and from there to Normal Mode the corresponding RXD pin in set to LOW. The microcontroller is able to detect the low signal on RXD and to read the wake source out of the **WK\_STAT\_1** register via SPI. No interrupt is generated when coming out of Sleep Mode. The microcontroller can now switch the LIN transceiver into LIN Normal Mode via SPI to start communication.

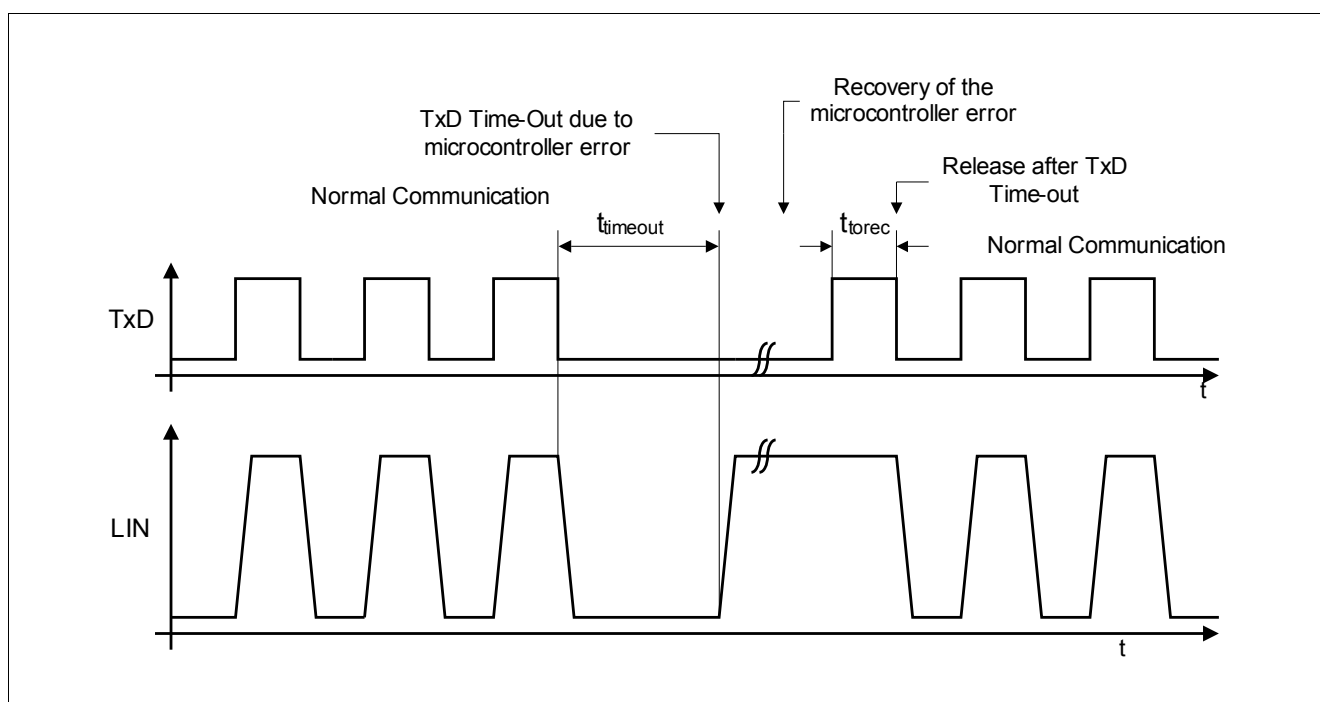
**Table 18 Action due to a LIN BUS Wake-up**

SBC Mode	SBC Mode after Wake	VCC1	INT	RXD
Normal Mode	Normal Mode	ON	LOW	LOW
Stop Mode	Stop Mode	ON	LOW	LOW
Sleep Mode	Restart Mode	Ramping Up	HIGH	LOW
Restart Mode	Restart Mode	ON	HIGH	LOW
Fail-Safe Mode	Restart Mode	Ramping up	HIGH	LOW

## LIN Transceiver

### 11.2.5 TXD Time-out Feature

If the TXD signal is dominant for the time  $t > t_{\text{TXD\_LIN\_TO}}$ , the TXD time-out function deactivates the LIN transmitter output stage temporarily. The transceiver remains in recessive state. The TXD time-out function prevents the LIN bus from being blocked by a permanent LOW signal on the TXD pin, caused by a failure. The failure is stored in the SPI flag **LIN1\_FAIL** and **LIN2\_FAIL**. The LIN transmitter stage is activated again after the dominant time-out condition is removed. The transceiver configuration stays unchanged.



**Figure 35 TXD Time-Out Function**

### 11.2.6 Bus Dominant Clamping

If the LIN bus signal is dominant for a time  $t > t_{\text{BUS\_LIN\_TO}}$  in LIN Normal and Receive Only Mode, then a bus dominant clamping is detected and the SPI bit **LIN1\_FAIL** and **LIN2\_FAIL** is set. The transceiver configuration stays unchanged.

### 11.2.7 Undervoltage Detection

In case the supply voltage is dropping below the VSHS undervoltage detection threshold ( $V_{\text{SHS}} < V_{\text{SHS,UVD}}$ ), the TLE9263BQXV33 disables the output and receiver stages. If the power supply reaches a higher level than the undervoltage detection threshold ( $V_{\text{SHS}} > V_{\text{SHS,UVD}}$ ), the TLE9263BQXV33 continues with normal operation. The transceiver configuration stays unchanged.

---

## LIN Transceiver

### 11.2.8 Slope Selection

The LIN transceiver offers a LIN Low-Slope Mode for 10.4 kBaud communication and a LIN Normal-Slope Mode for 20 kBaud communication. The only difference is the behavior of the transmitter. In LIN Low-Slope Mode, the

transmitter uses a lower slew rate to further reduce the EME compared to Normal-Slope Mode. This complies with SAE J2602 requirements. By default, the device works in LIN Normal-Slope Mode. The selection of LIN Low-Slope Mode is done by an SPI bit **LIN\_LSM** and will become effective as soon as CSN goes 'HIGH'. Only the LIN Slope is changed. The selection is accessible in SBC Normal Mode only.

### 11.2.9 Flash Programming via LIN

The device allows LIN flash programming, e.g. of another LIN Slave with a communication of up to 115 kBaud. This feature is enabled by de-activating the slope control mechanism via a SPI command (bit LIN\_FLASH) and will become effective as soon as CSN goes 'HIGH'. The SPI bit can be set in SBC Normal Mode.

*Note: It is recommended to perform flash programming only at nominal supply voltage  $V_{SHS} = 13.5V$  to ensure stable data communication.*

## LIN Transceiver

## 11.3 Electrical Characteristics

Table 19 Electrical Characteristics

$V_{SHS} = 5.5 \text{ V to } 18 \text{ V}$ ,  $T_j = -40 \text{ }^\circ\text{C to } +150 \text{ }^\circ\text{C}$ ,  $R_L = 500 \text{ } \Omega$ , all voltages with respect to ground, positive current flowing into pin (unless otherwise specified)

Parameter	Symbol	Values			Unit	Note or Test Condition	Number
		Min.	Typ.	Max.			
<b>Receiver Output (RXD pin)</b>							
HIGH Level Output Voltage	$V_{RXD,H}$	$0.8 \times V_{CC1}$	–	–	V	$I_{RXD} = -1.6 \text{ mA}$ ; $V_{Bus} = V_{SHS}$	P_11.3.1
LOW Level Output Voltage	$V_{RXD,L}$	–	–	$0.2 \times V_{CC1}$	V	$I_{RXD} = 1.6 \text{ mA}$ $V_{Bus} = 0 \text{ V}$	P_11.3.2
<b>Transmission Input (TXD pin)</b>							
HIGH Level Input Voltage	$V_{TXD,H}$	$0.7 \times V_{CC1}$	–	–	V	Recessive State	P_11.3.3
TXD Input Hysteresis	$V_{TXD,hys}$	$0.08 \times V_{CC1}$	$0.12 \times V_{CC1}$	$0.5 \times V_{CC1}$	V	<sup>1)</sup>	P_11.3.4
LOW Level Input Voltage	$V_{TXD,L}$	–	–	$0.3 \times V_{CC1}$	V	Dominant State	P_11.3.5
TXD Pull-up Resistance	$R_{TXD}$	20	40	80	k $\Omega$	$V_{TXD} = 0 \text{ V}$	P_11.3.6
<b>LIN Bus Receiver (LIN Pin)</b>							
Receiver Threshold Voltage, Recessive to Dominant Edge	$V_{Bus,rd}$	$0.4 \times V_{SHS}$	$0.45 \times V_{SHS}$	–	V		P_11.3.7
Receiver Dominant State	$V_{Bus,dom}$	–	–	$0.4 \times V_{SHS}$	V	LIN 2.2 Param. 17	P_11.3.8
Receiver Threshold Voltage, Dominant to Recessive Edge	$V_{Bus,dr}$	–	$0.55 \times V_{SHS}$	$0.60 \times V_{SHS}$	V		P_11.3.9
Receiver Recessive State	$V_{Bus,rec}$	$0.6 \times V_{SHS}$	–	–	V	LIN 2.2 Param 18	P_11.3.10
Receiver Center Voltage	$V_{Bus,c}$	$0.475 \times V_{SHS}$	$0.5 \times V_{SHS}$	$0.525 \times V_{SHS}$	V	LIN 2.2 Param 19 $6 \text{ V} < V_{SHS} < 18 \text{ V}$	P_11.3.11
Receiver Hysteresis	$V_{Bus,hys}$	$0.07 \times V_{SHS}$	$0.1 \times V_{SHS}$	$0.175 \times V_{SHS}$	V	$V_{bus,hys} = V_{bus,dr} - V_{bus,rd}$ LIN 2.2 Param 20	P_11.3.12
Wake-up Threshold Voltage	$V_{Bus,wk}$	$0.40 \times V_{SHS}$	$0.5 \times V_{SHS}$	$0.6 \times V_{SHS}$	V	–	P_11.3.13
Dominant Time for Bus Wake-up	$t_{WK,Bus}$	30	–	150	$\mu\text{s}$	<sup>2)</sup>	P_11.3.14

## LIN Transceiver

**Table 19 Electrical Characteristics (cont'd)**

$V_{SHS} = 5.5 \text{ V to } 18 \text{ V}$ ,  $T_j = -40 \text{ }^\circ\text{C to } +150 \text{ }^\circ\text{C}$ ,  $R_L = 500 \text{ } \Omega$ , all voltages with respect to ground, positive current flowing into pin (unless otherwise specified)

Parameter	Symbol	Values			Unit	Note or Test Condition	Number
		Min.	Typ.	Max.			
<b>LIN Bus Transmitter (LIN Pin)</b>							
Bus Serial Diode Voltage Drop	$V_{\text{serdiode}}$	0.4	0.7	1.0	V	<sup>1)</sup> $V_{\text{TXD}} = \text{VCC1}$ ; LIN 2.2 Param 21	P_11.3.15
Bus Recessive Output Voltage	$V_{\text{BUS,ro}}$	$0.8 \times V_{\text{SHS}}$	–	$V_{\text{SHS}}$	V	$V_{\text{TXD}} = \text{HIGH Level}$	P_11.3.16
Bus Short Circuit Current	$I_{\text{BUS,sc}}$	40	100	150	mA	$V_{\text{BUS}} = 18 \text{ V}$ ; LIN 2.2 Param 12	P_11.3.17
Leakage Current Loss of Ground	$I_{\text{BUS,lk1}}$	-1000	-450	20	$\mu\text{A}$	$V_{\text{SHS}} = 12 \text{ V} = \text{GND}$ ; $0 \text{ V} < V_{\text{BUS}} < 18 \text{ V}$ ; LIN 2.2 Param 15	P_11.3.18
Leakage Current Loss of Battery	$I_{\text{BUS,lk2}}$	–	–	20	$\mu\text{A}$	$V_{\text{SHS}} = 0 \text{ V}$ ; $V_{\text{BUS}} = 18 \text{ V}$ ; LIN 2.2 Param 16	P_11.3.19
Leakage Current Driver Off	$I_{\text{BUS,lk3}}$	-1	–	–	mA	$V_{\text{SHS}} = 18 \text{ V}$ ; $V_{\text{BUS}} = 0 \text{ V}$ ; LIN 2.2 Param 13	P_11.3.20
Leakage Current Driver Off	$I_{\text{BUS,lk4}}$	–	–	20	$\mu\text{A}$	$V_{\text{SHS}} = 8 \text{ V}$ ; $V_{\text{BUS}} = 18 \text{ V}$ ; LIN 2.2 Param 14	P_11.3.21
Bus Pull-up Resistance	$R_{\text{BUS}}$	20	30	47	k $\Omega$	Normal Mode LIN 2.2 Param 26	P_11.3.22
LIN Input Capacitance	$C_{\text{BUS}}$		20	25	pF	<sup>1)</sup>	P_11.3.23
Receiver propagation delay bus dominant to RXD LOW	$t_{\text{d(L),R}}$	–	1	6	$\mu\text{s}$	$V_{\text{CC}} = 3.3 \text{ V}$ ; $C_{\text{RXD}} = 20 \text{ pF}$ ; LIN 2.2 Param 31	P_11.3.24
Receiver propagation delay bus recessive to RXD HIGH	$t_{\text{d(H),R}}$	–	1	6	$\mu\text{s}$	$V_{\text{CC}} = 3.3 \text{ V}$ ; $C_{\text{RXD}} = 20 \text{ pF}$ ; LIN 2.2 Param 31	P_11.3.25
Receiver delay symmetry	$t_{\text{sym,R}}$	-2	–	2	$\mu\text{s}$	$t_{\text{sym,R}} = t_{\text{d(L),R}} - t_{\text{d(H),R}}$ ; LIN 2.2 Param 32	P_11.3.26
LIN Transceiver Enabling Time	$t_{\text{LIN,EN}}$	8	13	18	$\mu\text{s}$	<sup>2)</sup> CSN = HIGH to first valid transmitted TXD dominant	P_11.3.27
Bus Dominant Time Out	$t_{\text{BUS\_LIN\_TO}}$	16	20	24	ms	<sup>1)2)</sup>	P_11.3.28
TXD Dominant Time Out	$t_{\text{TXD\_LIN\_TO}}$	16	20	24	ms	<sup>1)2)</sup> $V_{\text{TXD}} = 0 \text{ V}$	P_11.3.29
TXD Dominant Time Out Recovery Time	$t_{\text{torec}}$	5	10	14	$\mu\text{s}$	<sup>1)2)</sup>	P_11.3.30

## LIN Transceiver

**Table 19 Electrical Characteristics (cont'd)**

$V_{SHS} = 5.5 \text{ V to } 18 \text{ V}$ ,  $T_j = -40 \text{ }^\circ\text{C to } +150 \text{ }^\circ\text{C}$ ,  $R_L = 500 \text{ } \Omega$ , all voltages with respect to ground, positive current flowing into pin (unless otherwise specified)

Parameter	Symbol	Values			Unit	Note or Test Condition	Number
		Min.	Typ.	Max.			
Duty Cycle D1 (For worst case at 20 kbit/s) LIN 2.2 Normal Slope	D1	0.396	–	–		<sup>3)</sup> $TH_{Rec}(max) = 0.744 \times V_{SHS}$ ; $TH_{Dom}(max) = 0.581 \times V_{SHS}$ ; $V_{SHS} = 7.0 \dots 18 \text{ V}$ ; $t_{bit} = 50 \text{ } \mu\text{s}$ ; $D1 = t_{bus\_rec(min)}/2 t_{bit}$ ; LIN 2.2 Param 27	P_11.3.31
Duty Cycle D2 (for worst case at 20 kbit/s) LIN 2.2 Normal Slope	D2	–	–	0.581		<sup>3)</sup> $TH_{Rec}(min.) = 0.422 \times V_{SHS}$ ; $TH_{Dom}(min.) = 0.284 \times V_{SHS}$ ; $V_{SHS} = 7.6 \dots 18 \text{ V}$ ; $t_{bit} = 50 \text{ } \mu\text{s}$ ; $D2 = t_{bus\_rec(max)}/2 t_{bit}$ ; LIN 2.2 Param 28	P_11.3.32
Duty Cycle D3 (for worst case at 10.4 kbit/s) SAE J2602 Low Slope	D3	0.417	–	–		<sup>3)</sup> $TH_{Rec}(max) = 0.778 \times V_{SHS}$ ; $TH_{Dom}(max) = 0.616 \times V_{SHS}$ ; $V_{SHS} = 7.0 \dots 18 \text{ V}$ ; $t_{bit} = 96 \text{ } \mu\text{s}$ ; $D3 = t_{bus\_rec(min)}/2 t_{bit}$ ; LIN 2.2 Param 29	P_11.3.33
Duty Cycle D4 (for worst case at 10.4 kbit/s) SAE J2602 Low Slope	D4	–	–	0.590		<sup>3)</sup> $TH_{Rec}(min.) = 0.389 \times V_{SHS}$ ; $TH_{Dom}(min.) = 0.251 \times V_{SHS}$ ; $V_{SHS} = 7.6 \dots 18 \text{ V}$ ; $t_{bit} = 96 \text{ } \mu\text{s}$ ; $D4 = t_{bus\_rec(max)}/2 t_{bit}$ ; LIN 2.2 Param 30	P_11.3.34

- 1) Not subject to production test, specified by design.
- 2) Not subject to production test, tolerance defined by internal oscillator tolerance
- 3) Bus load conditions concerning LIN Specification 2.2  $C_{LIN}$ ,  $R_{LIN} = 1 \text{ nF}$ ,  $1 \text{ k}\Omega / 6.8 \text{ nF}$ ,  $660 \text{ } \Omega / 10 \text{ nF}$ ,  $500 \text{ } \Omega$



LIN Transceiver

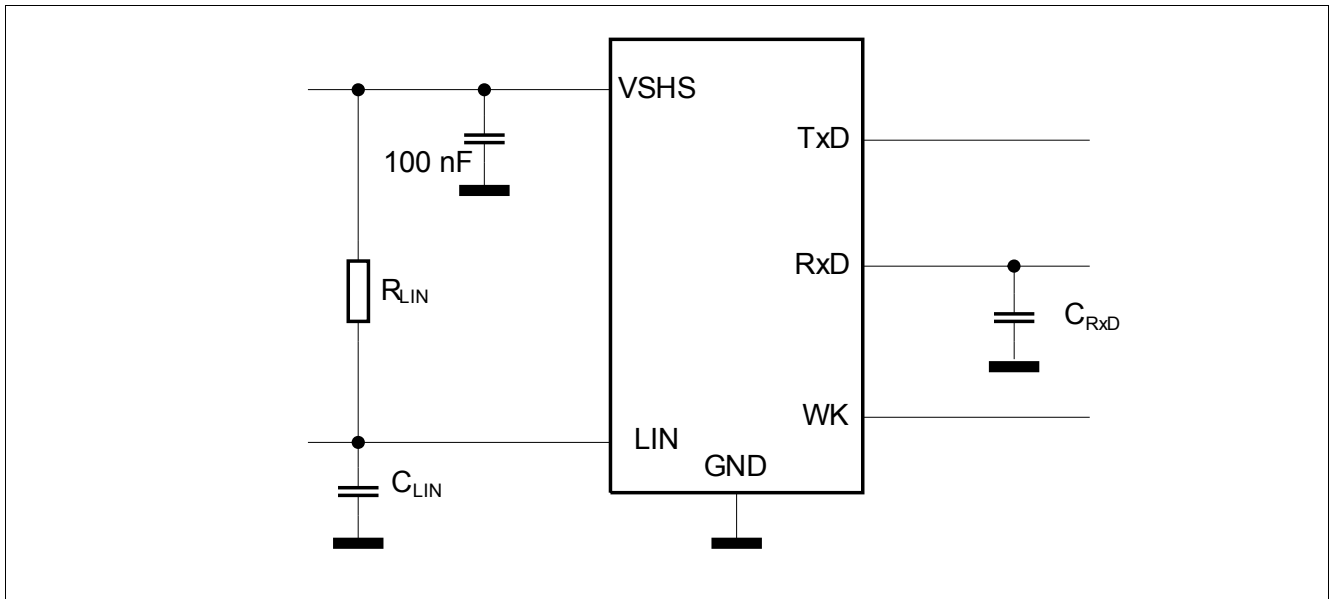


Figure 36 Simplified Test Circuit for Dynamic Characteristics

LIN Transceiver

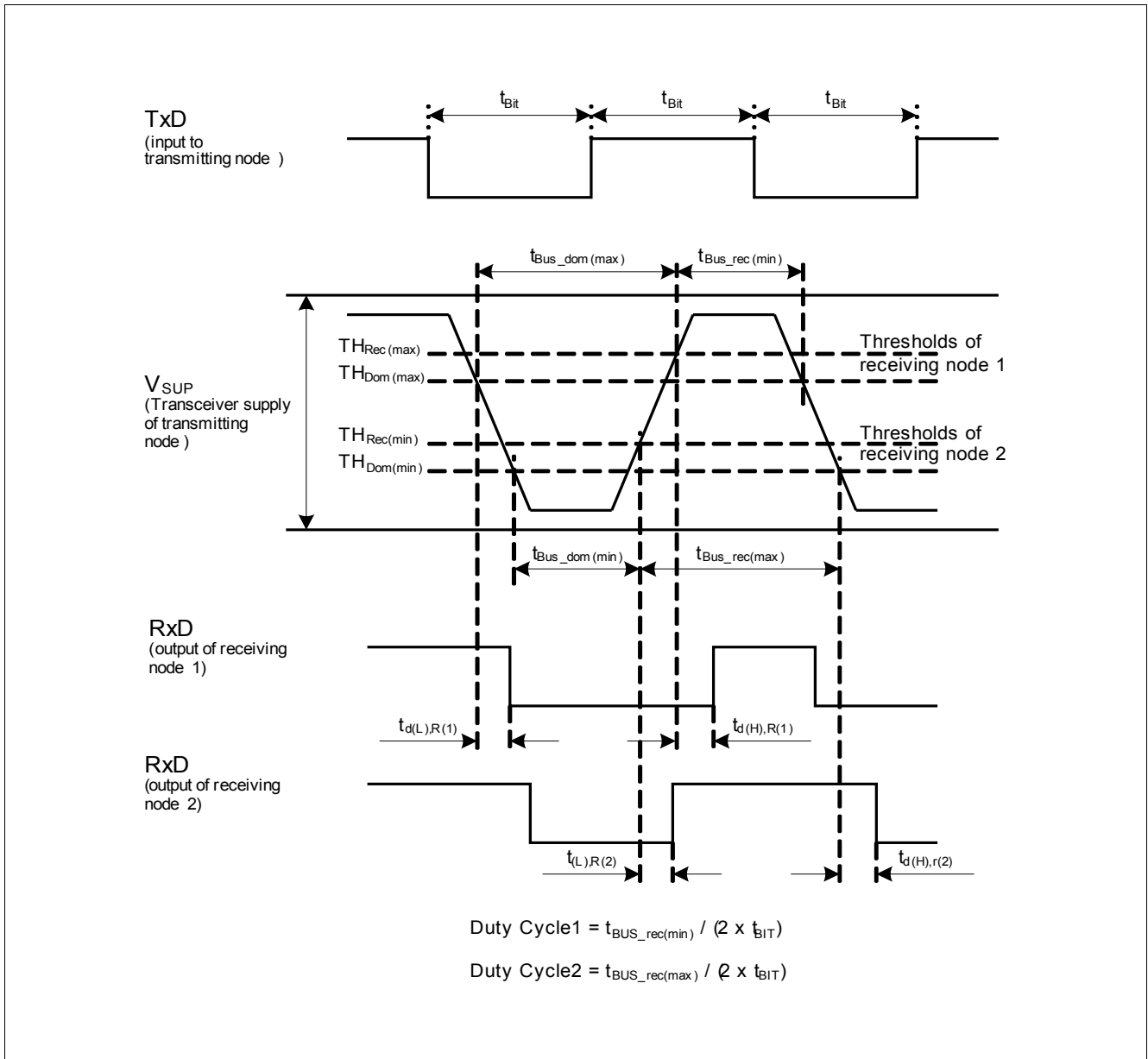
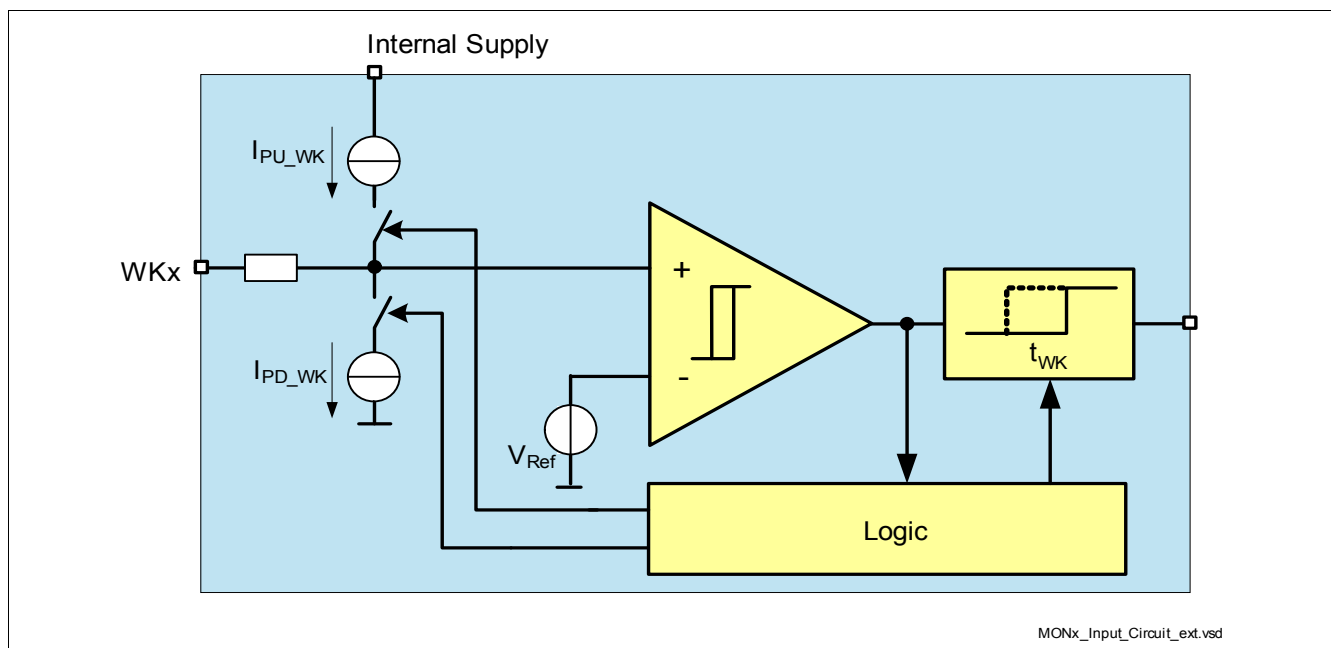


Figure 37 Timing Diagram for Dynamic Characteristics

## Wake and Voltage Monitoring Inputs

# 12 Wake and Voltage Monitoring Inputs

## 12.1 Block Description



**Figure 38** Wake Input Block Diagram

### Features

- Three High-Voltage inputs with a 3V (typ.) threshold voltage
- Alternate Measurement function for high-voltage sensing via WK1 and WK2
- Wake-up capability for power saving modes
- Edge sensitive wake feature LOW to HIGH and HIGH to LOW
- Pull-up and Pull-down current sources, configurable via SPI
- Selectable configuration for static sense or cyclic sense working with TIMER1, TIMER2
- In SBC Normal and SBC Stop Mode the level of the WK pin can be read via SPI even if the respective WK is not enabled as a wake source.

## Wake and Voltage Monitoring Inputs

### 12.2 Functional Description

The wake input pins are edge-sensitive inputs with a switching threshold of typically 3V. This means that both transitions, HIGH to LOW and LOW to HIGH, result in a signalization by the SBC. The signalization occurs either in triggering the interrupt in SBC Normal Mode and SBC Stop Mode or by a wake up of the device in SBC Sleep and SBC Fail-Safe Mode.

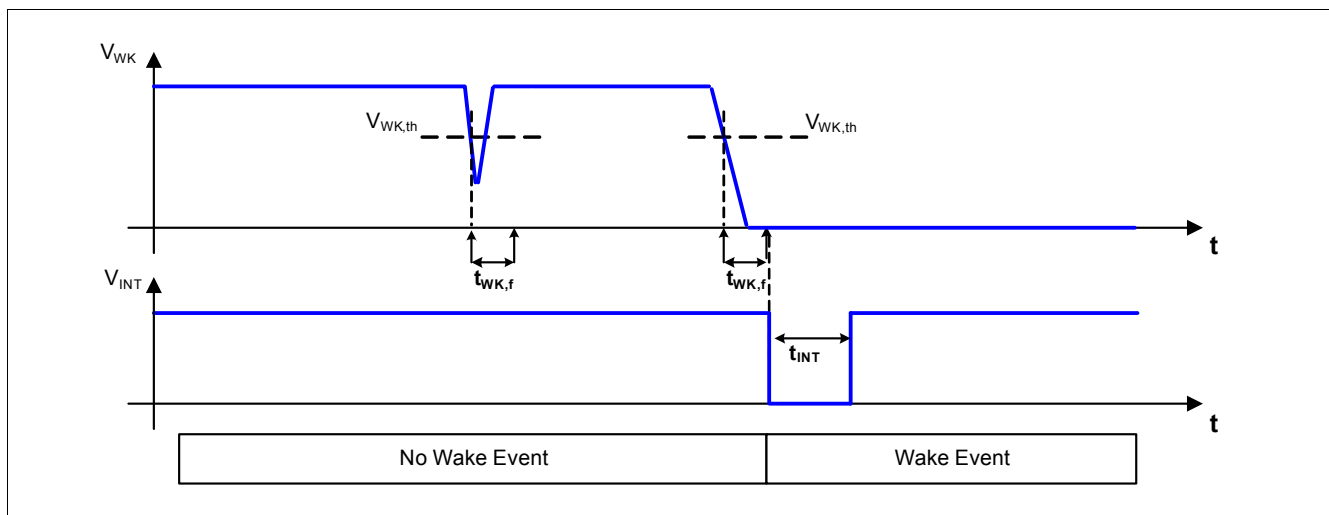
Two different wake detection modes can be selected via SPI:

- Static sense: WK inputs are always active
- Cyclic sense: WK inputs are only active for a certain time period (see [Chapter 5.2.1](#))

Two different filter times of 16 $\mu$ s or 64 $\mu$ s can be selected to avoid a parasitic wake-up due to transients or EMC disturbances in static sense configuration.

The filter time ( $t_{FWK1}$ ,  $t_{FWK2}$ ) is triggered by a level change crossing the switching threshold and a wake signal is recognized if the input level will not cross again the threshold during the selected filter time.

[Figure 39](#) shows a typical wake-up timing and parasitic filter.



**Figure 39** Wake-up Filter Timing for Static Sense

The wake-up capability for each WK pin can be enabled or disabled via SPI command in the [WK\\_CTRL\\_2](#) register.

The wake source for a wake via a WKx pin can always be read in the register [WK\\_STAT\\_1](#) at the bits WK1\_WU, WK2\_WU, and WK3\_WU.

The actual voltage level of the WK pin (LOW or HIGH) can always be read in SBC Normal and SBC Stop Mode in the register [WK\\_LVL\\_STAT](#). During Cyclic Sense, the register show the sampled levels of the respective WK pin.

If FO2...3 are configured as WK inputs in its alternative function (16 $\mu$ s static filter time), then the wake events will be signalled in the register [WK\\_STAT\\_2](#).

Wake and Voltage Monitoring Inputs

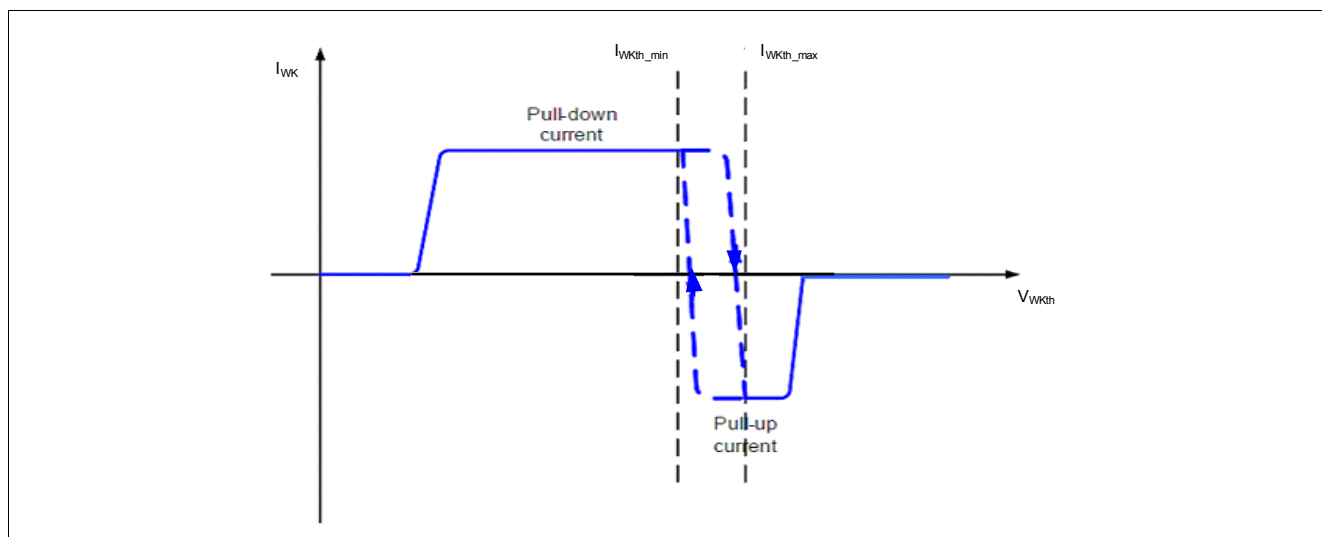
12.2.1 Wake Input Configuration

To ensure a defined and stable voltage levels at the internal comparator input it is possible to configure integrated current sources via the SPI register **WK\_PUPD\_CTRL**. In addition, the wake detection modes (including the filter time) can be configured via the SPI register **WK\_FLT\_CTRL**. An example illustration for the automatic switching configuration is shown in **Figure 40**.

**Table 20 Pull-Up / Pull-Down Resistor**

WKx_PUPD_1	WKx_PUPD_0	Current Sources	Note
0	0	no current source	WKx input is floating if left open (default setting)
0	1	pull-down	WKx input internally pulled to GND
1	0	pull-up	WKx input internally pulled to internal 5V supply
1	1	Automatic switching	If a high level is detected at the WKx input the pull-up source is activated, if low level is detected the pull down is activated.

*Note: If there is no pull-up or pull-down configured on the WK input, then the respective input should be tied to GND or VS on board to avoid unintended floating of the pin and subsequent wake events.*



**Figure 40 Illustration for Pull-Up / Down Current Sources with Automatic Switching Configuration**

**Table 21 Wake Detection Configuration and Filter Time**

WKx_FLT_1	WKx_FLT_0	Filter Time	Description
0	0	Config A	static sense, 16µs filter time
0	1	Config B	static sense, 64µs filter time
1	0	Config C	Cyclic sense, Timer 1, 16µs filter time. Period, On-time configurable in register <b>TIMER1_CTRL</b>
1	1	Config D	Cyclic sense, Timer 2, 16µs filter time. Period, On-time configurable in register <b>TIMER2_CTRL</b>

Config A and B are intended for static sense with two different filter times.

---

**Wake and Voltage Monitoring Inputs**

Config C or D are intended for cyclic sense configuration. With the filter settings, the respective timer needs to be assigned to one or more HS output, which supplies an external circuit connected to the WKx pin, e.g. HS1 controlled by Timer 2 (HS1 = 010) and connected to WK3 via an switch circuitry - see also [Chapter 5.2](#).

## Wake and Voltage Monitoring Inputs

### 12.2.2 Alternate Measurement Function with WK1 and WK2

#### 12.2.2.1 Block Description

This function provides the possibility to measure a voltage, e.g. the unbuffered battery voltage, with the protected WK1 HV-input. The measured voltage is routed out at WK2. It allows for example a voltage compensation for LED lighting by changing the duty cycle of the High-Side outputs. A simple voltage divider needs to be placed externally to provide the correct voltage level to the microcontroller A/D converter input.

The function is available in SBC Normal Mode and it is disabled in all other modes to allow a low-quiescent current operation. The measurement function can be used instead of the WK1 and WK2 wake and level signalling capability.

The benefits of the function is that the signal is measured by a HV-input pin and that there is no current flowing through the resistor divider during low-power modes.

The functionality is shown in a simplified application diagram in [Figure 60](#).

#### 12.2.2.2 Functional Description

This measurement function is by default disabled. In this case, WK1 and WK2 have the regular wake and voltage level signalization functionality. The switch S1 is open for this configuration (see [Figure 60](#)).

The measurement function can be enabled via the SPI bit [WK\\_MEAS](#).

If [WK\\_MEAS](#) is set to '1', then the measurement function is enabled and switch S1 is closed in SBC Normal Mode. S1 is open in all other SBC modes. If this function the pull-up and down currents of WK1 and WK2 are disabled, and the internal WK1 and WK2 signals are gated. In addition, the settings for WK1 and WK2 in the registers [WK\\_PUPD\\_CTRL](#), [WK\\_FLT\\_CTRL](#) and [WK\\_CTRL\\_2](#) are ignored but changing these setting is not prevented. The registers [WK\\_STAT\\_1](#) and [WK\\_LVL\\_STAT](#) are not updated with respect to the inputs WK1 and WK2.

However, if only WK1 or WK2 are set as wake sources and a SBC Sleep Mode command is set, then the [SPI\\_FAIL](#) flag will be set and the SBC will be changed into SBC Restart Mode (see [Chapter 5.1](#) also for wake capability of WK1 and WK2).

**Table 22 Differences between Normal WK Function and Measurement Function**

Affected Settings/Modules for WK1 and WK2 Inputs	<a href="#">WK_MEAS</a> = 0	<a href="#">WK_MEAS</a> = 1
S1 configuration	'open'	'closed' in SBC Normal Mode, 'open' in all other SBC Modes
Internal WK1 & WK2 signal processing	Default wake and level signaling function, <a href="#">WK_STAT_1</a> , <a href="#">WK_STAT_2</a> are updated accordingly	'WK1...2 inputs are gated internally, <a href="#">WK_STAT_1</a> , <a href="#">WK_STAT_2</a> are not updated
<a href="#">WK1_EN</a> , <a href="#">WK2_EN</a>	Wake-up via WK1 and WK2 possible if bits are set	setting the bits is ignored and not prevented. If only <a href="#">WK1_EN</a> , <a href="#">WK2_EN</a> are set while trying to go to SBC Sleep Mode, then the <a href="#">SPI_FAIL</a> flag will be set and the SBC will be changed into SBC Restart Mode.
<a href="#">WK_PUPD_CTRL</a>	normal configuration is possible	no pull-up or pull-down enabled
<a href="#">WK_FLT_CTRL</a>	normal configuration is possible	setting the bits is ignored and not prevented

## Wake and Voltage Monitoring Inputs

Note: There is a diode in series to the switch S1 (not shown in the [Figure 60](#)), which will influence the temperature behavior of the switch.

### 12.3 Electrical Characteristics

**Table 23 Electrical Characteristics**

$V_S = 5.5\text{ V to }28\text{ V}$ ;  $T_j = -40\text{ °C to }+150\text{ °C}$ ; all voltages with respect to ground, positive current flowing into pin (unless otherwise specified)

Parameter	Symbol	Values			Unit	Note or Test Condition	Number
		Min.	Typ.	Max.			
<b>WK1...WK3 Input Pin Characteristics</b>							
Wake-up/monitoring threshold voltage	$V_{WKth}$	2	3	4	V	without external serial resistor $R_S$ (with $R_S$ : $\Delta V = I_{PD/PU} * R_S$ ); hysteresis included	P_12.3.1
Threshold hysteresis	$V_{WKth,hys}$	0.1	-	0.7	V	without external serial resistor $R_S$ (with $R_S$ : $\Delta V = I_{PD/PU} * R_S$ );	P_12.3.2
WK pin Pull-up Current	$I_{PU\_WK}$	-20	-10	-3	$\mu\text{A}$	$V_{WK\_IN} = 4\text{V}$	P_12.3.3
WK pin Pull-down Current	$I_{PD\_WK}$	3	10	20	$\mu\text{A}$	$V_{WK\_IN} = 2\text{V}$	P_12.3.4
Input leakage current	$I_{LK,l}$	-2		2	$\mu\text{A}$	$0\text{ V} < V_{WK\_IN} < 40\text{V}$	P_12.3.5
Drop Voltage across S1 switch	$V_{Drop,S1}$	-	1000	1100	mV	<sup>1)</sup> Drop Voltage between WK1 and WK2 when enabled for voltage measurement; $I_{WK1} = 500\mu\text{A}$ ; $T_j = 25\text{°C}$ Refer to <a href="#">Figure 41</a>	P_12.3.13

#### Timing

Wake-up filter time 1	$t_{FWK1}$	12	16	20	$\mu\text{s}$	<sup>2)</sup> SPI Setting	P_12.3.6
Wake-up filter time 2	$t_{FWK2}$	50	64	80	$\mu\text{s}$	<sup>2)</sup> SPI Setting	P_12.3.7

1) Not subject to production test; specified by design

2) Not subject to production test, tolerance defined by internal oscillator tolerance



Wake and Voltage Monitoring Inputs

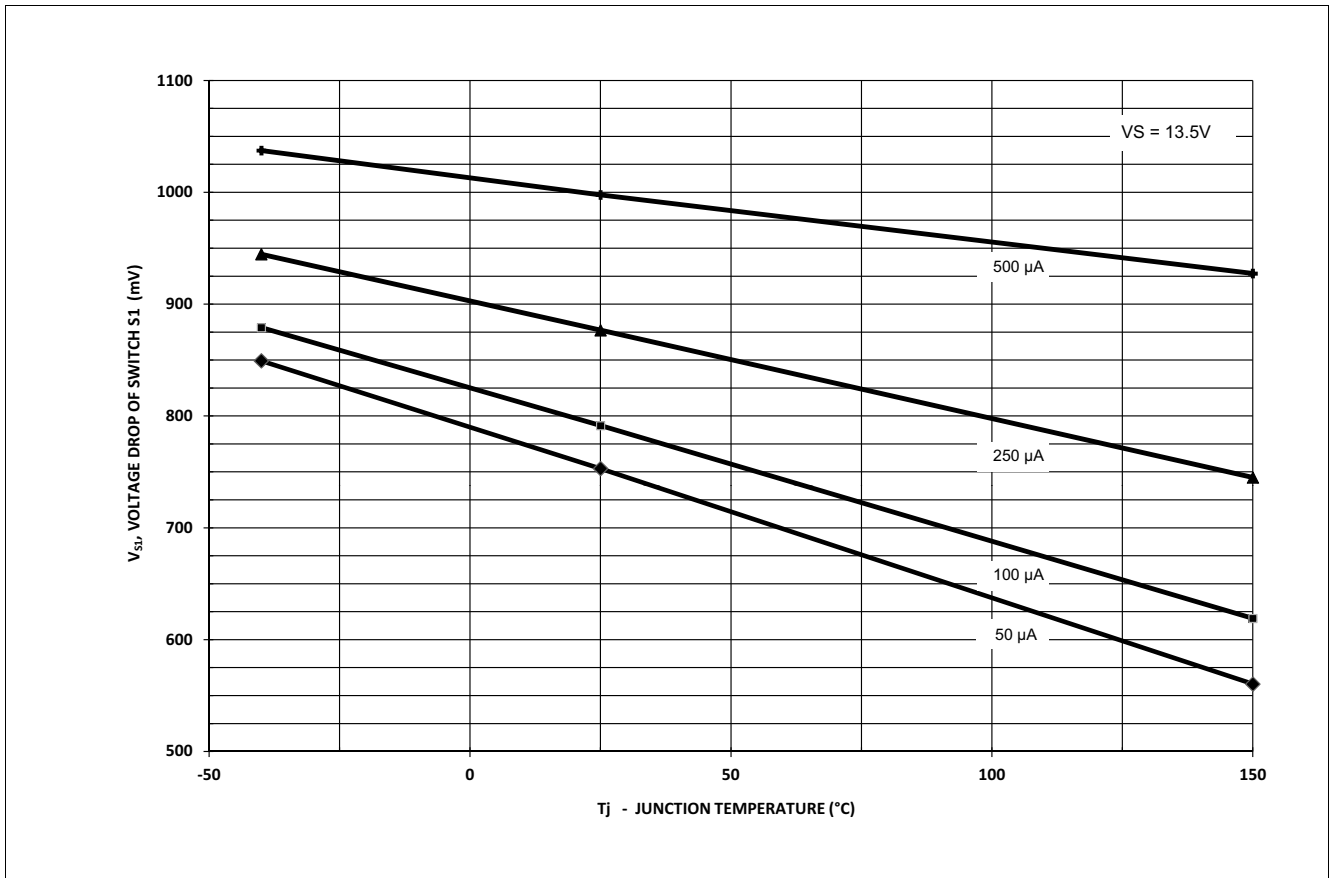
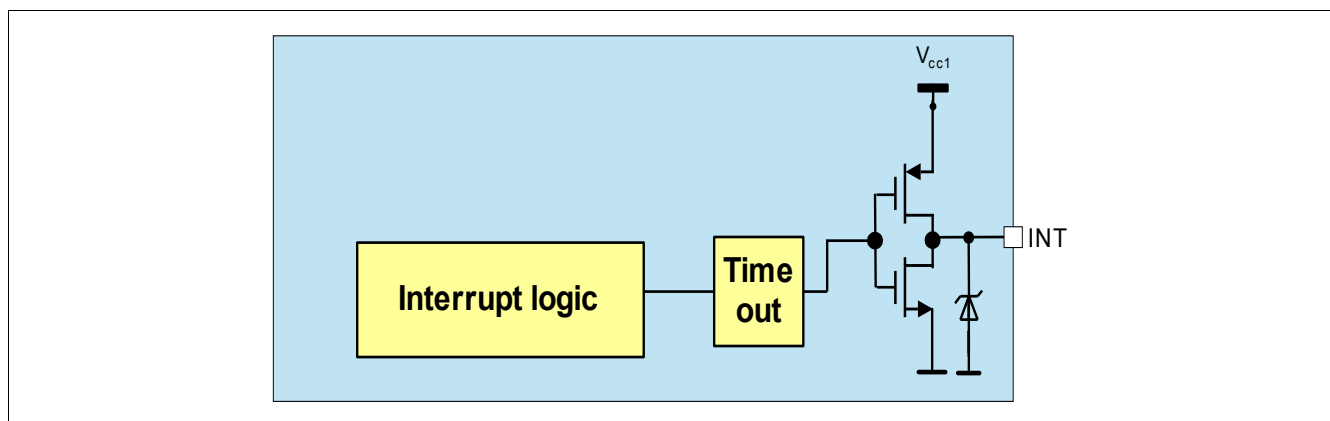


Figure 41 Typical Drop Voltage Characteristics of S1 (between WK1 & WK2)

## Interrupt Function

### 13 Interrupt Function

#### 13.1 Block and Functional Description



**Figure 42** Interrupt Block Diagram

The interrupt is used to signalize special events in real time to the microcontroller. The interrupt block is designed as a push/pull output stage as shown in **Figure 42**. An interrupt is triggered and the INT pin is pulled low (active low) for  $t_{INT}$  in SBC Normal and Stop Mode and it is released again once  $t_{INT}$  is expired. The minimum HIGH-time of INT between two consecutive interrupts is  $t_{INTD}$ . An interrupt does not cause a SBC mode change. Two different interrupt classes could be selected via the SPI bit **INT\_GLOBAL**:

- Class 1 (wake interrupt - **INT\_GLOBAL**=0): all wake-up events stored in the wake status SPI register (**WK\_STAT\_1** and **WK\_STAT\_2**) cause an interrupt (default setting). An interrupt is only triggered if the respective function is also enabled as a wake source (including GPIOx if configured as a wake input).
- Class 2 (global interrupt - **INT\_GLOBAL**=1): in addition to the wake-up events, all signalled failures stored in the other status registers cause an interrupt (the register **WK\_LVL\_STAT** is not generating interrupts)

*Note: The errors which will cause SBC Restart or SBC Fail-Safe Mode (Vcc1\_UV, WD\_FAIL, VCC1\_SC, TSD2, FAILURE) are the exceptions of an INT generation on status bits. Also POR and DEV\_STAT\_x and will not generate interrupts.*

In addition to this behavior, an INT will be triggered when the SBC is sent to SBC Stop Mode and not all bits were cleared in the **WK\_STAT\_1** and **WK\_STAT\_2** register.

The SPI status registers are updated at every falling edge of the INT pulse. All interrupt events are stored in the respective register (except the register **WK\_LVL\_STAT**) until the register is read and cleared via SPI command. A second SPI read after reading out the respective status register is optional but recommended to verify that the interrupt event is not present anymore. The interrupt behavior is shown in **Figure 43** for class 1 interrupts. The behavior for class 2 is identical.

The INT pin is also used during SBC Init Mode to select the hardware configuration of the device. See **Chapter 5.1.1** for further information.

Interrupt Function

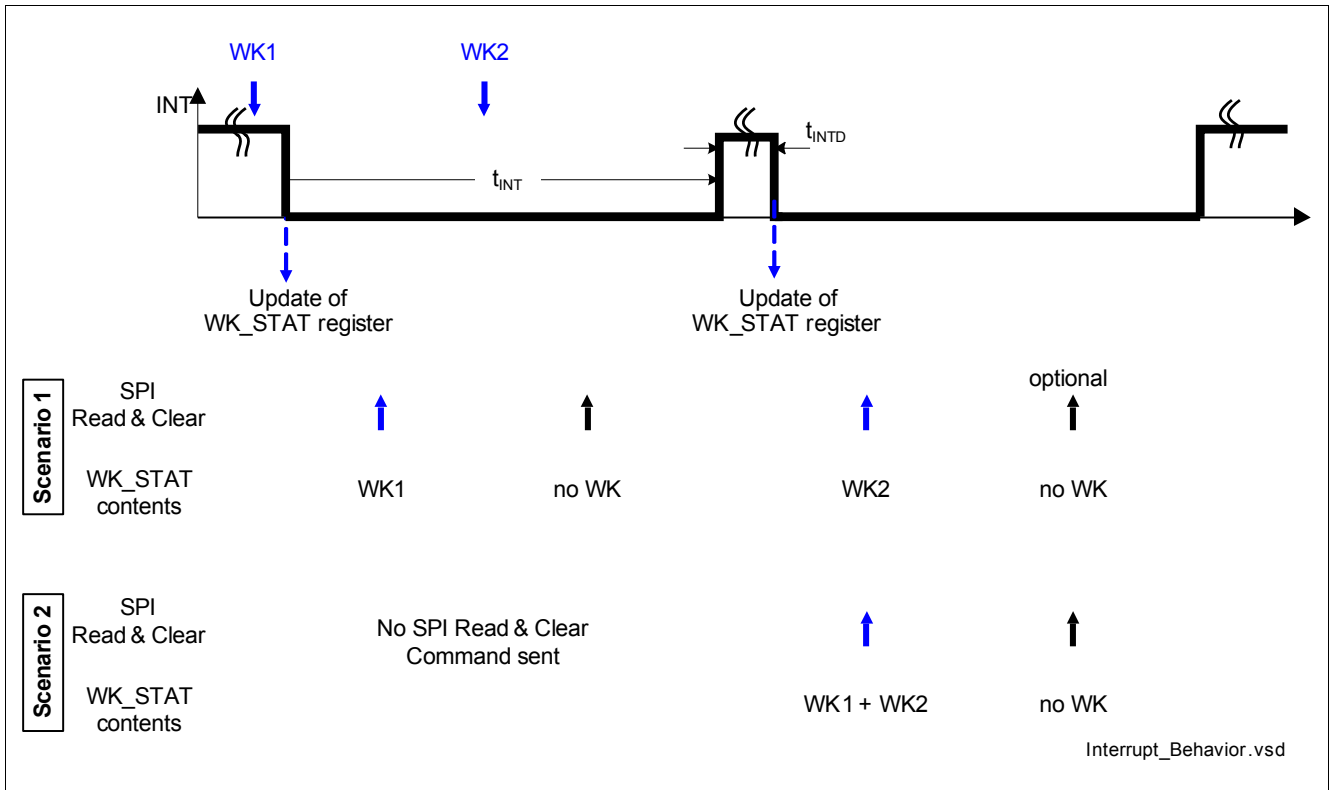


Figure 43 Interrupt Signalization Behavior

## Interrupt Function

### 13.2 Electrical Characteristics

**Table 24 Electrical Characteristics**

$V_S = 5.5\text{ V to }28\text{ V}$ ;  $T_j = -40\text{ °C to }+150\text{ °C}$ ; SBC Normal Mode; all voltages with respect to ground; positive current defined flowing into pin; unless otherwise specified.

Parameter	Symbol	Values			Unit	Note or Test Condition	Number
		Min.	Typ.	Max.			
<b>Interrupt Output; Pin INT</b>							
INT High Output Voltage	$V_{INT,H}$	$0.8 \times V_{CC1}$	–	–	V	<sup>1)</sup> $I_{INT} = -1\text{ mA}$ ; INT = OFF	P_13.2.1
INT Low Output Voltage	$V_{INT,L}$	–	–	$0.2 \times V_{CC1}$	V	<sup>1)</sup> $I_{INT} = 1\text{ mA}$ ; INT = ON	P_13.2.2
INT Pulse Width	$t_{INT}$	80	100	120	$\mu\text{s}$	<sup>2)</sup>	P_13.2.3
INT Pulse Minimum Delay Time	$t_{INTD}$	80	100	120	$\mu\text{s}$	<sup>2)</sup> between consecutive pulses	P_13.2.4
<b>Configuration Select; Pin INT</b>							
Config Pull-down Resistance	$R_{CFG}$	180	250	350	$\text{k}\Omega$	$V_{INT} = 3.3\text{ V}$	P_13.2.5
Config Select Filter Time	$t_{CFG\_F}$	5	10	14	$\mu\text{s}$		P_13.2.6

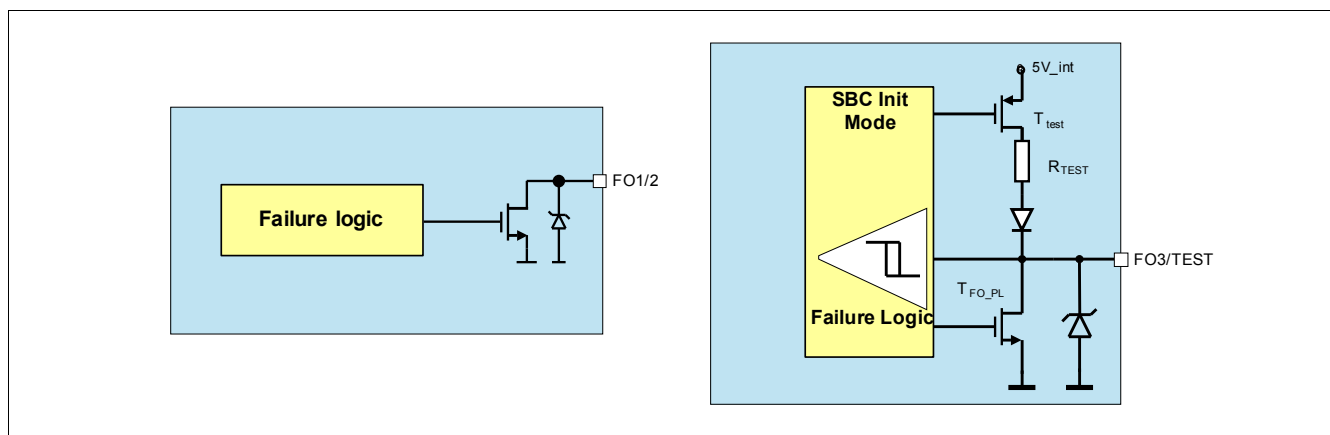
1) Output Voltage Value also determines device configuration during SBC Init Mode

2) Not subject to production test, tolerance defined by internal oscillator tolerance.

## Fail Outputs

# 14 Fail Outputs

## 14.1 Block and Functional Description



**Figure 44** Simplified Fail Output Block Diagram for FO1/2 and for FO3/TEST

The fail outputs consist of a failure logic block and three open-drain outputs (FO1, FO2, FO3) with active-low signalization.

The fail outputs are activated due to following failure conditions:

- Watchdog trigger failure (For config 3&4 only after the 2nd watchdog trigger failure and for config 1&2 after 1st watchdog trigger failure)
- Thermal shutdown TSD2
- VCC1 short to GND
- VCC1 overvoltage (only if the SPI bit **VCC1\_OV\_RST** is set)
- After 4 consecutive VCC1 undervoltage event (see [Chapter 15.6](#) for details)

At the same time SBC Fail-Safe Mode is entered (exceptions are watchdog trigger failures depending on selected configurations - see [Chapter 5.1.1](#)).

The fail output activation is signalled in the SPI bit **FAILURE** of the register **DEV\_STAT**.

For testing purposes only the Fail Outputs can also be activated via SPI by setting the bit **FO\_ON**. This bit is independent of the FO failure bits. In case that there is no failure condition, the FO outputs can also be turned off again via SPI, i.e. no successful watchdog trigger is needed.

The entry of SBC Fail-Safe Mode due to a watchdog failure can be configured as described in [Chapter 5.1.1](#).

In order to deactivate the fail outputs in SBC Normal Mode the failure conditions must not be present anymore (e.g. TSD2, VCC1 short circuit, etc) and the bit **FAILURE** needs to be cleared via SPI command.

In case of a watchdog failure the correct procedure to deactivate the fail outputs is:

- a successful WD trigger, i.e. **WD\_FAIL** must be cleared
- clearing of the **FAILURE** bit

**WD\_FAIL** will also be cleared when going to SBC Sleep or SBC Fail-Safe Mode due to another failure (not a WD failure) or if the watchdog is disabled in SBC Stop Mode

## Fail Outputs

*Note:* The Fail output pin is triggered for any of the above described failures. No FAILURE is caused for the 1st watchdog failure if selected for Config2.

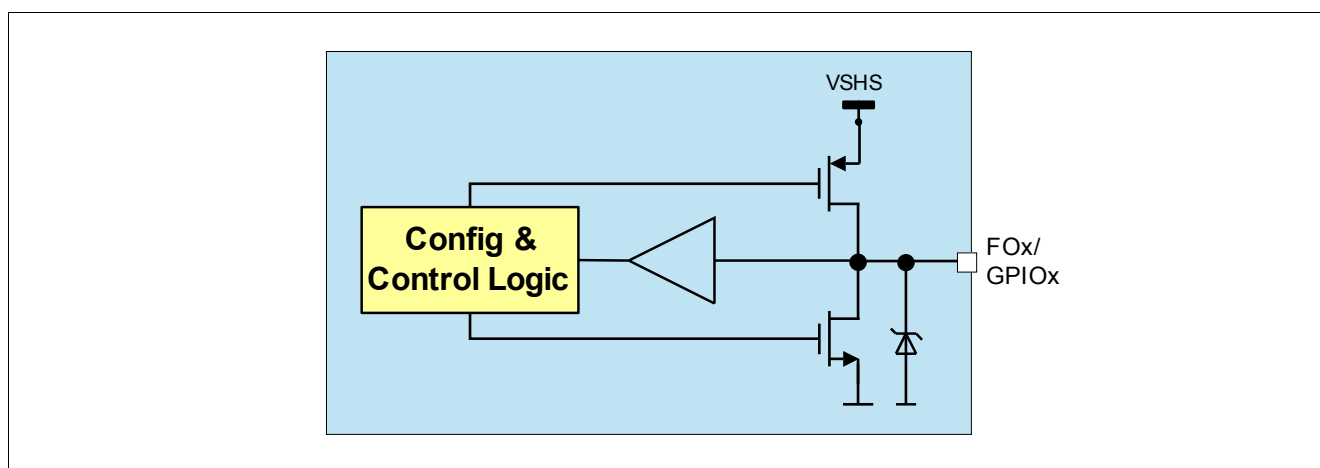
The three fail outputs are activated simultaneously with following output functionalities:

- FO1: Static fail output
- FO2: 1.25Hz, 50% (typ.) duty cycle, e.g. to generate an indicator signal
- FO3: 100Hz PWM, 20% (typ.) duty cycle, e.g. to generate a dimmed rear light from a break light.

*Note:* The duty cycle for FO3 can be configured via SPI option to 20%, 10%, 5% or 2.5%. Default value is 20%. See the register **FO\_DC** for configuration.

### 14.1.1 General Purpose I/O Functionality of FO2 and FO3 as Alternate Function

In case that FO2 and FO3 are not used in the application, those pins can also be configured with an alternate function as high-voltage (VSHS related) General Purpose I/O pins.



**Figure 45** Simplified General Purpose I/O block diagram for FO2 and FO3/TEST

The pins are by default configured as FO pins. The configuration is done via the SPI register **GPIO\_CTRL**. The alternate function can be:

- Wake Inputs: The detection threshold  $V_{GPIO,th}$  is similar as for the WK inputs. The wake-up detection behavior is the same as for WKx pins. Wake events are stored and reported in **WK\_STAT\_2**.
- Low-Side Switches: The switch is able to drive currents of up to 10mA (see also  $V_{GPIO,L1}$ ). It is self-protected with regards to current limitation. No other diagnosis is implemented.
- High-Side Switches: The switch is able to drive currents up to 10mA (see also  $V_{GPIO,H1}$ ). It is self-protected with regards to current limitation. No other diagnosis is implemented.
- If configured as GPIO then the respective level at the pin will be shown in **WK\_LVL\_STAT** in SBC Normal and Stop Mode. This is also the case if configured as LS/HS and can serve as a feedback about the respective state. GPIO2 is shared with the TEST level bit.

**Table 25** describes the behavior of the FO/GPIO pins in their different configurations and SBC modes.

## Fail Outputs

**Table 25 Fail-Output and GPIO configuration behavior during the respective SBC Modes**

FOx Configuration	SBC Normal Mode	SBC Stop Mode	SBC Sleep Mode	SBC Restart Mode	SBC Fail-Safe Mode
FOx (default)	configurable	fixed	fixed	active / fixed	active
OFF		OFF	OFF	OFF	OFF
Wake Input		wake capable	wake capable	wake capable	OFF
Low-Side		fixed	fixed	OFF	OFF
High-Side		fixed	fixed	OFF	OFF

### Explanation of FO/GPIO states:

- configurable: settings can be changed in this SBC mode
- fixed: settings stay as configured in SBC Normal Mode
- active: FOx is activated due to a failure leading to SBC Restart or Fail-Safe Mode.

### Restart Behavior:

The behavior during SBC Restart and Fail-Safe Mode as well as the transition to SBC Normal Mode is as follows:

- if configured as Wake Input: it will stay wake capable during SBC Restart Mode and OFF while in SBC Fail-Safe Mode. It will resume wake capability when leaving SBC Restart Mode (SPI register is not modified)
- if configured as Low-Side or High-Side: They will be disabled during SBC Restart and Fail-Safe Mode. After leaving SBC Restart Mode the previously configured function will be resumed (SPI register is not modified)
- if configured as FO and activated due to a failure: FO will stay activated during SBC Restart Mode and when entering SBC Normal Mode (SPI register is not modified)

*Note: In order to avoid unintentional entry of SBC Development Mode care must be taken that the level of FO3/TEST is HIGH during device power up and SBC Init Mode.*

*Note: The FOx drivers are supplied via VS. However, the GPIO HS switches (FO2, FO3/TEST) are supplied by VSHS*

## Fail Outputs

## 14.2 Electrical Characteristics

Table 26 Electrical Characteristics

$V_{SHS} = 5.5\text{ V to }28\text{ V}$ ;  $T_j = -40\text{ }^\circ\text{C to }+150\text{ }^\circ\text{C}$ ; SBC Normal Mode; all voltages with respect to ground; positive current defined flowing into pin; unless otherwise specified.<sup>1)</sup>

Parameter	Symbol	Values			Unit	Note or Test Condition	Number
		Min.	Typ.	Max.			
<b>Pin FO1</b>							
FO1 low output voltage (active)	$V_{FO,L1}$	–	–	1.0	V	$I_{FO} = 4\text{ mA}$	P_14.2.1
FO1 high output current (inactive)	$I_{FO,H}$	0	–	2	$\mu\text{A}$	$V_{FO} = 28\text{ V}$	P_14.2.2
<b>Pin FO2</b>							
FO2 side indicator frequency	$f_{FO2SI}$	1.00	1.25	1.50	Hz	<sup>3)</sup>	P_14.2.3
FO2 side indicator duty cycle	$d_{FO2SI}$	45	50	55	%	<sup>3)</sup>	P_14.2.4
<b>Pin FO3/TEST<sup>2)</sup></b>							
Pull-up Resistance at pin FO3/TEST	$R_{TEST}$	2.5	5	10	k $\Omega$	$V_{TEST} = 0\text{ V}$ ; SBC Init Mode	P_14.2.5
TEST Input Filter Time	$t_{TEST}$	50	64	80	$\mu\text{s}$	<sup>3)</sup>	P_14.2.6
FO3 pulsed light frequency	$f_{FO3PL}$	80	100	120	Hz	<sup>3)</sup>	P_14.2.7
FO3 pulsed light duty cycle	$d_{FO3PL}$	16	20	24	%	<sup>3)4)</sup> default setting	P_14.2.8

**Alternate FO2...3****Electrical Characteristics: GPIO**

GPIO low-side output voltage (active)	$V_{GPIO,L1}$	–	–	1	V	$I_{GPIO} = 10\text{ mA}$	P_14.2.9
GPIO low-side output voltage (active)	$V_{GPIO,L2}$	–	–	5	mV	<sup>5)</sup> $I_{GPIO} = 50\text{ }\mu\text{A}$	P_14.2.17
GPIO high-side output voltage (active)	$V_{GPIO,H1}$	VSHS-1	–	–	V	$I_{GPO} = -10\text{ mA}$	P_14.2.10
GPIO high-side output voltage (active)	$V_{GPIO,H2}$	VSHS-5	–	–	mV	<sup>5)</sup> $I_{GPO} = -50\text{ }\mu\text{A}$	P_14.2.18
GPIO input threshold voltage	$V_{GPIO,th}$	1.5	2.5	3.5	V	<sup>6)</sup> hysteresis included	P_14.2.11
GPIO input threshold hysteresis	$V_{GPIO,hys}$	100	400	700	mV	<sup>5)</sup>	P_14.2.12
GPIO low-side current limitation	$I_{GPIO,max}$	10	–	30	mA	$V_{GPIO} = 28\text{ V}$	P_14.2.13
GPIO high-side current limitation	$I_{GPIO,max}$	-45	–	-10	mA	$V_{GPIO} = 0\text{ V}$	P_14.2.14



---

## Fail Outputs

- 1) The FOx drivers are supplied via VS. However, the GPIO HS switches (FO2, FO3/TEST) are supplied by VSHS
- 2) The external capacitance on this pin must be limited to less than 10nF to ensure proper detection of SBC Development Mode and SBC User Mode operation.
- 3) Not subject to production test, tolerance defined by internal oscillator tolerance.
- 4) The duty cyclic is adjustable via the SPI bits **FO\_DC**.
- 5) Not subject to production test, specified by design.
- 6) Applies also for TEST voltage input level

## 15 Supervision Functions

### 15.1 Reset Function

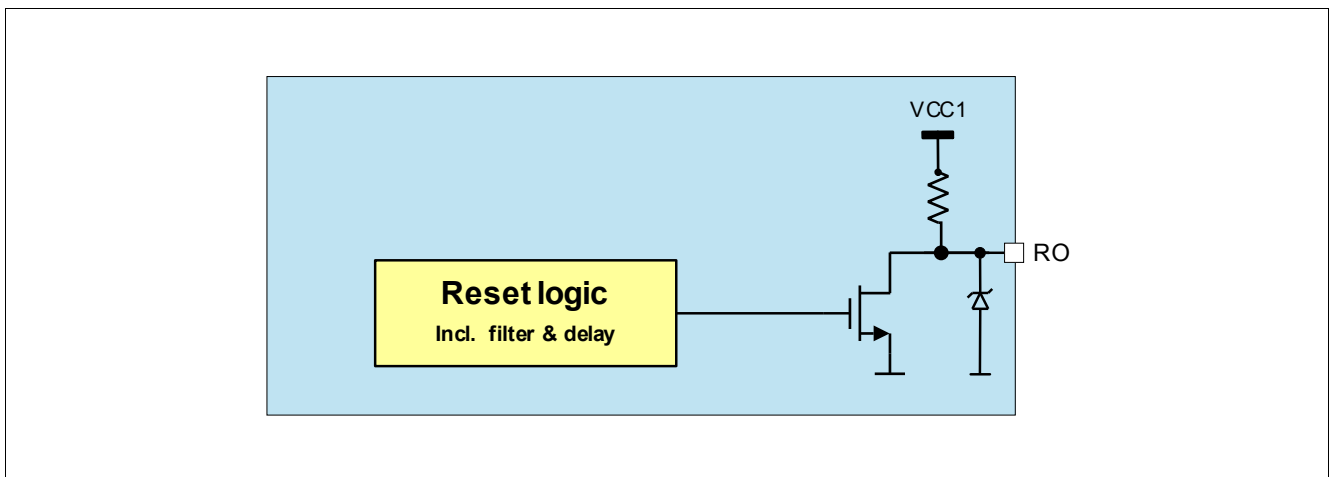


Figure 46 Reset Block Diagram

#### 15.1.1 Reset Output Description

The reset output pin RO provides a reset information to the microcontroller, for example, in the event that the output voltage has fallen below the undervoltage threshold  $V_{RT1/2/3/4}$ . In case of a reset event, the reset output RO is pulled to low after the filter time  $t_{RF}$  and stays low as long as the reset event is present plus a reset delay time  $t_{RD1}$ . When connecting the SBC to battery voltage, the reset signal remains LOW initially. When the output voltage  $V_{CC1}$  has reached the reset default threshold  $V_{RT1,r}$ , the reset output RO is released to HIGH after the reset delay time  $t_{RD1}$ . A reset can also occur due to a watchdog trigger failure. The reset threshold can be adjusted via SPI, the default reset threshold is  $V_{RT1,f}$ . The RO pin has an integrated pull-up resistor. In case reset is triggered, it will be pulled low for  $V_{CC1} \geq 1V$  and for  $V_S \geq V_{POR,f}$  (see also [Chapter 15.3](#)).

The timings for the RO triggering regarding VCC1 undervoltage and watchdog trigger is shown in [Figure 47](#).

Supervision Functions

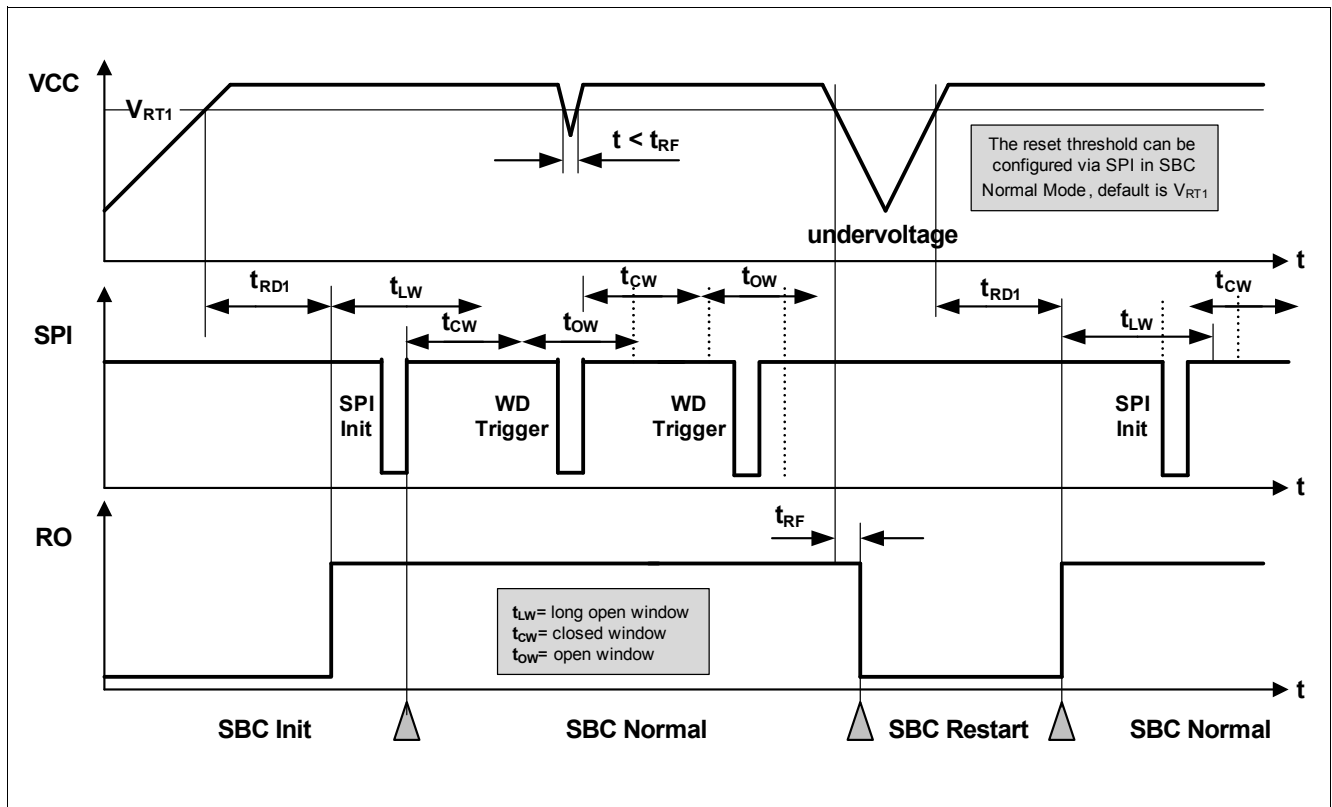


Figure 47 Reset Timing Diagram

15.1.2 Soft Reset Description

In SBC Normal and SBC Stop Mode, it is also possible to trigger a device internal reset via a SPI command in order to bring the SBC into a defined state in case of failures. In this case the microcontroller must send a SPI command and set the **MODE** bits to '11' in the **M\_S\_CTRL** register. As soon as this command becomes valid, the SBC is set back to SBC INIT Mode and all SPI registers are set to their default values (see SPI [Chapter 16.5](#) and [Chapter 16.6](#)).

Two different soft reset configurations are possible via the SPI bit **SOFT\_RESET\_RO**:

- The reset output (RO) is triggered when the soft reset is executed (default setting, the same reset delay time  $t_{RD1}$  applies)
- The reset output (RO) is not triggered when the soft reset is executed

*Note:* The device must be in SBC Normal Mode or SBC Stop Mode when sending this command. Otherwise, the command will be ignored.

## Supervision Functions

### 15.2 Watchdog Function

The watchdog is used to monitor the software execution of the microcontroller and to trigger a reset if the microcontroller stops serving the watchdog due to a lock up in the software.

Two different types of watchdog functions are implemented and can be selected via the bit **WD\_WIN**:

- Time-Out Watchdog (default value)
- Window Watchdog

The respective watchdog functions can be selected and programmed in SBC Normal Mode. The configuration stays unchanged in SBC Stop Mode.

Please refer to **Table 27** to match the SBC Modes with the respective watchdog modes.

**Table 27 Watchdog Functionality by SBC Modes**

SBC Mode	Watchdog Mode	Remarks
INIT Mode	Starts with Long Open Window	Watchdog starts with Long Open Window after RO is released
Normal Mode	WD Programmable	Window Watchdog, Time-Out watchdog or switched OFF for SBC Stop Mode
Stop Mode	Watchdog is fixed or OFF	
Sleep Mode	OFF	SBC will start with Long Open Window when entering SBC Normal Mode.
Restart Mode	OFF	SBC will start with Long Open Window when entering SBC Normal Mode.

The watchdog timing is programmed via SPI command. As soon as the watchdog is programmed, the timer starts with the new setting and the watchdog must be served. The watchdog is triggered by sending a valid SPI-write command to the watchdog configuration register. The trigger SPI command is executed when the Chip Select input (CSN) becomes HIGH.

When coming from SBC Init, SBC Restart Mode or in certain cases from SBC Stop Mode, the watchdog timer is always started with a long open window. The long open window ( $t_{LW} = 200\text{ms}$ ) allows the microcontroller to run its initialization sequences and then to trigger the watchdog via SPI.

The watchdog timer period can be selected via the watchdog timing bit field (**WD\_TIMER**) and is in the range of 10 ms to 1000 ms. This setting is valid for both watchdog types.

The following watchdog timer periods are available:

- WD Setting 1: 10ms
- WD Setting 2: 20ms
- WD Setting 3: 50ms
- WD Setting 4: 100ms
- WD Setting 5: 200ms
- WD Setting 6: 500ms
- WD Setting 7: 1000ms

In case of a watchdog reset, SBC Restart or SBC Fail-Safe Mode is entered according to the configuration and the SPI bits **WD\_FAIL** are set. Once the RO goes HIGH again the watchdog immediately starts with a long open window the SBC enters automatically SBC Normal Mode.

In SBC Development Mode the watchdog is OFF and therefore no reset and interrupt are generated due to a watchdog failure.

## Supervision Functions

Depending on the configuration, the **WD\_FAIL** bits will be set after a watchdog trigger failure as follows:

- In case an incorrect WD trigger is received (triggering in the closed watchdog window or when the watchdog counter expires without a valid trigger) then the **WD\_FAIL** bits will be increased (showing the number of incorrect WD triggers)
- For config 2: the bits can have the maximum value of '01'
- For config 1, 3 and 4: the bits can have the maximum value of '10'

The **WD\_FAIL** bits are cleared automatically when following conditions apply:

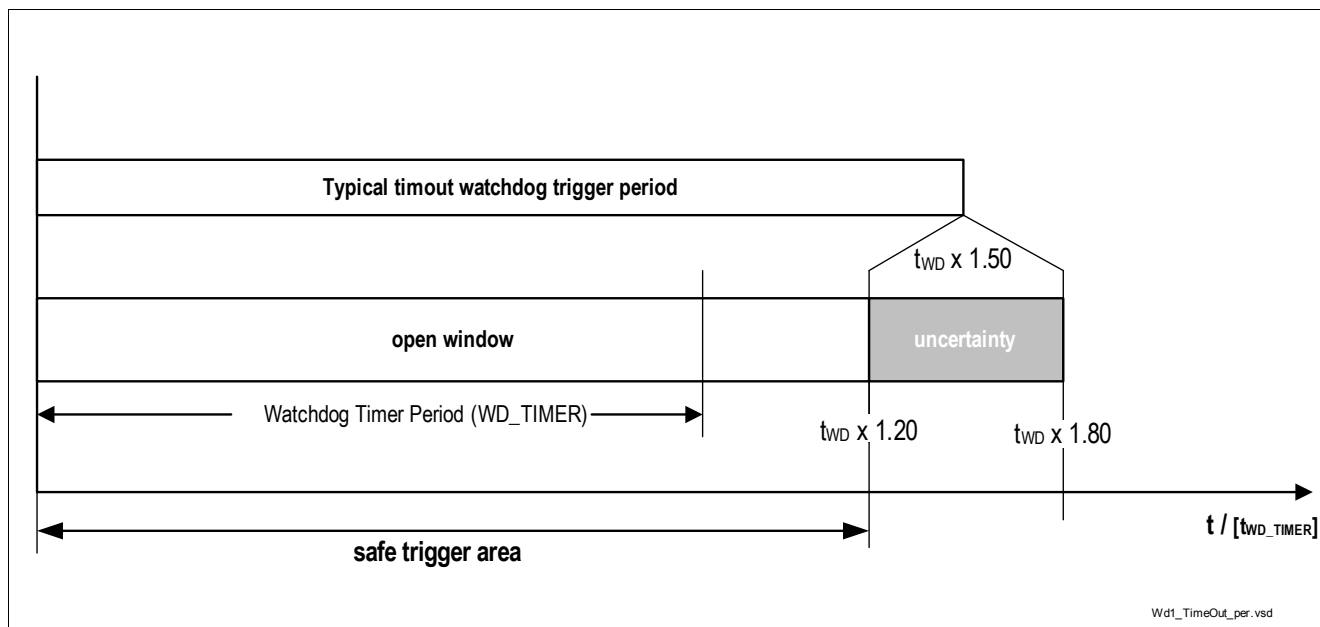
- After a successful watchdog trigger
- When the watchdog is OFF: in SBC Stop Mode after successfully disabling it, in SBC Sleep Mode, or in SBC Fail-Safe Mode (except for a watchdog failure)

### 15.2.1 Time-Out Watchdog

The time-out watchdog is an easier and less secure watchdog than a window watchdog as the watchdog trigger can be done at any time within the configured watchdog timer period.

A correct watchdog service immediately results in starting a new watchdog timer period. Taking the tolerances of the internal oscillator into account leads to the safe trigger area as defined in **Figure 48**.

If the time-out watchdog period elapses, a watchdog reset is created by setting the reset output RO low and the SBC switches to SBC Restart or SBC Fail-Safe Mode.



**Figure 48** Time-out Watchdog Definition

Supervision Functions

15.2.2 Window Watchdog

Compared to the time-out watchdog the characteristic of the window watchdog is that the watchdog timer period is divided between an closed and an open window. The watchdog must be triggered within the open window.

A correct watchdog trigger results in starting the window watchdog period by a closed window followed by an open window.

The watchdog timer period is at the same time the typical trigger time and defines the middle of the open window. Taking the oscillator tolerances into account leads to a safe trigger area of:

$$t_{WD} \times 0.72 < \text{safe trigger area} < t_{WD} \times 1.20.$$

The typical closed window is defined to a width of 60% of the selected window watchdog timer period. Taking the tolerances of the internal oscillator into account leads to the timings as defined in **Figure 49**.

A correct watchdog service immediately results in starting the next closed window.

Should the trigger signal meet the closed window or should the watchdog timer period elapse, then a watchdog reset is created by setting the reset output RO low and the SBC switches to SBC Restart or SBC Fail-Safe Mode.

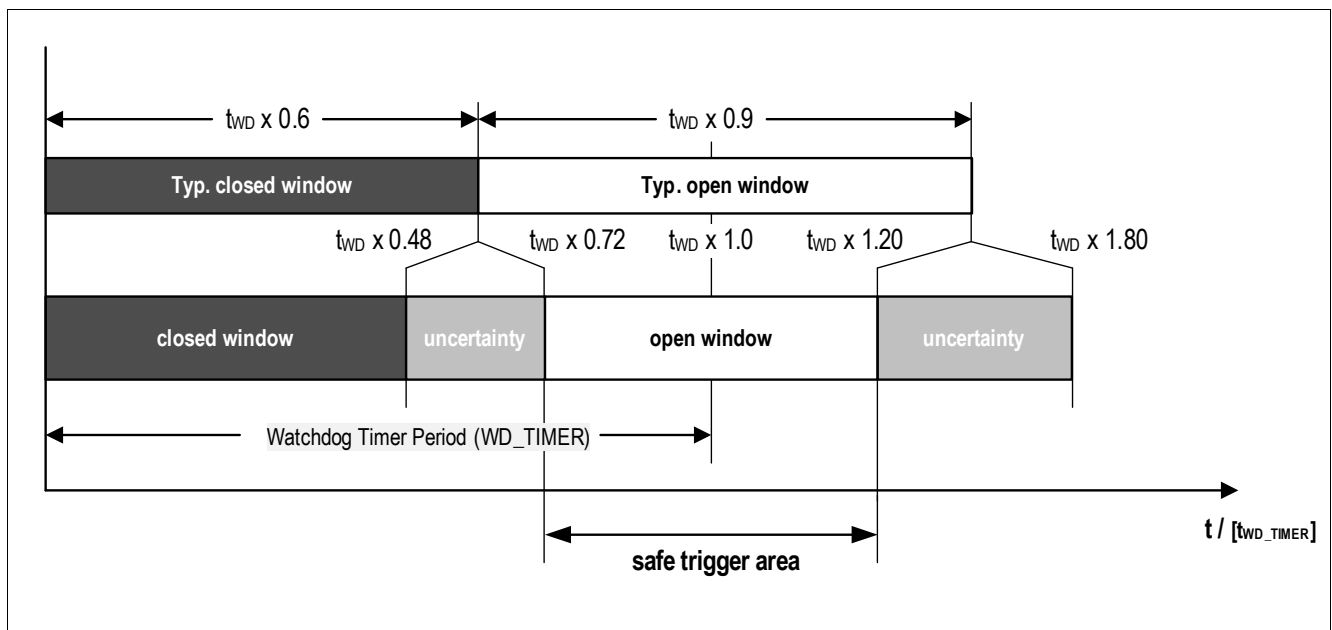


Figure 49 Window Watchdog Definition

---

**Supervision Functions****15.2.3 Watchdog Setting Check Sum**

A check sum bit is part of the SPI command to trigger the watchdog and to set the watchdog setting.

The sum of the 8 data bits in the register WWD\_CTRL needs to have even parity (see **Equation (15.1)**). This is realized by either setting the bit **CHECKSUM** to 0 or 1. If the check sum is wrong, then the SPI command is ignored, i.e. the watchdog is not triggered or the settings are not changed and the bit SPI\_FAIL is set.

The checksum is calculated by taking all 8 data bits into account. The written value of the reserved bit 3 of the WWD\_CTRL register is considered (even if read as '0' in the SPI output) for checksum calculation, i.e. if a 1 is written on the reserved bit position, then a 1 will be used in the checksum calculation.

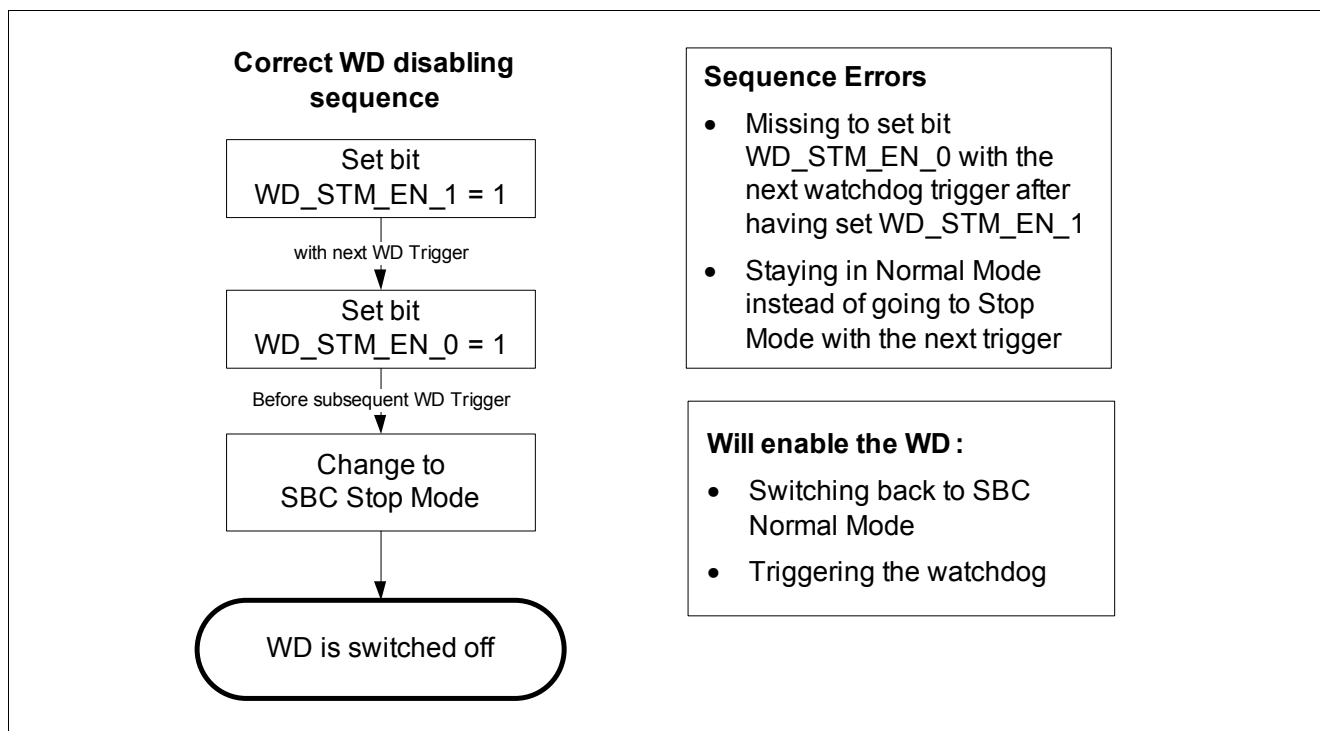
(15.1)

$$\text{CHKSUM} = \text{Bit15} \oplus \dots \oplus \text{Bit8}$$

## Supervision Functions

### 15.2.4 Watchdog during SBC Stop Mode

The watchdog can be disabled for SBC Stop Mode in SBC Normal Mode. For safety reasons, there is a special sequence to be followed in order to disable the watchdog as described in [Figure 50](#). Two different SPI bits ([WD\\_STM\\_EN\\_0](#), [WD\\_STM\\_EN\\_1](#)) in the registers [WK\\_CTRL\\_1](#) and [WD\\_CTRL](#) need to be set.



**Figure 50 Watchdog disabling sequence in SBC Stop Mode**

If a sequence error occurs, then the bit [WD\\_STM\\_EN\\_1](#) will be cleared and the sequence has to be started again.

The watchdog can be enabled by triggering the watchdog in SBC Stop Mode or by switching back to SBC Normal Mode via SPI command. In both cases the watchdog will start with a long open window and the bits [WD\\_STM\\_EN\\_1](#) and [WD\\_STM\\_EN\\_0](#) are cleared. After the long open window the watchdog has to be served as configured in the [WD\\_CTRL](#) register.

*Note: The bit [WD\\_STM\\_EN\\_0](#) will be cleared automatically when the sequence is started and it was 1 before.*



---

## Supervision Functions

### 15.2.5 Watchdog Start in SBC Stop Mode due to Bus Wake

In SBC Stop Mode the Watchdog can be disabled. In addition a feature is available which will start the watchdog with any BUS wake (CAN or LIN) during SBC Stop Mode. The feature is enabled by setting the bit **WD\_EN\_WK\_BUS** = 1

(= default value after POR). The bit can only be changed in SBC Normal Mode and needs to be programmed before starting the watchdog disable sequence.

A wake on CAN and LINx will generate an interrupt and the RXD pin for LINx or CAN is pulled to low. By these signals the microcontroller is informed that the watchdog is started with a long open window. After the long open window the watchdog has to be served as configured in the **WD\_CTRL** register.

To disable the watchdog again, the SBC needs to be switched to Normal Mode and the sequence needs to be sent again.

Supervision Functions

15.3 VS Power On Reset

At power up of the device, the VS Power on Reset is detected when  $V_S > V_{POR,r}$  and the SPI bit **POR** is set to indicate that all SPI registers are set to POR default settings. VCC1 is starting up and the reset output will be kept LOW and will only be released once VCC1 has crossed  $V_{RT1,r}$  and after  $t_{RD1}$  has elapsed. In case  $V_S < V_{POR,f}$  an device internal reset will be generated and the SBC is switched OFF and will restart in INIT mode at the next VS rising. This is shown in **Figure 51**.

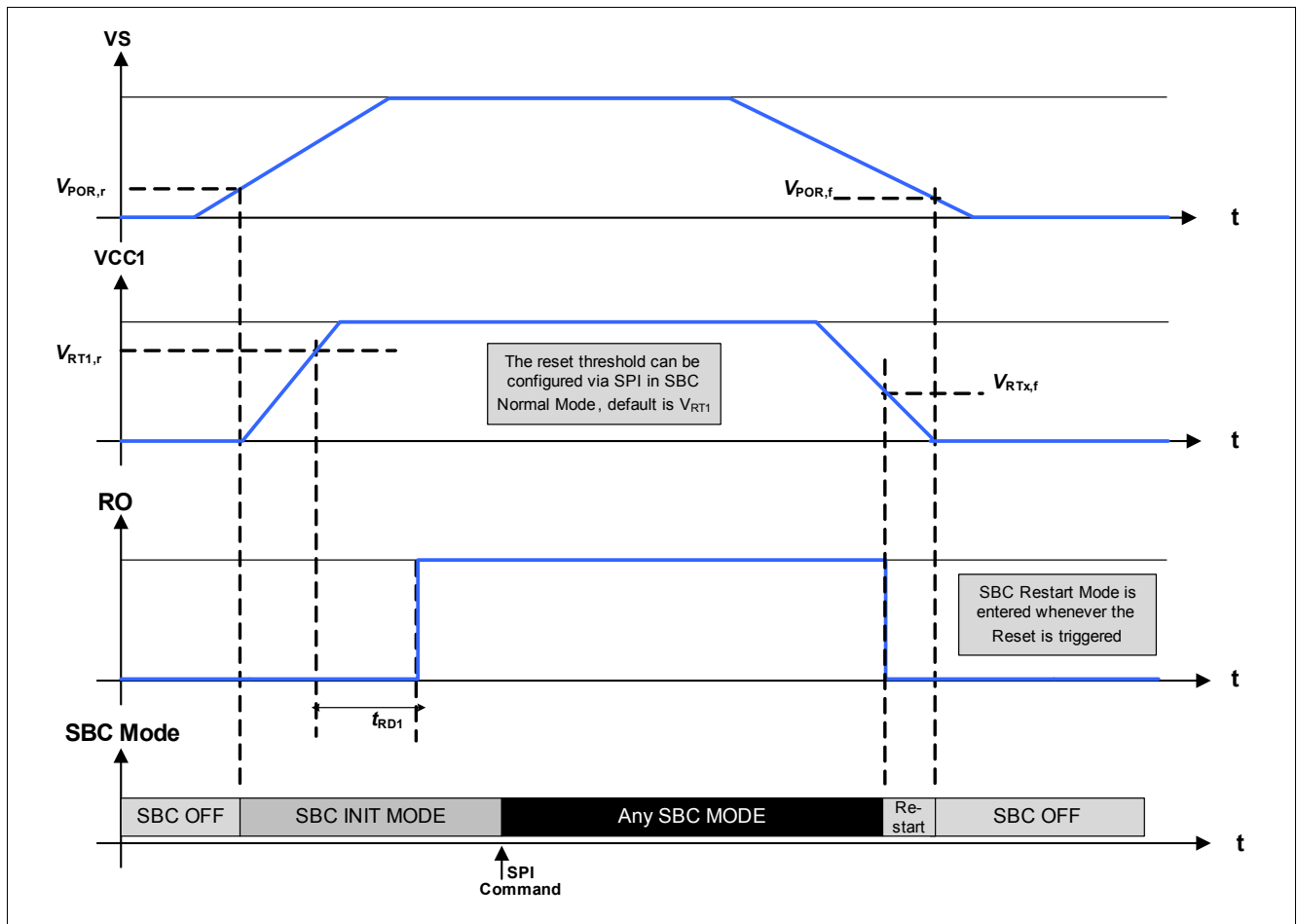


Figure 51 Ramp up / down example of Supply Voltage

## Supervision Functions

### 15.4 Undervoltage VS and VSHS

If the supply voltage VS reaches the undervoltage threshold  $V_{S,UV}$  then the SBC does the following measures:

- SPI bit **VS\_UV** is set. No other error bits are set. The bit can be cleared once the condition is not present anymore,
- VCC3 is disabled (see [Chapter 8.2](#)) unless the control bit **VCC3\_VS\_UV\_OFF** is set
- The VCC1 short circuit protection becomes inactive (see [Chapter 15.7](#)). However, the thermal protection of the device remains active.

If the undervoltage threshold is exceeded (VS rising) then functions will be automatically enabled again.

If the supply voltage VSHS passes below the undervoltage threshold ( $V_{SHS,UV}$ ) the SBC does the following measures:

- HS1...4 are acting accordingly to the SPI setting (see [Chapter 9](#))
- LINx: Transmitter and Receiver are disabled during the VSHS undervoltage condition (see [Chapter 11.2.7](#));
- SPI bit **VSHS\_UV** is set. No other error bits are set. The bit can be cleared once the condition is not present anymore,
- VCC1, VCC2, WKx and CAN are not affected by VSHS undervoltage

### 15.5 Overvoltage VSHS

If the supply voltage VSHS reaches the overvoltage threshold ( $V_{SHS,OVD}$ ) the SBC triggers the following measures:

- HS1...4 are acting accordingly to the SPI setting (see [Chapter 9](#))
- SPI bit **VSHS\_OV** is set. No other error bits are set. The bit can be cleared once the condition is not present anymore,
- VCC1, VCC2, VCC3, WKx, LIN and CAN are not affected by VS overvoltage

## 15.6 VCC1 Over-/ Undervoltage and Undervoltage Prewarning

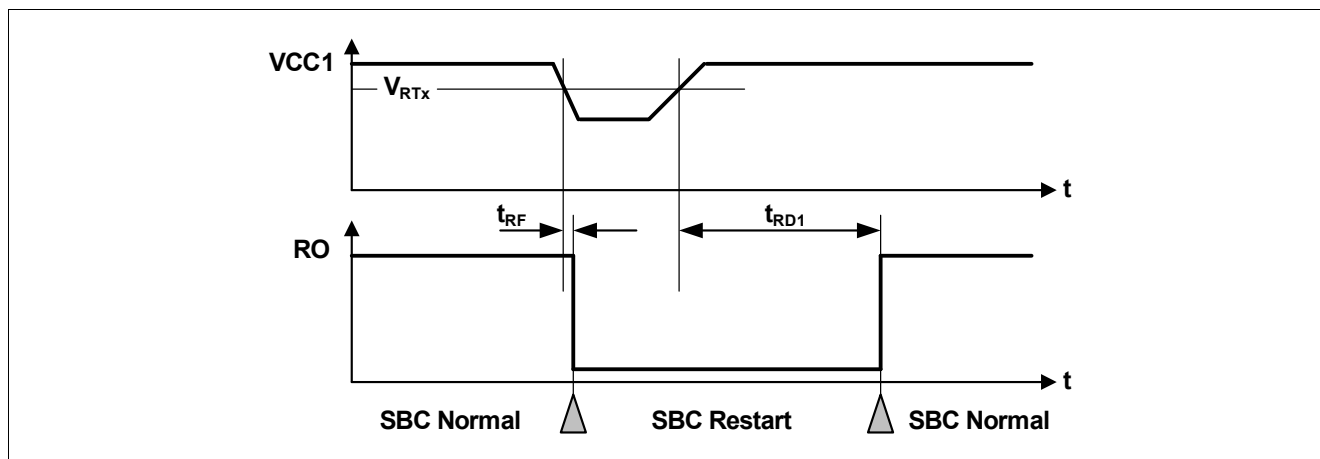
### 15.6.1 VCC1 Undervoltage and Undervoltage Prewarning

A first-level voltage detection threshold is implemented as a prewarning for the microcontroller. The prewarning event is signaled with the bit **VCC1\_WARN**. No other actions are taken.

As described in [Chapter 15.1](#) and [Figure 52](#), a reset will be triggered (RO pulled 'low') when the  $V_{CC1}$  output voltage falls below the selected undervoltage threshold ( $V_{RTX}$ ). The bit **VCC1\_UV** is set and the SBC will enter SBC Restart Mode.

*Note:* The **VCC1\_WARN** or **VCC1\_UV** bits are not set in Sleep Mode as  $V_{CC1} = 0V$  in this case

## Supervision Functions



**Figure 52 VCC1 Undervoltage Timing Diagram**

An additional safety mechanism is implemented to avoid repetitive VCC1 undervoltage resets due to high dynamic loads on VCC1:

- A counter is increased for every consecutive VCC1 undervoltage event (regardless on the selected reset threshold),
- The counter is active in SBC Init-, Normal-, and Stop Mode,
- For  $V_S < V_{S,UV}$  the counter will be stopped in SBC Normal Mode (i.e. the VS UV comparator is always enabled in SBC Normal Mode),
- A 4th consecutive VCC1 undervoltage event will lead to SBC Fail-Safe Mode entry and to setting the bit **VCC1\_UV\_FS**
- This counter is cleared:
  - when SBC Fail-Safe Mode is entered,
  - when the bit **VCC1\_UV** is cleared,
  - when a Soft Reset is triggered.

*Note: It is recommended to clear the VCC1\_UV bit once it was set and detected.*

### 15.6.2 VCC1 Overvoltage

For fail-safe reasons a configurable VCC1 overvoltage detection feature is implemented for SBC Init- and Normal Mode.

In case the  $V_{CC1,OV,r}$  threshold is crossed, the SBC triggers following measures depending on the configuration:

- The bit **VCC1\_OV** is always set;
- If the bit **VCC1\_OV\_RST** is set and **CFGP** = '1', then SBC Restart Mode is entered. The FOx outputs are activated. After the reset delay time ( $t_{RD1}$ ), the SBC Restart Mode is left and SBC Normal Mode is resumed even if the VCC1 overvoltage event is still present (see also **Figure 53**). The **VCC1\_OV\_RST** bit is cleared automatically;
- If the bit **VCC1\_OV\_RST** is set and **CFGP** = '0', then SBC Fail-Safe Mode is entered and FOx outputs are activated.

*Note: Before entering SBC Stop Mode the bit **VCC1\_OV\_RST** must be set to '0' to avoid unintentional SBC Restart or Fail-Safe Mode entry. The status bit **VCC1\_OV** could be set unintentionally. The reason is*

## Supervision Functions

that external noise could be coupled into the VCC1 supply line. Especially, in case the VCC1 output current in SBC STOP Mode is below the active peak threshold ( $I_{VCC1, I_{peak}}$ ).

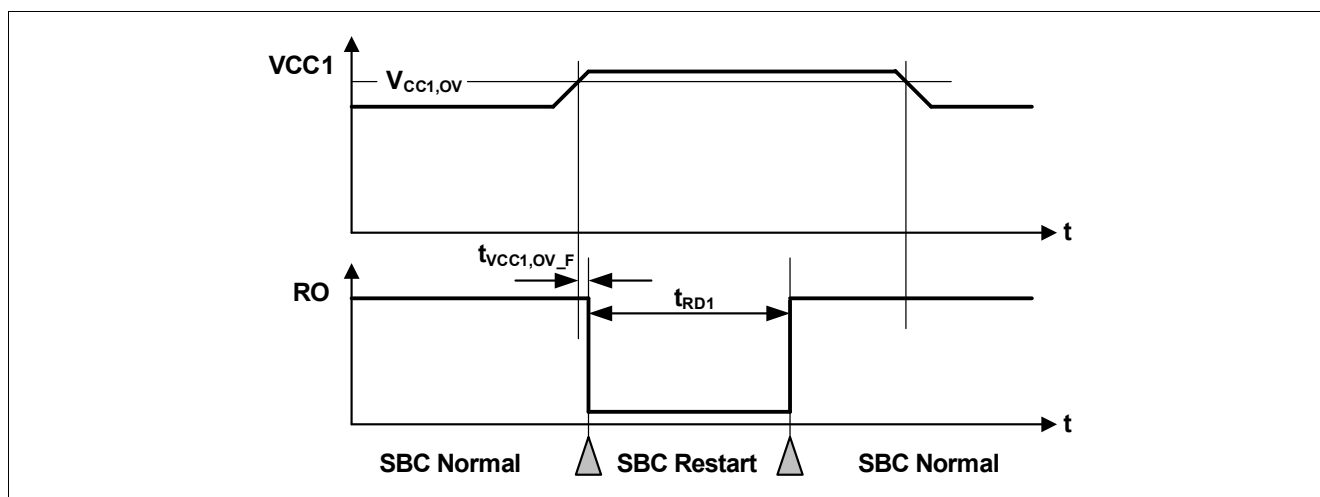


Figure 53 VCC1 Overvoltage Timing Diagram

### 15.7 VCC1 Short Circuit and VCC3 Diagnostics

The short circuit protection feature for  $V_{CC1}$  is implemented as follows ( $V_S$  needs to be higher than  $V_{S,UV}$ ):

- If VCC1 is not above the  $V_{RTX}$  within  $t_{VCC1,SC}$  after device power up or after waking from SBC Sleep Mode then the SPI bit **VCC1\_SC** bit is set, VCC1 is turned OFF, the FOx pins are enabled, **FAILURE** is set and SBC Fail-Safe Mode is entered. The SBC can be activated again via wake on CAN, LINx, WKx.
- The same behavior applies, if  $V_{CC1}$  falls below  $V_{RTX}$  for longer than  $t_{VCC1,SC}$ .

VCC3 diagnosis features are implemented as follows:

- Load Sharing: The external PNP is disabled when  $V_S < V_{S,UV}$  if  $VCC3\_VS\_UV\_OFF = 0$  or when in SBC Stop Mode if **VCC3\_LS\_STP\_ON** = '0'. All other diagnostic features are disabled because they are provided via VCC1.
- Stand-alone configuration: The external PNP is disabled when  $VCC3 < V_{S,UV}$  if  $VCC3\_VS\_UV\_OFF = 0$ . The overcurrent limitation is signalled via the bit **VCC3\_OC** according to the selected shunt resistor, VCC3 undervoltage is signalled via the bit **VCC3\_UV** and the regulator is disabled due to  $V_S$  undervoltage when  $V_{S,UV}$  is reached.

Note: Neither **VCC1\_SC** nor **VCC3\_UV** flags are set during power up of  $V_{CC1}$  or turn on of  $V_{CC3}$  respectively.

### 15.8 VCC2 Undervoltage and VCAN Undervoltage

An undervoltage warning is implemented for VCC2 and VCAN as follows:

- $V_{CC2}$  undervoltage Detection: In case  $V_{CC2}$  will drop below the  $V_{CC2,UV,f}$  threshold, then the SPI bit **VCC2\_UV** is set and can be only cleared via SPI.
- $V_{CAN}$  undervoltage Detection: In case the voltage on  $V_{CAN}$  will drop below the  $V_{CAN\_UV}$  threshold, then the SPI bit **VCAN\_UV** is set and can be only cleared via SPI.

Note: The **VCC2\_UV** flag is not set during turn-on or turn-off of  $V_{CC2}$ .

## Supervision Functions

### 15.9 Thermal Protection

Three independent and different thermal protection features are implemented in the SBC according to the system impact:

- Individual thermal shutdown of specific blocks
- Temperature prewarning of main microcontroller supply VCC1
- SBC thermal shutdown due to VCC1 overtemperature

#### 15.9.1 Individual Thermal Shutdown

As a first-level protection measure the output stages VCC2, CAN, LINx, and HSx are independently switched OFF if the respective block reaches the temperature threshold  $T_{jTSD1}$ . Then the **TSD1** bit is set. This bit can only be cleared via SPI once the overtemperature is not present anymore. Independent of the SBC Mode the thermal shutdown protection is only active if the respective block is ON.

The respective modules behave as follows:

- VCC2: Is switched to OFF and the control bits **VCC2\_ON** are cleared. The status bit **VCC2\_OT** is set. Once the overtemperature condition is not present anymore, then VCC2 has to be configured again by SPI.
- VCC3 as a stand-alone regulator: Is switched to OFF and the control bits **VCC3\_ON** are cleared. The status bit **VCC3\_OT** is set. Once the overtemperature condition is not present anymore VCC3 has to be configured again by SPI. It is recommended to clear the **VCC3\_OT** bit before enabling the regulator again.
- VCC3 in load sharing configuration: in case of overtemperature at VCC3 the bit **VCC3\_OT** is set and VCC3 is switched off. The regulator will be switched on again automatically once the overtemperature event is not present anymore. Also in this case it is recommended to clear the **VCC3\_OT** bit right away.
- CAN: The transmitter is disabled and stays in CAN Normal Mode acting like CAN Receive only mode. The status bits **CAN\_FAIL** = '01' are set. Once the overtemperature condition is not present anymore, then the CAN transmitter is automatically switched on.
- LINx: The transmitter is disabled and stays in LIN Normal Mode acting like LIN Receive only mode. The status bits **LIN1\_FAIL** and **LIN2\_FAIL** respectively are set to '01'. Once the overtemperature condition is not present anymore, then the LIN transmitter is automatically switched on.
- HSx: If one or more HSx switches reach the TSD1 threshold, then all HSx switches are turned OFF and the control bits for HSx are cleared (see registers **HS\_CTRL1** and **HS\_CTRL2**). The status bits HSx\_OC\_OT are set (see register **HS\_OC\_OT\_STAT**). Once the overtemperature condition is not present anymore, then HSx has to be configured again by SPI.

*Note: The diagnosis bits are not cleared automatically and have to be cleared via SPI once the overtemperature condition is not present anymore.*

---

## Supervision Functions

### 15.9.2 Temperature Prewarning

As a next level of thermal protection a temperature prewarning is implemented if the main supply VCC1 reaches the thermal prewarning temperature threshold  $T_{jPW}$ . Then the status bit **TPW** is set. This bit can only be cleared via SPI once the overtemperature is not present anymore. Independent of the SBC Mode the thermal prewarning is only active if the VCC1 is ON.

### 15.9.3 SBC Thermal Shutdown

As a highest level of thermal protection a temperature shutdown of the SBC is implemented if the main supply VCC1 reaches the thermal shutdown temperature threshold  $T_{jTSD2}$ . Once a TSD2 event is detected SBC Fail-Safe Mode is entered for  $t_{TSD2}$  to allow the device to cool down. After this time has expired, the SBC will automatically change via SBC Restart Mode to SBC Normal Mode (see also [Chapter 5.1.6](#)).

When a TSD2 event is detected, then the status bit **TSD2** is set. This bit can only be cleared via SPI in SBC Normal Mode once the overtemperature is not present anymore. Independent of the SBC Mode the thermal shutdown is only active if VCC1 is ON.

## Supervision Functions

## 15.10 Electrical Characteristics

Table 28 Electrical Specification

$V_S = 5.5\text{ V to }28\text{ V}$ ;  $T_j = -40\text{ °C to }+150\text{ °C}$ ; SBC Normal Mode; all voltages with respect to ground; positive current defined flowing into pin; unless otherwise specified.

Parameter	Symbol	Values			Unit	Note or Test Condition	Number
		Min.	Typ.	Max.			
<b>VCC1 Monitoring; VCC1 = 3.3V Version</b>							
Undervoltage Prewarning Threshold Voltage PW,f 3.3V option	$V_{PW,f}$	3.0	3.1	3.2	V	VCC1 falling, SPI bit is set	P_15.10.36
Undervoltage Prewarning Threshold Voltage PW,r 3.3V option	$V_{PW,r}$	3.10	3.2	3.28	V	VCC1 rising	P_15.10.71
Reset Threshold Voltage RT1,f 3.3V option	$V_{RT1,f}$	2.95	3.05	3.15	V	default setting; VCC1 falling	P_15.10.37
Reset Threshold Voltage RT1,r 3.3V option	$V_{RT1,r}$	3.0	3.1	3.2	V	default setting; VCC1 rising	P_15.10.38
Reset Threshold Voltage RT2,f 3.3V option	$V_{RT2,f}$	2.5	2.6	2.7	V	VCC1 falling	P_15.10.39
Reset Threshold Voltage RT2,r 3.3V option	$V_{RT2,r}$	2.55	2.65	2.75	V	VCC1 rising	P_15.10.40
Reset Threshold Voltage RT3,f 3.3V option	$V_{RT3,f}$	2.2	2.3	2.4	V	SPI option; $V_S \geq 4\text{V}$ ; VCC1 falling	P_15.10.41
Reset Threshold Voltage RT3,r 3.3V option	$V_{RT3,r}$	2.25	2.35	2.45	V	$V_S \geq 4\text{V}$ ; VCC1 rising	P_15.10.42
Reset Threshold Voltage RT4,f 3.3V option	$V_{RT4,f}$	2.0	2.1	2.2	V	$V_S \geq 4\text{V}$ ; VCC1 falling	P_15.10.43
Reset Threshold Voltage RT4,r 3.3V option,	$V_{RT4,r}$	2.05	2.15	2.25	V	$V_S \geq 4\text{V}$ ; VCC1 rising,	P_15.10.44
Reset Threshold Hysteresis 3.3V option	$V_{RT,hys}$	30	67	140	mV	–	P_15.10.45
VCC1 Overvoltage Detection Threshold Voltage 3.3V option	$V_{CC1,OV,r}$	3.5	–	3.7	V	rising VCC1	P_15.10.70



## Supervision Functions

**Table 28 Electrical Specification** (cont'd)

$V_S = 5.5\text{ V to }28\text{ V}$ ;  $T_j = -40\text{ °C to }+150\text{ °C}$ ; SBC Normal Mode; all voltages with respect to ground; positive current defined flowing into pin; unless otherwise specified.

Parameter	Symbol	Values			Unit	Note or Test Condition	Number
		Min.	Typ.	Max.			
VCC1 Overvoltage Detection Threshold Voltage 3.3V option	$V_{CC1,OV,f}$	3.40	–	3.60	V	falling VCC1	P_15.10.73
VCC1 OV Detection Filter Time	$t_{VCC1,OV,F}$	5	10	14	us	2)	P_15.10.51
VCC1 Short to GND Filter Time	$t_{VCC1,SC}$	3.2	4	4.8	ms	2)	P_15.10.12

### Reset Generator; Pin RO

Reset Low Output Voltage	$V_{RO,L}$	–	0.2	0.4	V	$I_{RO} = 1\text{ mA}$ for $V_{CC1} \geq 1\text{ V}$ & $V_S \geq V_{POR,f}$	P_15.10.14
Reset High Output Voltage	$V_{RO,H}$	$0.8 \times V_{CC1}$	–	$V_{CC1} + 0.3\text{ V}$	V	$I_{RO} = -20\text{ }\mu\text{A}$	P_15.10.15
Reset Pull-up Resistor	$R_{RO}$	10	20	40	k $\Omega$	$V_{RO} = 0\text{ V}$	P_15.10.16
Reset Filter Time	$t_{RF}$	4	10	26	$\mu\text{s}$	2) $V_{CC1} < V_{RT1X}$ to RO = L see also <a href="#">Chapter 15.3</a>	P_15.10.17
Reset Delay Time	$t_{RD1}$	1.5	2	2.5	ms	1) 2)	P_15.10.18

### VCC2 Monitoring

VCC2 Undervoltage Threshold Voltage (falling)	$V_{CC2,UV,f}$	4.5	–	4.75	V	VCC2 falling	P_15.10.19
VCC2 Undervoltage Threshold Voltage (rising)	$V_{CC2,UV,r}$	4.6	–	4.9	V	VCC2 rising	P_15.10.77
VCC2 Undervoltage detection hysteresis	$V_{CC2,UV,hys}$	20	100	250	mV	–	P_15.10.20

### VCC3 Monitoring

VCC3 Undervoltage Detection	$V_{CC3,UV}$	2.65	2.85	3.00	V	3.3V option or <b>VCC3_V_CFG=0</b> hysteresis included	P_15.10.47
VCC3 Undervoltage Detection	$V_{CC3,UV}$	1.45	1.52	1.65	V	<b>VCC3_V_CFG=1</b> hysteresis included	P_15.10.61
VCC3 Undervoltage detection hysteresis	$V_{CC3,UV,hys}$	20	100	250	mV	–	P_15.10.22

## Supervision Functions

**Table 28 Electrical Specification** (cont'd)

$V_S = 5.5\text{ V to }28\text{ V}$ ;  $T_j = -40\text{ °C to }+150\text{ °C}$ ; SBC Normal Mode; all voltages with respect to ground; positive current defined flowing into pin; unless otherwise specified.

Parameter	Symbol	Values			Unit	Note or Test Condition	Number
		Min.	Typ.	Max.			
<b>VCAN Monitoring</b>							
CAN Supply undervoltage detection threshold	$V_{\text{CAN\_UV}}$	4.45	–	4.85	V	CAN Normal Mode, hysteresis included;	P_15.10.23
<b>Watchdog Generator</b>							
Long Open Window	$t_{\text{LW}}$	160	200	240	ms	2)	P_15.10.24
Internal Oscillator	$f_{\text{CLKSBC}}$	0.8	1.0	1.2	MHz	–	P_15.10.25
<b>Minimum Waiting time during SBC Fail-Safe Mode</b>							
Min. waiting time Fail-Safe	$t_{\text{FS,min}}$	80	100	120	ms	2)3)	P_15.10.75
<b>Power-on Reset, Over- / Undervoltage Protection</b>							
VS Power on reset rising	$V_{\text{POR,r}}$	–		4.5	V	VS increasing	P_15.10.26
VS Power on reset falling	$V_{\text{POR,f}}$	–		3	V	VS decreasing	P_15.10.27
VS Undervoltage Detection Threshold 3.3V option	$V_{\text{S,UV}}$	3.7	–	4.4	V	Supply UV threshold for VCC3 and VCC1 SC detection; hysteresis included	P_25.10.46
VSHS Overvoltage Detection Threshold	$V_{\text{SHS,OVD}}$	20		22	V	Supply OV supervision for HSx; hysteresis included	P_15.10.28
VSHS Overvoltage Detection hysteresis	$V_{\text{SHS,OVD,hys}}$	100	500	–	mV	4)	P_15.10.29
VSHS Undervoltage Detection Threshold	$V_{\text{SHS,UVD}}$	4.8		5.5	V	Supply UV supervision for LINx, HSx, and HS of GPIOx; hysteresis included	P_15.10.30
VSHS Undervoltage Detection hysteresis	$V_{\text{SHS,UVD,hys}}$	50	200	350	mV	4)	P_15.10.31
<b>Overtemperature Shutdown<sup>4)</sup></b>							
Thermal Prewarning Temperature	$T_{\text{jPW}}$	125	145	165	°C		P_15.10.32
Thermal Shutdown TSD1	$T_{\text{jTSD1}}$	165	185	200	°C		P_15.10.33

## Supervision Functions

**Table 28 Electrical Specification** (cont'd)

$V_S = 5.5\text{ V to }28\text{ V}$ ;  $T_j = -40\text{ °C to }+150\text{ °C}$ ; SBC Normal Mode; all voltages with respect to ground; positive current defined flowing into pin; unless otherwise specified.

Parameter	Symbol	Values			Unit	Note or Test Condition	Number
		Min.	Typ.	Max.			
Thermal Shutdown TSD2	$T_{jTSD2}$	165	185	200	°C		P_15.10.34
Thermal Shutdown hysteresis	$T_{jTSD,hys}$	5	15	25	°C		P_15.10.68
Deactivation time after thermal shutdown TSD2	$t_{TSD2}$	0.8	1	1.2	s	<sup>2)</sup>	P_15.10.35

- 1) The reset delay time will start when VCC1 crosses above the selected Vrtx threshold
- 2) Not subject to production test, tolerance defined by internal oscillator tolerance.
- 3) This time applies for all failure entries except a device thermal shutdown (TSD2 has a typ. 1s waiting time  $t_{TSD2}$ )
- 4) Not subject to production test, specified by design.

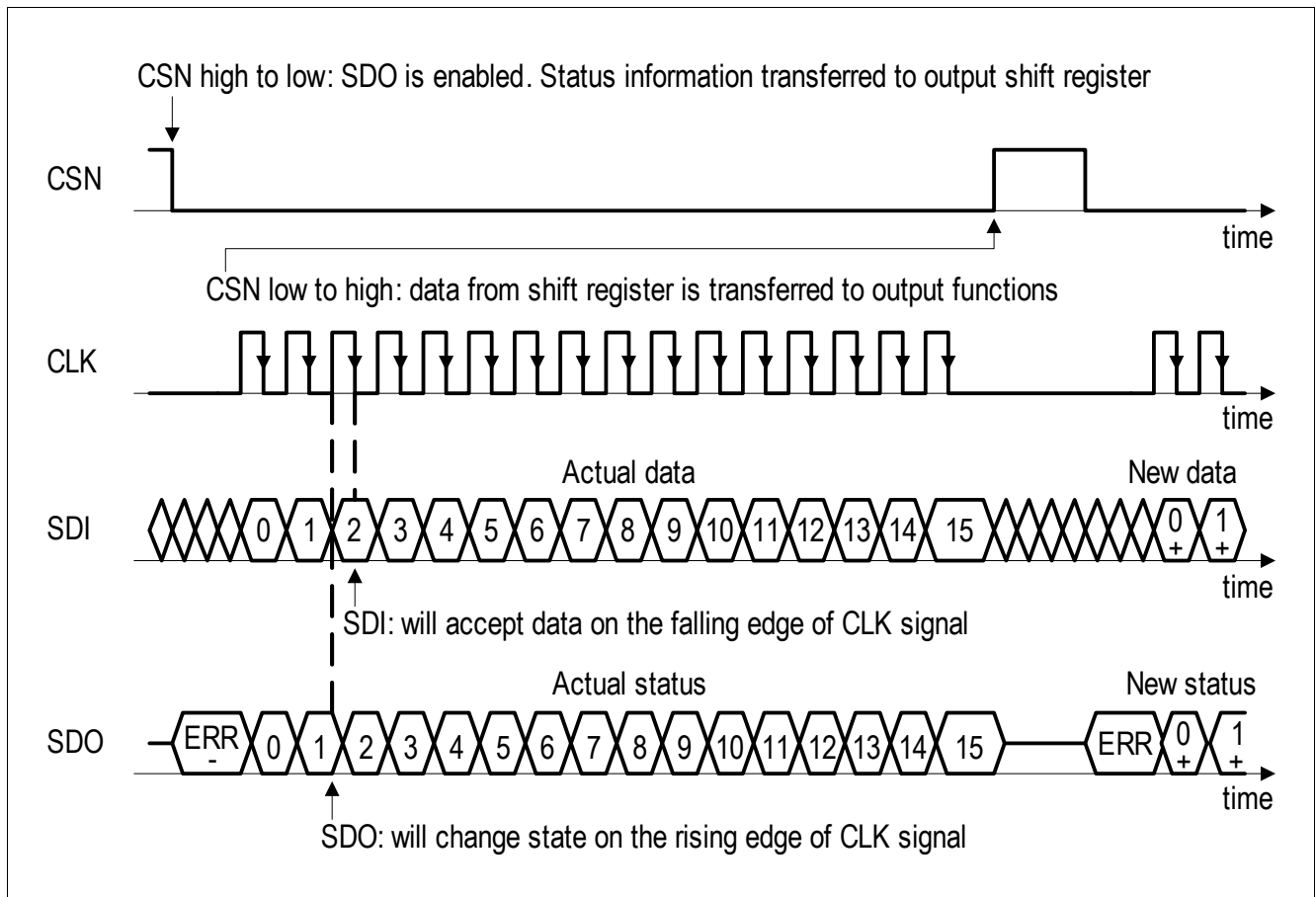
Serial Peripheral Interface

## 16 Serial Peripheral Interface

### 16.1 SPI Block Description

The 16-bit wide Control Input Word is read via the data input SDI, which is synchronized with the clock input CLK provided by the microcontroller. The output word appears synchronously at the data output SDO (see [Figure 54](#)).

The transmission cycle begins when the chip is selected by the input CSN (Chip Select Not), LOW active. After the CSN input returns from LOW to HIGH, the word that has been read is interpreted according to the content. The SDO output switches to tristate status (high impedance) at this point, thereby releasing the SDO bus for other use. The state of SDI is shifted into the input register with every falling edge on CLK. The state of SDO is shifted out of the output register after every rising edge on CLK. The SPI of the SBC is not daisy chain capable.



**Figure 54 SPI Data Transfer Timing (note the reversed order of LSB and MSB shown in this figure compared to the register description)**

## Serial Peripheral Interface

### 16.2 Failure Signalization in the SPI Data Output

When the microcontroller sends a wrong SPI command to the SBC, the SBC ignores the information. Wrong SPI commands are either invalid SBC mode commands or commands which are prohibited by the state machine to avoid undesired device or system states (see below). In this case the diagnosis bit '**SPI\_FAIL**' is set and the SPI Write command is ignored (mostly no partial interpretation). This bit can be only reset by actively clearing it via a SPI command.

#### Invalid SPI Commands leading to **SPI\_FAIL** are listed below:

- Illegal state transitions: Going from SBC Stop to SBC Sleep Mode. In this case the SBC enters in addition the SBC Restart Mode;  
Trying to go to SBC Stop or SBC Sleep mode from SBC Init Mode. In this case SBC Normal Mode is entered;
- Uneven parity in the data bit of the **WD\_CTRL** register. In this case the watchdog trigger is ignored or the new watchdog settings are ignored respectively;
- In SBC Stop Mode: attempting to change any SPI settings, e.g. changing the watchdog configuration, PWM settings and HS configuration settings during SBC Stop Mode, etc.;  
the SPI command is ignored in this case;  
only WD trigger, returning to Normal Mode, triggering a SBC Soft Reset, and Read & Clear status registers commands are valid SPI commands in SBC Stop Mode;
- When entering SBC Stop Mode and **WK\_STAT\_1** and **WK\_STAT\_2** are not cleared; **SPI\_FAIL** will not be set but the INT pin will be triggered;
- Changing from SBC Stop to Normal Mode and changing the other bits of the **M\_S\_CTRL** register. The other modifications will be ignored;
- SBC Sleep Mode: attempt to go to Sleep Mode when all bits in the **BUS\_CTRL\_1**, **BUS\_CTRL\_2** and **WK\_CTRL\_2** registers are cleared. In this case the **SPI\_FAIL** bit is set and the SBC enters Restart Mode.  
Even though the Sleep Mode command is not entered in this case, the rest of the command (e.g. modifying VCC2 or VCC3) is executed and the values stay unchanged during SBC Restart Mode;  
Note: At least one wake source must be activated in order to avoid a deadlock situation in SBC Sleep Mode, i.e. the SBC would not be able to wake up anymore.  
If the only wake source is a timer and the timer is OFF then the SBC will wake immediately from Sleep Mode and enter Restart Mode;  
No failure handling is done for the attempt to go to SBC STOP Mode when all bits in the registers **BUS\_CTRL\_1**, **BUS\_CTRL\_2** and **WK\_CTRL\_2** are cleared because the microcontroller can leave this mode via SPI;
- If VCC3 load sharing **VCC3\_LS** is enabled and the microcontroller tries to clear the bit, then the rest of the command executed but **VCC3\_LS** will remain set;
- Attempt to enter SBC Sleep Mode if WK\_MEAS is set to '1' and only WK1\_EN or WK2\_EN are set as wake sources. Also in this case the **SPI\_FAIL** bit is set and the SBC enters Restart Mode;
- Setting a longer or equal on-time than the timer period of the respective timer;
- SDI stuck at HIGH or LOW, e.g. SDI received all '0' or all '1';

Note: *There is no SPI fail information for unused addresses.*

#### Signalization of the ERR Flag (high active) in the SPI Data Output (see [Figure 54](#)):

The ERR flag presents an additional diagnosis possibility for the SPI communication. The ERR flag is being set for following conditions:

- in case the number of received SPI clocks is not 0 or 16,
- in case RO is LOW and SPI frames are being sent at the same time.

---

## Serial Peripheral Interface

*Note: In order to read the SPI ERR flag properly, CLK must be low when CSN is triggered, i.e. the ERR bit is not valid if the CLK is high on a falling edge of CSN*

### **The number of received SPI clocks is not 0 or 16:**

The number of received input clocks is supervised to be 0- or 16 clock cycles and the input word is discarded in case of a mismatch (0 clock cycle to enable ERR signalization). The error logic also recognizes if CLK was high during CSN edges. Both errors - 0 bit and 16 bit CLK mismatch or CLK high during CSN edges - are flagged in the following SPI output by a "HIGH" at the data output (SDO pin, bit ERR) before the first rising edge of the clock is received. The complete SPI command is ignored in this case.

### **RO is LOW and SPI frames are being sent at the same time:**

The ERR flag will be set when the RO pin is triggered (during SBC Restart) and SPI frames are being sent to the SBC at the same time. The behavior of the ERR flag will be signaled at the next SPI command for below conditions:

- if the command begins when RO is HIGH and it ends when RO is LOW,
- if a SPI command will be sent while RO is LOW,
- If a SPI command begins when RO is LOW and it ends when RO is HIGH.

and the SDO output will behave as follows:

- always when RO is LOW then SDO will be HIGH,
- when a SPI command begins with RO is LOW and ends when RO is HIGH, then the SDO should be ignored because wrong data will be sent.

*Note: It is possible to quickly check for the ERR flag without sending any data bits. i.e. only the CSN is pulled low and SDO is observed - no SPI Clocks are sent in this case*

*Note: The ERR flag could also be set after the SBC has entered SBC Fail-Safe Mode because the SPI communication is stopped immediately.*

## Serial Peripheral Interface

### 16.3 SPI Programming

For the TLE9263BQXV33, 7 bits are used for the address selection (BIT6...0). Bit 7 is used to decide between Read Only and Read & Clear for the status bits, and between Write and Read Only for configuration bits. For the actual configuration and status information, 8 data bits (BIT15...8) are used.

Writing, clearing and reading is done byte wise. The SPI status bits are not cleared automatically and must be cleared by the microcontroller, e.g. if the TSD2 was set due to overtemperature. The configuration bits will be partially automatically cleared by the SBC - please refer to the individual registers description for detailed information. During SBC Restart Mode the SPI communication is ignored by the SBC, i.e. it is not interpreted.

There are two types of SPI registers:

- Control registers: Those are the registers to configure the SBC, e.g. SBC mode, watchdog trigger, etc
- Status registers: Those are the registers where the status of the SBC is signalled, e.g. wake events, warnings, failures, etc.

For the status registers, the requested information is given in the same SPI command in DO.

For the control registers, also the status of the respective byte is shown in the same SPI command. However, if the setting is changed this is only shown with the next SPI command (it is only valid after CSN high) of the same register.

The SBC status information from the SPI status registers, is transmitted in a compressed way with each SPI response on SDO in the so called Status Information Field register (see also [Figure 55](#)). The purpose of this register is to quickly signal the information to the microcontroller if there was a change in one of the SPI status registers. In this way, the microcontroller does not need to read constantly all the SPI status registers but only those registers, which were changed.

Each bit in the Status Information Field represents a SPI status register (see [Table 29](#)). As soon as one bit is set in one of the status registers, then the respective bit in the Status Information Field register will be set. The register **WK\_LVL\_STAT** is not included in the status Information field. This is listed in [Table 29](#).

For Example if bit 0 in the Status Information Field is set to 1, one or more bits of the register 100 0001 (**SUP\_STAT\_1**) is set to 1. Then this register needs to be read in a second SPI command. The bit in the Status Information Field will be set to 0 when all bits in the register 100 0001 are set back to 0.

**Table 29 Status Information Field**

Bit in Status Information Field	Corresponding Address Bit	Status Register Description
0	100 0001	SUP_STAT_1: Supply Status -VSHS fail, VCCx fail, POR
1	100 0010	THERM_STAT: Thermal Protection Status
2	100 0011	DEV_STAT: Device Status - Mode before Wake, WD Fail, SPI Fail, Failure
3	100 0100	BUS_STAT: Bus Failure Status: CAN, LINx; BUS_STAT_1 & BUS_STAT_2 are a combinational OR
4	100 0110	WK_STAT_1, WK_STAT_2: Wake Source Status; Status bit is set as combinational OR of both registers
5	100 0000	SUP_STAT_2: VCC1_WARN/OV, VCC3 Status
6	101 0100	HS_OC_OT_STAT: High-Side Over Load Status
7	101 0101	HS_OL_STAT: High-Side Open Load Status

Serial Peripheral Interface

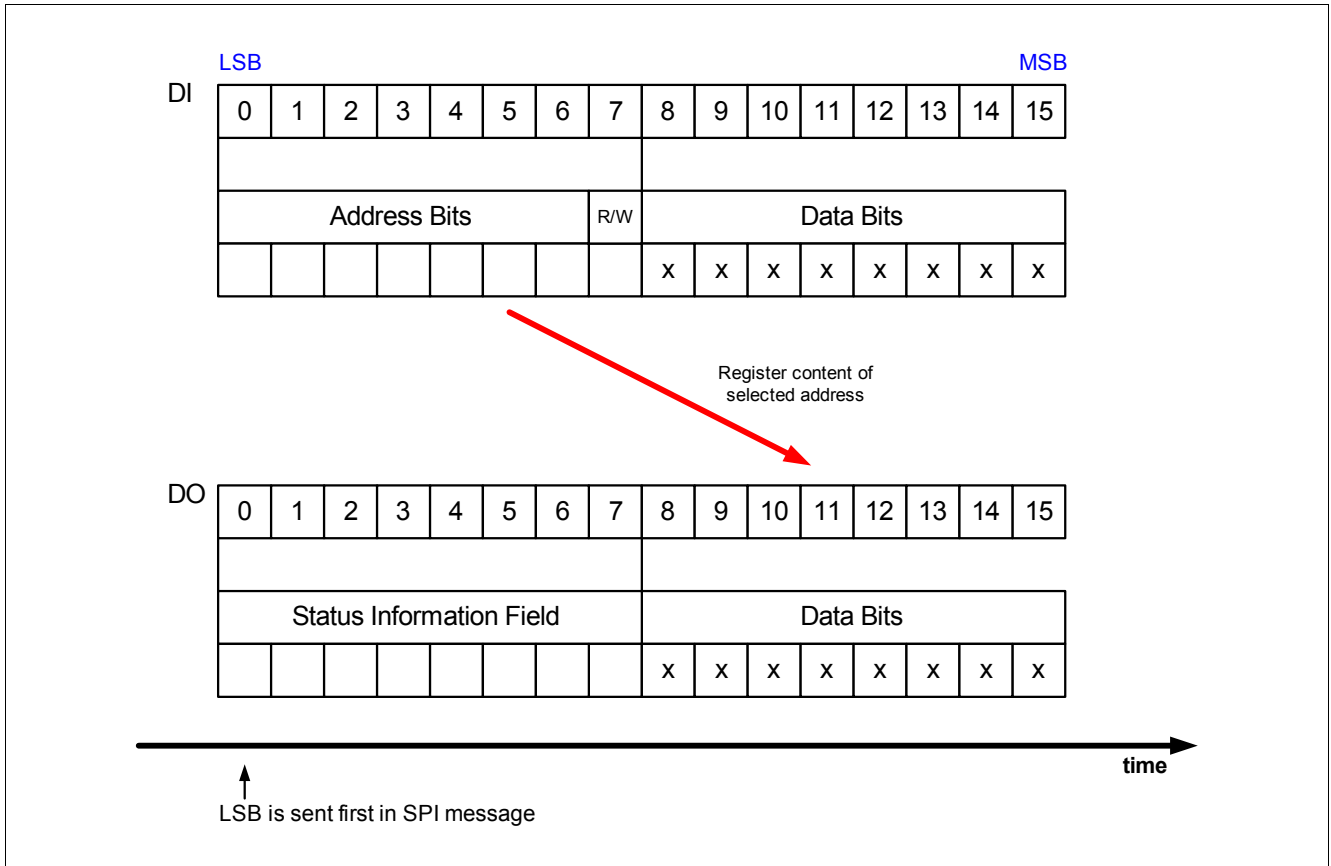


Figure 55 SPI Operation Mode



## Serial Peripheral Interface

### 16.4 SPI Bit Mapping

The following figures show the mapping of the registers and the SPI bits of the respective registers.

The Control Registers '000 0000' to '001 1110' are Read/Write Register. Depending on bit 7 the bits are only read (setting bit 7 to '0') or also written (setting bit 7 to '1'). The new setting of the bit after write can be seen with a new read / write command.

The registers '100 0000' to '111 1110' are Status Registers and can be read or read with clearing the bit (if possible) depending on bit 7. To clear a Data Byte of one of the Status Registers bit 7 must be set to 1. The registers **WK\_LVL\_STAT**, and **FAM\_PROD\_STAT** are an exception as they show the actual voltage level at the respective WK pin (LOW/HIGH), or a fixed family/ product ID respectively and can thus not be cleared. It is recommended for proper diagnosis to clear respective status bits for wake events or failure. However, in general it is possible to enable drivers without clearing the respective failure flags.

When changing to a different SBC Mode, certain configurations bits will be cleared automatically or modified:

- The SBC Mode bits are updated to the actual status, e.g. when returning to Normal Mode
- When changing to a low-power mode (Stop/Sleep), the diagnosis bits of the switches and transceivers are not cleared. FOx will stay activated if it was triggered before.
- When changing to SBC Stop Mode, the CAN and LIN control bits will not be modified.
- When changing to SBC Sleep Mode, the CAN and LIN control bits will be modified if they were not OFF or wake capable before.
- HSx, VCC2 and VCC3 will stay on when going to Sleep-/Stop Mode (configuration can only be done in Normal Mode). Diagnosis is active (OC, OL, OT). In case of a failure the switch is turned off and no wake-up is issued
- The configuration bits for HSx and VCC2 in stand-alone configuration are cleared in SBC Restart Mode. FOx will stay activated if it was triggered before. Depending on the respective configuration, CAN/LIN transceivers will be either OFF, woken or still wake capable.

*Note:* The detailed behavior of the respective SPI bits and control functions is described in **Chapter 16.5**, **Chapter 16.6** and in the respective module chapter. The bit type be marked as 'rwh' in case the SBC will modify respective control bits.

Serial Peripheral Interface

MSB								LSB										
15	14	13	12	11	10	9	8	7	6	5	4	3	2	1	0			
8 Data Bits [bits 8...15] for Configuration & Status Information								Reg. Type	7 Address Bits [bits 0...6] for Register Selection									
<b>Control Registers</b>								M_S_CTRL	rw	0	0	0	0	0	0	1		
								HW_CTRL	rw	0	0	0	0	0	1	0		
								WD_CTRL	rw	0	0	0	0	0	1	1		
								BUS_CTRL_1	rw	0	0	0	0	1	0	0		
								BUS_CTRL_2	rw	0	0	0	0	1	0	1		
								WK_CTRL_1	rw	0	0	0	0	1	1	0		
								WK_CTRL_2	rw	0	0	0	0	1	1	1		
								WK_PUPD_CTRL	rw	0	0	0	1	0	0	0		
								WK_FLT_CTRL	rw	0	0	0	1	0	0	1		
								TIMER1_CTRL	rw	0	0	0	1	1	0	0		
								TIMER2_CTRL	rw	0	0	0	1	1	0	1		
								SW_SD_CTRL	rw	0	0	1	0	0	0	0		
								HS_CTRL_1	rw	0	0	1	0	1	0	0		
								HS_CTRL_2	rw	0	0	1	0	1	0	1		
								GPIO_CTRL	rw	0	0	1	0	1	1	1		
								PWM1_CTRL	rw	0	0	1	1	0	0	0		
								PWM2_CTRL	rw	0	0	1	1	0	0	1		
								PWM_FREQ_CTRL	rw	0	0	1	1	1	0	0		
								SYS_STAT_CTRL	rw	0	0	1	1	1	1	0		
								<b>Status Registers</b>								SUP_STAT_2	rc	1
SUP_STAT_1	rc	1	0	0	0	0	0									1	0	
THERM_STAT	rc	1	0	0	0	0	1									0	1	
DEV_STAT	rc	1	0	0	0	0	1									1	2	
BUS_STAT_1	rc	1	0	0	0	1	0									0	3	
BUS_STAT_2	rc	1	0	0	0	1	0									1	3	
WK_STAT_1	rc	1	0	0	0	1	1									0	4	
WK_STAT_2	rc	1	0	0	0	1	1									1	4	
WK_LVL_STAT	r	1	0	0	1	0	0									0	-	
HS_OC_OT_STAT	rc	1	0	1	0	1	0									0	6	
HS_OL_STAT	rc	1	0	1	0	1	0	1	7									
FAM_PROD_STAT	r	1	1	1	1	1	1	0										

Figure 56 SPI Register Mapping

Serial Peripheral Interface

Register Short Name	15	14	13	12	11	10	9	8	7	6...0
	D7	D6	D5	Data Bit 15...8 D4	D3	D2	D1	D0	Access Mode	Address Ab...A0
<b>CONTROL REGISTERS</b>										
M_S_CTRL	MODE_1	MODE_0	VCC3_ON	VCC2_ON_1	VCC2_ON_0	VCC1_OV_RST	VCC1_RT_1	VCC1_RT_0	read/write	0000001
HW_CTRL	VCC3_V_CFG	SOFT_RESET_RO	FO_ON	VCC3_US_OV_OFF	VCC3_LS	reserved	VCC3_LS_STP_ON	CFG	read/write	0000010
WD_CTRL	CHECKSUM	WD_STM_EN_0	WD_WIN	WD_EN_WK_BUS	reserved	WD_TIMER_2	WD_TIMER_1	WD_TIMER_0	read/write	0000011
BUS_CTRL_1	LIN_FLASH	LIN_LSM	LIN_TXD_TO	LIN_1	LIN_0	reserved	CAN_1	CAN_0	read/write	0000100
BUS_CTRL_2	reserved	reserved	I_PEAK_TH	reserved	reserved	reserved	LIN2_1	LIN2_0	read/write	0000101
WK_CTRL_1	TIMER2_WK_EN	TIMER1_WK_EN	reserved	reserved	reserved	WD_STM_EN_1	reserved	reserved	read/write	0000110
WK_CTRL_2	INT_GLOBAL	reserved	WK_MEAS	reserved	reserved	WK_EN	WK2_EN	WK1_EN	read/write	0000111
WK_PUPD_CTRL	reserved	reserved	WK3_PUPD_1	reserved	reserved	WK2_PUPD_0	WK1_PUPD_1	WK1_PUPD_0	read/write	0001000
WK_FLT_CTRL	reserved	reserved	WK3_FLT_1	reserved	reserved	WK2_FLT_0	WK1_FLT_1	WK1_FLT_0	read/write	0001001
TIMER1_CTRL	reserved	reserved	TIMER1_ON_1	reserved	reserved	TIMER1_PER_2	TIMER1_PER_1	TIMER1_PER_0	read/write	0001100
TIMER2_CTRL	reserved	reserved	TIMER2_ON_1	reserved	reserved	TIMER2_PER_2	TIMER2_PER_1	TIMER2_PER_0	read/write	0001101
SW_SD_CTRL	reserved	reserved	HS_OV_SD_EN	reserved	reserved	reserved	reserved	reserved	read/write	0010000
HS_CTRL_1	reserved	HS2_2	HS2_1	HS2_0	reserved	HS1_2	HS1_1	HS1_0	read/write	0010100
HS_CTRL_2	reserved	HS4_2	HS4_1	HS4_0	reserved	HS3_2	HS3_1	HS3_0	read/write	0010101
GPIO_CTRL	FO_DC_1	FO_DC_0	GPIO2_2	GPIO2_1	GPIO2_0	GPIO1_2	GPIO1_1	GPIO1_0	read/write	0010111
PWM1_CTRL	PWM1_DC_7	PWM1_DC_6	PWM1_DC_5	PWM1_DC_4	PWM1_DC_3	PWM1_DC_2	PWM1_DC_1	PWM1_DC_0	read/write	0011000
PWM2_CTRL	PWM2_DC_7	PWM2_DC_6	PWM2_DC_5	PWM2_DC_4	PWM2_DC_3	PWM2_DC_2	PWM2_DC_1	PWM2_DC_0	read/write	0011001
PWM_FREQ_CTRL	reserved	reserved	reserved	reserved	reserved	PWM2_FREQ_0	reserved	reserved	read/write	0011100
SYS_STAT_CTRL	SYS_STAT_7	SYS_STAT_6	SYS_STAT_5	SYS_STAT_4	SYS_STAT_3	SYS_STAT_2	SYS_STAT_1	SYS_STAT_0	read/write	0011110
<b>STATUS REGISTERS</b>										
SUP_STAT_2	reserved	V_S_UV	reserved	VCC3_OC	VCC3_UV	VCC3_OT	VCC1_OV	VCC1_WARN	read/clear	1000000
SUP_STAT_1	POR	VSHS_UV	VSHS_OV	VCC2_OT	VCC2_UV	VCC1_SC	VCC1_UV_FS	VCC1_UV	read/clear	1000001
THERM_STAT	reserved	reserved	reserved	reserved	reserved	TSD1	TPW	reserved	read/clear	1000010
DEV_STAT	DEV_STAT_1	DEV_STAT_0	reserved	reserved	WD_FAIL_1	WD_FAIL_0	SPI_FAIL	FAILURE	read/clear	1000011
BUS_STAT_1	reserved	reserved	LIN1_FAIL_1	reserved	reserved	CAN_FAIL_1	CAN_FAIL_0	VCAN_UV	read/clear	1000100
BUS_STAT_2	reserved	reserved	LIN1_WU	reserved	reserved	LIN2_FAIL_1	LIN2_FAIL_0	reserved	read/clear	1000101
WK_STAT_1	reserved	reserved	CAN_WU	reserved	reserved	WK3_WU	WK2_WU	WK1_WU	read/clear	1000110
WK_STAT_2	reserved	reserved	GPIO2_WU	GPIO1_WU	reserved	reserved	reserved	reserved	read/clear	1000111
WK_LVL_STAT	SBC_DEV_LVL	CFGP	GPIO2_LVL	GPIO1_LVL	reserved	WK3_LVL	WK2_LVL	WK1_LVL	read	1001000
HS_OC_OT_STAT	reserved	reserved	reserved	HS4_OC_OT	HS3_OC_OT	HS2_OC_OT	HS2_OC_OT	HS1_OC_OT	read/clear	1010100
HS_OL_STAT	reserved	reserved	reserved	HS4_OL	HS3_OL	HS2_OL	HS2_OL	HS1_OL	read/clear	1010101
<b>FAMILY AND PRODUCT REGISTERS</b>										
FAM_PROD_STAT	FAM_3	FAM_2	FAM_1	FAM_0	PROD_3	PROD_2	PROD_1	PROD_0	read	1111110

Figure 57 TLE9263BQXV33 SPI Bit Mapping

---

## Serial Peripheral Interface

### 16.5 SPI Control Registers

READ/WRITE Operation (see also [Chapter 16.3](#)):

- The 'POR / Soft Reset Value' defines the register content after POR or SBC Reset.
- The 'Restart Value' defines the register content after SBC Restart, where 'x' means the bit is unchanged.
- One 16-bit SPI command consist of two bytes:
  - the 7-bit address and one additional bit for the register access mode and
  - following the data byteThe numbering of following bit definitions refers to the data byte and correspond to the bits D0...D7 and to the SPI bits 8...15 (see also figure before).
- There are three different bit types:
  - 'r' = READ: read only bits (or reserved bits)
  - 'rw' = READ/WRITE: readable and writable bits
  - 'rwh' = READ/WRITE/Hardware: readable/writable bits, which can also be modified by the SBC hardware
- Reserved bits are marked as "Reserved" and always read as "0". The respective bits shall also be programmed as "0".
- Reading a register is done byte wise by setting the SPI bit 7 to "0" (= Read Only).
- Writing to a register is done byte wise by setting the SPI bit 7 to "1".
- SPI control bits are in general not cleared or changed automatically. This must be done by the microcontroller via SPI programming. Exceptions to this behavior are stated at the respective register description and the respective bit type is marked with a 'h' meaning that the SBC is able to change the register content.

The registers are addressed wordwise.

## Serial Peripheral Interface

## 16.5.1 General Control Registers

## M\_S\_CTRL

Mode- and Supply Control (Address 000 0001<sub>B</sub>)POR / Soft Reset Value: 0000 0000<sub>B</sub>; Restart Value: 00x0 00xx<sub>B</sub>

7	6	5	4	3	2	1	0
MODE_1	MODE_0	VCC3_ON	VCC2_ON_1	VCC2_ON_0	VCC1_OV_RST	VCC1_RT_1	VCC1_RT_0
rwh	rwh	rwh	rwh	rwh	rwh	rw	rw

Field	Bits	Type	Description
MODE	7:6	rwh	<b>SBC Mode Control</b> 00B , SBC Normal Mode 01B , SBC Sleep Mode 10B , SBC Stop Mode 11B , SBC Reset: Soft Reset is executed (configuration of RO triggering in bit <a href="#">SOFT_RESET_RO</a> )
VCC3_ON	5	rwh	<b>VCC3 Mode Control</b> 0B , VCC3 OFF 1B , VCC3 is enabled (as independent voltage regulator)
VCC2_ON	4:3	rwh	<b>VCC2 Mode Control</b> 00B , VCC2 off 01B , VCC2 on in Normal Mode 10B , VCC2 on in Normal and Stop Mode 11B , VCC2 always on (except in SBC Fail-Safe Mode)
VCC1_OV_RST	2	rwh	<b>VCC1 Overvoltage leading to Restart / Fail-Safe Mode enable</b> 0B , <a href="#">VCC1_OV</a> is set in case of VCC1_OV; no SBC Restart or Fail-Safe is entered for VCC1_OV 1B , <a href="#">VCC1_OV</a> is set in case of VCC1_OV; depending on the device configuration SBC Restart or SBC Fail-Safe Mode is entered (see <a href="#">Chapter 5.1.1</a> );
VCC1_RT	1:0	rw	<b>VCC1 Reset Threshold Control</b> 00B , Vrt1 selected (highest threshold) 01B , Vrt2 selected 10B , Vrt3 selected 11B , Vrt4 selected

## Notes

1. It is not possible to change from Stop to Sleep Mode via SPI Command. See also the State Machine Chapter
2. After entering SBC Restart Mode, the MODE bits will be automatically set to SBC Normal Mode. The VCC2\_ON bits will be automatically set to OFF after entering SBC Restart Mode and after OT.
3. The SPI output will always show the previously written state with a Write Command (what has been programmed before)

## Serial Peripheral Interface

## HW\_CTRL

Mode- and Supply Control (Address 000 0010<sub>B</sub>)POR / Soft Reset Value: y000 y000<sub>B</sub>; Restart Value: xx0x x00x<sub>B</sub>

7	6	5	4	3	2	1	0
VCC3_V_CFG	SOFT_RESET_RO	FO_ON	VCC3_VS_UV_OFF	VCC3_LS	Reserved	VCC3_LS_STP_ON	CFG
rw	rw	rwh	rw	rw	r	rw	rw

Field	Bits	Type	Description
VCC3_V_CFG	7	rw	<b>VCC3 Output Voltage Configuration (if configured as independent voltage regulator)</b> 0B , VCC3 has same output voltage as VCC1 1B , VCC3 is configured to either 3.3V or 1.8V (depending on VCC1 derivative)
SOFT_RESET_RO	6	rw	<b>Soft Reset Configuration</b> 0B , RO will be triggered (pulled low) during a Soft Reset 1B , No RO triggering during a Soft Reset
FO_ON	5	rwh	<b>Failure Output Activation (FO1..3)</b> 0B , FOx not activated by software, FO can be activated by defined failures (see <a href="#">Chapter 14</a> ) 1B , FOx activated by software (via SPI)
VCC3_VS_UV_OFF	4	rw	<b>VCC3 VS_UV shutdown configuration</b> 0B , VCC3 will be disabled automatically at VS_UV 1B , VCC3 will stay enabled even below VS_UV
VCC3_LS	3	rw	<b>VCC3 Configuration</b> 0B , VCC3 operating as a stand-alone regulator 1B , VCC3 in load sharing operation with VCC1
Reserved	2	r	<b>Reserved, always reads as 0</b>
VCC3_LS_STP_ON	1	rw	<b>VCC3 Load Sharing in SBC Stop Mode configuration</b> 0B , VCC3 in LS configuration during SBC Stop Mode and high-power mode: disabled 1B , VCC3 in LS configuration during SBC Stop Mode and high-power mode: enabled
CFG	0	rw	<b>Configuration Select (see also <a href="#">Table 5</a>)</b> 0B , Depending on hardware configuration, SBC Restart or Fail-Safe Mode is reached after the 2. watchdog trigger failure (=default) - Config 3/4 1B , Depending on hardware configuration, SBC Restart or Fail-Safe Mode is reached after the 1. watchdog trigger failure - Config 1/2

## Notes

1. Clearing the FO\_ON bit will not disable the FOx outputs for the case a failure occurred which triggered the FOx outputs. In this case the FOx outputs have to be disabled by clearing the FAILURE bit.

---

## Serial Peripheral Interface

*If the FO\_ON bit is set by the software then it will be cleared by the SBC after SBC Restart Mode was entered and the FOx outputs will be disabled. See also [Chapter 14](#) for FOx activation and deactivation.*

- 2. After triggering a SBC Soft Reset the bits VCC3\_V\_CFG and VCC3\_LS are not reset if they were set before, i.e. it stays unchanged, which is stated by the 'y' in the POR / Soft Reset Value. POR value: 0000 0000 and Soft Reset value: xx00 x00x*
- 3. VCC3\_LS\_STP\_ON: Is a combination of load sharing and VCC1 active peak in Stop mode*

## Serial Peripheral Interface

## WD\_CTRL

Watchdog Control (Address 000 0011<sub>B</sub>)POR / Soft Reset Value: 0001 0100<sub>B</sub>; Restart Value: x0xx 0100<sub>B</sub>

7	6	5	4	3	2	1	0
CHECKSUM	WD_STM_ EN_0	WD_WIN	WD_EN_ WK_BUS	Reserved	WD_TIMER_2	WD_TIMER_1	WD_TIMER_0
rw	rwh	rw	rw	r	rwh	rwh	rwh

Field	Bits	Type	Description
CHECKSUM	7	rw	<b>Watchdog Setting Check Sum Bit</b> The sum of bits 7:0 needs to have even parity (see <a href="#">Chapter 15.2.3</a> ) 0B , Counts as 0 for checksum calculation 1B , Counts as 1 for checksum calculation
WD_STM_EN_0	6	rwh	<b>Watchdog Deactivation during Stop Mode, bit 0</b> ( <a href="#">Chapter 15.2.4</a> ) 0B , Watchdog is active in Stop Mode 1B , Watchdog is deactivated in Stop Mode
WD_WIN	5	rw	<b>Watchdog Type Selection</b> 0B , Watchdog works as a Time-Out watchdog 1B , Watchdog works as a Window watchdog
WD_EN_WK_BUS	4	rw	<b>Watchdog Enable after Bus (CAN/LIN) Wake in SBC Stop Mode</b> 0B , Watchdog will not start after a CAN/LINx wake 1B , Watchdog starts with a long open window after CAN/LINx Wake
Reserved	3	r	<b>Reserved, always reads as 0</b>
WD_TIMER	2:0	rwh	<b>Watchdog Timer Period</b> 000B , 10ms 001B , 20ms 010B , 50ms 011B , 100ms 100B , 200ms 101B , 500ms 110B , 1000ms 111B , reserved

## Notes

1. See also [Chapter 15.2.4](#) for more information on disabling the watchdog in SBC Stop Mode.
2. See [Chapter 15.2.5](#) for more information on the effect of the bit WD\_EN\_WK\_BUS.
3. See [Chapter 15.2.3](#) for calculation of checksum.



## Serial Peripheral Interface

**BUS\_CTRL\_1****Bus Control (Address 000 0100<sub>B</sub>)****POR / Soft Reset Value: 0010 0000<sub>B</sub>;****Restart Value: xxxy y0yy<sub>B</sub>**

7	6	5	4	3	2	1	0
<b>LIN_FLASH</b>	<b>LIN_LSM</b>	<b>LIN_TXD_TO</b>	<b>LIN1_1</b>	<b>LIN1_0</b>	<b>Reserved</b>	<b>CAN_1</b>	<b>CAN_0</b>
rw	rw	rw	rwh	rwh	r	rwh	rwh

Field	Bits	Type	Description
<b>LIN_FLASH</b>	7	rw	<b>LINx Flash Programming Mode</b> 0B , Slope control mechanism active 1B , Deactivation of slope control for baud rates up to 115kBaud
<b>LIN_LSM</b>	6	rw	<b>LINx Low-Slope Mode Selection</b> 0B , LIN Normal-Mode is activated 1B , LIN Low-Slope Mode (10.4kBaud) activated
<b>LIN_TXD_TO</b>	5	rw	<b>LINx TXD Time-Out Control</b> 0B , TXD Time-Out feature disabled 1B , TXD Time-Out feature enabled
<b>LIN1</b>	4:3	rwh	<b>LIN1-Module Mode</b> 00B , LIN1 OFF 01B , LIN1 is wake capable 10B , LIN1 Receive Only Mode 11B , LIN1 Normal Mode
<b>Reserved</b>	2	r	<b>Reserved, always reads as 0</b>
<b>CAN</b>	1:0	rwh	<b>HS-CAN Module Modes</b> 00B , CAN OFF 01B , CAN is wake capable 10B , CAN Receive Only Mode 11B , CAN Normal Mode

**Notes**

- Changes in the bits **LIN\_FLASH**, **LIN\_LSM**, and **LIN\_TXD\_TO** will be effective immediately once CSN goes to '1' and applies for both LIN transceivers.'
- The reset values for the LINx and CAN transceivers are marked with 'y' because they will vary depending on the cause of change - see below.
- see [Figure 26](#) and [Figure 33](#) for detailed state changes of LIN and CAN Transceiver for different SBC modes.
- Failure Handling Mechanism: When the device enters Fail-Safe Mode due to a failure (TSD2, WD-Failure,...), then the wake registers **BUS\_CTRL\_1**, **BUS\_CTRL\_2** and **WK\_CTRL\_2** are reset to following values (=wake sources) 'xxx0 1001', '0000 0001' and 'x0x0 0111' in order to ensure that the device can be woken again.

## Serial Peripheral Interface

**BUS\_CTRL\_2****Bus Control (Address 000 0101<sub>B</sub>)****POR / Soft Reset Value: 0000 0000<sub>B</sub>; Restart Value: 00x0 00yy<sub>B</sub>**

7	6	5	4	3	2	1	0
Reserved	Reserved	I_PEAK_TH	Reserved	Reserved	Reserved	LIN2_1	LIN2_0
r	r	rw	r	r	r	rwh	rwh

Field	Bits	Type	Description
Reserved	7:6	r	Reserved, always reads as 0
I_PEAK_TH	5	rw	<b>VCC1 Active Peak Threshold Selection</b> 0B , low VCC1 active peak threshold selected (ICC1,peak_1) 1B , higher VCC1 active peak threshold selected (ICC1,peak_2)
Reserved	4:2	r	Reserved, always reads as 0
LIN2	1:0	rwh	<b>LIN2-Module Modes</b> 00B , LIN2 OFF 01B , LIN2 is wake capable 10B , LIN2 Receive Only Mode 11B , LIN2 Normal Mode

**Notes**

1. The bit **I\_PEAK\_TH** can be modified in SBC Init and Normal Mode. In SBC Stop Mode this bit is Read only but SPI\_FAIL will not be set when trying to modify the bit in SBC STOP Mode and no INT is triggered in case **INT\_GLOBAL** is set.
2. see **Figure 26** and **Figure 33** for detailed state changes of LIN and CAN Transceiver for different SBC modes
3. Failure Handling Mechanism: When the device enters Fail-Safe Mode due to a failure (TSD2, WD-Failure,...), then the wake registers **BUS\_CTRL\_1**, **BUS\_CTRL\_2** and **WK\_CTRL\_2** are reset to following values (=wake sources) 'xxx0 1001', '0000 0001' and 'x0x0 0111' in order to ensure that the device can be woken again.

## Serial Peripheral Interface

## WK\_CTRL\_1

Internal Wake Input Control (Address 000 0110<sub>B</sub>)POR / Soft Reset Value: 0000 0000<sub>B</sub>;Restart Value: xx00 0000<sub>B</sub>

7	6	5	4	3	2	1	0
TIMER2_WK_EN	TIMER1_WK_EN	Reserved	Reserved	Reserved	WD_STM_EN_1	Reserved	Reserved
rw	rw	r	r	r	rwh	r	r

Field	Bits	Type	Description
TIMER2_WK_EN	7	rw	<b>Timer2 Wake Source Control (for cyclic wake)</b> 0B , Timer2 wake disabled 1B , Timer2 is enabled as a wake source
TIMER1_WK_EN	6	rw	<b>Timer1 Wake Source Control (for cyclic wake)</b> 0B , Timer1 wake disabled 1B , Timer1 is enabled as a wake source
Reserved	5:3	r	<b>Reserved, always reads as 0</b>
WD_STM_EN_1	2	rwh	<b>Watchdog Deactivation during Stop Mode, bit 1 (Chapter 15.2.4)</b> 0B , Watchdog is active in Stop Mode 1B , Watchdog is deactivated in Stop Mode
Reserved	1:0	r	<b>Reserved, always reads as 0</b>

## Serial Peripheral Interface

## WK\_CTRL\_2

External Wake Source Control (Address 000 0111<sub>B</sub>)POR / Soft Reset Value: 0000 0111<sub>B</sub>; Restart Value: x0x0 0xxx<sub>B</sub>

7	6	5	4	3	2	1	0
INT_GLOBAL	Reserved	WK_MEAS	Reserved	Reserved	WK3_EN	WK2_EN	WK1_EN
rw	r	rw	r	r	rw	rw	rw

Field	Bits	Type	Description
<b>INT_GLOBAL</b>	7	rw	<b>Global Interrupt Configuration (see also Chapter 13.1)</b> 0B , Only wake sources trigger INT (default) 1B , All status information register bits will trigger INT (including all wake sources)
<b>Reserved</b>	6	r	<b>Reserved, always reads as 0</b>
<b>WK_MEAS</b>	5	rw	<b>WK / Measurement selection (see also Chapter 12.2.2)</b> 0B , WK functionality enabled for WK1 and WK2 1B , Measurement functionality enabled; WK1 & WK2 are disabled as wake sources, i.e. bits WK1/2_EN bits are ignored
<b>Reserved</b>	4:3	r	<b>Reserved, always reads as 0</b>
<b>WK3_EN</b>	2	rw	<b>WK3 Wake Source Control</b> 0B , WK3 wake disabled 1B , WK3 is enabled as a wake source
<b>WK2_EN</b>	1	rw	<b>WK2 Wake Source Control</b> 0B , WK2 wake disabled 1B , WK2 is enabled as a wake source
<b>WK1_EN</b>	0	rw	<b>WK1 Wake Source Control</b> 0B , WK1 wake disabled 1B , WK1 is enabled as a wake source

## Notes

1. WK\_MEAS is by default configured for standard WK functionality (WK1 and WK2). The bits WK1\_EN and WK2\_EN are ignored in case WK\_MEAS is activated. If the bit is set to '1' then the measurement function is enabled during Normal Mode & the bits WK1\_EN and WK2\_EN are ignored. The bits WK1/"\_LVL bits need to be ignored as well.
2. The wake sources LINx and CAN are selected in the register **BUS\_CTRL\_1** and **BUS\_CTRL\_2** by setting the respective bits to 'wake capable'
3. Failure Handling Mechanism: When the device enters Fail-Safe Mode due to a failure (TSD2, WD-Failure,...), then the wake registers **BUS\_CTRL\_1**, **BUS\_CTRL\_2** and **WK\_CTRL\_2** are reset to following values (=wake sources) 'xxx0 1001', '0000 0001' and 'x0x0 0111' in order to ensure that the device can be woken again.

## Serial Peripheral Interface

## WK\_PUPD\_CTRL

Wake Input Level Control (Address 000 1000<sub>B</sub>)POR / Soft Reset Value: 0000 0000<sub>B</sub>;Restart Value: 00xx xxxx<sub>B</sub>

7	6	5	4	3	2	1	0
Reserved	Reserved	WK3_PUPD_1	WK3_PUPD_0	WK2_PUPD_1	WK2_PUPD_0	WK1_PUPD_1	WK1_PUPD_0
r	r	rw	rw	rw	rw	rw	rw

Field	Bits	Type	Description
Reserved	7:6	r	Reserved, always reads as 0
WK3_PUPD	5:4	rw	<b>WK3 Pull-Up / Pull-Down Configuration</b> 00B , No pull-up / pull-down selected 01B , Pull-down resistor selected 10B , Pull-up resistor selected 11B , Automatic switching to pull-up or pull-down
WK2_PUPD	3:2	rw	<b>WK2 Pull-Up / Pull-Down Configuration</b> 00B , No pull-up / pull-down selected 01B , Pull-down resistor selected 10B , Pull-up resistor selected 11B , Automatic switching to pull-up or pull-down
WK1_PUPD	1:0	rw	<b>WK1 Pull-Up / Pull-Down Configuration</b> 00B , No pull-up / pull-down selected 01B , Pull-down resistor selected 10B , Pull-up resistor selected 11B , Automatic switching to pull-up or pull-down

## Serial Peripheral Interface

## WK\_FLT\_CTRL

Wake Input Filter Time Control (Address 000 1001<sub>B</sub>)POR / Soft Reset Value: 0000 0000<sub>B</sub>;Restart Value: 00xx xxxx<sub>B</sub>

7	6	5	4	3	2	1	0
Reserved	Reserved	WK3_FLT_1	WK3_FLT_0	WK2_FLT_1	WK2_FLT_0	WK1_FLT_1	WK1_FLT_0
r	r	rw	rw	rw	rw	rw	rw

Field	Bits	Type	Description
Reserved	7:6	r	Reserved, always reads as 0
WK3_FLT	5:4	rw	<b>WK3 Filter Time Configuration</b> 00B , Configuration A: Filter with 16μs filter time (static sensing) 01B , Configuration B: Filter with 64μs filter time (static sensing) 10B , Configuration C: Filtering at the end of the on-time; a filter time of 16μs (cyclic sensing) is selected, Timer1 11B , Configuration D: Filtering at the end of the on-time; a filter time of 16μs (cyclic sensing) is selected, Timer2
WK2_FLT	3:2	rw	<b>WK2 Filter Time Configuration</b> 00B , Configuration A: Filter with 16μs filter time (static sensing) 01B , Configuration B: Filter with 64μs filter time (static sensing) 10B , Configuration C: Filtering at the end of the on-time; a filter time of 16μs (cyclic sensing) is selected, Timer1 11B , Configuration D: Filtering at the end of the on-time; a filter time of 16μs (cyclic sensing) is selected, Timer2
WK1_FLT	1:0	rw	<b>WK1 Filter Time Configuration</b> 00B , Configuration A: Filter with 16μs filter time (static sensing) 01B , Configuration B: Filter with 64μs filter time (static sensing) 10B , Configuration C: Filtering at the end of the on-time; a filter time of 16μs (cyclic sensing) is selected, Timer1 11B , Configuration D: Filtering at the end of the on-time; a filter time of 16μs (cyclic sensing) is selected, Timer2

*Note:* When selecting a filter time configuration, the user must make sure to also assign the respective timer to at least one HS switch during cyclic sense operation

## Serial Peripheral Interface

## TIMER1\_CTRL

Timer1 Control and Selection (Address 000 1100<sub>B</sub>)POR / Soft Reset Value: 0000 0000<sub>B</sub>;Restart Value: 0000 0000<sub>B</sub>

7	6	5	4	3	2	1	0
Reserved	TIMER1_ ON_2	TIMER1_ ON_1	TIMER1_ ON_0	Reserved	TIMER1_ PER_2	TIMER1_ PER_1	TIMER1_ PER_0
r	rwh	rwh	rwh	r	rwh	rwh	rwh

Field	Bits	Type	Description
Reserved	7	r	Reserved, always reads as 0
TIMER1_ ON	6:4	rwh	<b>Timer1 On-Time Configuration</b> 000B , OFF / Low (timer not running, HSx output is low) 001B , 0.1ms on-time 010B , 0.3ms on-time 011B , 1.0ms on-time 100B , 10ms on-time 101B , 20ms on-time 110B , OFF / HIGH (timer not running, HSx output is high) 111B , reserved
Reserved	3	r	Reserved, always reads as 0
TIMER1_ PER	2:0	rwh	<b>Timer1 Period Configuration</b> 000B , 10ms 001B , 20ms 010B , 50ms 011B , 100ms 100B , 200ms 101B , 1s 110B , 2s 111B , reserved

## Notes

1. A timer must be first assigned and is then automatically activated as soon as the on-time is configured.
2. If cyclic sense is selected and the HS switches are cleared during SBC Restart Mode, then also the timer settings (period and on-time) are cleared to avoid incorrect switch detection.
3. In case the timer are set as wake sources and cyclic sense is running, then both cyclic sense and cyclic wake will be active at the same time.

## Serial Peripheral Interface

## TIMER2\_CTRL

Timer2 Control and selection (Address 000 1101<sub>B</sub>)POR / Soft Reset Value: 0000 0000<sub>B</sub>;Restart Value: 0000 0000<sub>B</sub>

7	6	5	4	3	2	1	0
Reserved	TIMER2_ ON_2	TIMER2_ ON_1	TIMER2_ ON_0	Reserved	TIMER2_ PER_2	TIMER2_ PER_1	TIMER2_ PER_0
r	rwh	rwh	rwh	r	rwh	rwh	rwh

Field	Bits	Type	Description
Reserved	7	r	Reserved, always reads as 0
TIMER2_ ON	6:4	rwh	<b>Timer2 On-Time Configuration</b> 000B , OFF / Low (timer not running, HSx output is low) 001B , 0.1ms on-time 010B , 0.3ms on-time 011B , 1.0ms on-time 100B , 10ms on-time 101B , 20ms on-time 110B , OFF / HIGH (timer not running, HSx output is high) 111B , reserved
Reserved	3	r	Reserved, always reads as 0
TIMER2_ PER	2:0	rwh	<b>Timer2 Period Configuration</b> 000B , 10ms 001B , 20ms 010B , 50ms 011B , 100ms 100B , 200ms 101B , 1s 110B , 2s 111B , reserved

## Notes

1. A timer must be first assigned and is then automatically activated as soon as the on-time is configured.
2. If cyclic sense is selected and the HS switches are cleared during SBC Restart Mode, then also the timer settings (period and on-time) are cleared to avoid incorrect switch detection.



## Serial Peripheral Interface

## SW\_SD\_CTRL

Switch Shutdown Control (Address 001 0000<sub>B</sub>)POR / Soft Reset Value: 0000 0000<sub>B</sub>;Restart Value: 0xxx 0000<sub>B</sub>

7	6	5	4	3	2	1	0
Reserved	HS_OV_SD_EN	HS_UV_SD_EN	HS_OV_UV_REC	Reserved	Reserved	Reserved	Reserved
r	rw	rw	rw	r	r	r	r

Field	Bits	Type	Description
Reserved	7	r	Reserved, always reads as 0
HS_OV_SD_EN	6	rw	<b>Shutdown Disabling of HS1...4 in case of VSHS OV</b> 0B , shutdown enabled in case of VSHS OV 1B , shutdown disabled in case of VSHS OV
HS_UV_SD_EN	5	rw	<b>Shutdown Disabling of HS1...4 in case of VSHS UV</b> 0B , shutdown enabled in case of VSHS UV 1B , shutdown disabled in case of VSHS UV
HS_OV_UV_REC	4	rw	<b>Switch Recovery after Removal of VSHS OV/UV for HS1...4</b> 0B , Switch recovery is disabled 1B , Previous state before VSHS OV/UV is enabled after OV/UV condition is removed
Reserved	3:0	r	Reserved, always reads as 0

## Serial Peripheral Interface

## HS\_CTRL1

High-Side Switch Control 1 (Address 001 0100<sub>B</sub>)POR / Soft Reset Value: 0000 0000<sub>B</sub>;Restart Value: 0000 0000<sub>B</sub>

7	6	5	4	3	2	1	0
Reserved	HS2_2	HS2_1	HS2_0	Reserved	HS1_2	HS1_1	HS1_0
rw	rwh	rwh	rwh	r	rwh	rwh	rwh

Field	Bits	Type	Description
Reserved	7	r	Reserved, always reads as 0
HS2	6:4	rwh	<b>HS2 Configuration</b> 000B , Off 001B , On 010B , Controlled by Timer1 011B , Controlled by Timer2 100B , Controlled by PWM1 101B , Controlled by PWM2 110B , Reserved 111B , Reserved
Reserved	3	r	Reserved, always reads as 0
HS1	2:0	rwh	<b>HS1 Configuration</b> 000B , Off 001B , On 010B , Controlled by Timer1 011B , Controlled by Timer2 100B , Controlled by PWM1 101B , Controlled by PWM2 110B , Reserved 111B , Reserved

Note: The bits for the switches are also reset in case of overcurrent and overtemperature.

---

**Serial Peripheral Interface**
**HS\_CTRL2****High-Side Switch Control 2 (Address 001 0101<sub>B</sub>)****POR / Soft Reset Value: 0000 0000<sub>B</sub>;****Restart Value: 0000 0000<sub>B</sub>**

7	6	5	4	3	2	1	0
<b>Reserved</b>	<b>HS4_2</b>	<b>HS4_1</b>	<b>HS4_0</b>	<b>Reserved</b>	<b>HS3_2</b>	<b>HS3_1</b>	<b>HS3_0</b>
r	rwh	rwh	rwh	r	rwh	rwh	rwh

Field	Bits	Type	Description
<b>Reserved</b>	7	r	<b>Reserved, always reads as 0</b>
<b>HS4</b>	6:4	rwh	<b>HS4 Configuration</b> 000B , Off 001B , On 010B , Controlled by Timer1 011B , Controlled by Timer2 100B , Controlled by PWM1 101B , Controlled by PWM2 110B , Reserved 111B , Reserved
<b>Reserved</b>	3	r	<b>Reserved, always reads as 0</b>
<b>HS3</b>	2:0	rwh	<b>HS3 Configuration</b> 000B , Off 001B , On 010B , Controlled by Timer1 011B , Controlled by Timer2 100B , Controlled by PWM1 101B , Controlled by PWM2 110B , Reserved 111B , Reserved

*Note: The bits for the switches are also reset in case of overcurrent and overtemperature.*

## Serial Peripheral Interface

## GPIO\_CTRL

GPIO Configuration Control (Address 001 0111<sub>B</sub>)POR / Soft Reset Value: 0000 0000<sub>B</sub>;Restart Value: xxxx xxxx<sub>B</sub>

7	6	5	4	3	2	1	0
FO_DC_1	FO_DC_0	GPIO2_2	GPIO2_1	GPIO2_0	GPIO1_2	GPIO1_1	GPIO1_0
rw	rw	rw	rw	rw	rw	rw	rw

Field	Bits	Type	Description
FO_DC	7:6	rw	<b>Duty Cycle Configuration of FO3 (if selected)</b> 00B , 20% 01B , 10% 10B , 5% 11B , 2.5%
GPIO2	5:3	rw	<b>GPIO2 Configuration</b> 000B , FO3 selected 001B , FO3 selected 010B , FO3 selected 011B , FO3 selected 100B , OFF 101B , Wake input enabled (16μs static filter) 110B , Low-Side Switch ON 111B , High-Side Switch ON
GPIO1	2:0	rw	<b>GPIO1 Configuration</b> 000B , FO2 selected 001B , FO2 selected 010B , FO2 selected 011B , FO2 selected 100B , OFF 101B , Wake input enabled (16μs static filter) 110B , Low-Side Switch ON 111B , High-Side Switch ON

*Note:* When selecting a filter time configuration, the user must make sure to also assign the respective timer to at least one HS switch during cyclic sense operation

## Serial Peripheral Interface

**PWM1\_CTRL****PWM1 Configuration Control (Address 001 1000<sub>B</sub>)****POR / Soft Reset Value: 0000 0000<sub>B</sub>;****Restart Value: xxxx xxxx<sub>B</sub>**

7	6	5	4	3	2	1	0
PWM1_DC_7	PWM1_DC_6	PWM1_DC_5	PWM1_DC_4	PWM1_DC_3	PWM1_DC_2	PWM1_DC_1	PWM1_DC_0
rw	rw	rw	rw	rw	rw	rw	rw

Field	Bits	Type	Description
<b>PWM1_DC</b>	7:0	rw	<b>PWM1 Duty Cycle (bit0=LSB; bit7=MSB)</b> 0000 0000B, 100% OFF xxxx xxxx B, ON with DC fraction of 255 1111 1111B, 100% ON

*Note:* The min. On-time during PWM is limited by the actual Ton and Toff time of the respective HS switch, e.g. the PWM setting '000 0001' could not be realized.

**PWM2\_CTRL****PWM2 Configuration Control (Address 001 1001<sub>B</sub>)****POR / Soft Reset Value: 0000 0000<sub>B</sub>;****Restart Value: xxxx xxxx<sub>B</sub>**

7	6	5	4	3	2	1	0
PWM2_DC_7	PWM2_DC_6	PWM2_DC_5	PWM2_DC_4	PWM2_DC_3	PWM2_DC_2	PWM2_DC_1	PWM2_DC_0
rw	rw	rw	rw	rw	rw	rw	rw

Field	Bits	Type	Description
<b>PWM2_DC</b>	7:0	rw	<b>PWM2 Duty Cycle (bit0=LSB; bit7=MSB)</b> 0000 0000B, 100% OFF xxxx xxxxB, ON with DC fraction of 255 1111 1111B, 100% ON

*Note:* The min. On-time during PWM is limited by the actual Ton and Toff time of the respective HS switch, e.g. the PWM setting '000 0001' could not be realized.

## Serial Peripheral Interface

**PWM\_FREQ\_CTRL****PWM Frequency Configuration Control (Address 001 1100<sub>B</sub>)****POR / Soft Reset Value: 0000 0000<sub>B</sub>;****Restart Value: 0000 0x0x<sub>B</sub>**

7	6	5	4	3	2	1	0
Reserved	Reserved	Reserved	Reserved	Reserved	PWM2_FREQ	Reserved	PWM1_FREQ
r	r	r	r	r	rw	r	rw

Field	Bits	Type	Description
Reserved	7:3	r	Reserved, always reads as 0
PWM2_FREQ	2	rw	<b>PWM2 Frequency Selection</b> 0B , 200Hz configuration 1B , 400Hz configuration
Reserved	1	r	Reserved, always reads as 0
PWM1_FREQ	0	rw	<b>PWM1 Frequency Selection</b> 0B , 200Hz configuration 1B , 400Hz configuration

Note: The min. On-time during PWM is limited by the actual Ton and Toff time of the respective HS switch, e.g. the PWM setting '000 0001' could not be realized.

**SYS\_STATUS\_CTRL****System Status Control (Address 001 1110<sub>B</sub>)****POR Value: 0000 0000<sub>B</sub>;****Restart Value/Soft Reset Value: xxxx xxxx<sub>B</sub>**

7	6	5	4	3	2	1	0
SYS_STAT_7	SYS_STAT_6	SYS_STAT_5	SYS_STAT_4	SYS_STAT_3	SYS_STAT_2	SYS_STAT_1	SYS_STAT_0
rw	rw	rw	rw	rw	rw	rw	rw

Field	Bits	Type	Description
SYS_STAT	7:0	rw	<b>System Status Control Byte (bit0=LSB; bit7=MSB)</b> Dedicated byte for system configuration, access only by microcontroller. Cleared after power up and Soft Reset

**Notes**

1. The **SYS\_STATUS\_CTRL** register is an exception for the default values, i.e. it will keep its configured value also after a Soft Reset.
2. This byte is intended for storing system configurations of the ECU by the microcontroller and is only accessible in SBC Normal Mode. The byte is not accessible by the SBC and is also not cleared after Fail-Safe or SBC Restart Mode. It allows the microcontroller to quickly store system configuration without losing the data.

---

## Serial Peripheral Interface

### 16.6 SPI Status Information Registers

READ/CLEAR Operation (see also [Chapter 16.3](#)):

- One 16-bit SPI command consist of two bytes:
  - the 7-bit address and one additional bit for the register access mode and
  - following the data byteThe numbering of following bit definitions refers to the data byte and correspond to the bits D0...D7 and to the SPI bits 8...15 (see also figure).
- There are two different bit types:
  - 'r' = READ: read only bits (or reserved bits)
  - 'rc' = READ/CLEAR: readable and clearable bits
- Reading a register is done byte wise by setting the SPI bit 7 to "0" (= Read Only)
- Clearing a register is done byte wise by setting the SPI bit 7 to "1"
- SPI status registers are in general not cleared or changed automatically (an exception are the [WD\\_FAIL](#) bits). This must be done by the microcontroller via SPI command

The registers are addressed wordwise.

## Serial Peripheral Interface

## 16.6.1 General Status Registers

## SUP\_STAT\_2

Supply Voltage Fail Status (Address 100 0000<sub>B</sub>)POR / Soft Reset Value: 0000 0000<sub>B</sub>;Restart Value: 0x0x xxxx<sub>B</sub>

7	6	5	4	3	2	1	0
Reserved	VS_UV	Reserved	VCC3_OC	VCC3_UV	VCC3_OT	VCC1_OV	VCC1_WARN
r	rc	r	rc	rc	rc	rc	rc

Field	Bits	Type	Description
Reserved	7	r	Reserved, always reads as 0
VS_UV	6	rc	<b>VS Undervoltage Detection (<math>V_{S,UV}</math>)</b> 0B , No VS undervoltage detected 1B , VS undervoltage detected
Reserved	5	r	Reserved, always reads as 0
VCC3_OC	4	rc	<b>VCC3 Overcurrent Detection</b> 0B , No OC 1B , OC detected
VCC3_UV	3	rc	<b>VCC3 Undervoltage Detection</b> 0B , No VCC3 UV detection 1B , VCC3 UV Fail detected
VCC3_OT	2	rc	<b>VCC3 Overtemperature Detection</b> 0B , No overtemperature 1B , VCC3 overtemperature detected
VCC1_OV	1	rc	<b>VCC1 Overvoltage Detection (<math>V_{CC1,OV,r}</math>)</b> 0B , No VCC1 overvoltage warning 1B , VCC1 overvoltage detected
VCC1_WARN	0	rc	<b>VCC1 Undervoltage Prewarning (<math>V_{PW,f}</math>)</b> 0B , No VCC1 undervoltage prewarning 1B , VCC1 undervoltage prewarning detected

## Notes

1. The VCC1 undervoltage prewarning threshold  $V_{PW,f}/V_{PW,r}$  is a fixed threshold and independent of the VCC1 undervoltage reset thresholds.



## Serial Peripheral Interface

## SUP\_STAT\_1

Supply Voltage Fail Status (Address 100 0001<sub>B</sub>)POR / Soft Reset Value: y000 0000<sub>B</sub>;Restart Value: xxxx xx0x<sub>B</sub>

7	6	5	4	3	2	1	0
POR	VSHS_UV	VSHS_OV	VCC2_OT	VCC2_UV	VCC1_SC	VCC1_UV_FS	VCC1_UV
rc	rc	rc	rc	rc	rc	rc	rc

Field	Bits	Type	Description
POR	7	rc	<b>Power-On Reset Detection</b> 0B , No POR 1B , POR occurred
VSHS_UV	6	rc	<b>VSHS Undervoltage Detection (<math>V_{SHS,UV,D}</math>)</b> 0B , No VSHS-UV 1B , VSHS-UV detected
VSHS_OV	5	rc	<b>VSHS Overvoltage Detection (<math>V_{SHS,OVD}</math>)</b> 0B , No VSHS-OV 1B , VSHS-OV detected
VCC2_OT	4	rc	<b>VCC2 Overtemperature Detection</b> 0B , No overtemperature 1B , VCC2 overtemperature detected
VCC2_UV	3	rc	<b>VCC2 Undervoltage Detection (<math>V_{CC2,UV,f}</math>)</b> 0B , No VCC2 undervoltage 1B , VCC2 undervoltage detected
VCC1_SC	2	rc	<b>VCC1 Short to GND Detection (&lt;V<sub>rtx</sub> for t&gt;4ms after switch on)</b> 0B , No short 1B , VCC1 short to GND detected
VCC1_UV_FS	1	rc	<b>VCC1 UV-Detection (due to V<sub>rtx</sub> reset)</b> 0B , No Fail-Safe Mode entry due to 4th consecutive VCC1_UV 1B , Fail-Safe Mode entry due to 4th consecutive VCC1_UV
VCC1_UV	0	rc	<b>VCC1 UV-Detection (due to V<sub>rtx</sub> reset)</b> 0B , No VCC1_UV detection 1B , VCC1 UV-Fail detected

## Notes

1. The MSB of the POR/Soft Reset value is marked as 'y': the default value of the POR bit is set after Power-on reset (POR value = 1000 0000). However it will be cleared after a SBC Soft Reset command (Soft Reset value = 0000 0000).
2. During Sleep Mode, the bits VCC1\_SC, VCC1\_OV and VCC1\_UV will not be set when VCC1 is off
3. The VCC1\_UV bit is never updated in SBC Restart Mode, in SBC Init Mode it is only updated after RO was released for the first time, it is always updated in SBC Normal and Stop Mode, and it is always updated in any SBC modes in a VCC1\_SC condition (after VCC1\_UV = 1 for >4ms).

---

**Serial Peripheral Interface**
**THERM\_STAT****Thermal Protection Status (Address 100 0010<sub>B</sub>)****POR / Soft Reset Value: 0000 0000<sub>B</sub>; Restart Value: 0000 0xxx<sub>B</sub>**

7	6	5	4	3	2	1	0
<b>Reserved</b>	<b>Reserved</b>	<b>Reserved</b>	<b>Reserved</b>	<b>Reserved</b>	<b>TSD2</b>	<b>TSD1</b>	<b>TPW</b>
r	r	r	r	r	rc	rc	rc

Field	Bits	Type	Description
<b>Reserved</b>	7:3	r	<b>Reserved, always reads as 0</b>
<b>TSD2</b>	2	rc	<b>TSD2 Thermal Shut-Down Detection</b> 0B , No TSD2 event 1B , TSD2 OT detected - leading to SBC Fail-Safe Mode
<b>TSD1</b>	1	rc	<b>TSD1 Thermal Shut-Down Detection</b> 0B , No TSD1 fail 1B , TSD1 OT detected
<b>TPW</b>	0	rc	<b>Thermal Pre Warning</b> 0B , No Thermal Pre warning 1B , Thermal Pre warning detected

*Note: TSD1 and TSD2 are not reset automatically, even if the temperature pre warning or TSD1 OT condition is not present anymore. Also TSD2 is not reset.*

## Serial Peripheral Interface

## DEV\_STAT

Device Information Status (Address 100 0011<sub>B</sub>)POR / Soft Reset Value: 0000 0000<sub>B</sub>;Restart Value: xx00 xxxx<sub>B</sub>

7	6	5	4	3	2	1	0
DEV_STAT_1	DEV_STAT_0	Reserved	Reserved	WD_FAIL_1	WD_FAIL_0	SPI_FAIL	FAILURE
rc	rc	r	r	rh	rh	rc	rc

Field	Bits	Type	Description
DEV_STAT	7:6	rc	<b>Device Status before Restart Mode</b> 00B , Cleared (Register must be actively cleared) 01B , Restart due to failure (WD fail, TSD2, VCC1_UV); also after a wake from Fail-Safe Mode 10B , Sleep Mode 11B , Reserved
Reserved	5:4	r	<b>Reserved, always reads as 0</b>
WD_FAIL	3:2	rh	<b>Number of WD-Failure Events (1/2 WD failures depending on CFG)</b> 00B , No WD Fail 01B , 1x WD Fail, FOx activation - Config 2 selected 10B , 2x WD Fail, FOx activation - Config 1 / 3 / 4 selected 11B , Reserved (never reached)
SPI_FAIL	1	rc	<b>SPI Fail Information</b> 0B , No SPI fail 1B , Invalid SPI command detected
FAILURE	0	rc	<b>Activation of Fail Output FO</b> 0B , No Failure 1B , Failure occurred

## Notes

- The bits **DEV\_STAT** show the status of the device before it went through Restart. Either the device came from regular Sleep Mode ('10') or a failure ('01' - SBC Restart or SBC Fail-Safe Mode: WD fail, TSD2 fail, VCC\_UV fail or VCC1\_OV if bit **VCC1\_OV\_RST** is set) occurred. Failure is also an illegal command from SBC Stop to SBC Sleep Mode or going to SBC Sleep Mode without activation of any wake source. Coming from SBC Sleep Mode ('10') will also be shown if there was a trial to enter SBC Sleep Mode without having cleared all wake flags before.
- The **WD\_FAIL** bits are configured as a counter and are the only status bits, which are cleared automatically by the SBC. They are cleared after a successful watchdog trigger and when the watchdog is stopped (also in SBC Sleep and Fail-Safe Mode unless it was reached due to a watchdog failure). See also [Chapter 14.1](#).
- The **SPI\_FAIL** bit is cleared only by SPI command
- In case of Config 2/4 the **WD\_Fail** counter is frozen in case of WD trigger failure until a successful WD trigger.
- If **CFG = '0'** then a 1st watchdog failure will not trigger the FO outputs or the **FAILURE** bit but only force the SBC into SBC Restart Mode.

## Serial Peripheral Interface

**BUS\_STAT\_1****Bus Communication Status (Address 100 0100<sub>B</sub>)****POR / Soft Reset Value: 0000 0000<sub>B</sub>; Restart Value: 0xx0 0xxx<sub>B</sub>**

7	6	5	4	3	2	1	0
Reserved	LIN1_FAIL_1	LIN1_FAIL_0	Reserved	Reserved	CAN_FAIL_1	CAN_FAIL_0	VCAN_UV
r	rc	rc	r	r	rc	rc	rc

Field	Bits	Type	Description
Reserved	7	r	Reserved, always reads as 0
LIN1_FAIL	6:5	rc	<b>LIN1 Failure Status</b> 00B , No error 01B , LIN1 TSD 10B , LIN1_TXD_DOM: TXD dominant time out for more than 20ms 11B , LIN1_BUS_DOM: BUS dominant time out for more than 20ms
Reserved	4:3	r	Reserved, always reads as 0
CAN_FAIL	2:1	rc	<b>CAN Failure Status</b> 00B , No error 01B , CAN TSD 10B , CAN_TXD_DOM: TXD dominant time out for longer than $t_{TXD\_CAN\_TO}$ 11B , CAN_BUS_DOM: BUS dominant time out for longer than $t_{BUS\_CAN\_TO}$
VCAN_UV	0	rc	<b>Undervoltage CAN Bus Supply</b> 0B , Normal operation 1B , CAN Supply undervoltage detected. Transmitter disabled

**Notes**

1. The VCAN\_UV comparator is enabled if the mode bit CAN\_1 = '1', i.e. in CAN Normal or CAN Receive Only Mode.

---

**Serial Peripheral Interface**
**BUS\_STAT\_2****Bus Communication Status (Address 100 0101<sub>B</sub>)****POR / Soft Reset Value: 0000 0000<sub>B</sub>; Restart Value: 0000 0xx0<sub>B</sub>**

7	6	5	4	3	2	1	0
Reserved	Reserved	Reserved	Reserved	Reserved	LIN2_FAIL_1	LIN2_FAIL_0	Reserved
r	r	r	r	r	rc	rc	r

Field	Bits	Type	Description
Reserved	7:3	r	Reserved, always reads as 0
LIN2_FAIL	2:1	rc	<b>LIN2 Failure Status</b> 00B , No error 01B , LIN2 TSD shutdown 10B , LIN2_TXD_DOM: TXD dominant time out for more than 20ms 11B , LIN2_BUS_DOM: BUS dominant time out for more than 20ms
Reserved	0	r	Reserved, always reads as 0

**Note:***CAN and LINx Recovery Conditions:*

- 1.) TXD Time Out: TXD goes High or transmitter is set to wake capable or switched off;
- 2.) Bus dominant time out: Bus will become recessive or transceiver is set to wake capable or switched off.
- 3.) Supply undervoltage: as soon as the threshold is crossed again, i.e.  $V_{SHS} > V_{S\_UV}$  for LINx and  $V_{CAN} > V_{CAN\_UV}$  for CAN
- 4.) In all cases (also for TSD shutdown): to enable the Bus transmission again, TXD needs to be HIGH for a certain time (transmitter enable time).

## Serial Peripheral Interface

## WK\_STAT\_1

Wake-up Source and Information Status (Address 100 0110<sub>B</sub>)POR / Soft Reset Value: 0000 0000<sub>B</sub>;Restart Value: xxxx 0xxx<sub>B</sub>

7	6	5	4	3	2	1	0
LIN2_WU	LIN1_WU	CAN_WU	TIMER_WU	Reserved	WK3_WU	WK2_WU	WK1_WU
rc	rc	rc	rc	r	rc	rc	rc

Field	Bits	Type	Description
LIN2_WU	7	rc	<b>Wake up via LIN2 Bus</b> 0B , No Wake up 1B , Wake up
LIN1_WU	6	rc	<b>Wake up via LIN1 Bus</b> 0B , No Wake up 1B , Wake up
CAN_WU	5	rc	<b>Wake up via CAN Bus</b> 0B , No Wake up 1B , Wake up
TIMER_WU	4	rc	<b>Wake up via TimerX</b> 0B , No Wake up 1B , Wake up
Reserved	3	r	<b>Reserved, always reads as 0</b>
WK3_WU	2	rc	<b>Wake up via WK3</b> 0B , No Wake up 1B , Wake up
WK2_WU	1	rc	<b>Wake up via WK2</b> 0B , No Wake up 1B , Wake up
WK1_WU	0	rc	<b>Wake up via WK1</b> 0B , No Wake up 1B , Wake up

Note: The respective wake source bit will also be set when the device is woken from SBC Fail-Safe Mode

Serial Peripheral Interface

**WK\_STAT\_2**

**Wake-up Source and Information Status (Address 100 0111<sub>B</sub>)**

**POR / Soft Reset Value: 0000 0000<sub>B</sub>;**

**Restart Value: 00xx 0000<sub>B</sub>**

7	6	5	4	3	2	1	0
Reserved	Reserved	GPIO2_WU	GPIO1_WU	Reserved	Reserved	Reserved	Reserved
r	r	rc	rc	r	r	r	r

Field	Bits	Type	Description
Reserved	7:6	r	Reserved, always reads as 0
GPIO2_WU	5	rc	<b>Wake up via GPIO2</b> 0B , No Wake up 1B , Wake up
GPIO1_WU	4	rc	<b>Wake up via GPIO1</b> 0B , No Wake up 1B , Wake up
Reserved	3:0	r	Reserved, always reads as 0

## Serial Peripheral Interface

## WK\_LVL\_STAT

WK Input Level (Address 100 1000<sub>B</sub>)POR / Soft Reset Value: xx00 0xxx<sub>B</sub>; Restart Value: xxxx 0xxx<sub>B</sub>

7	6	5	4	3	2	1	0
SBC_DEV _LVL	CFGP	GPIO2_LVL	GPIO1_LVL	Reserved	WK3_LVL	WK2_LVL	WK1_LVL
r	r	r	r	r	r	r	r

Field	Bits	Type	Description
SBC_DEV_LVL	7	r	<b>Status of SBC Operating Mode at FO3/TEST Pin</b> 0B , User Mode activated 1B , SBC Development Mode activated
CFGP	6	r	<b>Device Configuration Status</b> 0B , No external pull-up resistor connected on INT (Config 2/4) 1B , External pull-up resistor connected on INT (Config 1/3)
GPIO2_LVL	5	r	<b>Status of GPIO2 (if selected as GPIO)</b> 0B , Low Level (=0) 1B , High Level (=1)
GPIO1_LVL	4	r	<b>Status of GPIO1 (if selected as GPIO)</b> 0B , Low Level (=0) 1B , High Level (=1)
Reserved	3	r	<b>Reserved, always reads as 0</b>
WK3_LVL	2	r	<b>Status of WK3</b> 0B , Low Level (=0) 1B , High Level (=1)
WK2_LVL	1	r	<b>Status of WK2</b> 0B , Low Level (=0) 1B , High Level (=1)
WK1_LVL	0	r	<b>Status of WK1</b> 0B , Low Level (=0) 1B , High Level (=1)

*Note:* GPIOx\_LVL is updated in SBC Normal and Stop Mode if configured as wake input, low-side switch or high-side switch.  
In cyclic sense or wake mode, the registers contain the sampled level, i.e. the registers are updated after every sampling. The GPIOs are not capable of cyclic sensing.  
If selected as GPIO then the respective level is shown even if configured as low-side or high-side.



## Serial Peripheral Interface

## HS\_OC\_OT\_STAT

High-Side Switch Overload Status (Address 101 0100<sub>B</sub>)POR / Soft Reset Value: 0000 0000<sub>B</sub>; Restart Value: 0000 xxxx<sub>B</sub>

7	6	5	4	3	2	1	0
Reserved	Reserved	Reserved	Reserved	HS4_OC_OT	HS3_OC_OT	HS2_OC_OT	HS1_OC_OT
r	r	r	r	rc	rc	rc	rc

Field	Bits	Type	Description
Reserved	7:4	r	Reserved, always reads as 0
HS4_OC_OT	3	rc	<b>Overcurrent &amp; Overtemperature Detection HS4</b> 0B , No OC or OT 1B , OC or OT detected
HS3_OC_OT	2	rc	<b>Overcurrent &amp; Overtemperature Detection HS3</b> 0B , No OC or OT 1B , OC or OT detected
HS2_OC_OT	1	rc	<b>Overcurrent &amp; Overtemperature Detection HS2</b> 0B , No OC or OT 1B , OC or OT detected
HS1_OC_OT	0	rc	<b>Overcurrent &amp; Overtemperature Detection HS1</b> 0B , No OC or OT 1B , OC or OT detected

Note: The OC/OT bit might be set for  $V_{POR,f} < VS < 5.5V$  (see also [Chapter 4.2](#))

## Serial Peripheral Interface

## HS\_OL\_STAT

High-Side Switch Open-Load Status (Address 101 0101<sub>B</sub>)POR / Soft Reset Value: 0000 0000<sub>B</sub>; Restart Value: 0000 xxxx<sub>B</sub>

7	6	5	4	3	2	1	0
Reserved	Reserved	Reserved	Reserved	HS4_OL	HS3_OL	HS2_OL	HS1_OL
r	r	r	r	rc	rc	rc	rc

Field	Bits	Type	Description
Reserved	7:4	r	Reserved, always reads as 0
HS4_OL	3	rc	<b>Open-Load Detection HS4</b> 0B , No OL 1B , OL detected
HS3_OL	2	rc	<b>Open-Load Detection HS3</b> 0B , No OL 1B , OL detected
HS2_OL	1	rc	<b>Open-Load Detection HS2</b> 0B , No OL 1B , OL detected
HS1_OL	0	rc	<b>Open-Load Detection HS1</b> 0B , No OL 1B , OL detected

## Serial Peripheral Interface

## 16.6.2 Family and Product Information Register

## FAM\_PROD\_STAT

Family and Product Identification Register (Address 111 1110<sub>B</sub>)POR / Soft Reset Value: 0011 yyyy<sub>B</sub>; Restart Value: 0011 yyyy<sub>B</sub>

7	6	5	4	3	2	1	0
FAM_3	FAM_2	FAM_1	FAM_0	PROD_3	PROD_2	PROD_1	PROD_0
r	r	r	r	r	r	r	r

Field	Bits	Type	Description
FAM	7:4	r	<b>SBC Family Identifier (bit4=LSB; bit7=MSB)</b> 0 001B, Driver SBC Family 0 010B, DC/DC-SBC Family 0 011B, Mid-Range SBC Family 0 100B, Multi-CAN SBC Family 0 101B, Lite-CAN SBC Family 0 111B, Mid-Range+ SBC Family x x xxB, reserved for future products
PROD	3:0	r	<b>SBC Product Identifier (bit0=LSB; bit3=MSB)</b> 0 0 0 1B, reserved 0 1 0 1B, TLE9261QXV33 (VCC1 = 3.3V, no LIN, VCC3, no SWK) 1 0 0 1B, TLE9262QXV33 (VCC1 = 3.3V, 1 LIN, VCC3, no SWK) 1 1 0 1B, TLE9263QXV33 (VCC1 = 3.3V, 2 LIN, VCC3, no SWK)

## Notes

1. The actual default register value after POR, Soft Reset or Restart of PROD will depend on the respective product. Therefore the value 'y' is specified.
2. SWK = Selective Wake feature in CAN Partial Networking standard

## Serial Peripheral Interface

## 16.7 Electrical Characteristics

Table 30 Electrical Characteristics

$V_S = 5.5\text{ V to }28\text{ V}$ ,  $T_j = -40\text{ °C to }+150\text{ °C}$ , all voltages with respect to ground, positive current flowing into pin (unless otherwise specified)

Parameter	Symbol	Values			Unit	Note or Test Condition	Number
		Min.	Typ.	Max.			
<b>SPI frequency</b>							
Maximum SPI frequency	$f_{\text{SPI,max}}$	–	–	4.0	MHz	<sup>1)</sup>	P_16.7.1
<b>SPI Interface; Logic Inputs SDI, CLK and CSN</b>							
H-input Voltage Threshold	$V_{\text{IH}}$	–	–	$0.7 \times V_{\text{CC1}}$	V	–	P_16.7.2
L-input Voltage Threshold	$V_{\text{IL}}$	$0.3 \times V_{\text{CC1}}$	–	–	V	–	P_16.7.3
Hysteresis of input Voltage	$V_{\text{IHY}}$	$0.08 \times V_{\text{CC1}}$	$0.12 \times V_{\text{CC1}}$	$0.5 \times V_{\text{CC1}}$	V	<sup>1)</sup>	P_16.7.4
Pull-up Resistance at pin CSN	$R_{\text{ICSN}}$	20	40	80	k $\Omega$	$V_{\text{CSN}} = 0.7 \times V_{\text{CC1}}$	P_16.7.5
Pull-down Resistance at pin SDI and CLK	$R_{\text{ICLK/SDI}}$	20	40	80	k $\Omega$	$V_{\text{SDI/CLK}} = 0.2 \times V_{\text{CC1}}$	P_16.7.6
Input Capacitance at pin CSN, SDI or CLK	$C_{\text{I}}$	–	10	–	pF	<sup>1)</sup>	P_16.7.7
<b>Logic Output SDO</b>							
H-output Voltage Level	$V_{\text{SDOH}}$	$V_{\text{CC1}} - 0.4$	$V_{\text{CC1}} - 0.2$	–	V	$I_{\text{DOH}} = -1.6\text{ mA}$	P_16.7.8
L-output Voltage Level	$V_{\text{SDOL}}$	–	0.2	0.4	V	$I_{\text{DOL}} = 1.6\text{ mA}$	P_16.7.9
Tristate Leakage Current	$I_{\text{SDOLK}}$	-10	–	10	$\mu\text{A}$	$V_{\text{CSN}} = V_{\text{CC1}}$ ; $0\text{ V} < V_{\text{DO}} < V_{\text{CC1}}$	P_16.7.10
Tristate Input Capacitance	$C_{\text{SDO}}$	–	10	15	pF	<sup>1)</sup>	P_16.7.11
<b>Data Input Timing<sup>1)</sup></b>							
Clock Period	$t_{\text{pCLK}}$	250	–	–	ns	–	P_16.7.12
Clock High Time	$t_{\text{CLKH}}$	125	–	–	ns	–	P_16.7.13
Clock Low Time	$t_{\text{CLKL}}$	125	–	–	ns	–	P_16.7.14
Clock Low before CSN Low	$t_{\text{bef}}$	125	–	–	ns	–	P_16.7.15
CSN Setup Time	$t_{\text{lead}}$	250	–	–	ns	–	P_16.7.16
CLK Setup Time	$t_{\text{lag}}$	250	–	–	ns	–	P_16.7.17
Clock Low after CSN High	$t_{\text{beh}}$	125	–	–	ns	–	P_16.7.18
SDI Set-up Time	$t_{\text{DISU}}$	100	–	–	ns	–	P_16.7.19
SDI Hold Time	$t_{\text{DIHO}}$	50	–	–	ns	–	P_16.7.20
Input Signal Rise Time at pin SDI, CLK and CSN	$t_{\text{rIN}}$	–	–	50	ns	–	P_16.7.21

Serial Peripheral Interface

**Table 30 Electrical Characteristics (cont'd)**

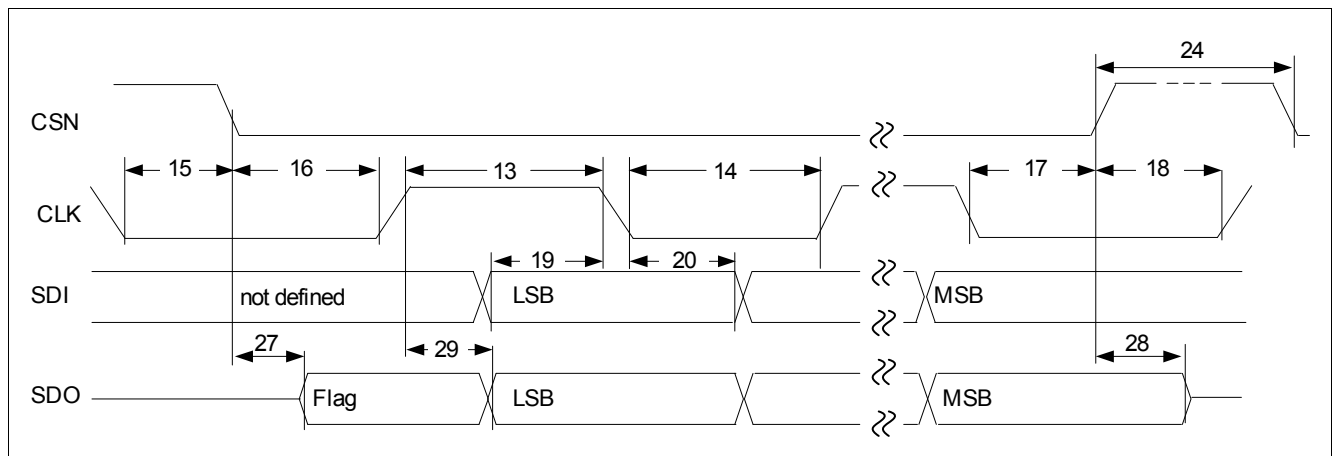
$V_S = 5.5\text{ V to }28\text{ V}$ ,  $T_j = -40\text{ }^\circ\text{C to }+150\text{ }^\circ\text{C}$ , all voltages with respect to ground, positive current flowing into pin (unless otherwise specified)

Parameter	Symbol	Values			Unit	Note or Test Condition	Number
		Min.	Typ.	Max.			
Input Signal Fall Time at pin SDI, CLK and CSN	$t_{fIN}$	-	-	50	ns	-	P_16.7.22
Delay Time for Mode Changes <sup>2)</sup>	$t_{Del,Mode}$	-	-	6	$\mu\text{s}$	includes internal oscillator tolerance	P_16.7.23
CSN High Time	$t_{CSN(high)}$	3	-	-	$\mu\text{s}$	-	P_16.7.24

**Data Output Timing<sup>1)</sup>**

SDO Rise Time	$t_{rSDO}$	-	30	80	ns	$C_L = 100\text{ pF}$	P_16.7.25
SDO Fall Time	$t_{fSDO}$	-	30	80	ns	$C_L = 100\text{ pF}$	P_16.7.26
SDO Enable Time	$t_{ENSDO}$	-	-	50	ns	low impedance	P_16.7.27
SDO Disable Time	$t_{DISSDO}$	-	-	50	ns	high impedance	P_16.7.28
SDO Valid Time	$t_{VASDO}$	-	-	50	ns	$C_L = 100\text{ pF}$	P_16.7.29

- 1) Not subject to production test; specified by design
- 2) Applies to all mode changes triggered via SPI commands



**Figure 58 SPI Timing Diagram**

*Note: Numbers in drawing correlate to the last 2 digits of the Number field in the Electrical Characteristics table.*

Application Information

17 Application Information

17.1 Application Diagram

Note: The following information is given as a hint for the implementation of the device only and shall not be regarded as a description or warranty of a certain functionality, condition or quality of the device.

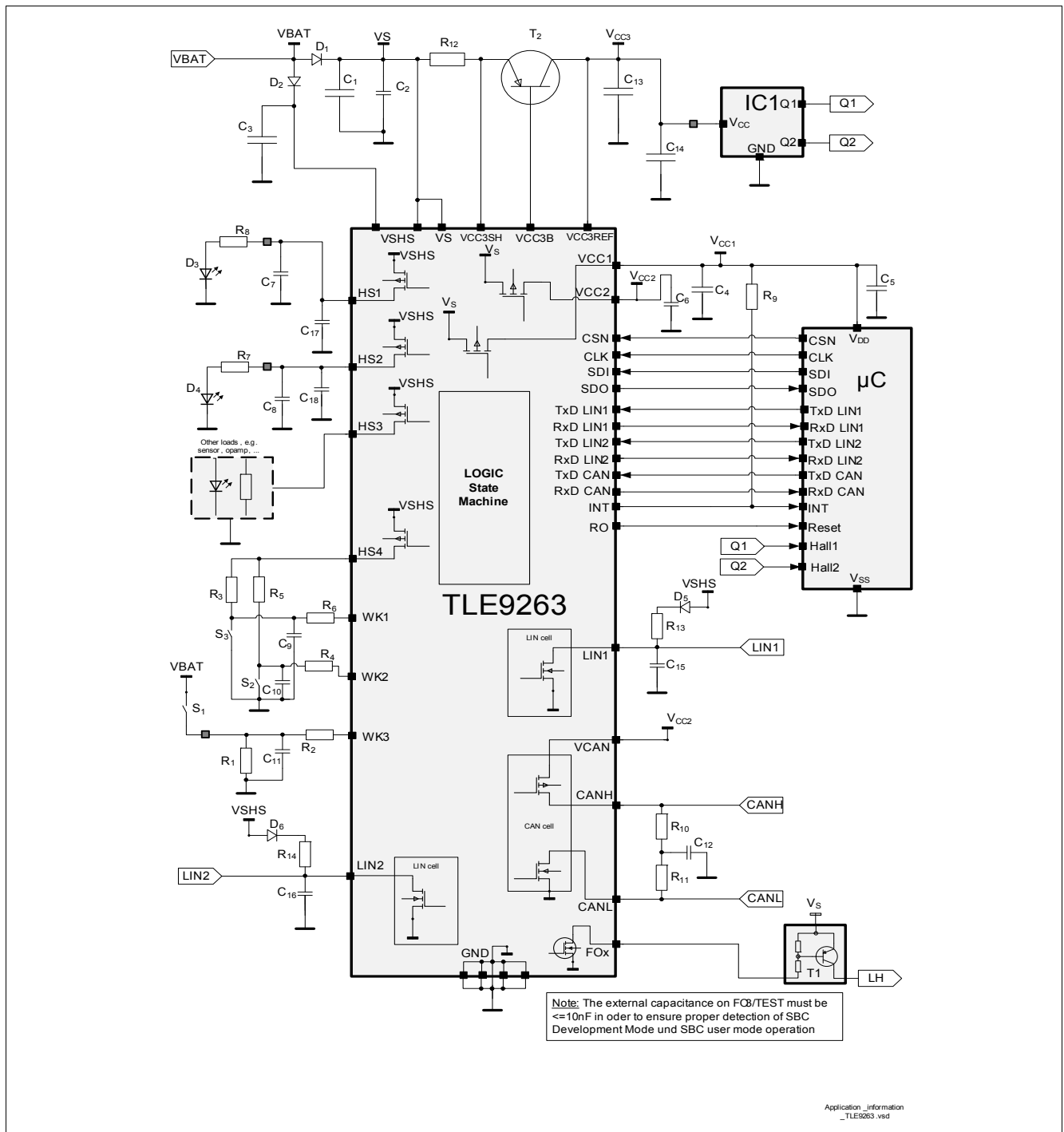


Figure 59 Simplified Application Diagram

## Application Information

*Note: Unused outputs are recommended to be left unconnected on the application board. If unused output pins are routed to an external connector which leaves the ECU, then these pins should have provision for a zero ohm jumper (depopulated if unused) or ESD protection.*

**Table 31 Bill of Material for Simplified Application Diagram**

Ref.	Typical Value	Purpose / Comment
<b>Capacitances</b>		
C1	68 $\mu$ F	Buffering capacitor to cut off battery spikes, depending on application
C2	100nF	EMC, blocking capacitor
C3	22 $\mu$ F	Buffering capacitor to cut off battery spikes from VSHS as separate supply input; Depending on application, only needed if VSHS is not connected to VS;
C4	2.2 $\mu$ F low ESR	As required by application, min. 470nF for stability and max. 68 $\mu$ F recommended
C5	100nF ceramic	Spike filtering, improve stability of supply for microcontroller; not needed for SBC
C6	2.2 $\mu$ F low ESR	Blocking capacitor, min. 470nF for stability; if used for CAN supply place a 100nF ceramic capacitor in addition very close to VCAN pin for optimum EMC behavior
C7	33nF	As required by application, mandatory protection for off-board connections
C8	33nF	As required by application, mandatory protection for off-board connections
C17	47pF	Only required in case of off-board connection to optimize EMC behavior, place close to pin
C18	47pF	Only required in case of off-board connection to optimize EMC behavior, place close to pin
C9	10nF	Spike filtering, as required by application, mandatory protection for off-board connections (see also Simplified Application Diagram with the Alternate Measurement Function)
C10	10nF	Spike filtering, as required by application, mandatory protection for off-board connections
C11	10nF	Spike filtering, as required by application, mandatory protection for off-board connections
C12	4.7nF / OEM dependent	Split termination stability
C13	10 $\mu$ F low ESR	Stability of VCC3, ceramic capacitor, e.g. Murata 10 $\mu$ F/10 V GCM31CR71A106K64L or 2x 4.7 $\mu$ F/10 V
C14	47nF	Only required in case of off-board connection to optimize EMC behavior, place close to connector
C15	1nF / OEM dependent	LIN master termination
C16	1nF / OEM dependent	LIN master termination
<b>Resistances</b>		
R1	10k $\Omega$	Wetting current of the switch, as required by application

## Application Information

**Table 31 Bill of Material for Simplified Application Diagram (cont'd)**

Ref.	Typical Value	Purpose / Comment
R2	10k $\Omega$	Limit the WK pin current, e.g. for ISO pulses
R3	10k $\Omega$	Wetting current of the switch, as required by application
R4	10k $\Omega$	Limit the WK pin current, e.g. for ISO pulses
R5	10k $\Omega$	Wetting current of the switch, as required by application
R6	10k $\Omega$	Limit the WK pin current, e.g. for ISO pulses
R7	depending on LED config.	LED current limitation, as required by application
R8	depending on LED config.	LED current limitation, as required by application
R9	47k $\Omega$	Selection of hardware configuration 1/3, i.e. in case of WD failure SBC Restart Mode is entered. If not connected, then hardware configuration 2/4 is selected
R10	60 $\Omega$ / OEM dependent	CAN bus termination
R11	60 $\Omega$ / OEM dependent	CAN bus termination
R12	1 $\Omega$ shunt, depending on required current limitation or load sharing ratio	Sense shunt for ICC3 current limitation (configured to typ. 235mA with 1 $\Omega$ shunt) for stand-alone configuration; Setting of load sharing ratio (here ICC3/ICC1 = 1) in load sharing configuration.
R13	1k $\Omega$ / OEM dependent	LIN master termination (if configured as a LIN master)
R14	1k $\Omega$ / OEM dependent	LIN master termination (if configured as a LIN master)
R15	10k $\Omega$	WK1 pin current limitation, e.g. for ISO pulses, for alternate measurement function (see also Simplified Application Diagram with the Alternate Measurement Function)
R16	depending on application and microcontroller	Voltage Divider resistor to adjust measurement voltage to microcontroller ADC input range (see also Simplified Application Diagram with the Alternate Measurement Function)
R17	depending on application and microcontroller	Voltage Divider resistor to adjust measurement voltage to microcontroller ADC input range (see also Simplified Application Diagram with the Alternate Measurement Function)

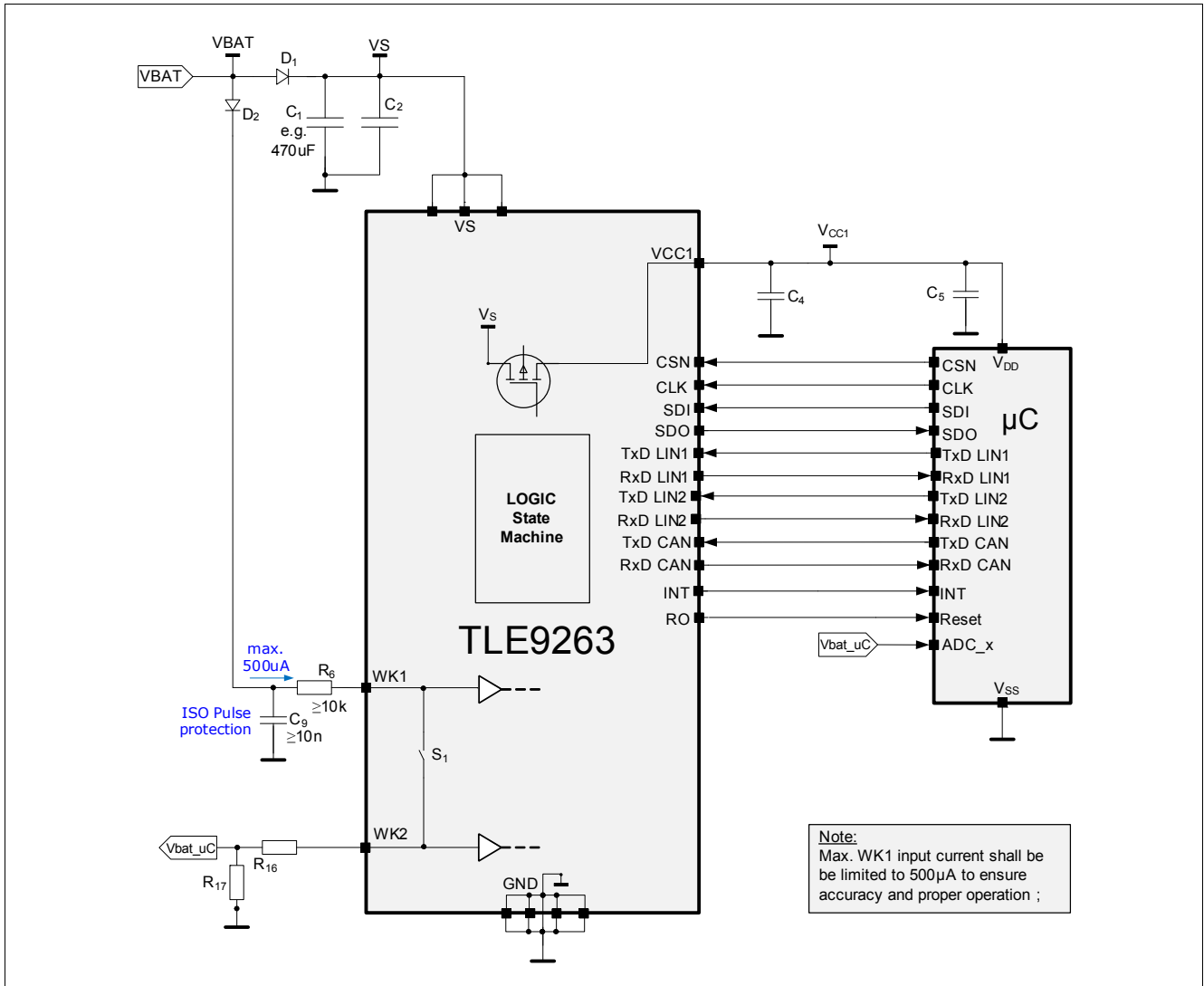
### Active Components

D1	e.g. BAS 3010A, Infineon	Reverse polarity protection for VS supply pins
D2	e.g. BAS 3010A, Infineon	Reverse polarity protection for VSHS supply pin; if separate supplies are not needed, then connect VSHS to VS pins
D3	LED	As required by application, configure series resistor accordingly
D4	LED	As required by application, configure series resistor accordingly
D5	e.g. BAS70	Requested by LIN standard; reverse polarity protection of network
D6	e.g. BAS70	Requested by LIN standard; reverse polarity protection of network
T1	e.g. BCR191W	High active FO control
T2	BCP 52-16, Infineon	Power element of VCC3, current limit or load sharing ratio to be configured via shunt
	MJD 253, ON Semi	Alternative power element of VCC3
$\mu$ C	e.g. TC2xxx	Microcontroller



**Application Information**

*Note: This is a simplified example of an application circuit. The function must be verified in the real application.*



**Figure 60 Simplified Application Diagram with the Alternate Measurement Function via WK1 and WK2**

*Note: This is a very simplified example of an application circuit. The function must be verified in the real application. WK1 must be connected to signal to be measured and WK2 is the output to the microcontroller supervision function. The maximum current into WK1 must be <500µA. The minimum current into WK1 should be >5µA to ensure proper operation.*

Application Information

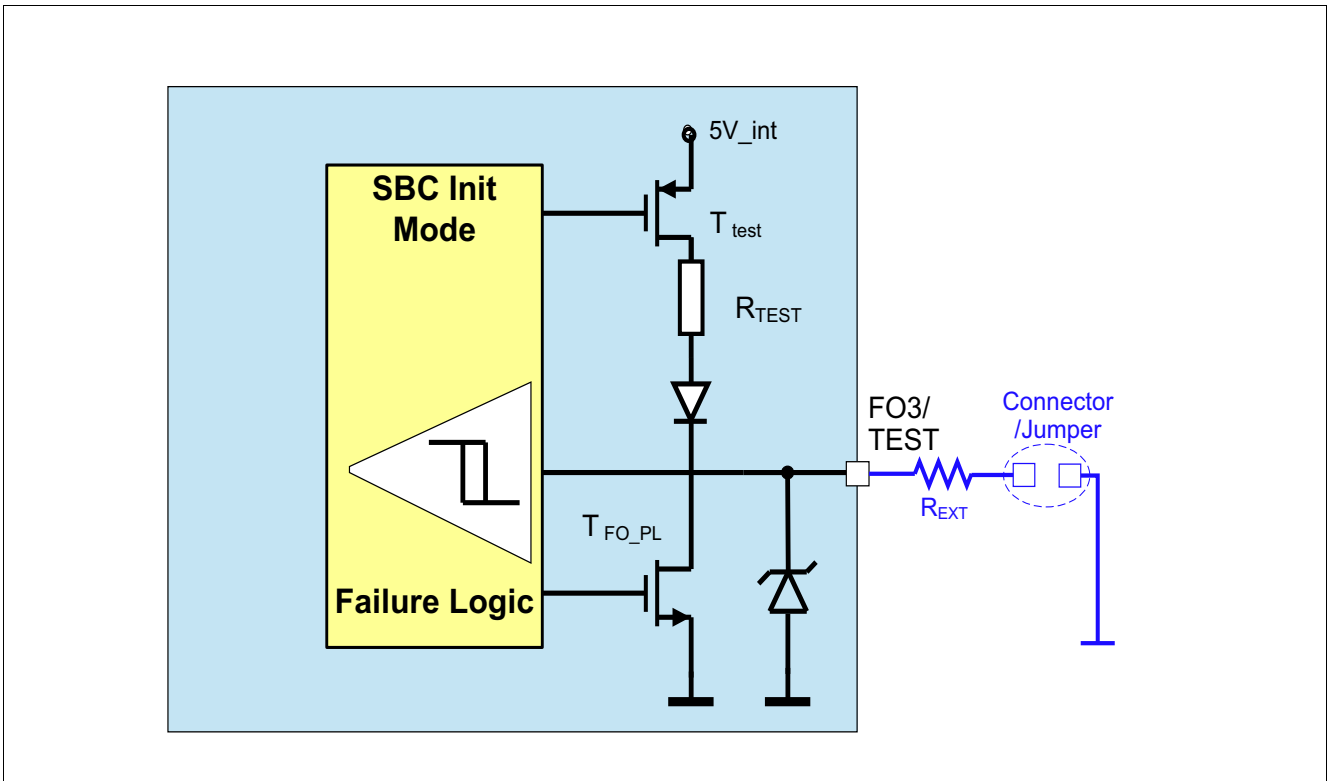


Figure 61 Hint for Increasing the Robustness of pin FO3/TEST during Debugging or Programming

## Application Information

### 17.2 ESD Tests

*Note:* Tests for ESD robustness according to IEC61000-4-2 “gun test” (150pF, 330Ω) has been performed. The results and test conditions are available in a test report. The target values for the test are listed in [Table 32](#) below.

**Table 32 ESD “Gun Test”**

Performed Test	Result	Unit	Remarks
ESD at pin CANH, CANL, LIN, VS, WK1..3, HSx, VCC2, VCC3 versus GND	>6	kV	<sup>1)2)</sup> positive pulse
ESD at pin CANH, CANL, LIN, VS, WK1..3, HSx, VCC2, VCC3 versus GND	< -6	kV	<sup>1)2)</sup> negative pulse

- 1) ESD Test “Gun Test” is specified with external components for pins VS, WK1..3, HSx, VCC3 and VCC2. See the application diagram in [Chapter 17.1](#) for more information.
- 2) ESD susceptibility “ESD GUN” according LIN EMC 1.3 Test Specification, Section 4.3 (IEC 61000-4-2). Tested by external test house (IBEE Zwickau, EMC Test report Nr. 04-01-17)

EMC and ESD susceptibility tests according to SAE J2962-2 (2010) have been performed. Tested by external test house (UL LLC).

Application Information

17.3 Thermal Behavior of Package

Below figure shows the thermal resistance ( $R_{th\_JA}$ ) of the device vs. the cooling area on the bottom of the PCB for  $T_a = 85^\circ\text{C}$ . Every line reflects a different PCB and thermal via design.

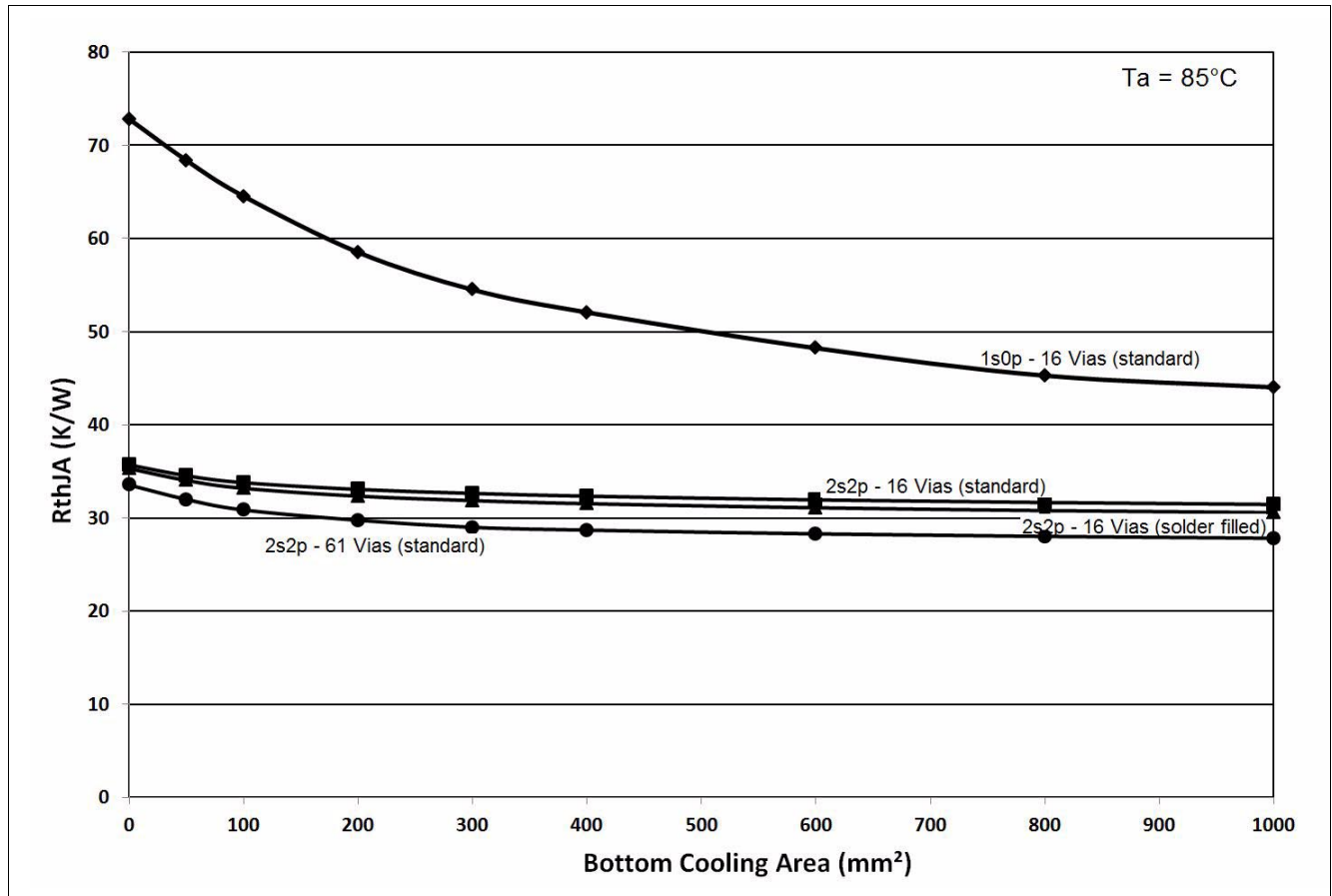


Figure 62 Thermal Resistance ( $R_{th\_JA}$ ) vs. Cooling Area

Application Information

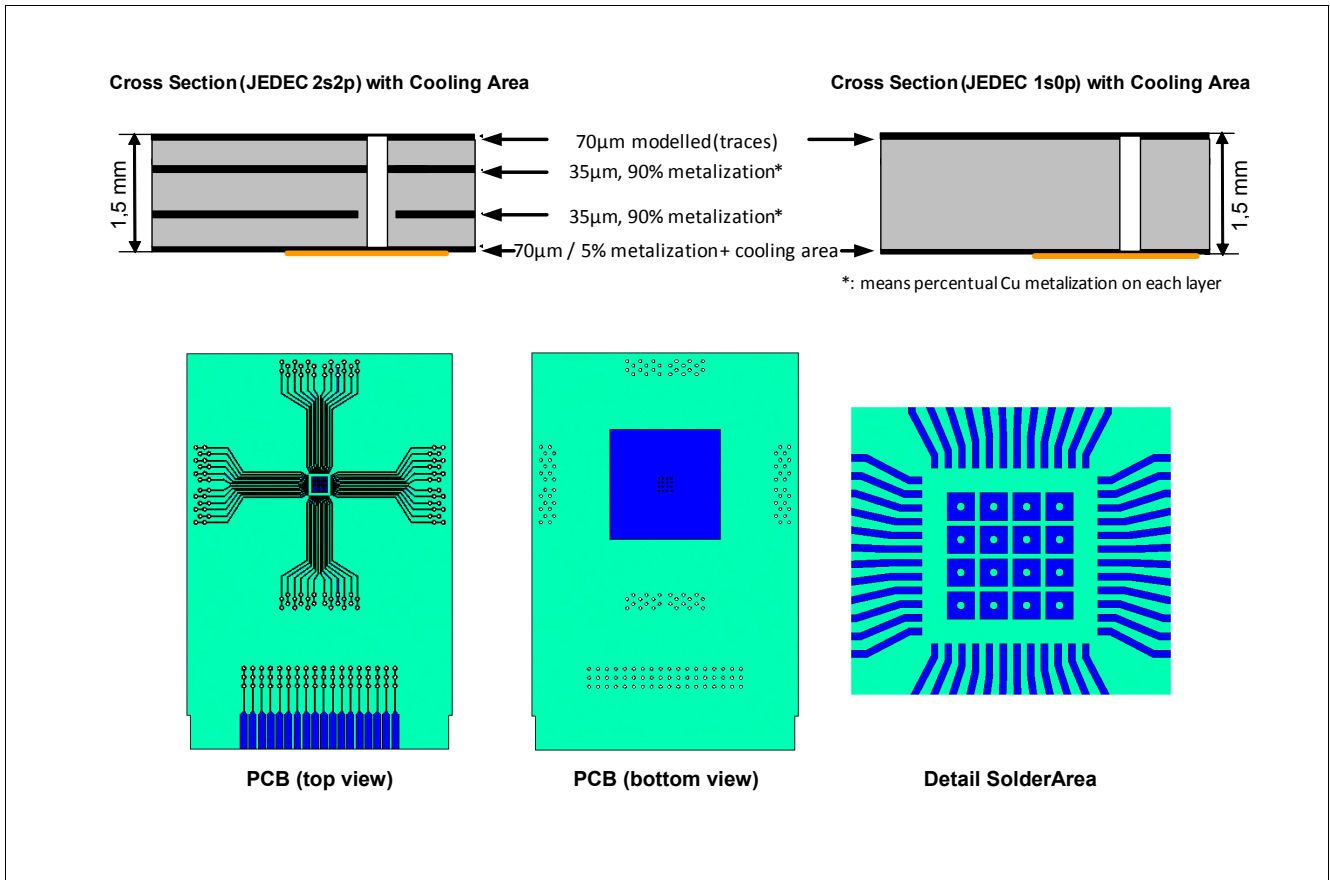


Figure 63 Board Setup

Board setup is defined according to JESD 51-2,-5,-7.

Board: 76.2x114.3x1.5mm<sup>3</sup> with 2 inner copper layers (35µm thick), with thermal via array under the exposed pad contacting the first inner copper layer and 300mm<sup>2</sup> cooling area on the bottom layer (70µm).

## Package Outlines

## 18 Package Outlines

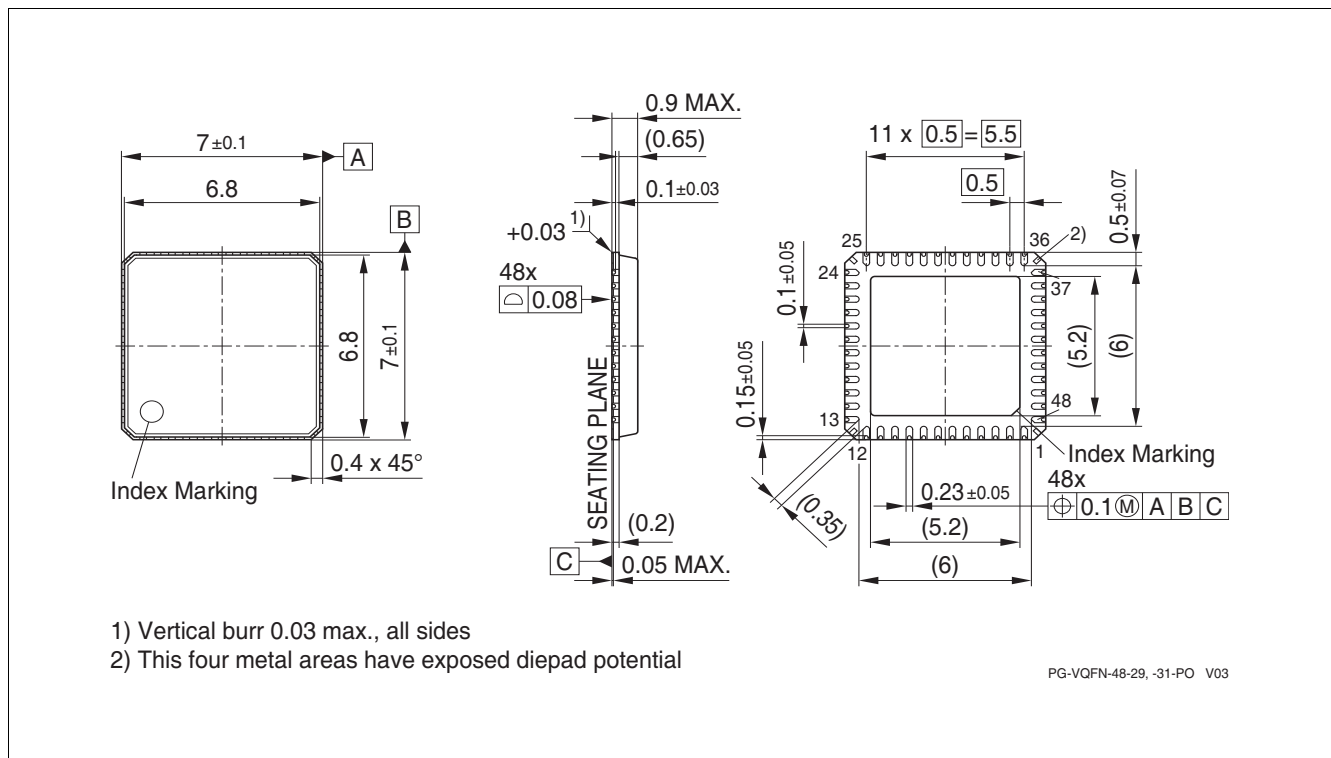


Figure 64 PG-VQFN-48-31

Note: *Dimensions in mm.*  
*The tie bars have an internal connection to the exposed pad.*  
*For assembly recommendations please also refer to the documents "Recommendations for Board Assembly (VQFN and IQFN)" and "VQFN48 Layout Hints" on the Infineon website ([www.infineon.com](http://www.infineon.com)).*

The PG-VQFN-48-31 package is a leadless exposed pad power package featuring Lead Tip Inspection (LTI) to support Automatic Optical Inspection (AOI).

**Green Product (RoHS compliant)**

To meet the world-wide customer requirements for environmentally friendly products and to be compliant with government regulations the device is available as a green product. Green products are RoHS-Compliant (i.e Pb-free finish on leads and suitable for Pb-free soldering according to IPC/JEDEC J-STD-020).

For further information on alternative packages, please visit our website:  
<http://www.infineon.com/packages>.

Dimensions in mm

---

**Revision History****19 Revision History**

<b>Revision</b>	<b>Date</b>	<b>Changes</b>
Rev. 1.00	2017-07-31	Initial Release

#### Trademarks of Infineon Technologies AG

$\mu$ HVIC™,  $\mu$ IPM™,  $\mu$ PFC™, AU-ConvertIR™, AURIX™, C166™, CanPAK™, CIPOS™, CIPURSE™, CoolDP™, CoolGaN™, COOLiR™, CoolMOS™, CoolSET™, CoolSiC™, DAVE™, DI-POL™, DirectFET™, DrBlade™, EasyPIM™, EconoBRIDGE™, EconoDUAL™, EconoPACK™, EconoPIM™, EiceDRIVER™, eupec™, FCOS™, GaNpowIR™, HEXFET™, HITFET™, HybridPACK™, iMOTION™, IRAM™, ISOFACE™, IsoPACK™, LEDriviR™, LITIX™, MIPAQ™, ModSTACK™, my-d™, NovalithIC™, OPTIGA™, OptiMOS™, ORIGA™, PowIRaudio™, PowIRstage™, PrimePACK™, PrimeSTACK™, PROFET™, PRO-SIL™, RASIC™, REAL3™, SmartLEWIS™, SOLID FLASH™, SPOC™, StrongIRFET™, SupIRBuck™, TEMPFET™, TRENCHSTOP™, TriCore™, UHVIC™, XHP™, XMC™.

Trademarks updated November 2015

#### Other Trademarks

All referenced product or service names and trademarks are the property of their respective owners.

**Edition 2017-07-31**

**Published by**

**Infineon Technologies AG**

**81726 Munich, Germany**

**© 2017 Infineon Technologies AG.**

**All Rights Reserved.**

**Do you have a question about any aspect of this document?**

**Email: [erratum@infineon.com](mailto:erratum@infineon.com)**

#### IMPORTANT NOTICE

The information given in this document shall in no event be regarded as a guarantee of conditions or characteristics ("Beschaffheitsgarantie").

With respect to any examples, hints or any typical values stated herein and/or any information regarding the application of the product, Infineon Technologies hereby disclaims any and all warranties and liabilities of any kind, including without limitation warranties of non-infringement of intellectual property rights of any third party.

In addition, any information given in this document is subject to customer's compliance with its obligations stated in this document and any applicable legal requirements, norms and standards concerning customer's products and any use of the product of Infineon Technologies in customer's applications.

The data contained in this document is exclusively intended for technically trained staff. It is the responsibility of customer's technical departments to evaluate the suitability of the product for the intended application and the completeness of the product information given in this document with respect to such application.

For further information on technology, delivery terms and conditions and prices, please contact the nearest Infineon Technologies Office ([www.infineon.com](http://www.infineon.com)).

#### WARNINGS

Due to technical requirements products may contain dangerous substances. For information on the types in question please contact your nearest Infineon Technologies office.

Except as otherwise explicitly approved by Infineon Technologies in a written document signed by authorized representatives of Infineon Technologies, Infineon Technologies' products may not be used in any applications where a failure of the product or any consequences of the use thereof can reasonably be expected to result in personal injury.



# Mouser Electronics

Authorized Distributor

Click to View Pricing, Inventory, Delivery & Lifecycle Information:

[Infineon:](#)

[TLE9263BQXV33XUMA1](#)



Компания «ЭлектроПласт» предлагает заключение долгосрочных отношений при поставках импортных электронных компонентов на взаимовыгодных условиях!

Наши преимущества:

- Оперативные поставки широкого спектра электронных компонентов отечественного и импортного производства напрямую от производителей и с крупнейших мировых складов;
- Поставка более 17-ти миллионов наименований электронных компонентов;
- Поставка сложных, дефицитных, либо снятых с производства позиций;
- Оперативные сроки поставки под заказ (от 5 рабочих дней);
- Экспресс доставка в любую точку России;
- Техническая поддержка проекта, помощь в подборе аналогов, поставка прототипов;
- Система менеджмента качества сертифицирована по Международному стандарту ISO 9001;
- Лицензия ФСБ на осуществление работ с использованием сведений, составляющих государственную тайну;
- Поставка специализированных компонентов (Xilinx, Altera, Analog Devices, Intersil, Interpoint, Microsemi, Aeroflex, Peregrine, Syfer, Eurofarad, Texas Instrument, Miteq, Cobham, E2V, MA-COM, Hittite, Mini-Circuits, General Dynamics и др.);

Помимо этого, одним из направлений компании «ЭлектроПласт» является направление «Источники питания». Мы предлагаем Вам помощь Конструкторского отдела:

- Подбор оптимального решения, техническое обоснование при выборе компонента;
- Подбор аналогов;
- Консультации по применению компонента;
- Поставка образцов и прототипов;
- Техническая поддержка проекта;
- Защита от снятия компонента с производства.



#### Как с нами связаться

**Телефон:** 8 (812) 309 58 32 (многоканальный)

**Факс:** 8 (812) 320-02-42

**Электронная почта:** [org@eplast1.ru](mailto:org@eplast1.ru)

**Адрес:** 198099, г. Санкт-Петербург, ул. Калинина, дом 2, корпус 4, литера А.