

SMA Series Subminiature RF Connectors

ONLINE
CATALOG

Screw-on mating

Frequency range DC-18 GHz

High performance

Rugged construction



APPLIED ENGINEERING PRODUCTS

104 John W. Murphy Drive • P.O. Box 510 • New Haven, CT 06513

(203) 776-2813 • FAX (203) 776-8294

www.aepconnectors.com • e-mail: aepsales@aepconnectors.com

SMA Subminiature Connectors

Click on any line below to go directly to the appropriate page

Contents

Technical Information

Interfaces and specifications	3
Cable attachment methods	4

Cable Connectors

Plugs for semi-rigid cable	6
Plugs for flexible cable	8
Jacks for semi-rigid cable	10
Jacks for flexible cable	11
Bulkhead jacks for semi-rigid cable	12
Bulkhead jacks for flexible cable	13
Panel jacks for semi-rigid cable	14
Panel jacks for flexible cable	15

Receptacles

Panel jack receptacles	16
Receptacles for .025" microstrip	21
Receptacles for .010" microstrip	22
Panel plug receptacles	23
Bulkhead jack receptacles	26
Knurl mount receptacles	28
P.C. board receptacles	29
Stripline receptacles	30
Hermetic seal launchers	31

Adapters

Straight adapters within series	46
Right angle adapters within series	47
Tee adapters within series	48

Resistive Terminations

Plug resistive termination	48
--------------------------------------	----

Cable Assembly Instructions

Connectors for flexible cable	49
Connectors for semi-rigid cable	52

Assembly Tooling

Assembly Tooling	55
----------------------------	----

Mounting Dimensions

Mounting Dimensions	55
-------------------------------	----

Index by AEP Part Number

Index by AEP Part Number	56
------------------------------------	----

About AEP

About AEP	59
---------------------	----

Other AEP Product Lines

Other AEP Product Lines	60
-----------------------------------	----



APPLIED ENGINEERING PRODUCTS

104 John W. Murphy Drive • P.O. Box 510 • New Haven, CT 06513

(203) 776-2813 • FAX (203) 776-8294

www.aepconnectors.com • e-mail: aepsales@aepconnectors.com

SMA Connectors

AEP SMA connectors are available with gold-plated bodies, or with passivated or nickel-plated bodies for greater economy. The coupling nuts of plug connectors are passivated in all cases.

Our unique mechanical captivation method (see page 5) greatly reduces RF leakage by eliminating epoxy fill holes in the connector body.

Specifications (MIL-PRF-39012 as applicable)

Materials:

Body components: Stainless steel per ASTM-A-582, type 303.

Contacts: Beryllium copper per ASTM-B-196, Condition HT.

Insulators: Teflon TFE per ASTM-D-1710.

Gaskets: Silicone rubber per ZZ-R-765, Class 2B, grade 65-75.

Finish:

Center contacts: Gold plated per current revision of MIL-PRF-39012*

Other metal parts: Gold plated, passivated, or nickel plated to meet current MIL-PRF-39012 corrosion requirements.*

Electrical:

VSWR Straight cable plugs and jacks:

Cable	VSWR	Frequency
RG-178	$1.20 + (.025 \times F[\text{GHz}])$	DC-12.4 GHz
RG-316	$1.15 + (.020 \times F[\text{GHz}])$	DC-12.4 GHz
RG-142	$1.15 + (.010 \times F[\text{GHz}])$	DC-12.4 GHz
RG-402 ⁽¹⁾	$1.05 + (.008 \times F[\text{GHz}])$	DC-18 GHz
RG-402 ⁽²⁾	$1.05 + (.010 \times F[\text{GHz}])$	DC-18 GHz
RG-405 ⁽¹⁾	$1.07 + (.008 \times F[\text{GHz}])$	DC-18 GHz
RG-405 ⁽²⁾	$1.07 + (.010 \times F[\text{GHz}])$	DC-18 GHz

⁽¹⁾ Non-captive contact. ⁽²⁾ Captive contact.

VSWR specifications not applicable to non-cabled connectors.

Impedance: 50Ω.

Frequency range: DC-8, 12.4, or 18 GHz (varies with cable type).

Insulation Resistance: 5,000 megohms minimum.

*These specifications change periodically with updates to MIL-PRF-39012 requirements. Contact factory for latest specifications.

Electrical (continued):

Voltage Rating: 250VRMS @ sea level (RG-178 cable); 335VRMS @ sea level (RG-316 cable).

Dielectric Withstanding Voltage: Per MIL-STD-202, Method 301.

Contact Resistance: 3 milliohms maximum.

RF highpot: 335-675 VRMS @ 5-7.5 MHz (varies with cable type).

RF leakage: -60 dB min @ 2-3 GHz.

Insertion loss: .44 dB max to 6 GHz.

Mechanical:

Force to engage/disengage: 2 pounds max.

Force to engage/disengage (female contacts):

(After 5 insertions of .375" diameter pin, .040" min depth)

Insertion force for .037 min diameter pin, 2 pounds max.

Withdrawal force for .0355" max diameter pin, 1 ounce min.

Contact retention: 6 pounds min axial force (captive types).

Durability: 500 mating cycles.

Environmental (MIL-STD-202):

Temperature range: -65° C to +165° C.

Corrosion: Method 101, condition B, 5% salt solution.

Vibration (Method 204): Condition B.

Mechanical shock (Method 213): Condition B.

Thermal shock (Method 107): Condition B.

Interface Dimensions

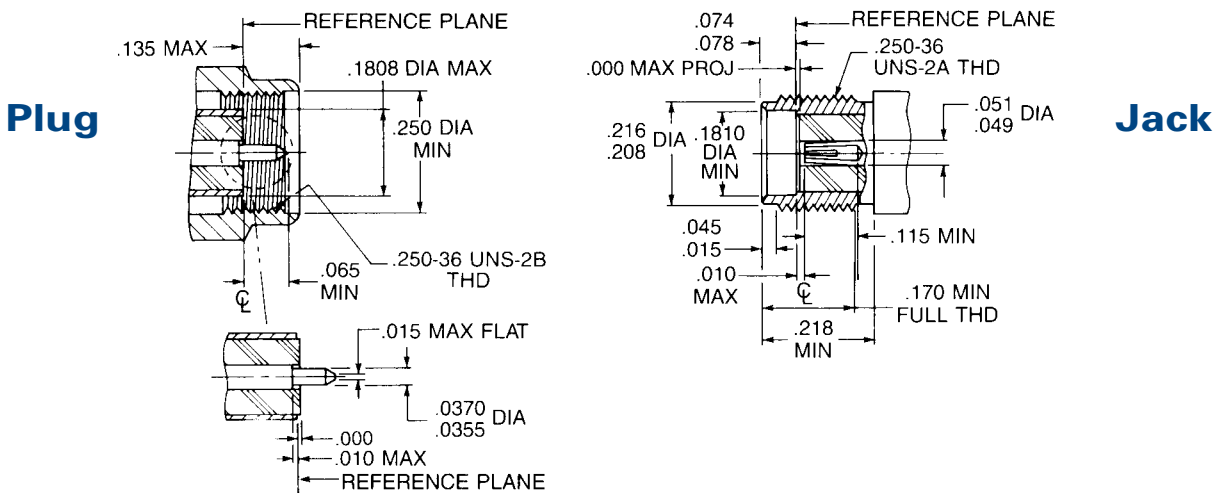

APPLIED ENGINEERING PRODUCTS

(203) 776-2813 • FAX (203) 776-8294

www.aepconnectors.com • aepsales@aepconnectors.com

SMA Cable Attachment Methods

Semi-Rigid Cable

Direct Solder (cable center conductor used as contact): This type of cable attachment ensures the best possible electrical performance because there are no discontinuities introduced by contact geometry changes. It is best used in applications **not** requiring frequent mating and unmating, because the pointed center conductor and exposed cable jacket will shed metal chips when mated with SMA female connectors.

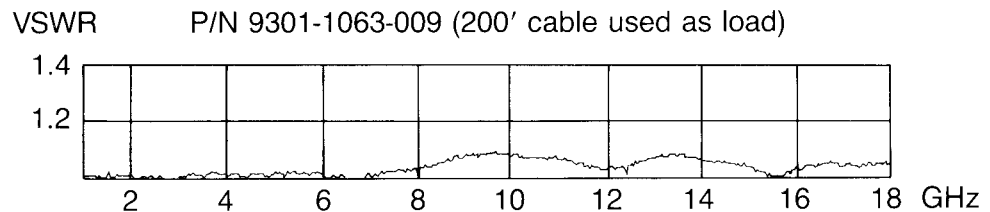
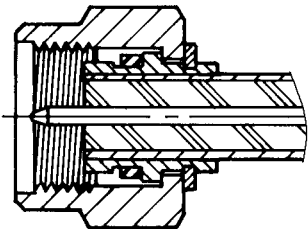

Direct Solder (with contact and insulator): Although this cable attachment exhibits higher VSWR than types without contacts, it provides an outer conductor that does not have the copper cable jacket exposed to mating forces. This, along with the beryllium-copper contact, ensures clean interfaces through many mating cycles.

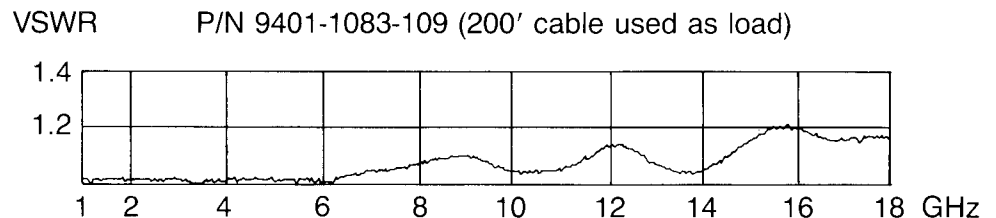
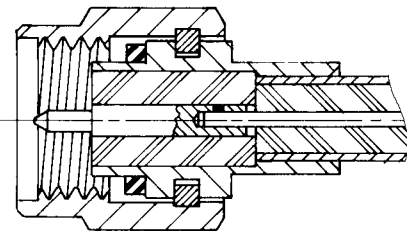

Direct Solder (with captive contact): These connectors have electrical performance similar to types with non-captive contacts, but with faster and easier cable assembly. The cable is simply stripped and inserted into the connector, and the cable jacket soldered to the connector. The proper contact gap is automatically maintained, and no contact soldering is required.

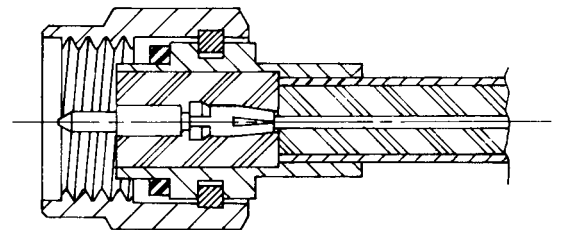

Solder-clamp: This attachment is most useful for right angle plugs and bulkhead jacks. After the connector is assembled to the cable jacket, it can be repositioned relative to the cable by loosening the clamp nut. Electrical performance is similar to direct-solder plugs with contacts.

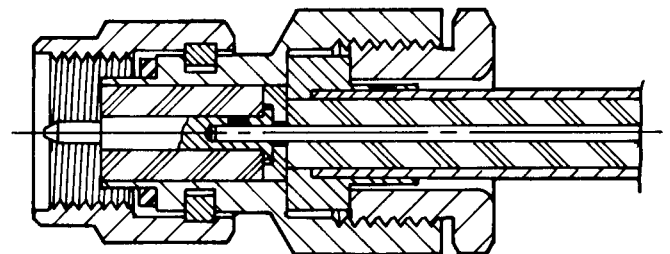

SMA Cable Attachment Methods

Flexible Cable

Crimp (non-captive contact): This attachment method provides the best possible electrical performance, and the fastest assembly. **Solder type** connectors for flexible cable have the same construction, but add a hole in the side of the crimp sleeve for soldering the cable braid to the connector. We do **not** recommend the use of solder type connectors with flexible cable—the heat from soldering may damage the cable dielectric.

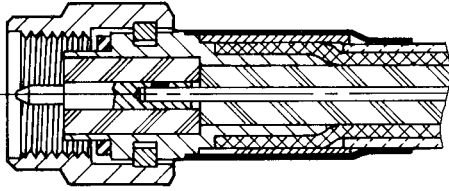

VSWR P/N 9001-1023-001 (200' RG-223 used as load)

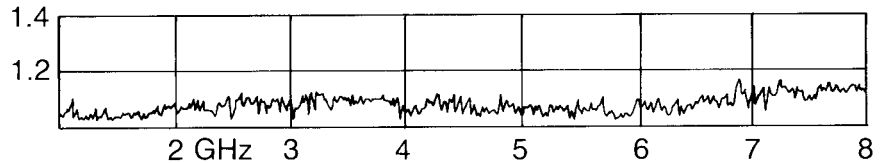

Crimp (captive contact): This attachment method mechanically captivates the center contact to eliminate movement during cable flexure or thermal stress.

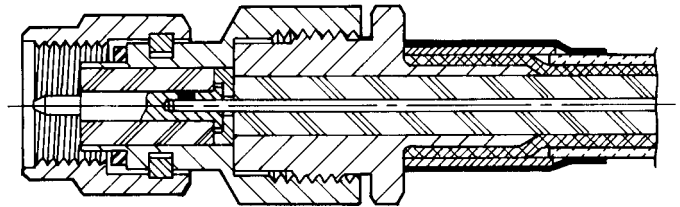

Clamp (captive contact): These connectors can be assembled without special tooling, and are field replaceable.

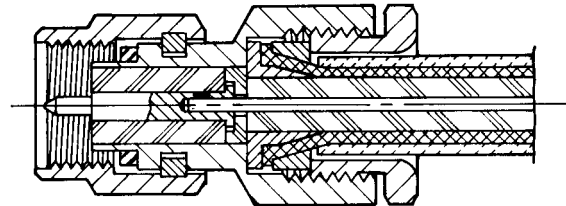

SMA Captivation

All AEP SMA receptacles and adapters use our unique mechanical captivation for contacts and insulators. This method provides retention strength to meet MIL-PRF-39012 requirements, and eliminates RF leakage from epoxy fill holes. The contact barbs and body staking are designed and located to provide electrical performance that equals or exceeds epoxy-captivated types.

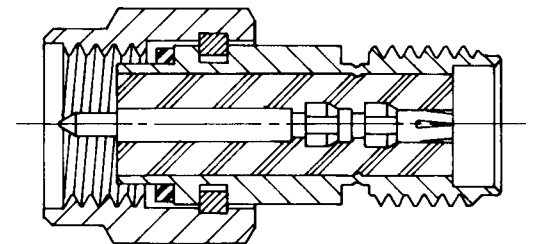

VSWR P/N 5916-1103-603 terminated with 9301-1063-009 on 200' .141 semi-rigid.

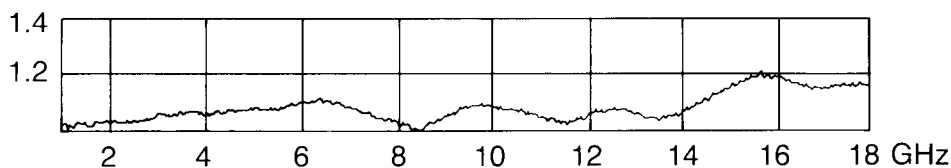

APPLIED ENGINEERING PRODUCTS

(203) 776-2813 • FAX (203) 776-8294

www.aepconnectors.com • aepsales@aepconnectors.com

SMA Cable Plugs for Semi-Rigid Cable

Click on part number to go directly to cable assembly instructions

Straight Plugs

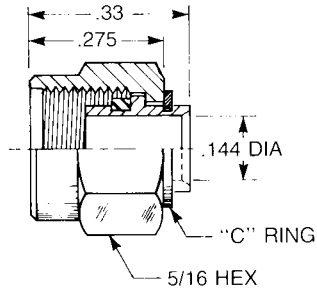

- Direct solder attachment
- Retractable coupling nut
- Cable center conductor used as contact

For .141" semi-rigid:

9301-1063-009 (Gold plated)

9301-7063-009 (Nickel plated)

QPL version available (M39012/92)

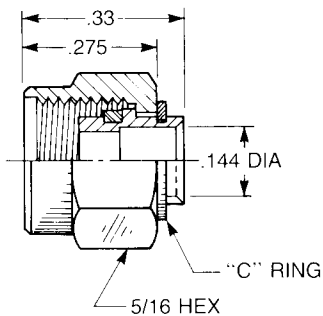

- Direct solder attachment
- Retractable coupling nut
- Cable center conductor used as contact
- Stepped body for use in applications requiring frequent mating and unmating

For .141" semi rigid:

9301-1063-109 (Gold plated)

9301-7063-109 (Nickel plated)

- Direct solder attachment
- Provided with contact and insulator
- Noncaptive contact

For .085" semi-rigid (A = .089):

9401-1083-010 (Gold plated)

9401-7083-010 (Nickel plated)

For .141" semi-rigid (A = .144):

9401-1083-109 (Gold plated)

9401-7083-109 (Nickel plated)

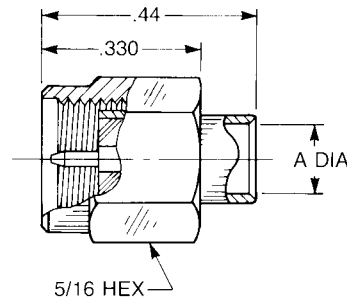

- Direct solder attachment
- Provided with contact and insulator
- Captive contact for one-step cable assembly

For .085" semi-rigid (A = .089):

9401-1583-010 (Gold plated)

9401-7583-010 (Nickel plated)

For .141" semi-rigid (A = .144):

9401-1583-109 (Gold plated)

9401-7583-109 (Nickel plated)

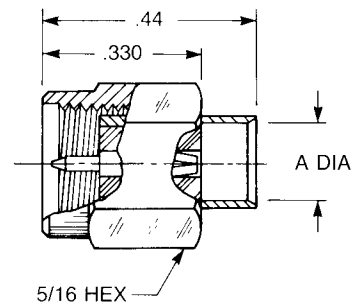

Continued on next page



APPLIED ENGINEERING PRODUCTS

(203) 776-2813 • FAX (203) 776-8294

www.aepconnectors.com • aepsales@aepconnectors.com

SMA Cable Plugs for Semi-Rigid Cable

Click on part number to go directly to cable assembly instructions

Straight Plugs

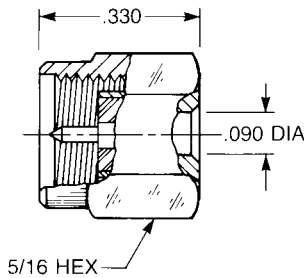

- Direct solder attachment
- Provided with contact and insulator
- Noncaptive contact
- Short body length allows very tight cable bend in dense packaging applications

For .085" semi-rigid:

9401-1083-210 (Gold plated)

9401-7083-210 (Nickel plated)

- Solder-clamp attachment
- Captive contact

For .085" semi-rigid:

9501-1593-010 (Gold plated)

9501-9593-010 (Passivated)

For .141" semi-rigid:

9501-1593-009 (Gold plated)

9501-9593-009 (Passivated)

QPL version available (M39012/79)

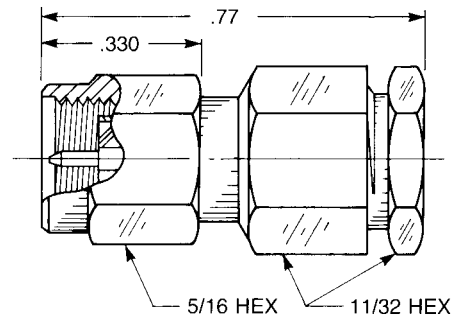

Right Angle Plugs

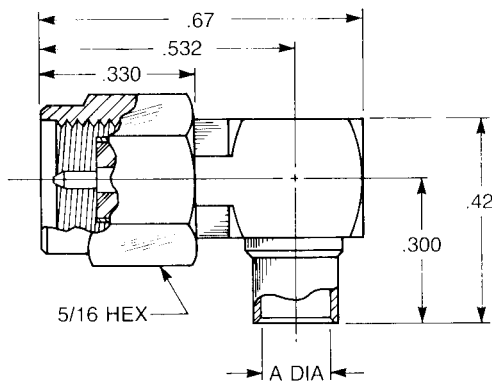

- Direct solder attachment

For .085" semi-rigid (A = .089):

9443-1563-010 (Gold plated)

9443-7563-010 (Nickel plated)

For .141" semi-rigid (A = .144):

9443-1563-009 (Gold plated)

9443-7563-009 (Nickel plated)

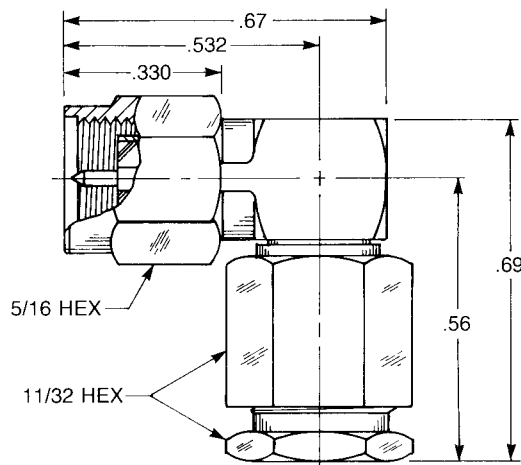

- Solder-clamp attachment

For .085" semi-rigid:

9543-1593-010 (Gold plated)

9543-9593-010 (Passivated)

For .141" semi-rigid:

9543-1593-009 (Gold plated)

9543-9593-009 (Passivated)

SMA Cable Plugs for Flexible Cable

Click on part number to go directly to cable assembly instructions

Straight Plugs

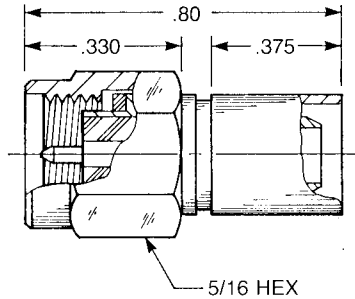

Straight Plug

- Noncaptive contact

Crimp type:

9001-1023-0XX (Gold plated)

9001-9023-0XX (Passivated)

Solder type:

9001-1033-0XX (Gold plated)

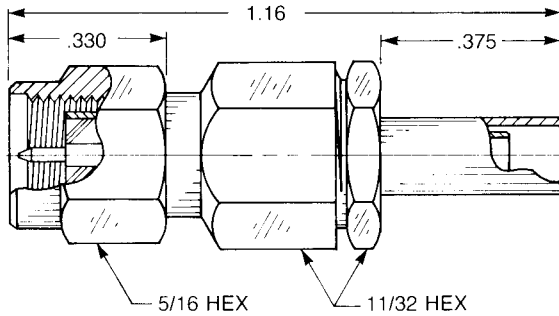

Straight Plug

- Captive contact

Crimp type:

9101-1573-0XX (Gold plated)

9101-9573-0XX (Passivated)

QPL version available (M39012/55)

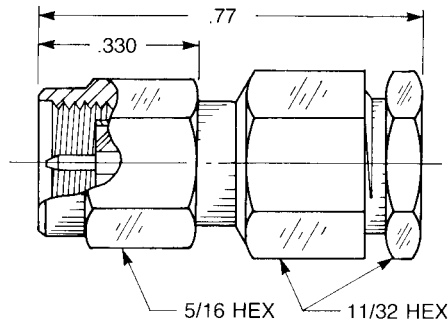

Straight Plug

- Captive contact

Clamp type:

9201-1553-0XX (Gold plated)

9201-9553-0XX (Passivated)

QPL version available (M39012/55)

Substitute the appropriate cable group number for "XX" when ordering:

GROUP	CABLE TYPES	GROUP	CABLE TYPES	GROUP	CABLE TYPES
01	RG142, RG223, M17/60, M17/84, M17/158	04	RG180, RG195, M17/95	06	RG58, RG141, RG303, M17/111, M17/155
02	RG178, RG196, M17/93, M17/169	05	RG178DS, RG196DS	19	RG174DS, RG316DS, M17/151, M17/152, Times RD-316
03	RG174, RG179, RG316, M17/113, M17/119, M17/172, M17/189				



APPLIED ENGINEERING PRODUCTS

(203) 776-2813 • FAX (203) 776-8294

www.aepconnectors.com • aepsales@aepconnectors.com

SMA Cable Plugs for Flexible Cable

Click on part number to go directly to cable assembly instructions

Right Angle Plugs

Right Angle Plug

- Captive contact

Crimp type:

9043-1523-0XX (Gold plated)

9043-9523-0XX (Passivated)

Solder type:

9043-1533-0XX (Gold plated)

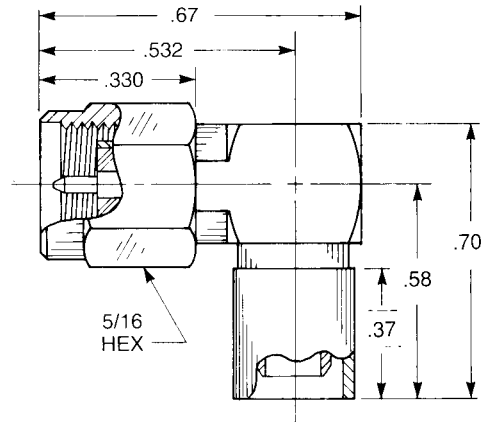

Right Angle Plug

- Captive contact

Clamp type:

9243-1553-0XX (Gold plated)

9243-9553-0XX (Passivated)

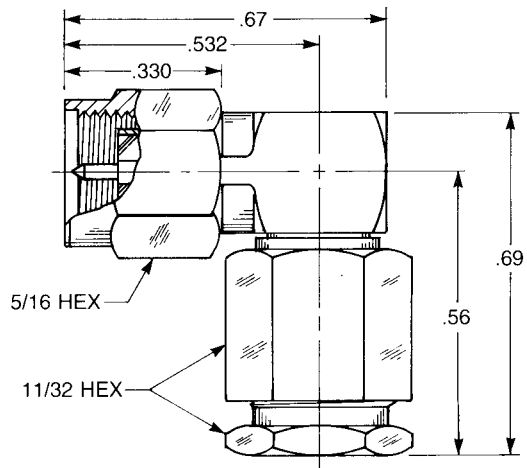

Substitute the appropriate cable group number for "XX" when ordering:

GROUP	CABLE TYPES	GROUP	CABLE TYPES	GROUP	CABLE TYPES
01	RG142, RG223, M17/60, M17/84, M17/158	04	RG180, RG195, M17/95	06	RG58, RG141, RG303, M17/111, M17/155
02	RG178, RG196, M17/93, M17/169	05	RG178DS, RG196DS	19	RG174DS, RG316DS, M17/151, M17/152, Times RD-316
03	RG174, RG179, RG316, M17/113, M17/119, M17/172, M17/189				



APPLIED ENGINEERING PRODUCTS

(203) 776-2813 • FAX (203) 776-8294

www.aepconnectors.com • aepsales@aepconnectors.com

SMA Cable Jacks for Semi-Rigid Cable

Click on part number to go directly to cable assembly instructions

Straight Jacks

Straight Jack

- Direct solder attachment
- Noncaptive contact

For .085" semi-rigid (A = .089):

9402-1083-010 (Gold plated)

9402-7083-010 (Nickel plated)

For .141" semi rigid (A = .144):

9402-1083-009 (Gold plated)

9402-7083-009 (Nickel plated)

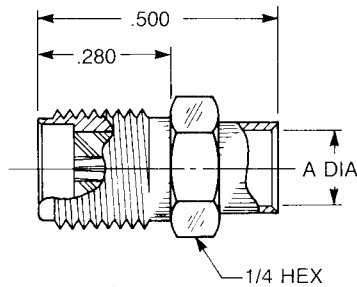

Straight Jack

- Direct solder attachment
- Captive contact for one-step cable assembly

For .085" semi-rigid (A = .089):

9402-1583-010 (Gold plated)

9402-7583-010 (Nickel plated)

For .141" semi-rigid (A = .144):

9402-1583-009 (Gold plated)

9402-7583-009 (Nickel plated)

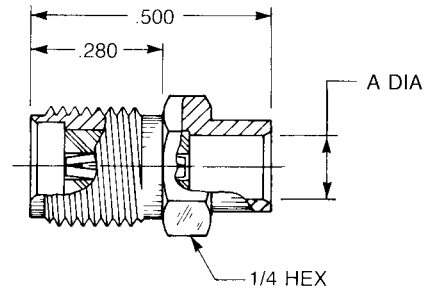

Straight Jack

- Solder-clamp attachment
- Captive contact

For .085" semi-rigid:

9502-1593-010 (Gold plated)

9502-9593-010 (Passivated)

For .141" semi-rigid:

9502-1593-009 (Gold plated)

9502-9593-009 (Passivated)

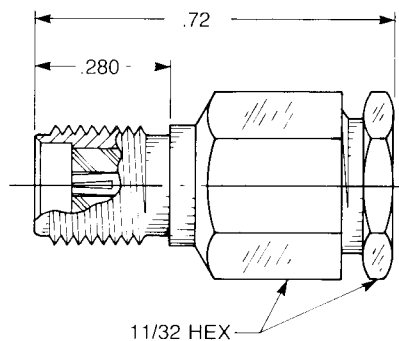

SMA Cable Jacks for Flexible Cable

Click on part number to go directly to cable assembly instructions

Straight Jacks

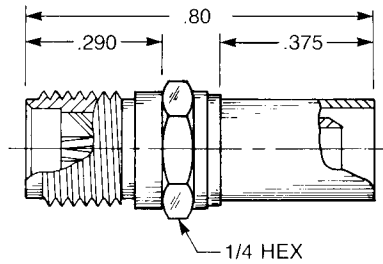

Straight Jack

- Noncaptive contact

Crimp type:

9002-1023-0XX (Gold plated)

9002-9023-0XX (Passivated)

Solder type:

9002-1033-0XX (Gold plated)

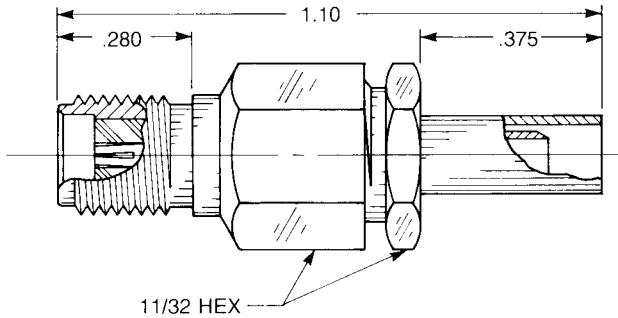

Straight Jack

- Captive contact

Crimp type:

9102-1573-0XX (Gold plated)

9102-9573-0XX (Passivated)

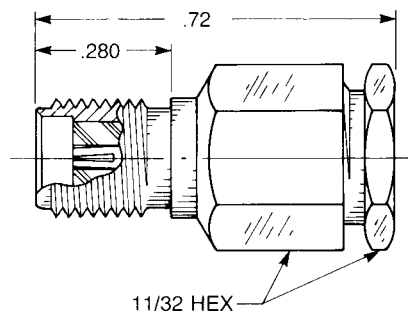

Straight Jack

- Captive contact

Clamp type:

9202-1553-0XX (Gold plated)

9202-9553-0XX (Passivated)

Substitute the appropriate cable group number for "XX" when ordering:

GROUP	CABLE TYPES	GROUP	CABLE TYPES	GROUP	CABLE TYPES
01	RG142, RG223, M17/60, M17/84, M17/158	04	RG180, RG195, M17/95	06	RG58, RG141, RG303, M17/111, M17/155
02	RG178, RG196, M17/93, M17/169	05	RG178DS, RG196DS	19	RG174DS, RG316DS, M17/151, M17/152, Times RD-316
03	RG174, RG179, RG316, M17/113, M17/119, M17/172, M17/189				

SMA Bulkhead Jacks for Semi-Rigid Cable

Click on part number to go directly to cable assembly instructions

Straight Jacks

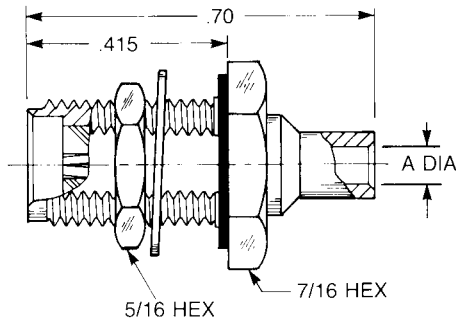

- Direct solder attachment
- With mounting gasket
- Noncaptive contact

For .085" semi-rigid (A = .089)

9453-1083-010 (Gold plated)

9453-7083-010 (Nickel plated)

For .141" semi-rigid (A = .144):

9453-1083-009 (Gold plated)

9453-7083-009 (Nickel plated)

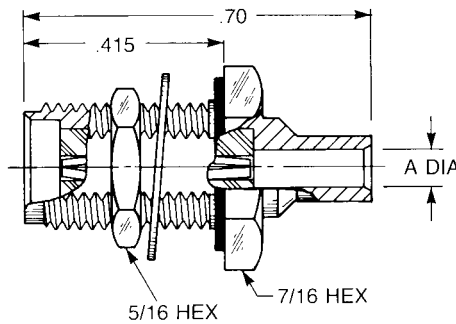

- Direct solder attachment
- With mounting gasket
- Captive contact for one-step cable assembly

For .085" semi-rigid (A = .089):

9453-1583-010 (Gold plated)

9453-7583-010 (Nickel plated)

For .141" semi-rigid (A = .144):

9453-1583-009 (Gold plated)

9453-7583-009 (Nickel plated)

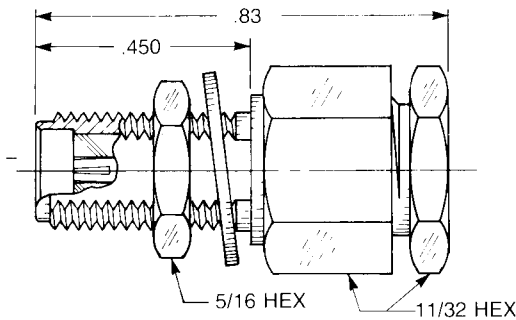

- Solder-clamp attachment
- Captive contact

For .085" semi-rigid:

9530-1593-010 (Gold plated)

9530-9593-010 (Passivated)

For .141" semi-rigid:

9530-1593-009 (Gold plated)

9530-9593-009 (Passivated)

QPL version available (M39012/83)

Right Angle Jack

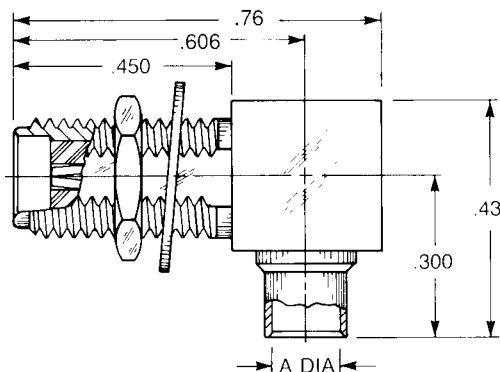

- Direct solder attachment

For .085" semi-rigid (A = .089):

9613-1563-010 (Gold plated)

9613-7563-010 (Nickel plated)

For .141" semi-rigid (A = .144):

9613-1563-009 (Gold plated)

9613-7563-009 (Nickel plated)



APPLIED ENGINEERING PRODUCTS

(203) 776-2813 • FAX (203) 776-8294

www.aepconnectors.com • aepsales@aepconnectors.com

SMA Bulkhead Jacks for Flexible Cable

Click on part number to go directly to cable assembly instructions

Straight Jacks

Straight Bulkhead Jack

- Noncaptive contact

Crimp type:

9030-1023-0XX (Gold plated)

9030-9023-0XX (Passivated)

Solder type:

9030-1033-0XX (Gold plated)

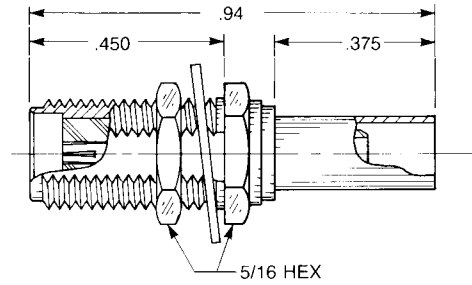

Straight Bulkhead Jack

- Captive contact

Crimp type:

9130-1573-0XX (Gold plated)

9130-9573-0XX (Passivated)

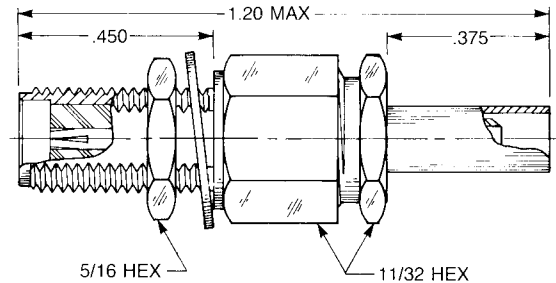

Straight Bulkhead Jack

- Captive contact

Clamp type:

9230-1553-0XX (Gold plated)

9230-9553-0XX (Passivated)

QPL version available (M39012/59)

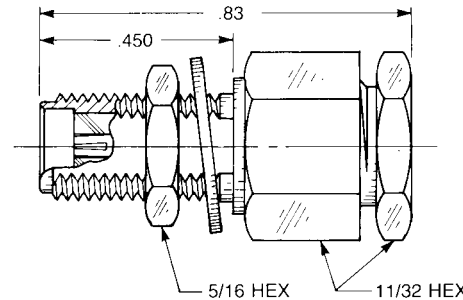

Right Angle Jack

Right Angle Bulkhead Jack

Crimp type:

9613-1523-0XX (Gold plated)

9613-9523-0XX (Passivated)

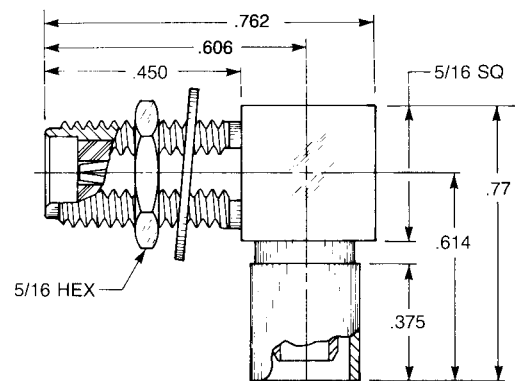

Substitute the appropriate cable group number for "XX" when ordering:

GROUP	CABLE TYPES	GROUP	CABLE TYPES	GROUP	CABLE TYPES
01	RG142, RG223, M17/60, M17/84, M17/158	04	RG180, RG195, M17/95	06	RG58, RG141, RG303, M17/111, M17/155
02	RG178, RG196, M17/93, M17/169	05	RG178DS, RG196DS	19	RG174DS, RG316DS, M17/151, M17/152, Times RD-316
03	RG174, RG179, RG316, M17/113, M17/119, M17/172, M17/189				



APPLIED ENGINEERING PRODUCTS

(203) 776-2813 • FAX (203) 776-8294

www.aepconnectors.com • aepsales@aepconnectors.com

SMA Panel Jacks for Semi-Rigid Cable

Click on part number to go directly to cable assembly instructions

Straight Jacks

- Direct solder attachment
- Square flange
- Noncaptive contact

For .085" semi-rigid (A = .089):

9431-1083-010 (Gold plated)

9431-7083-010 (Nickel plated)

For .141" semi-rigid (A = .144):

9431-1083-009 (Gold plated)

9431-7083-009 (Nickel plated)

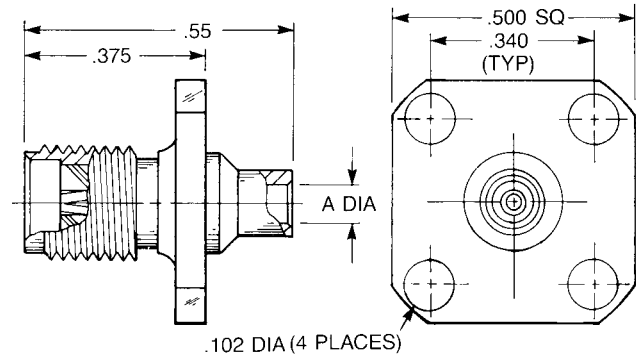

- Direct solder attachment
- Square flange
- Captive contact for one-step cable assembly

For .085" semi-rigid (A = .089):

9431-1583-010 (Gold plated)

9431-7583-010 (Nickel plated)

For .141" semi-rigid (A = .144):

9431-1583-009 (Gold plated)

9431-7583-009 (Nickel plated)

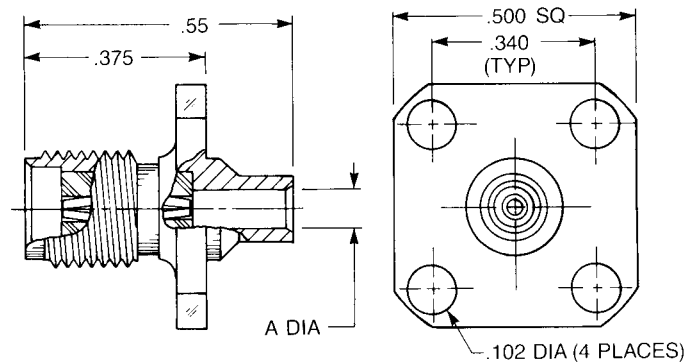

- Direct solder attachment
- 2-hole flange
- Noncaptive contact

For .085" semi-rigid (A = .089):

9441-1083-010 (Gold plated)

9441-7083-010 (Nickel plated)

For .141" semi-rigid (A = .144):

9441-1083-009 (Gold plated)

9441-7083-009 (Nickel plated)

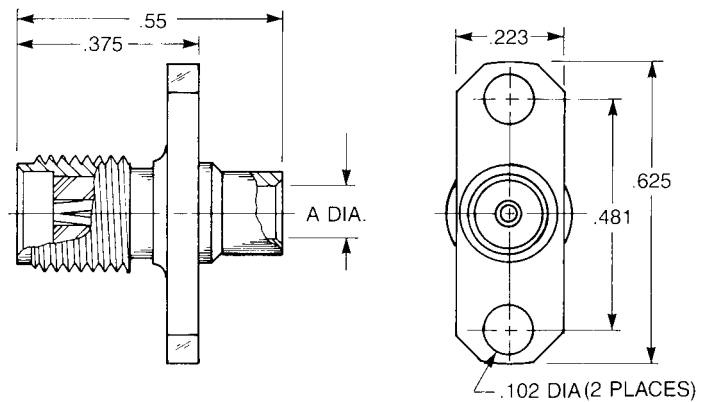

- Direct solder attachment
- 2-hole flange
- Captive contact for one-step cable assembly

For .085" semi-rigid (A = .089):

9441-1583-010 (Gold plated)

9441-7583-010 (Nickel plated)

For .141" semi-rigid (A = .144):

9441-1583-009 (Gold plated)

9441-7583-009 (Nickel plated)

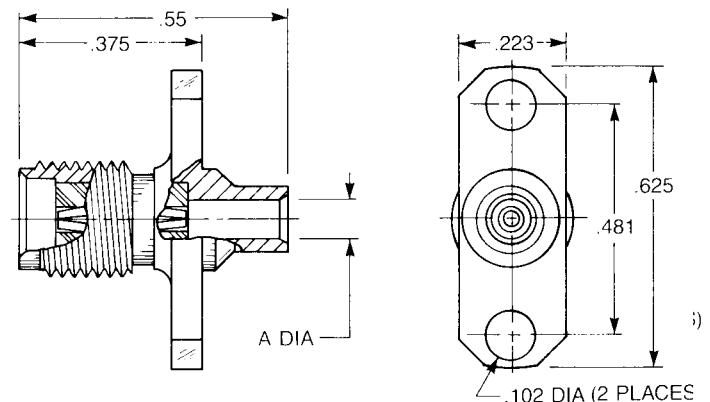

SMA Panel Jacks for Flexible Cable

Click on part number to go directly to cable assembly instructions

Straight Jacks

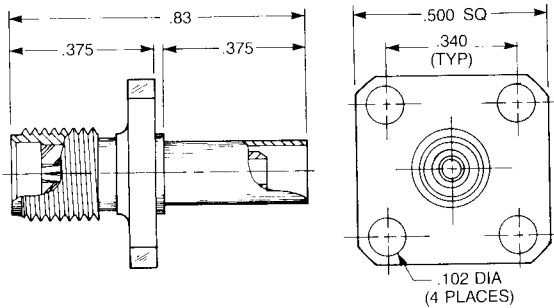

Straight Panel Jack

- Noncaptive contact
- Square flange

Crimp type:

9031-1023-0XX (Gold plated)

9031-9023-0XX (Passivated)

Solder type:

9031-1033-0XX (Gold plated)

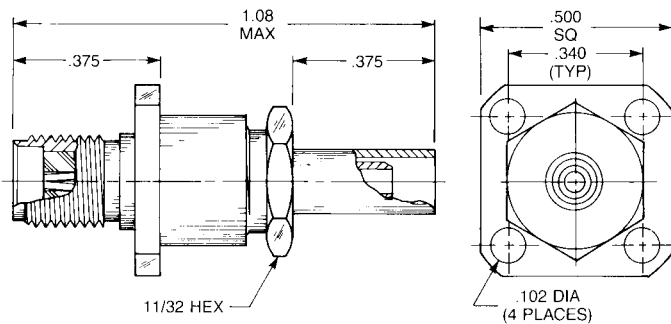

Straight Panel Jack

- Captive contact
- Square flange

Crimp type:

9131-1573-0XX (Gold plated)

9131-9573-0XX (Passivated)

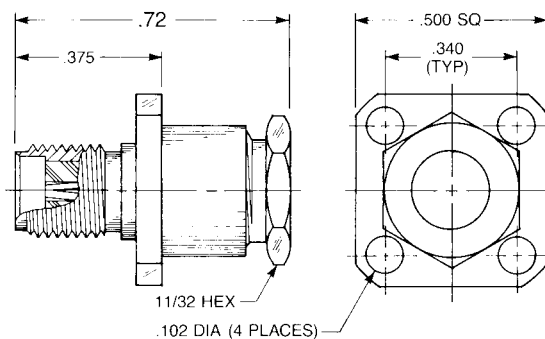

Straight Panel Jack

- Captive contact
- Square flange

Clamp type:

9231-1553-0XX (Gold plated)

9231-9553-0XX (Passivated)

Substitute the appropriate cable group number for "XX" when ordering:

GROUP	CABLE TYPES	GROUP	CABLE TYPES	GROUP	CABLE TYPES
01	RG142, RG223, M17/60, M17/84, M17/158	04	RG180, RG195, M17/95	06	RG58, RG141, RG303, M17/111, M17/155
02	RG178, RG196, M17/93, M17/169	05	RG178DS, RG196DS	19	RG174DS, RG316DS, M17/151, M17/152, Times RD-316
03	RG174, RG179, RG316, M17/113, M17/119, M17/172, M17/189				



APPLIED ENGINEERING PRODUCTS

(203) 776-2813 • FAX (203) 776-8294

www.aepconnectors.com • aepsales@aepconnectors.com

SMA Straight Panel Jack Receptacles

Extended Contact and Insulator

- Extended contact and insulator
- 1/2" square flange

Captive contact:

9004-1113-000 (Gold plated)

9004-9113-000 (Passivated)

Noncaptive contact:

9004-1213-000 (Gold plated)

9004-9213-000 (Passivated)

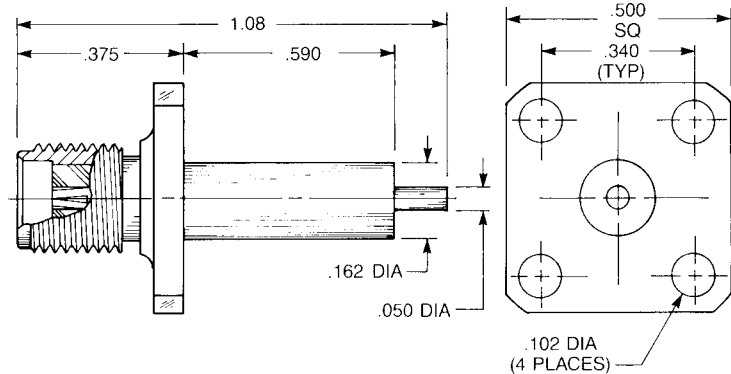

- Extended contact and insulator
- 2-hole flange

Captive contact:

9008-1113-000 (Gold plated)

9008-9113-000 (Passivated)

Noncaptive contact:

9008-1213-000 (Gold plated)

9008-9213-000 (Passivated)

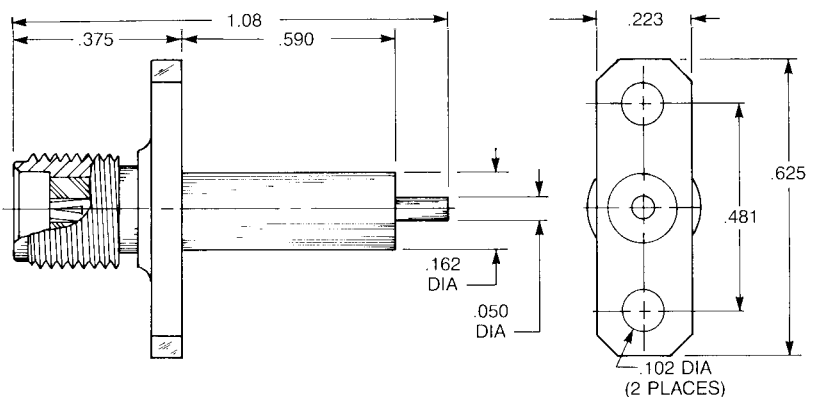

- Extended contact and insulator
- 3/8" square flange

Captive contact:

9076-1113-000 (Gold plated)

9076-9113-000 (Passivated)

Noncaptive contact:

9076-1213-000 (Gold plated)

9076-9213-000 (Passivated)

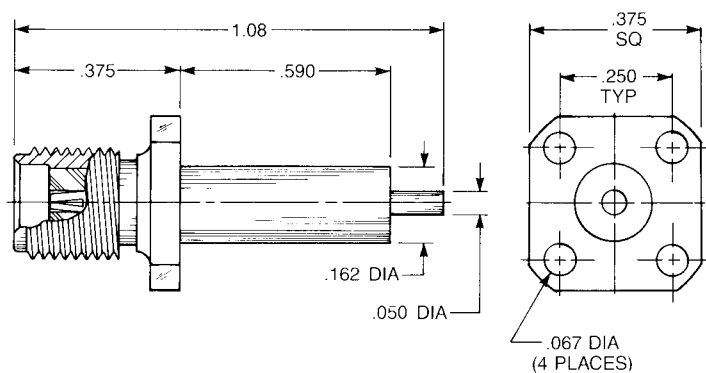

- Extended contact and insulator
- Rectangular flange

Captive contact:

9007-1113-000 (Gold plated)

9007-9113-000 (Passivated)

Noncaptive contact:

9007-1213-000 (Gold plated)

9007-9213-000 (Passivated)

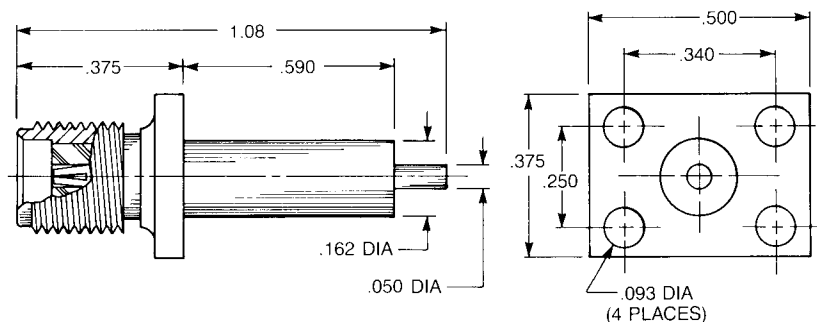

SMA Straight Panel Jack Receptacles

Solder Pot Contact

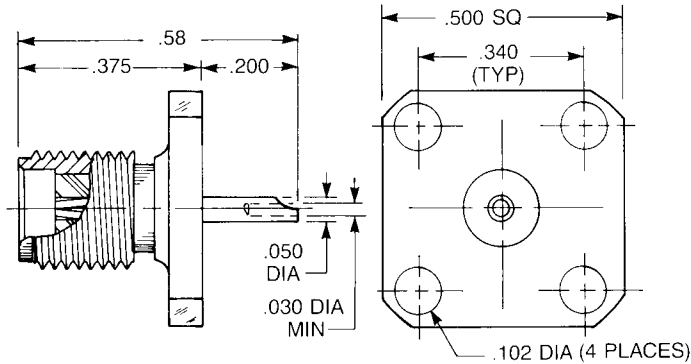

Straight Panel Jack Receptacle

- Solder pot contact
- 1/2" square flange

Captive contact:

9404-1113-000 (Gold plated)

9404-9113-000 (Passivated)

QPL version available (M39012/60)

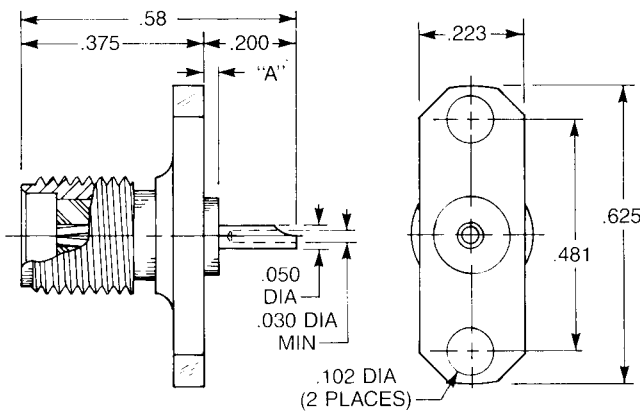

Straight Panel Jack Receptacle

- Solder pot contact
- 2-hole flange

Captive contact (A = .030):

9408-1113-000 (Gold plated)

9408-9113-000 (Passivated)

Captive contact (A = .000):

9408-1113-002 (Gold plated)

9408-9113-002 (Passivated)

QPL version available (M39012/60)

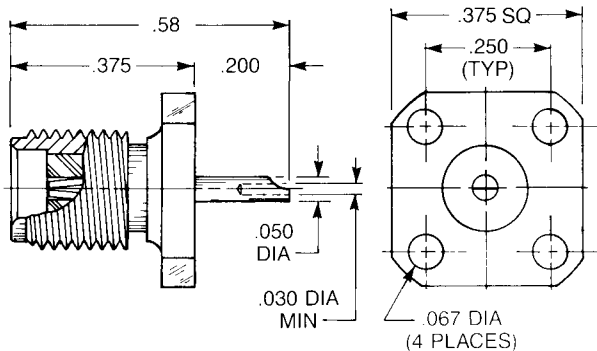

Straight Panel Jack Receptacle

- Solder pot contact
- 3/8" square flange

Captive contact:

9476-1113-000 (Gold plated)

9476-9113-000 (Passivated)

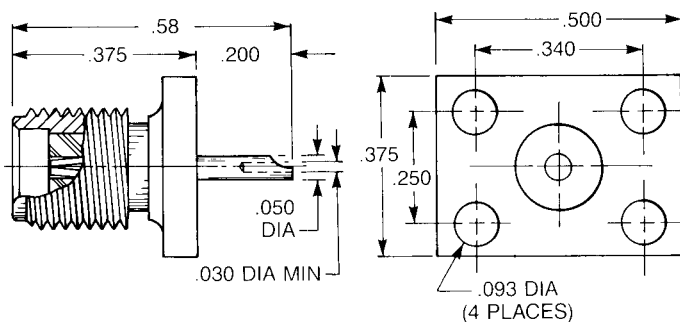

Straight Panel Jack Receptacle

- Solder pot contact
- Rectangular flange

Captive contact:

9407-1113-000 (Gold plated)

9407-9113-000 (Passivated)



SMA Straight Panel Jack Receptacles

Tab Contact

Straight Panel Jack Receptacle

- Tab contact
- 1/2" square flange

Captive contact:

9104-1113-000 (Gold plated)

9104-9113-000 (Passivated)

Noncaptive contact:

9104-1213-000 (Gold plated)

9104-9213-000 (Passivated)

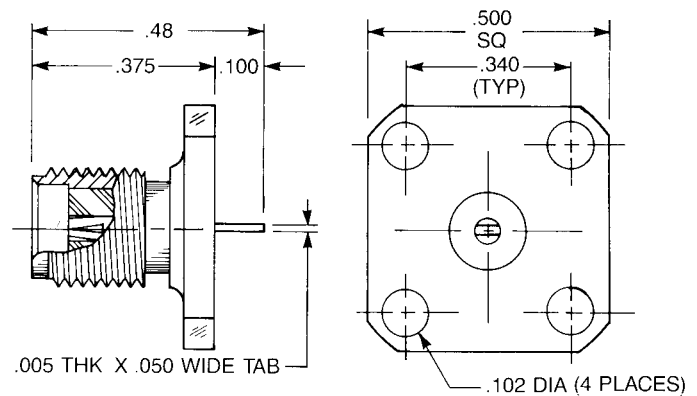

Straight Panel Jack Receptacle

- Tab contact
- 2-hole flange

Captive contact:

9108-1113-000 (Gold plated)

9108-9113-000 (Passivated)

Noncaptive contact:

9108-1213-000 (Gold plated)

9108-9213-000 (Passivated)

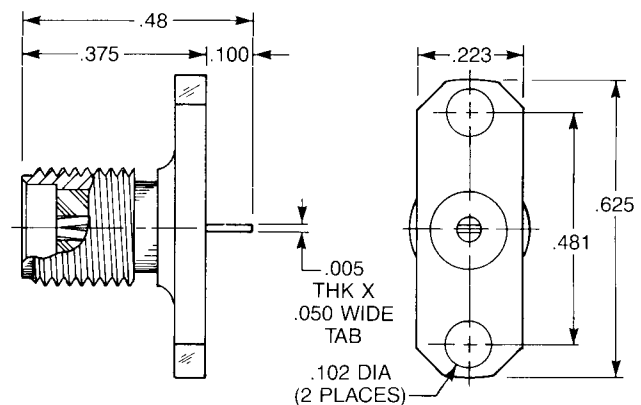

Straight Panel Jack Receptacle

- Tab contact
- 3/8" square flange

Captive contact:

9176-1113-000 (Gold plated)

9176-9113-000 (Passivated)

Noncaptive contact:

9176-1213-000 (Gold plated)

9176-9213-000 (Passivated)

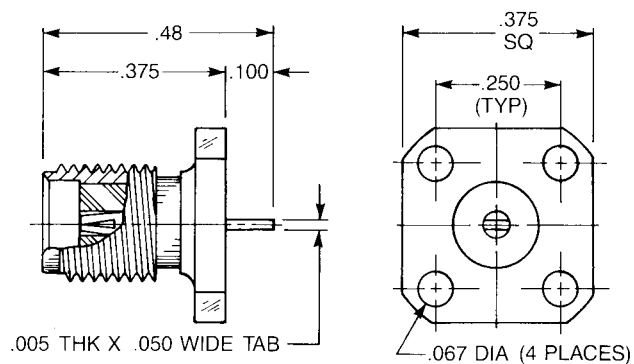

Straight Panel Jack Receptacle

- Tab contact
- Rectangular flange

Captive contact:

9107-1113-000 (Gold plated)

9107-9113-000 (Passivated)

Noncaptive contact:

9107-1213-000 (Gold plated)

9107-9213-000 (Passivated)

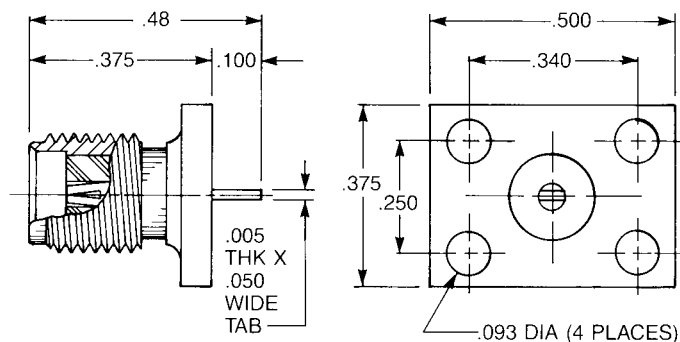

SMA Straight Panel Jack Receptacles

Slotted Contact

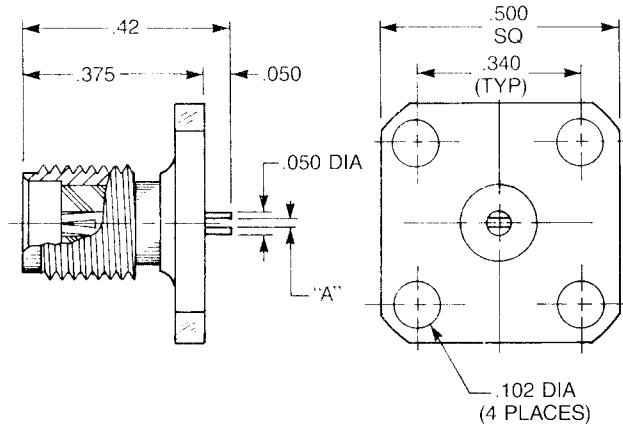

Straight Panel Jack Receptacle

- Slotted contact
- 1/2" square flange

Dim. A	Captive contact:	
.012	9204-1113-002	(Gold plated)
	9204-9113-002	(Passivated)
.018	9204-1113-001	(Gold plated)
	9204-9113-001	(Passivated)
.025	9204-1113-003	(Gold plated)
	9204-9113-003	(Passivated)
	Noncaptive contact:	
.012	9204-1213-002	(Gold plated)
	9204-9213-002	(Passivated)
.018	9204-1213-001	(Gold plated)
	9204-9213-001	(Passivated)
.025	9204-1213-003	(Gold plated)
	9204-9213-003	(Passivated)

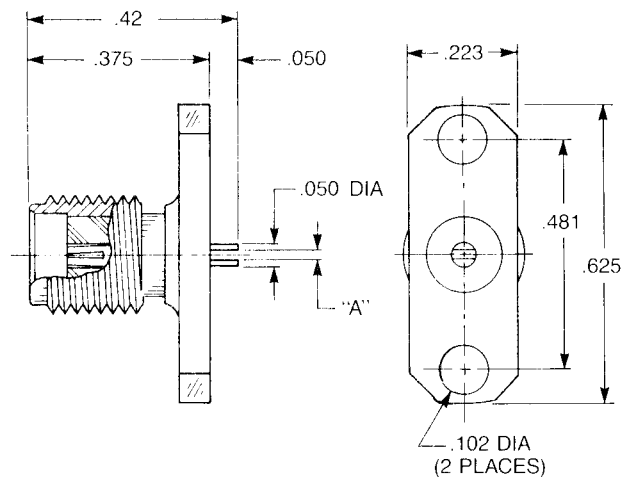

Straight Panel Jack Receptacle

- Slotted contact
- 2-hole flange

Dim. A	Captive contact:	
.012	9208-1113-000	(Gold plated)
	9208-9113-000	(Passivated)
.018	9208-1113-001	(Gold plated)
	9208-9113-001	(Passivated)
.025	9208-1113-002	(Gold plated)
	9208-9113-002	(Passivated)
	Noncaptive contact:	
.012	9208-1213-000	(Gold plated)
	9208-9213-000	(Passivated)
.018	9208-1213-001	(Gold plated)
	9208-9213-001	(Passivated)
.025	9208-1213-002	(Gold plated)
	9208-9213-002	(Passivated)

SMA Right Angle Panel Jack Receptacles

Solder Pot Contact

Right Angle Panel Jack Receptacle

- Solder pot contact
- 1/2" square flange

9424-1513-000 (Gold plated)

9424-9513-000 (Passivated)

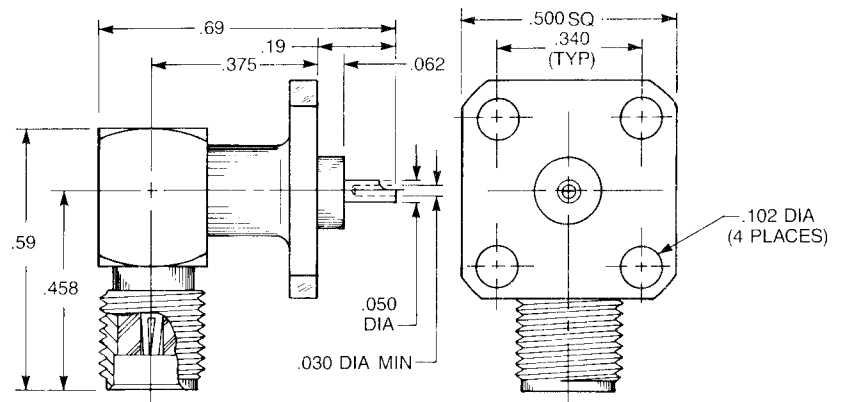

Low Profile Right Angle Panel Jack Receptacle

- Solder pot contact
- 1/2" square flange

9425-1513-000 (Gold plated)

9425-9513-000 (Passivated)

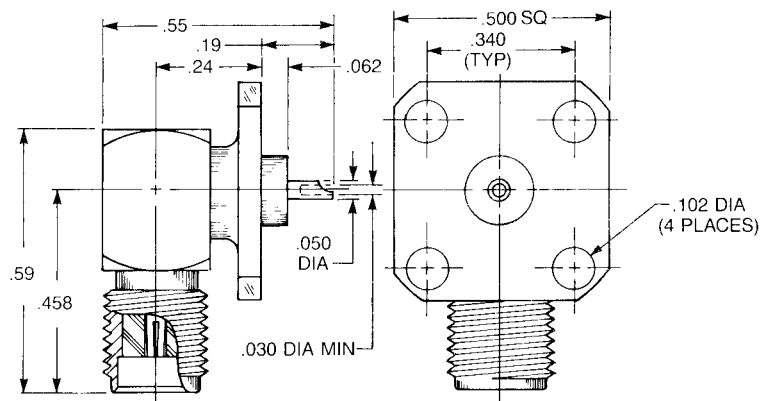

Tab Contact

Right Angle Panel Jack Receptacle

- Tab contact
- 1/2" hole flange

9124-1513-000 (Gold plated)

9124-9513-000 (Passivated)

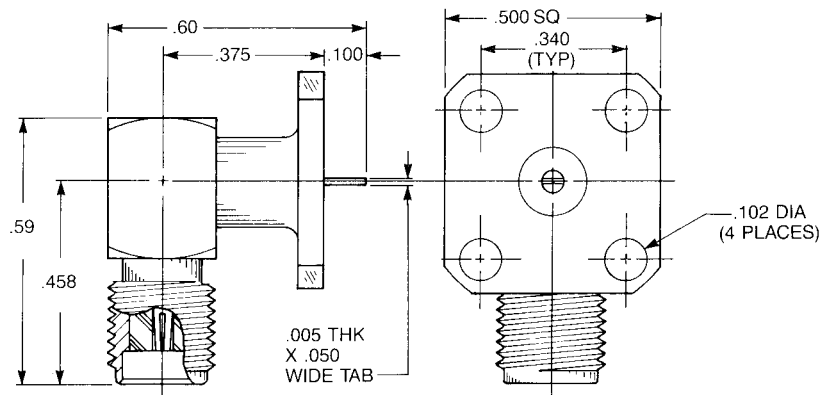

Right Angle Panel Jack Receptacle

- Tab contact
- 2-hole flange

9126-1513-000 (Gold plated)

9126-9513-000 (Passivated)

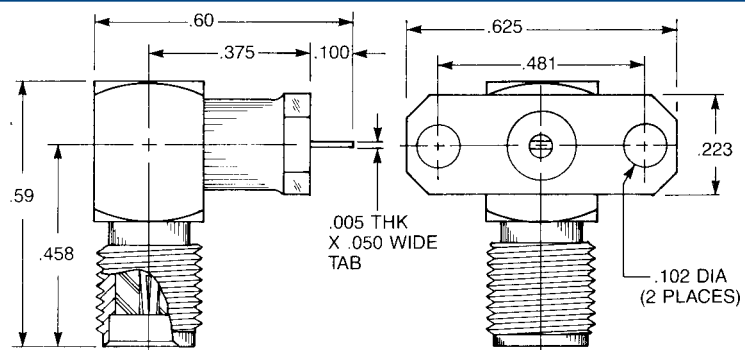

SMA Receptacles for .025" Microstrip

Standard SMA receptacles with tab contacts have the tab milled from a .050" diameter round contact. This .050" diameter is flush with the rear insulator of the connector. When these connectors are used with .025" thick microstrip, a capacitive coupling can be introduced because of the close proximity of the microstrip ground plane to the outer diameter of the contact.

These receptacles eliminate the coupling by reducing the contact rear diameter to .025". The insulator diameter at the rear of the connector is reduced to .083" to maintain 50Ω impedance.

Tab Contact

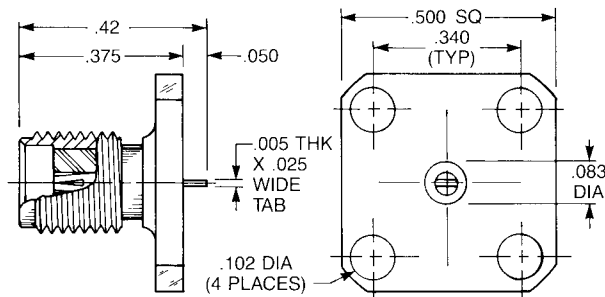

Straight Jack Receptacle

- 1/2" square flange

Captive contact:

9114-1113-000 (Gold plated)

9114-9113-000 (Passivated)

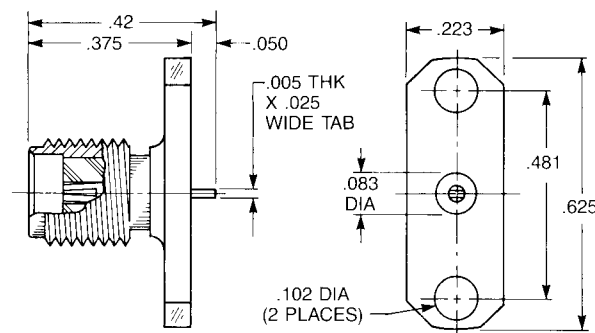

Straight Jack Receptacle

- 2-hole flange

Captive contact:

9118-1113-000 (Gold plated)

9118-9113-000 (Passivated)

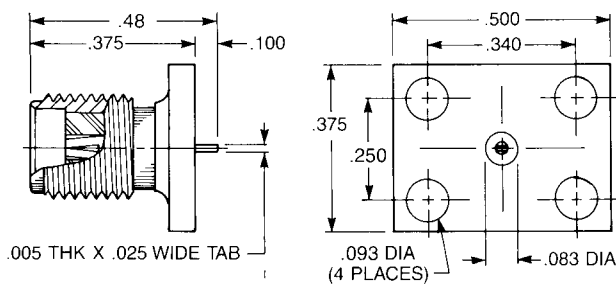

Straight Jack Receptacle

- Rectangular flange

Captive contact:

9117-1113-000 (Gold plated)

9117-9113-000 (Passivated)

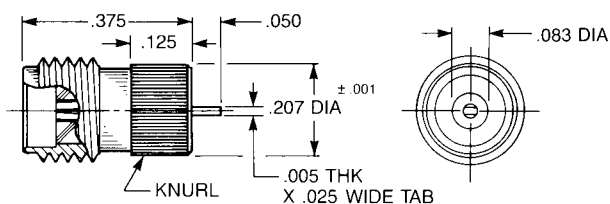

Straight Jack Receptacle

- Knurl mount

Captive contact:

9163-1113-000 (Gold plated)

9163-9113-000 (Passivated)



SMA Receptacles for .010" Microstrip

These connectors have .010" diameter contact extensions for good electrical transition to narrow microstrip lines. The reduced-diameter insulators are extended beyond the flange to maintain 50Ω impedance through the microstrip package wall. All have captive contacts.

Round Contact

Straight Jack Receptacle

- 1/2" square flange

A = .057:

9304-1113-014 (Gold plated)

9304-9113-014 (Passivated)

A = .125

9304-1113-013 (Gold plated)

9304-9113-013 (Passivated)

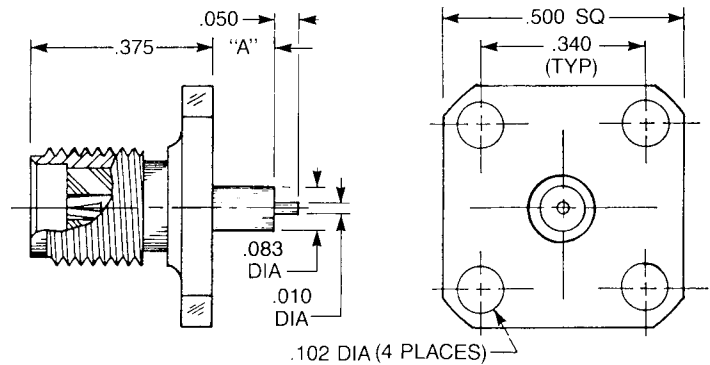

Straight Jack Receptacle

- 2-hole flange

A = .057:

9308-1113-003 (Gold plated)

9308-9113-003 (Passivated)

A = .125:

9308-1113-001 (Gold plated)

9308-9113-001 (Passivated)

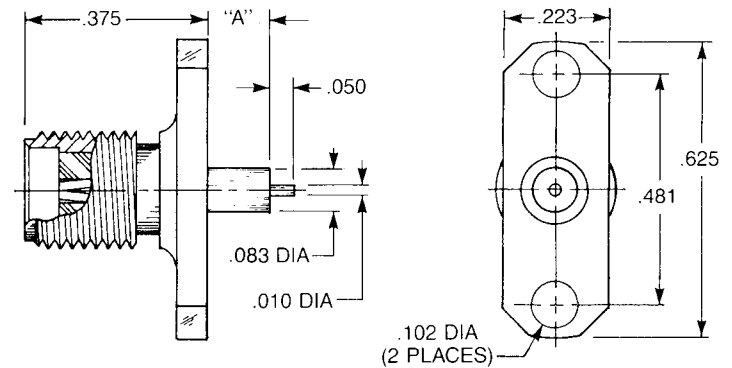

Straight Jack Receptacle

- 3/8" square flange

A = .057:

9376-1113-002 (Gold plated)

9376-9113-002 (Passivated)

A = .125:

9376-1113-001 (Gold plated)

9376-9113-001 (Passivated)

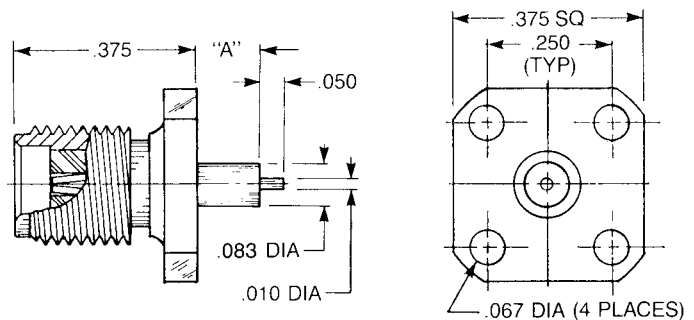

Straight Jack Receptacle

- Rectangular flange

A = .057:

9307-1113-002 (Gold plated)

9307-9113-002 (Passivated)

A = .125:

9307-1113-001 (Gold plated)

9307-9113-001 (Passivated)

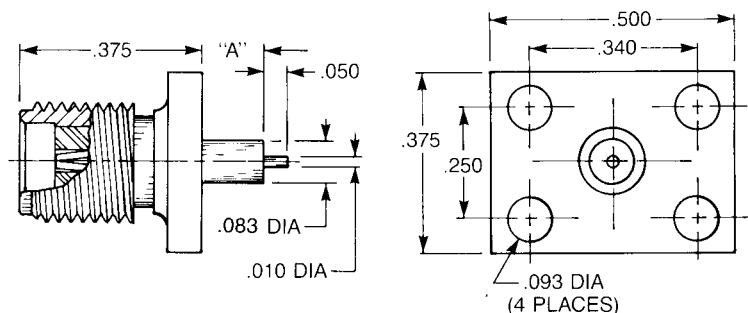

SMA Panel Plug Receptacles

Straight—Extended Contact and Insulator

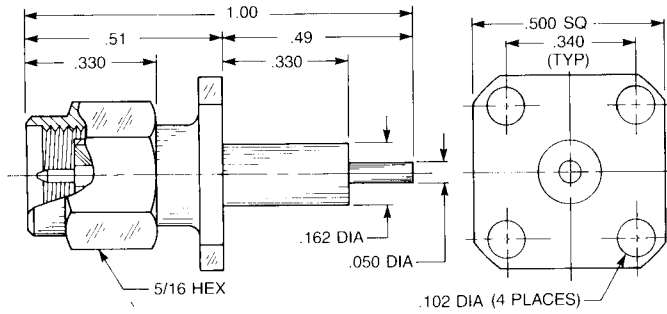

Straight Panel Plug Receptacle

- Extended contact and insulator
- 1/2" square flange

Captive contact:

9009-1113-000 (Gold plated)

9009-9113-000 (Passivated)

Noncaptive contact:

9009-1213-000 (Gold plated)

9009-9213-000 (Passivated)

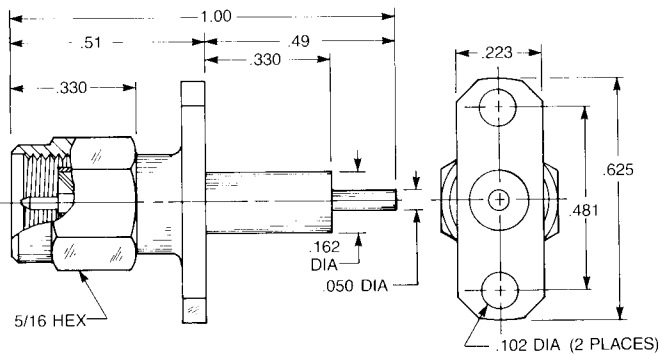

Straight Panel Plug Receptacle

- Extended contact and insulator
- 2-hole flange

Captive contact:

9055-1113-000 (Gold plated)

9055-9113-000 (Passivated)

Noncaptive contact:

9055-1213-000 (Gold plated)

9055-9213-000 (Passivated)



SMA Panel Plug Receptacles

Straight—Solder Pot Contact

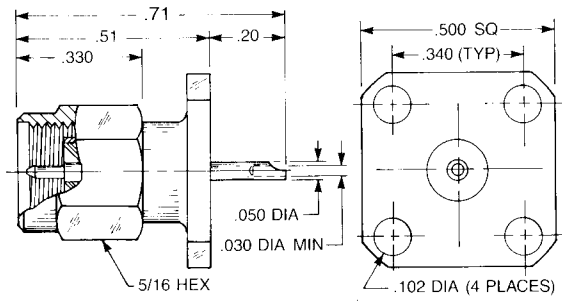

Straight Panel Plug Receptacle

- Solder pot contact
- 1/2" square flange

Captive contact:

9409-1113-000 (Gold plated)

9409-9113-000 (Passivated)

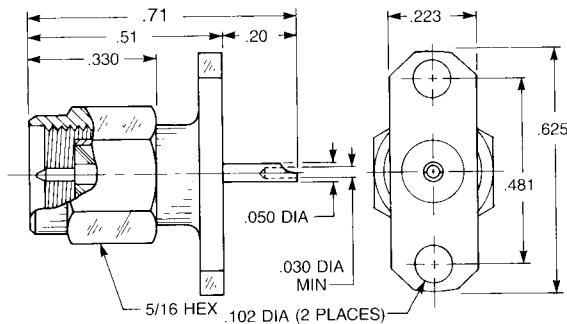

Straight Panel Plug Receptacle

- Solder pot contact
- 2-hole flange

Captive contact:

9455-1113-000 (Gold plated)

9455-9113-000 (Passivated)

Right Angle—Solder Pot Contact

Right Angle Panel Plug Receptacle

- Solder pot contact
- 1/2" square flange

9454-1513-000 (Gold plated)

9454-9513-000 (Passivated)

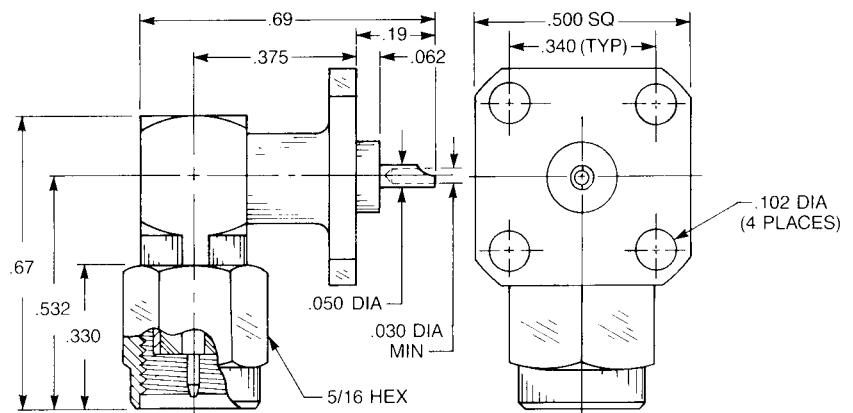

SMA Panel Plug Receptacles

Straight—Tab Contact

Straight Panel Plug Receptacle

- Tab contact
- 1/2" square flange

Captive contact:

9109-1113-000 (Gold plated)

9109-9113-000 (Passivated)

Noncaptive contact:

9109-1213-000 (Gold plated)

9109-9213-000 (Passivated)

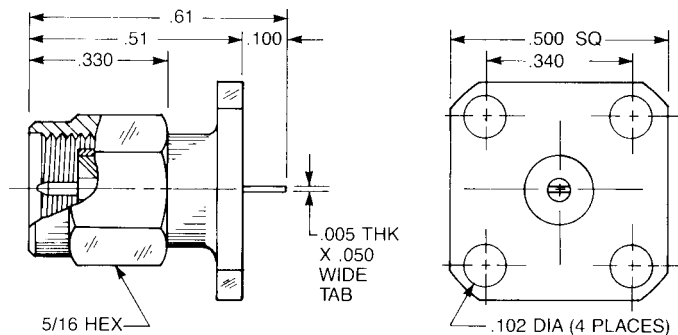

Straight Panel Plug Receptacle

- Tab contact
- 2-hole flange

Captive contact:

9155-1113-000 (Gold plated)

9155-9113-000 (Passivated)

Noncaptive contact:

9155-1213-000 (Gold plated)

9155-9213-000 (Passivated)

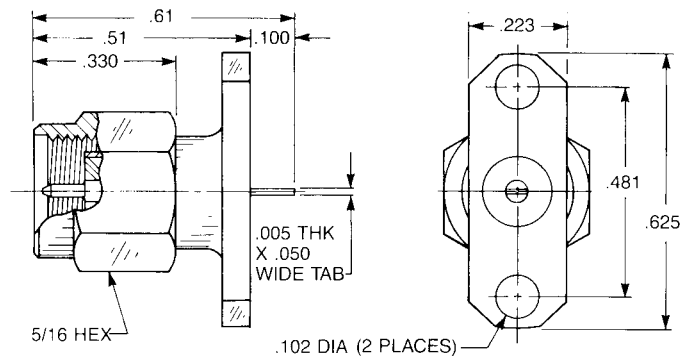

Right Angle—Tab Contact

Right Angle Panel Plug Receptacle

- Tab contact
- 1/2" square flange

9154-1513-000 (Gold plated)

9154-9513-000 (Passivated)

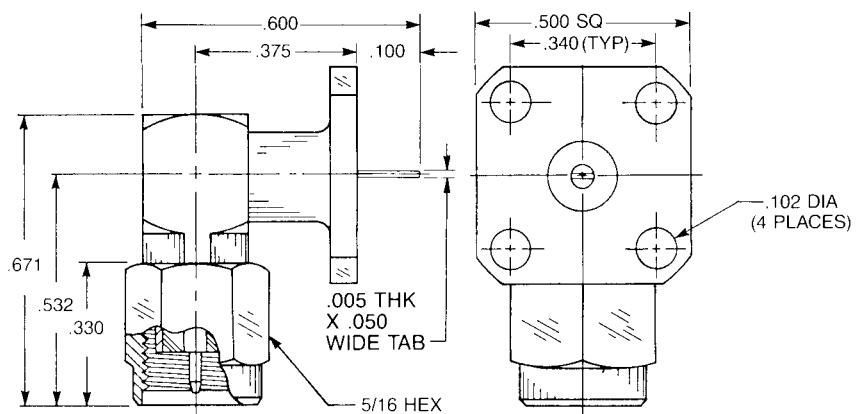

SMA Bulkhead Jack Receptacles

Straight—Solder Pot Contact

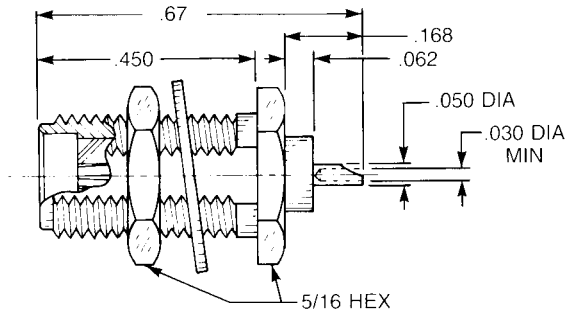

Straight Bulkhead Jack Receptacle

- Solder pot contact
- Rear mount

Captive contact:

9412-1113-000 (Gold plated)

9412-9113-000 (Passivated)

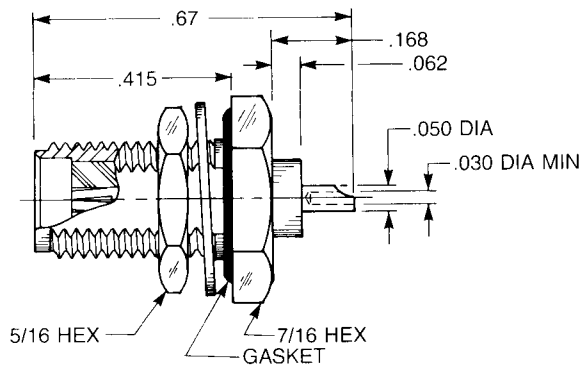

Straight Bulkhead Jack Receptacle

- Solder pot contact
- Rear mount
- With mounting gasket

Captive contact:

9432-1113-000 (Gold plated)

9432-9113-000 (Passivated)

QPL version available (M39012/61)

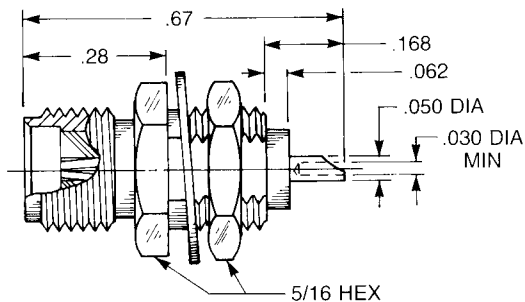

Straight Bulkhead Jack Receptacle

- Solder pot contact
- Front mount

Captive contact:

9422-1113-000 (Gold plated)

9422-9113-000 (Passivated)

QPL version available (M39012/61)

Right Angle—Solder Pot Contact

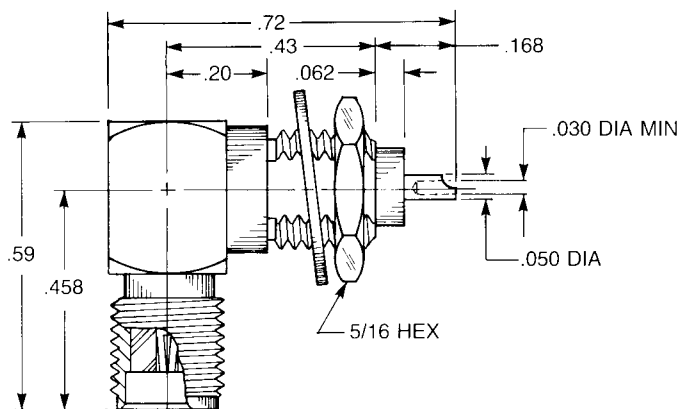

Right Angle Bulkhead Jack Receptacle

- Solder pot contact
- Front mount

Captive contact:

9609-1513-000 (Gold plated)

9609-9513-000 (Passivated)



SMA Bulkhead Jack Receptacles

Straight—Extended Contact and Insulator

Straight Bulkhead Jack Receptacle

- Post contact
 - Round body
 - Provided with two mounting nuts and one lockwasher
- Captive contact:
9013-1113-000 (Gold plated)
9013-9113-000 (Passivated)

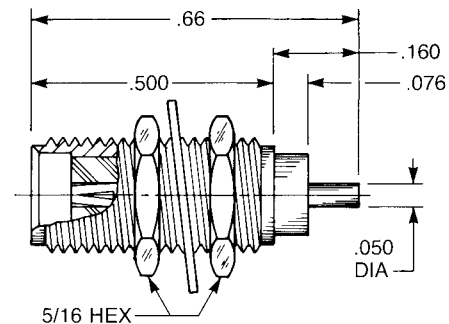

Straight Bulkhead Jack Receptacle

- Post contact
 - D-flatted body
 - Provided with two mounting nuts and one lockwasher
- Captive contact:
9056-1113-000 (Gold plated)
9056-9113-000 (Passivated)

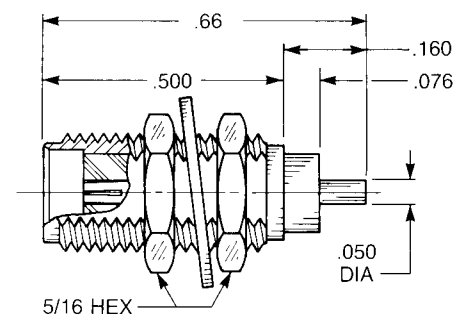

Straight—Solder Pot Contact

Straight Bulkhead Jack Receptacle

- Solder pot contact
 - Round body
 - Provided with two mounting nuts and one lockwasher
- Captive contact:
9413-1113-000 (Gold plated)
9413-9113-000 (Passivated)

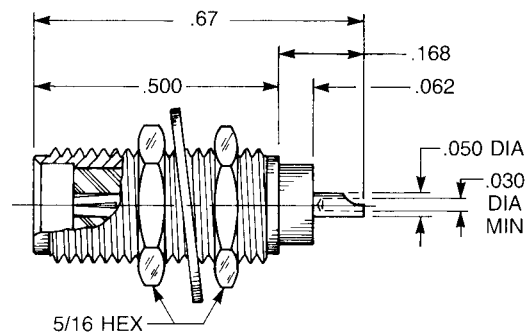

Straight Bulkhead Jack Receptacle

- Solder pot contact
 - D-flatted body
 - Provided with two mounting nuts and one lockwasher
- Captive contact:
9456-1113-002 (Gold plated)
9456-9113-002 (Passivated)

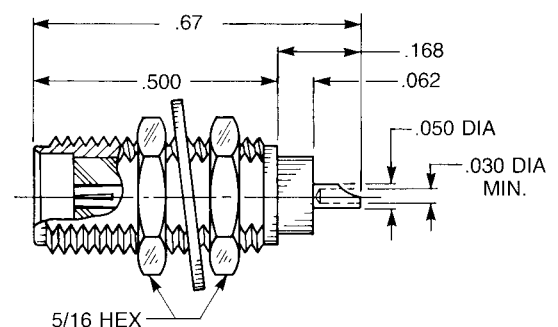

SMA Knurl Mount Receptacles

These knurl mount receptacles can provide an economical alternative to flange mounted connectors, and are especially useful in dense packaging applications.

They should be used in panels at least .100" thick.

Straight Jack—Extended Contact and Insulator

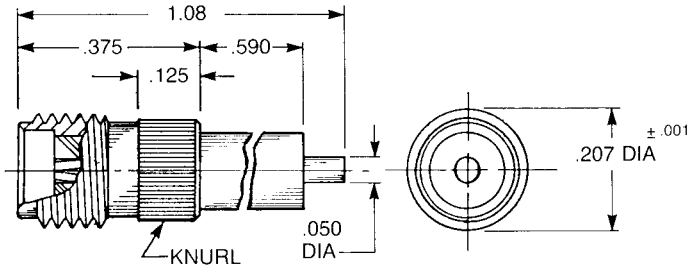

- Extended contact and insulator
- Captive contact:
9033-1113-000 (Gold plated)
9033-9113-000 (Passivated)
- Noncaptive contact:
9033-1213-000 (Gold plated)
9033-9213-000 (Passivated)

Straight Jack—Solder Pot Contact

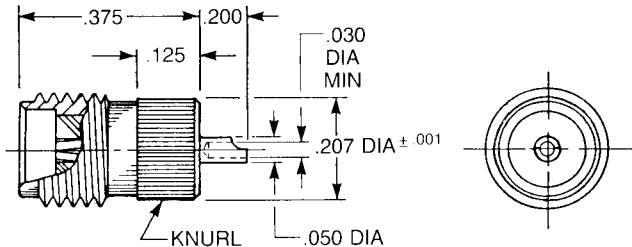

- Solder pot contact
- Captive contact:
9433-1113-000 (Gold plated)
9433-9113-000 (Passivated)

Straight Jack—Tab Contact

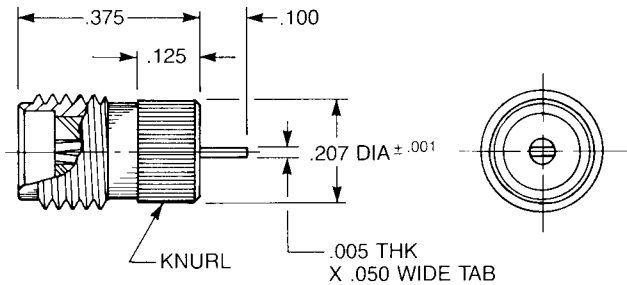

- Tab contact
- Captive contact:
9133-1113-000 (Gold plated)
9133-9113-000 (Passivated)
- Noncaptive contact:
9133-1213-000 (Gold plated)
9133-9213-000 (Passivated)

Straight Plug—Tab Contact

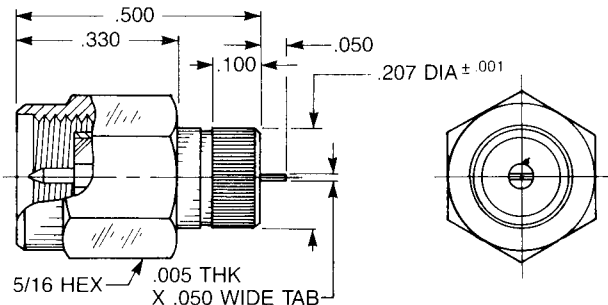

- Tab contact
- Captive contact:
9139-1113-000 (Gold plated)
9139-9113-000 (Passivated)
- Noncaptive contact:
9139-1213-000 (Gold plated)
9139-9213-000 (Passivated)



SMA P.C. Board Receptacles

Straight Jack

Straight Jack Receptacle

9650-1113-000 (Gold plated)

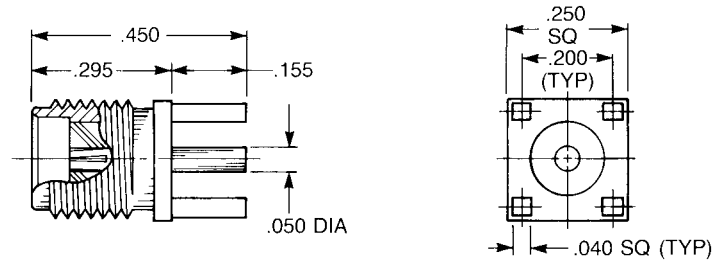

Right Angle Jack

Right Angle Jack Receptacle

9647-1513-000 (Gold plated)

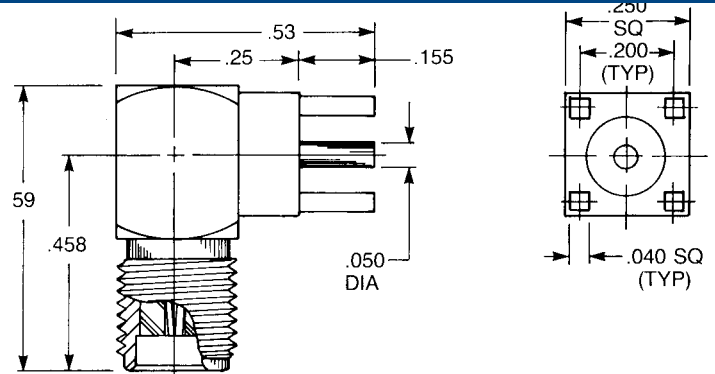

Straight Plug

Straight Plug Receptacle

9649-1113-000 (Gold plated)

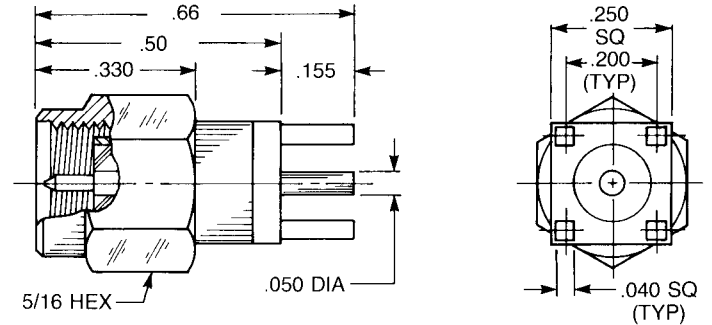

Right Angle Plug

Right Angle Plug Receptacle

9646-1513-000 (Gold plated)

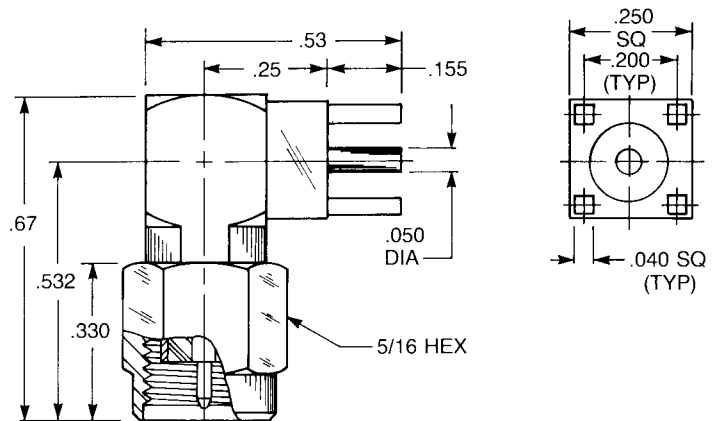

SMA Stripline Receptacles

Straight Jacks

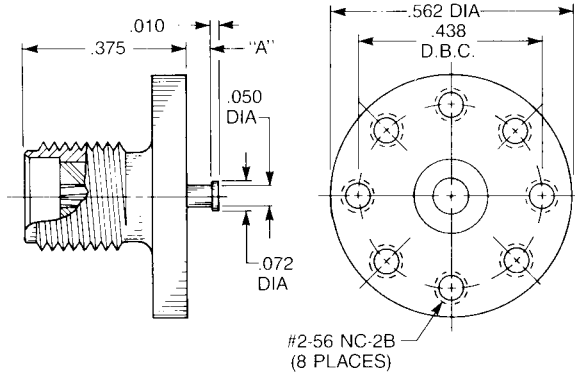

- Standard flange
- Noncaptive contact

Dim. A

.031	9003-1213-001	(Gold plated)
	9003-9213-001	(Passivated)
.063	9003-1213-002	(Gold plated)
	9003-9213-002	(Passivated)
.125	9003-1213-003	(Gold plated)
	9003-9213-003	(Passivated)

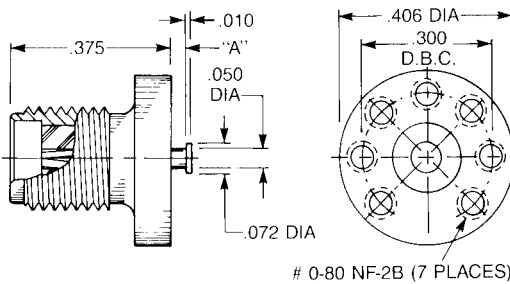

- Small diameter flange
- Noncaptive contact

Dim. A

.031	9610-1213-001	(Gold plated)
	9610-9213-001	(Passivated)
.063	9610-1213-002	(Gold plated)
	9610-9213-002	(Passivated)
.125	9610-1213-003	(Gold plated)
	9610-9213-003	(Passivated)

Right Angle Jack

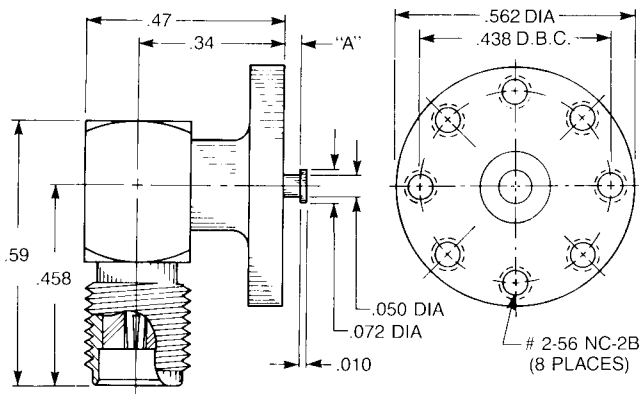

- Standard flange
- Noncaptive rear contact

Dim. A

.031	9035-1513-001	(Gold plated)
	9035-9513-001	(Passivated)
.063	9035-1513-002	(Gold plated)
	9035-9513-002	(Passivated)
.125	9035-1513-003	(Gold plated)
	9035-9513-003	(Passivated)

Straight Plug

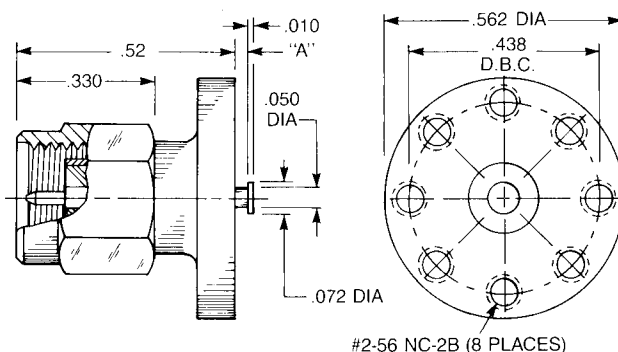

- Standard flange
- Noncaptive contact

Dim. A

.031	9034-1213-001	(Gold plated)
	9034-9213-001	(Passivated)
.063	9034-1213-002	(Gold plated)
	9034-9213-002	(Passivated)
.125	9034-1213-003	(Gold plated)
	9034-9213-003	(Passivated)



SMA Hermetic Seal Launchers

AEP SMA hermetic seal launchers are designed to fit hermetic seals with .012" to .036" pin diameters. Connectors for use with .012—.018" pins feature an internal body structure that compensates electrically for the stepdown in diameter from the connector interface to the seal outer diameter, as shown in the illustration. These units also incorporate a conductive-elastomer EMI gasket to prevent RF leakage at the interface between the connector flange and the MIC package.

Connectors for seals with .020" or .036" pin diameters have straight-through body geometry, and do not use EMI gaskets.

Passivated stainless steel body finish is standard for this series; gold-plated bodies are available as an option.

Connector / seal design—connectors for use with .012—.018" diameter pins

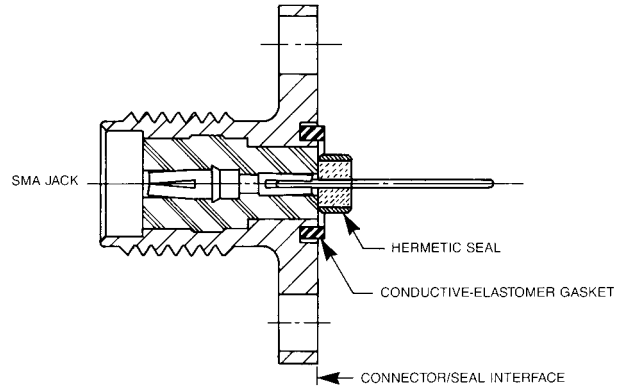

Electrical Performance Data

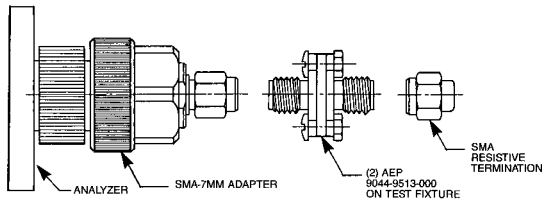

Test setup: Two connectors (P/N 9044-9513-000) mounted back-to-back on fixture incorporating hermetic seal (P/N 920-55). Precision SMA plug termination used as load.

The VSWR plot below is for the connector/fixture combination; data for a single connector can be extrapolated by taking the square root of the reading at a given frequency. Insertion loss readings should be divided by two to obtain performance for a single connector.

Electrical performance in actual use may vary based on the characteristics of the pin-to-line transition.

VSWR

HP 8510

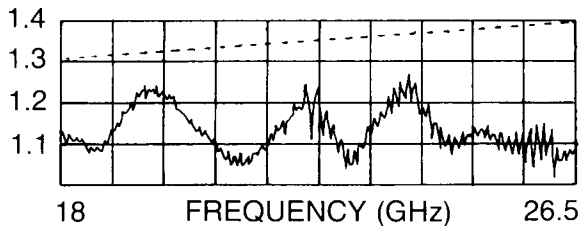

Dotted line = $VSWR (1.05 + .005F [GHz])^2$
 Max. VSWR DC-18 GHz: 1.23: 1 @ 13.93 GHz
 Max. VSWR DC-26.5 GHz: 1.28: 1 @ 23.74 GHz

Insertion loss (dB)

HP 8510

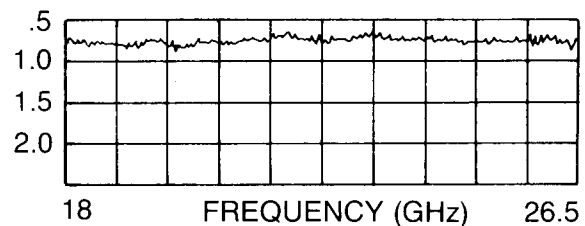

See next page for hermetic seal specifications and mounting dimensions.



APPLIED ENGINEERING PRODUCTS

(203) 776-2813 • FAX (203) 776-8294

www.aepconnectors.com • aepsales@aepconnectors.com

Hermetic Seal Specifications

Materials:

All metal parts: Kovar.

Glass: Corning glass as noted:

P/N	Glass type
920-55	7052
920-56	7070
920-69	7052
920-82	7070
920-92	7052

Finish:

All metal parts: Gold plated per MIL-G-45204 type II, grade C, class 1, over nickel per MIL-C-26074, class 1, over copper per MIL-C-14550.

Hermeticity:

Greater than 1×10^{-8} cc/second @ 1 atmosphere.

Solderability:

Per MIL-Std-202, Method 209.

Meniscus:

.005" max.

Pin concentricity:

.003" T.I.R.

Temperature range:

-65–250° C.

Impedance:

$50 \pm 1\Omega$.

Frequency range:

DC-26 GHz.

Insertion loss:

.1 dB max. to 12.4 GHz;
.2 dB max. to 18 GHz;
.25 dB max. to 26 GHz.

VSWR:

Dependent on application.

Voltage rating:

335 VRMS max. @ sea level.

Current:

500 mA.

Dielectric Withstanding Voltage:

1000 VRMS @ sea level.

Insulation resistance:

100K megohms (@25° C)

Mounting Dimensions

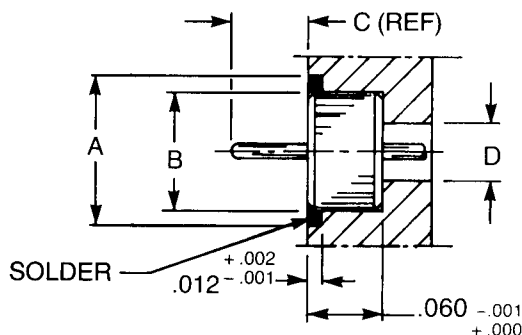

P/N	A ($\pm .001$)	B ($\pm .001$)	C
920-55	.127	.102	.070
920-56	.140	.115	.070
920-69	.188	.163	.060
920-82	.127	.102	.070
920-92	.188	.163	.075

Notes:

- 1) Front of seal and solder should be flush to .005" above mounting surface.
- 2) Diameters ("D") in chart are for 50 Ω impedance; Teflon dielectric diameters are for applications which use a support insulator for the hermetic seal pin (user option).

Pin Diameter	"D" (Air dielectric)	"D" (Teflon dielectric)
.012	.028	.040
.015	.035	.050
.018	.041	.059
.020	.046	.066



SMA Hermetic Seal Launchers

For hermetic seals with .012" diameter pins

Straight Jacks

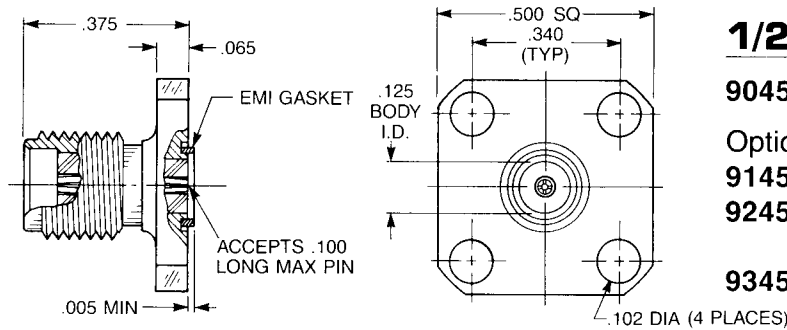

1/2" Square Flange

9045-9513-000

Optional packaging:

9145-9513-000 (Includes 920-55)

9245-9513-000 (Includes 920-55 and 907-111-1)

9345-9513-000 (Includes 907-111-1)

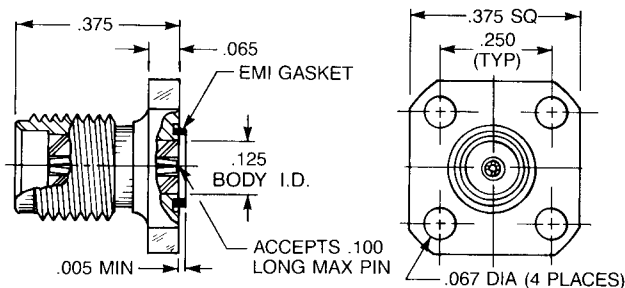

3/8" Square Flange

9079-9513-000

Optional packaging:

9179-9513-000 (Includes 920-55)

9279-9513-000 (Includes 920-55 and 907-111-1)

9379-9513-000 (Includes 907-111-1)

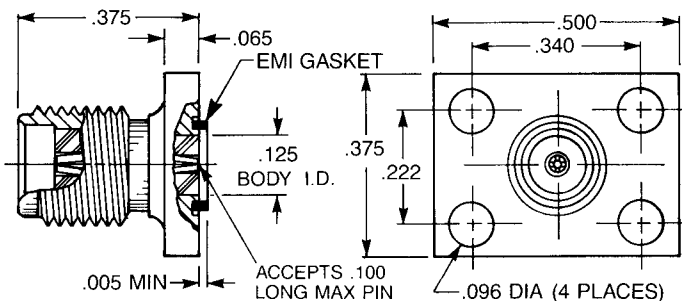

Rectangular Flange

9062-9513-000

Optional packaging:

9162-9513-000 (Includes 920-55)

9262-9513-000 (Includes 920-55 and 907-111-1)

9362-9513-000 (Includes 907-111-1)

These units accept hermetic seal pin diameters .011-.015"

Hermetic Seal and Accessory Contact

Solder-In Hermetic Seal

P/N 920-55

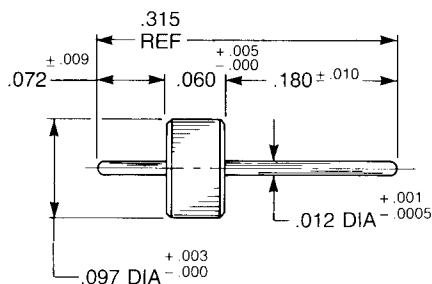

Accessory Contact

P/N 907-111-1

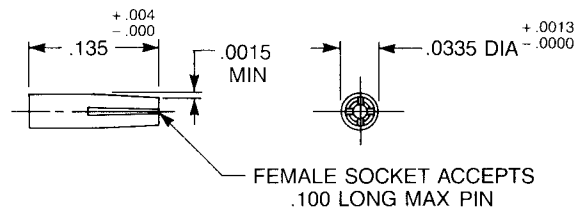

Material: Beryllium copper

Finish: Gold per MIL-G-45204, type II, class I, grade C, over .0001 copper per MIL-C-14550



APPLIED ENGINEERING PRODUCTS

(203) 776-2813 • FAX (203) 776-8294

www.aepconnectors.com • aepsales@aepconnectors.com

SMA Hermetic Seal Launchers

For hermetic seals with .012" diameter pins

Straight Jacks

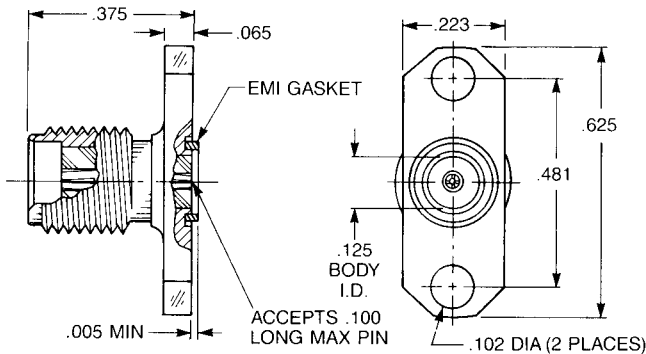

2-Hole Flange

9044-9513-000

Optional packaging:

9144-9513-000 (Includes 920-55)

9244-9513-000 (Includes 920-55 and 907-111-1)

9344-9513-000 (Includes 907-111-1)

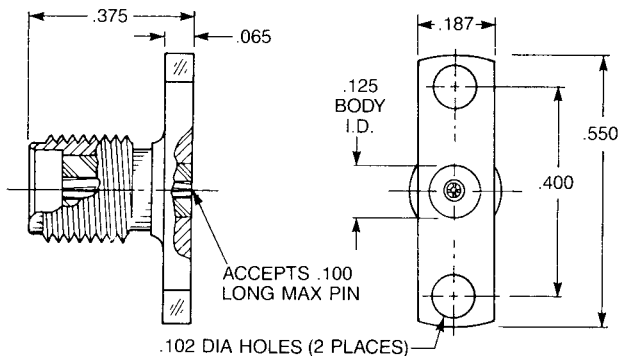

Narrow 2-Hole Flange

No EMI gasket

9080-9513-000

Optional packaging:

9180-9513-000 (Includes 920-55)

9280-9513-000 (Includes 920-55 and 907-111-1)

9380-9513-000 (Includes 907-111-1)

These units accept hermetic seal pin diameters .011-.015"

Hermetic Seal and Accessory Contact

Solder-In Hermetic Seal

P/N 920-55

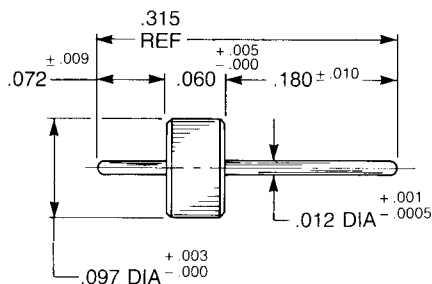

Accessory Contact

P/N 907-111-1

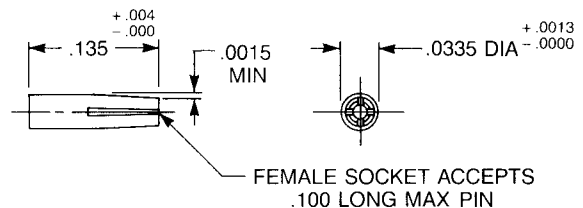

FEMALE SOCKET ACCEPTS
.100 LONG MAX PIN

Material: Beryllium copper

Finish: Gold per MIL-G-45204, type II, class I, grade C, over .0001 copper per MIL-C-14550



APPLIED ENGINEERING PRODUCTS

(203) 776-2813 • FAX (203) 776-8294

www.aepconnectors.com • aepsales@aepconnectors.com

SMA Hermetic Seal Launchers

For hermetic seals with .012" diameter pins

Straight Plugs

1/2" Square Flange

9047-9513-000

Optional packaging:

9147-9513-000 (Includes 920-55)

9247-9513-000 (Includes 920-55 and 907-111-1)

9347-9513-000 (Includes 907-111-1)

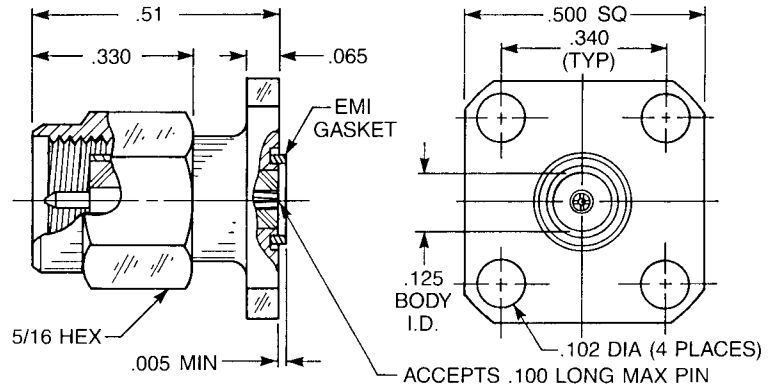

2-Hole Flange

9046-9513-000

Optional packaging:

9146-9513-000 (Includes 920-55)

9246-9513-000 (Includes 920-55 and 907-111-1)

9346-9513-000 (Includes 907-111-11)

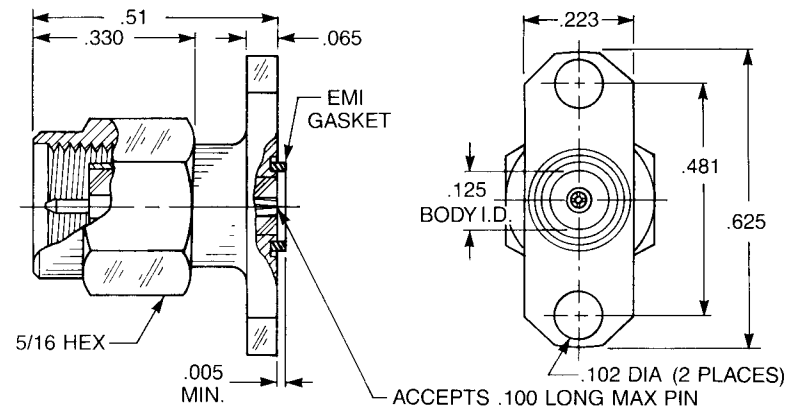

These units accept hermetic seal pin diameters .011-.015"

Hermetic Seal and Accessory Contact

Solder-In Hermetic Seal

P/N 920-55

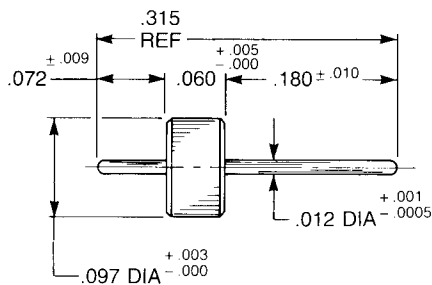

Accessory Contact

P/N 907-111-1

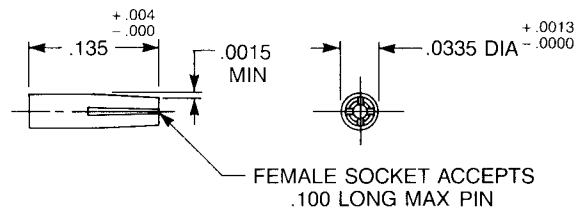

Material: Beryllium copper

Finish: Gold per MIL-G-45204, type II, class I, grade C, over .0001 copper per MIL-C-14550

SMA Hermetic Seal Launchers

For hermetic seals with .015" diameter pins

Straight Jacks

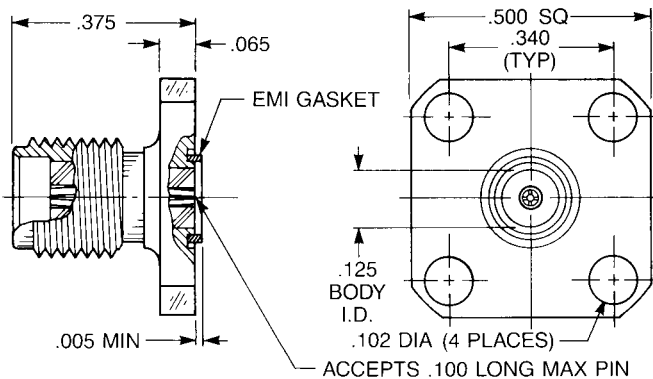

1/2" Square Flange

9045-9513-001

Optional packaging:

9145-9513-001 (Includes 920-82)

9245-9513-001 (Includes 920-82 and 907-111-5)

9345-9513-001 (Includes 907-111-5)

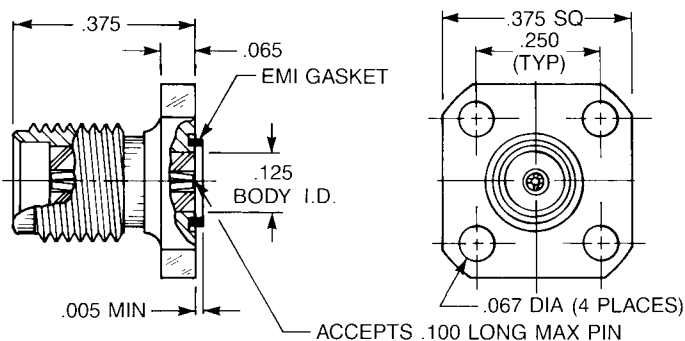

3/8" Square Flange

9079-9513-001

Optional packaging:

9179-9513-001 (Includes 920-82)

9279-9513-001 (Includes 920-82 and 907-111-5)

9379-9513-001 (Includes 907-111-5)

Rectangular Flange

9062-9513-001

Optional packaging:

9162-9513-001 (Includes 920-82)

9262-9513-001 (Includes 920-82 and 907-111-5)

9362-9513-001 (Includes 907-111-5)

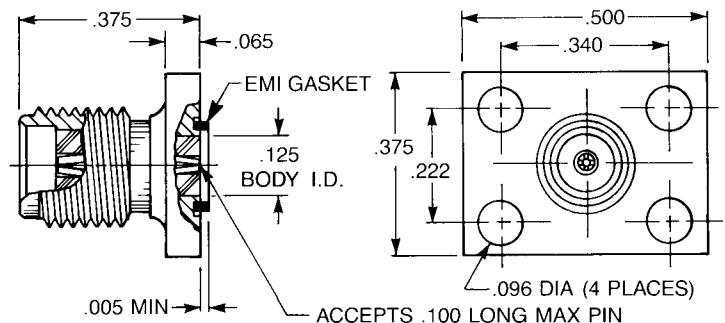

These units accept hermetic seal pin diameters .014-.016"

Hermetic Seal and Accessory Contact

Solder-In Hermetic Seal

P/N 920-82

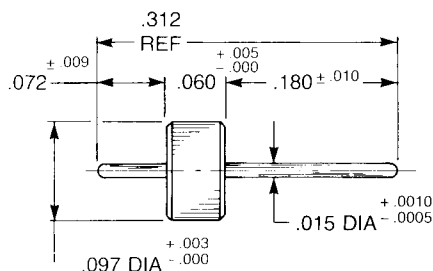

Accessory Contact

P/N 907-111-5

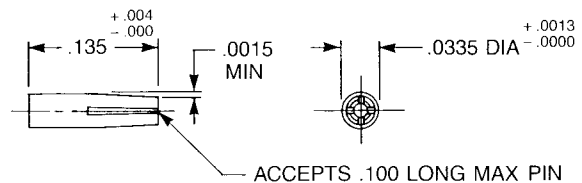

Material: Beryllium copper.

Finish: Gold per MIL-G-45204, type II, class 1, grade C, over .0001 copper per MIL-C-14450.

SMA Hermetic Seal Launchers

For hermetic seals with .015" diameter pins

Straight Jacks

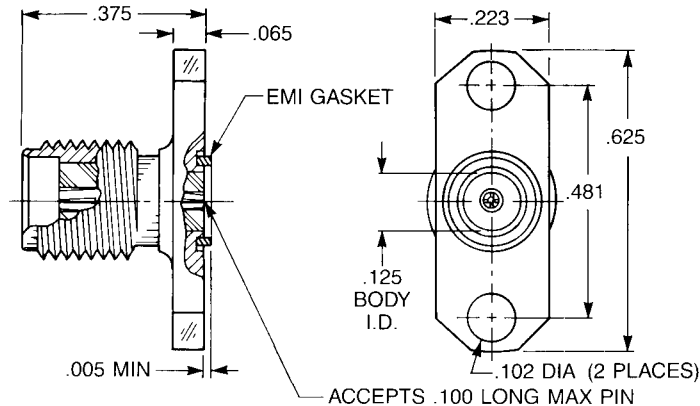

2-Hole Flange

9044-9513-001

Optional packaging:

9144-9513-001 (Includes 920-82)

9244-9513-001 (Includes 920-82

and 907-111-5)

9344-9513-001 (Includes 907-111-5)

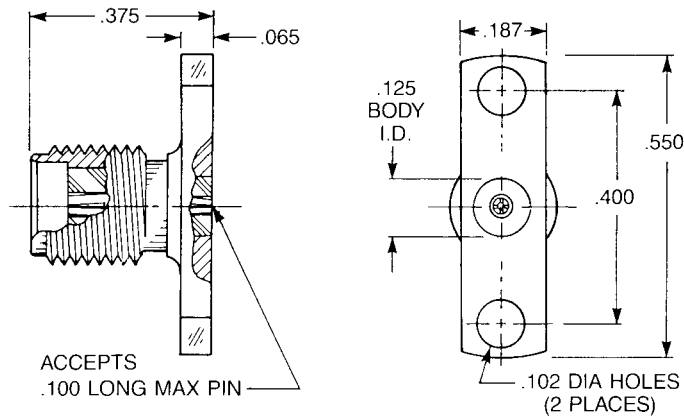

Narrow 2-Hole Flange

No EMI gasket

9080-9513-001

Optional packaging:

9180-9513-001 (Includes 920-82)

9280-9513-001 (Includes 920-82

and 907-111-5)

9380-9513-001 (Includes 907-111-5)

These units accept hermetic seal pin diameters .014-.016"

Hermetic Seal and Accessory Contact

Solder-In Hermetic Seal

P/N 920-82

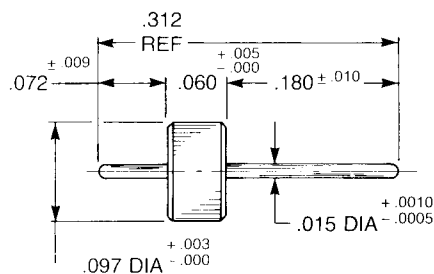

Accessory Contact

P/N 907-111-5

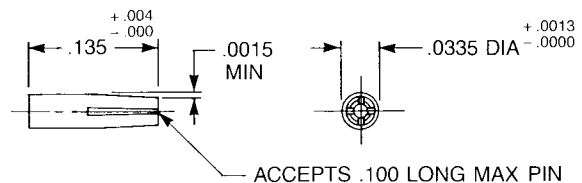

Material: Beryllium copper.

Finish: Gold per MIL-G-45204, type II, class 1, grade C, over .0001 copper per MIL-C-14450.

SMA Hermetic Seal Launchers

For hermetic seals with .015" diameter pins

Straight Plugs

1/2" Square Flange

9047-9513-001

Optional packaging:

9147-9513-001 (Includes 920-82)

9247-9513-001 (Includes 920-82 and 907-111-5)

9347-9513-001 (Includes 907-111-5)

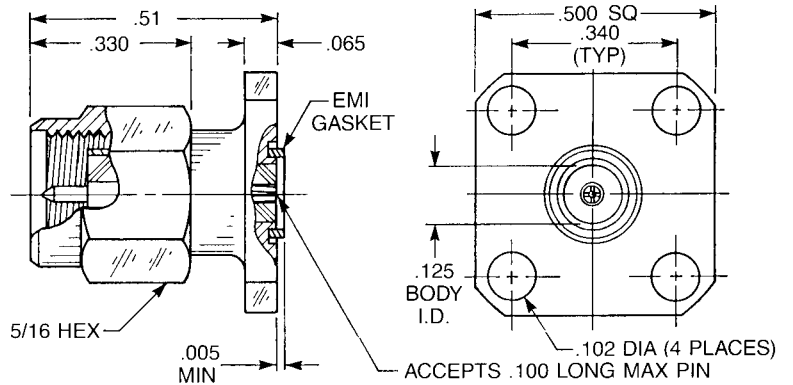

2-Hole Flange

9046-9513-001

Optional packaging:

9146-9513-001 (Includes 920-82)

9246-9513-001 (Includes 920-82 and 907-111-5)

9346-9513-001 (Includes 907-111-5)

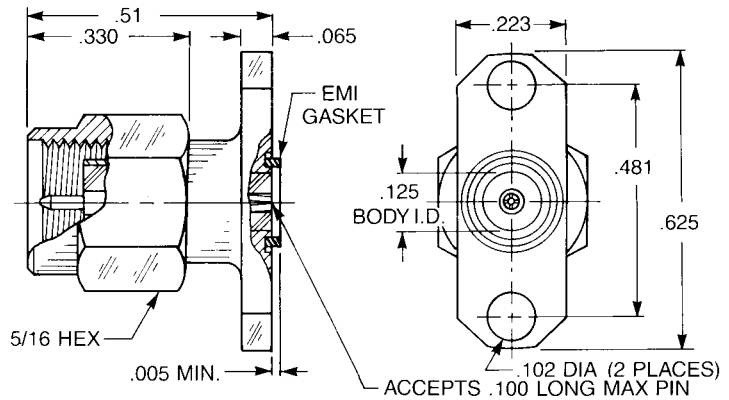

These units accept hermetic seal pin diameters .014-.016"

Hermetic Seal and Accessory Contact

Solder-In Hermetic Seal

P/N 920-82

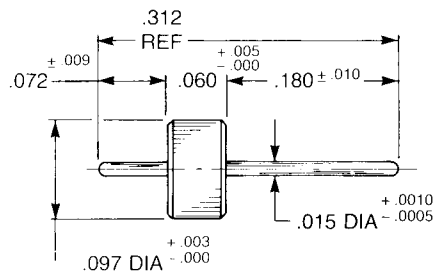

Accessory Contact

P/N 907-111-5

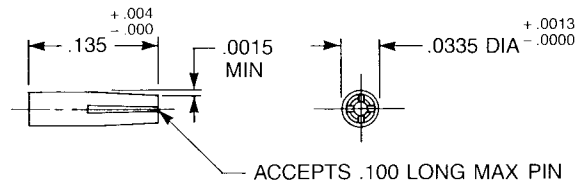

Material: Beryllium copper.

Finish: Gold per MIL-G-45204, type II, class 1, grade C, over .0001 copper per MIL-C-14450.



APPLIED ENGINEERING PRODUCTS

(203) 776-2813 • FAX (203) 776-8294

www.aepconnectors.com • aepsales@aepconnectors.com

SMA Hermetic Seal Launchers

For hermetic seals with .018" diameter pins

Straight Jacks

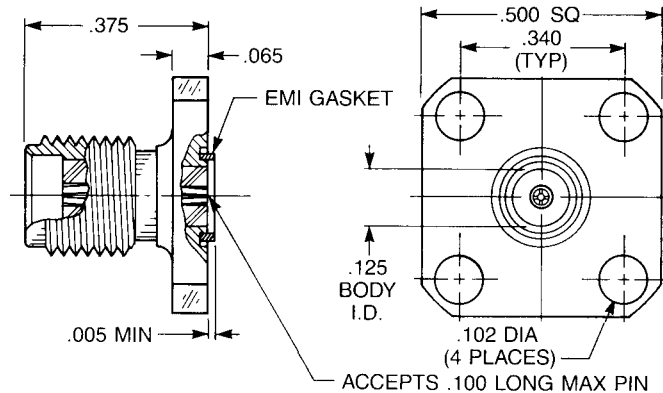

1/2" Square Flange

9049-9513-000

Optional packaging:

9149-9513-000 (Includes 920-56)

9249-9513-000 (Includes 920-56 and 907-111-2)

9349-9513-000 (Includes 907-111-2)

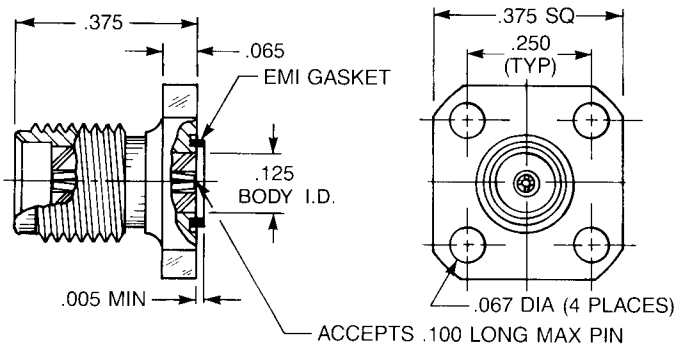

3/8" Square Flange

9074-9513-000

Optional packaging:

9174-9513-000 (Includes 920-56)

9274-9513-000 (Includes 920-56 and 907-111-2)

9374-9513-000 (Includes 907-111-2)

Rectangular Flange

9068-9513-000

Optional packaging:

9168-9513-000 (Includes 920-56)

9268-9513-000 (Includes 920-56 and 907-111-2)

9368-9513-000 (Includes 907-111-2)

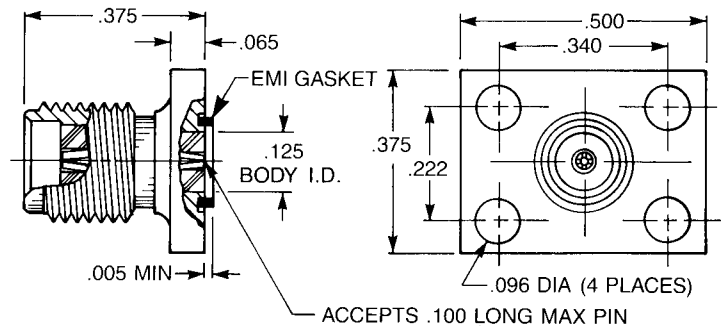

These units accept hermetic seal pin diameters .016-.020"

Hermetic Seal and Accessory Contact

Solder-In Hermetic Seal

P/N 920-56

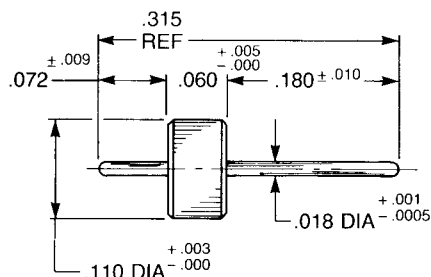

Accessory Contact

P/N 907-111-2

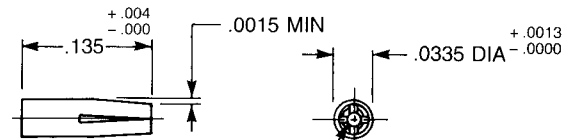

ACCEPTS .100 LONG MAX PIN

Material: Beryllium copper

Finish: Gold per MIL-G-45204, type II, class 1, grade C over .0001 copper per MIL-C-14450



APPLIED ENGINEERING PRODUCTS

(203) 776-2813 • FAX (203) 776-8294

www.aepconnectors.com • aepsales@aepconnectors.com

SMA Hermetic Seal Launchers

For hermetic seals with .018" diameter pins

Straight Jacks

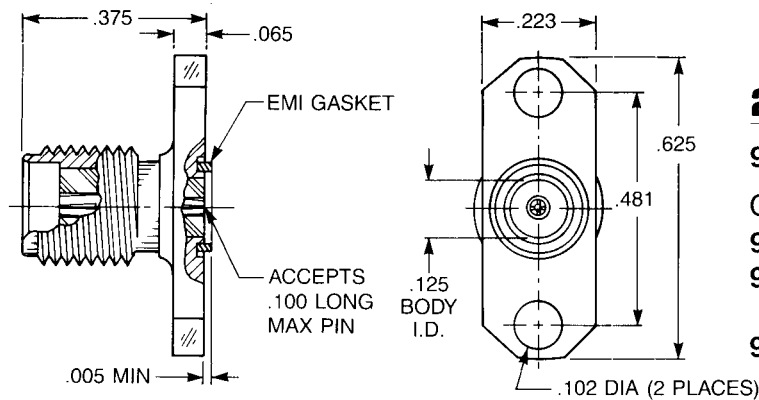

2-Hole Flange

9048-9513-000

Optional packaging:

9148-9513-000 (Includes 920-56)

9248-9513-000 (Includes 920-56 and 907-111-2)

9348-9513-000 (Includes 907-111-2)

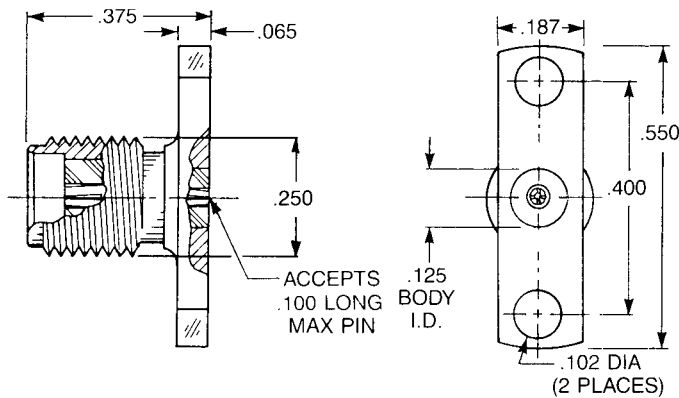

Narrow 2-Hole Flange

No EMI gasket

9081-9513-000

Optional packaging:

9181-9513-000 (Includes 920-56)

9281-9513-000 (Includes 920-56 and 907-111-2)

9381-9513-000 (Includes 907-111-2)

These units accept hermetic seal pin diameters .016-.020"

Hermetic Seal and Accessory Contact

Solder-In Hermetic Seal

P/N 920-56

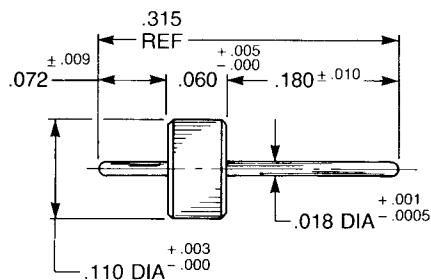

Accessory Contact

P/N 907-111-2

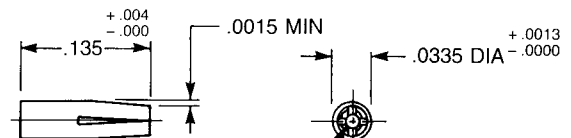

ACCEPTS .100 LONG MAX PIN

Material: Beryllium copper

Finish: Gold per MIL-G-45204, type II, class 1, grade C over .0001 copper per MIL-C-14450

SMA Hermetic Seal Launchers

For hermetic seals with .018" diameter pins

Straight Plugs

1/2" Square Flange

9051-9513-000

Optional packaging:

9151-9513-000 (Includes 920-56)

9251-9513-000 (Includes 920-56 and 907-111-2)

9351-9513-000 (Includes 907-111-2)

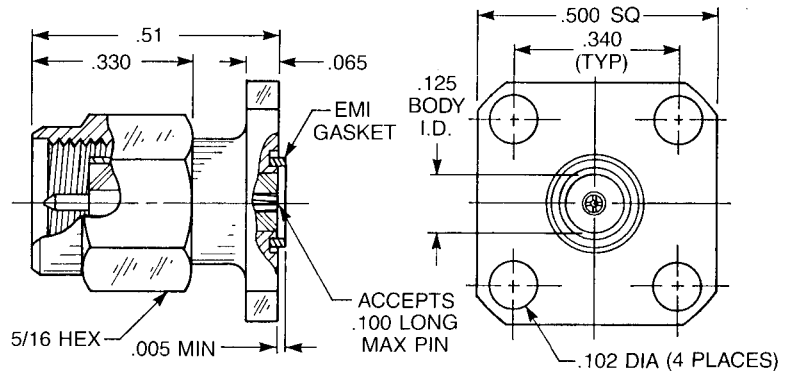

2-Hole Flange

9050-9513-000

Optional packaging:

9150-9513-000 (Includes 920-56)

9250-9513-000 (Includes 920-56 and 907-111-2)

9350-9513-000 (Includes 907-111-2)

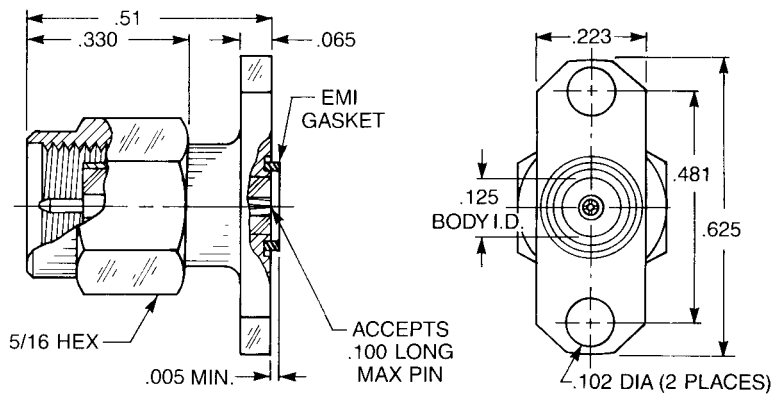

These units accept hermetic seal pin diameters .016-.020"

Hermetic Seal and Accessory Contact

Solder-In Hermetic Seal

P/N 920-56

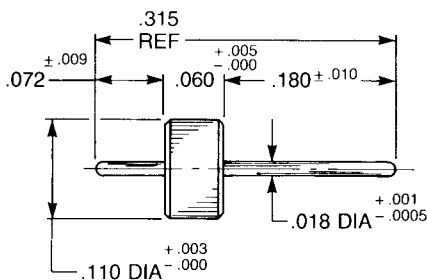

Accessory Contact

P/N 907-111-2

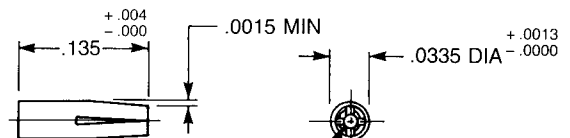

ACCEPTS .100 LONG MAX PIN

Material: Beryllium copper

Finish: Gold per MIL-G-45204, type II, class 1, grade C over .0001 copper per MIL-C-14450



APPLIED ENGINEERING PRODUCTS

(203) 776-2813 • FAX (203) 776-8294

www.aepconnectors.com • aepsales@aepconnectors.com

SMA Hermetic Seal Launchers

For hermetic seals with .020" diameter pins

Straight Jacks

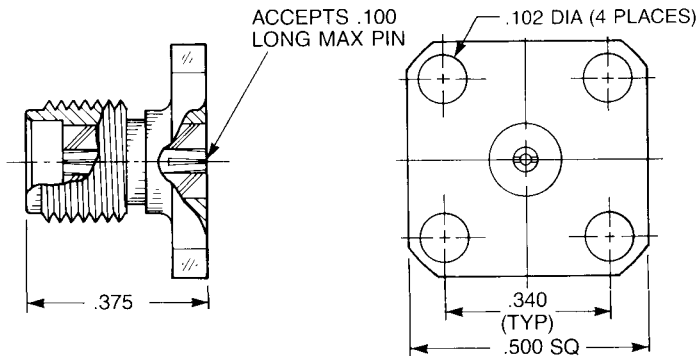

Straight Jack 1/2" Square Flange

9504-9113-031

9504-9113-034 (Includes 920-69)

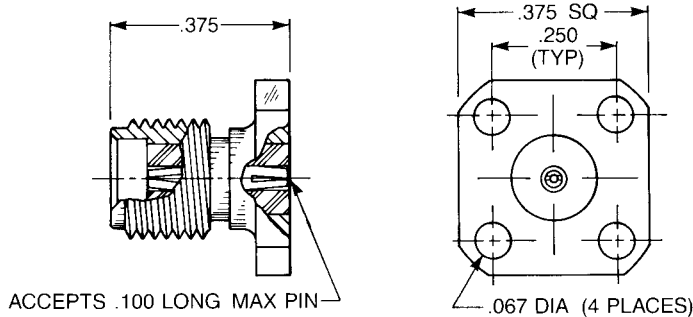

Straight Jack 3/8" Square Flange

9576-9113-001

9576-9113-002 (Includes 920-69)

Straight Jack Rectangular Flange

9507-9113-003

9507-9113-004 (Includes 920-69)

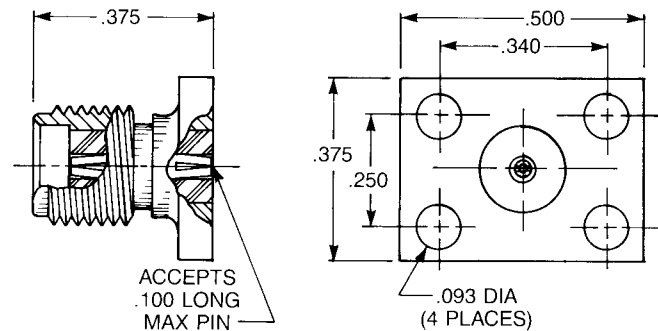

Hermetic Seal and Accessory Contact

Solder-In Hermetic Seal

P/N 920-69

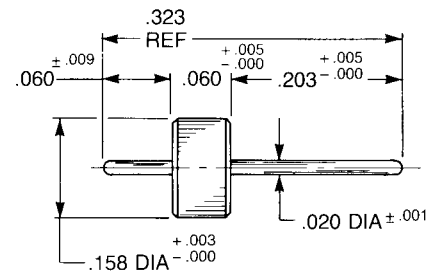

SMA Hermetic Seal Launchers

For hermetic seals with .020" diameter pins

Straight Jacks

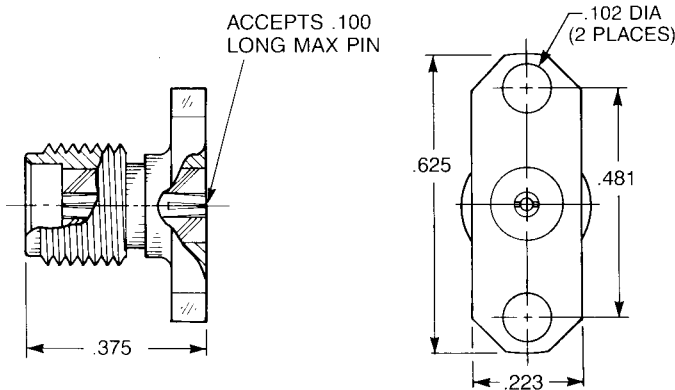

Straight Jack 2-Hole Flange

9508-9113-002
9508-9113-003 (Includes 920-69)

Straight Jack Screw-In Mounting

9513-9113-009
9513-9113-012 (Includes 920-69)
These connectors require a minimum package wall thickness of .250" for proper retention

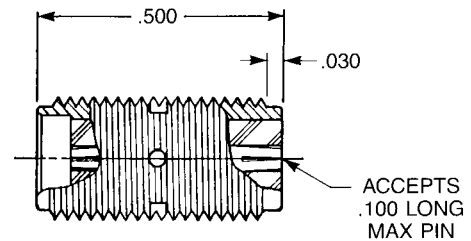

Straight Jack Knurl Mount

9533-9113-003
9533-9113-002 (Includes 920-69)

These connectors require a minimum package wall thickness of .235" for proper retention

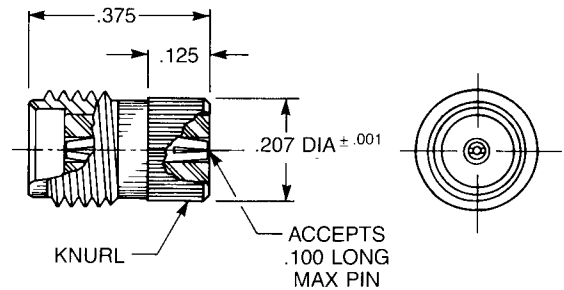

Hermetic Seal and Accessory Contact

Solder-In Hermetic Seal

P/N 920-69

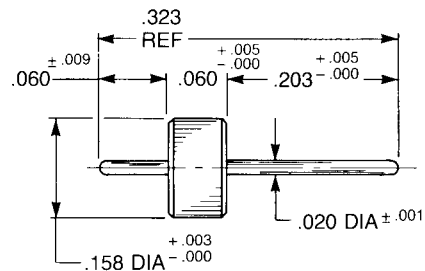

SMA Hermetic Seal Launchers

For hermetic seals with .036" diameter pins

Straight Jacks

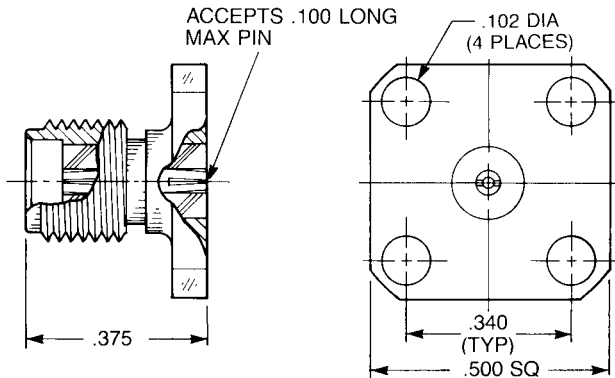

Straight Jack 1/2" Square Flange

9504-9113-009

9504-9113-035 (Includes 920-92)

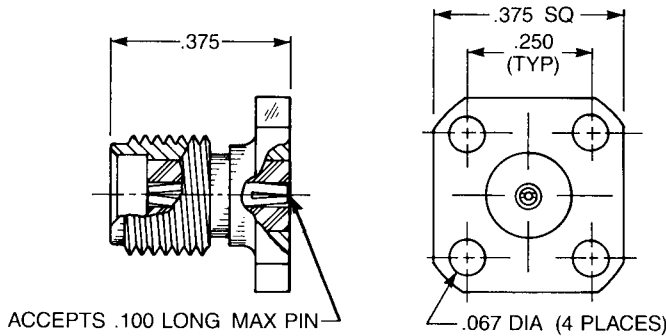

Straight Jack 3/8" Square Flange

9576-9113-003

9576-9113-004 (Includes 920-92)

Straight Jack Rectangular Flange

9507-9113-005

9507-9113-006 (Includes 920-92)

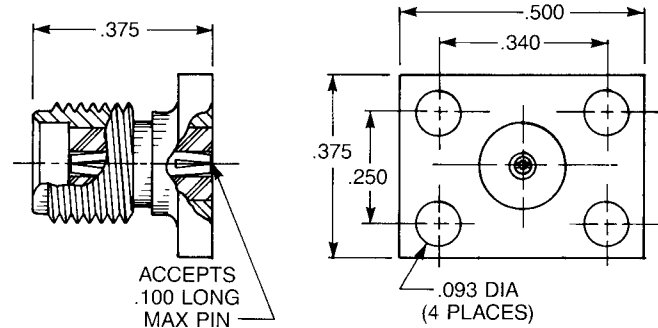

Hermetic Seal and Accessory Contact

Solder-In Hermetic Seal

P/N 920-92

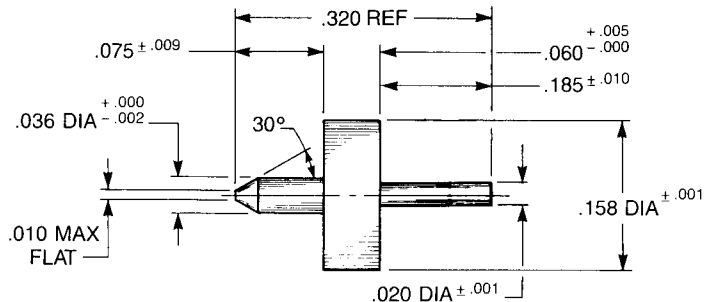

SMA Hermetic Seal Launchers

For hermetic seals with .036" diameter pins

Straight Jacks

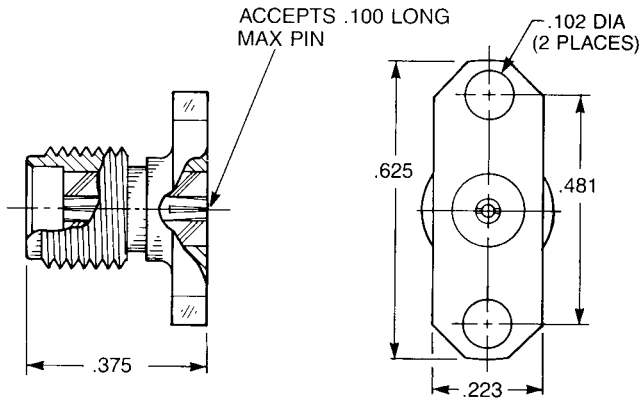

Straight Jack 2-Hole Flange

9508-9113-001

9508-9113-011 (Includes 920-92)

Straight Jack Screw-In Mounting

9513-9113-008

9513-9113-013 (Includes 920-92)

These connectors require a minimum package wall thickness of .250" for proper retention

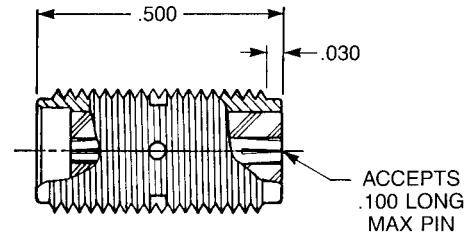

Straight Jack Knurl Mount

9533-9113-001

9533-9113-004 (Includes 920-92)

These connectors require a minimum package wall thickness of .235" for proper retention.

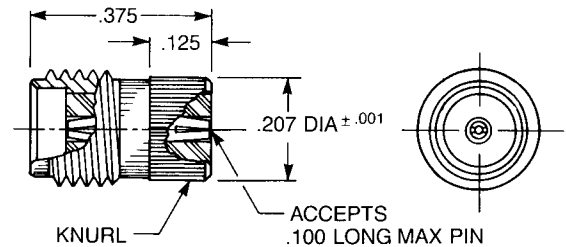

Hermetic Seal and Accessory Contact

Solder-In Hermetic Seal

P/N 920-92

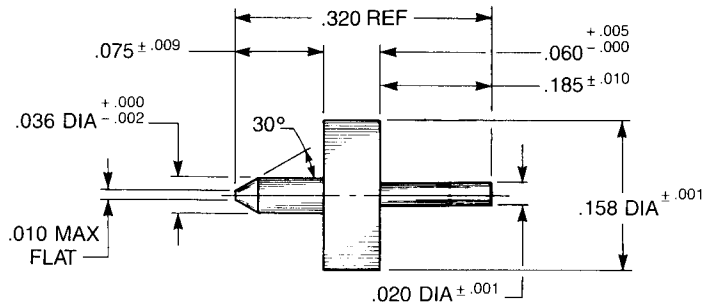

APPLIED ENGINEERING PRODUCTS

(203) 776-2813 • FAX (203) 776-8294

www.aepconnectors.com • aepsales@aepconnectors.com

SMA Adapters

Straight Adapters

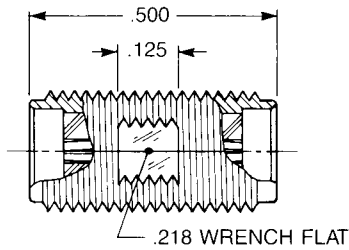

Straight Jack To Jack Adapter

- Connects two plugs

Captive contact:

5917-1103-000 (Gold plated)

5917-9103-000 (Passivated)

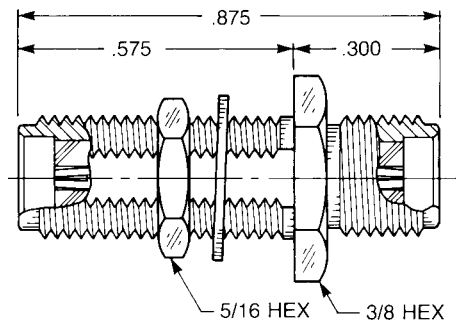

Straight Bulkhead Mounted Jack To Jack Adapter

- Connects two plugs

Captive contact:

5909-1103-000 (Gold plated)

5909-9103-000 (Passivated)

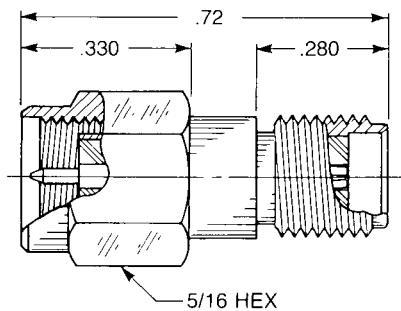

Straight Jack To Plug Adapter

- Prevents damage to equipment-mounted jacks during frequent mating and unmating

Captive contact:

5916-1103-603 (Gold plated)

5916-9103-603 (Passivated)

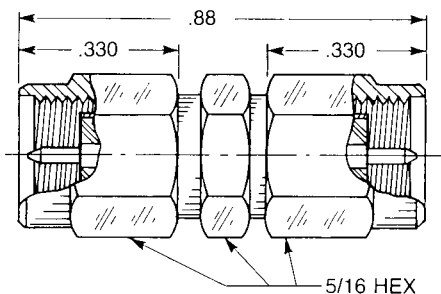

Straight Plug To Plug Adapter

- Connects two jacks

Captive contact:

5918-1103-000 (Gold plated)

5918-9103-000 (Passivated)



SMA Adapters

Right Angle Adapters

Right Angle Jack To Plug Adapter

- Connects one jack and one plug

5919-1503-000 (Gold plated)

5919-9503-000 (Passivated)

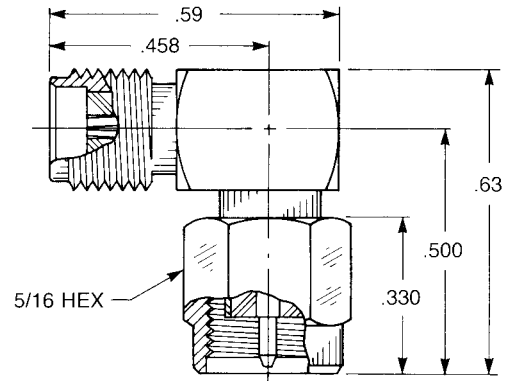

Right Angle Jack To Jack Adapter

- Connects two plugs

5919-1503-003 (Gold plated)

5919-9503-003 (Passivated)

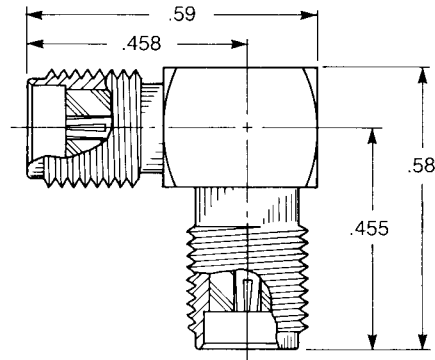

Right Angle Plug To Plug Adapter

- Connects two jacks

5919-1503-001 (Gold plated)

5919-9503-001 (Passivated)

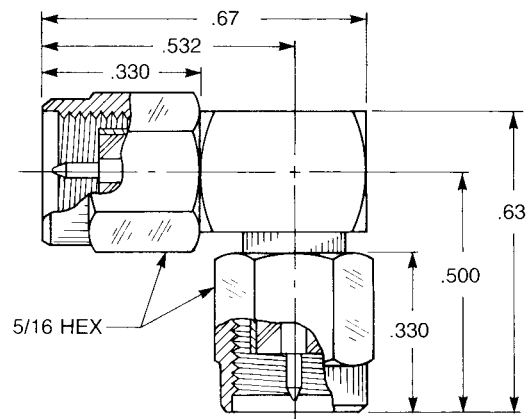

SMA Adapters

Tee Adapters

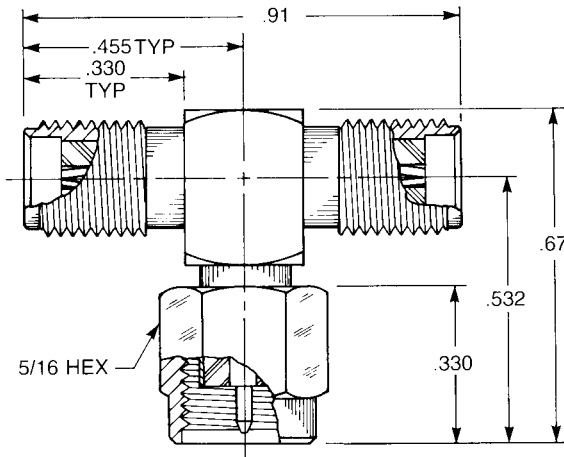

Tee Adapter (Unmatched Power Divider) Jack To Plug To Jack

- Connects two plugs and one jack

5905-1503-000 (Gold plated)

5905-9503-000 (Passivated)

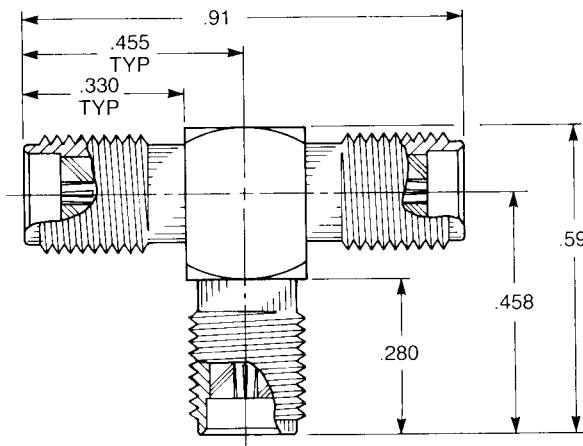

Tee Adapter (Unmatched Power Divider) Jack To Jack To Jack

- Connects three plugs

5903-1503-000 (Gold plated)

5903-9503-000 (Passivated)

SMA Terminations

Plug Termination

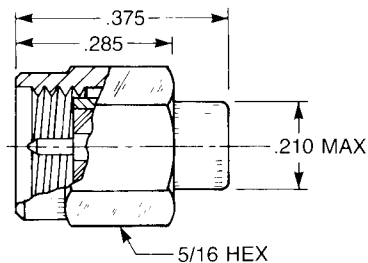

Plug Resistive Termination (Dummy Load)

- VSWR 1.15: 1 max. to 18 GHz.
- Maximum average power: 1 watt
- Peak power: 1.5 watts

9620-9003-151 (Passivated)

VSWR

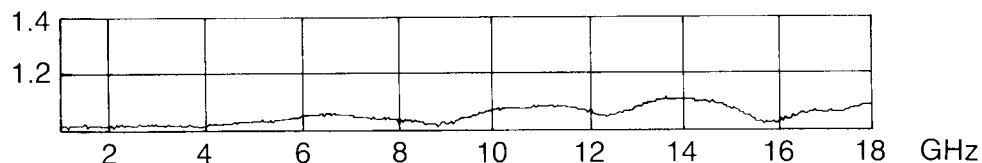

APPLIED ENGINEERING PRODUCTS

(203) 776-2813 • FAX (203) 776-8294

www.aepconnectors.com • aepsales@aepconnectors.com

Cable Assembly Instructions

Clamp type connectors for flexible cable

Straight Connectors—Flexible Cable

Parts list

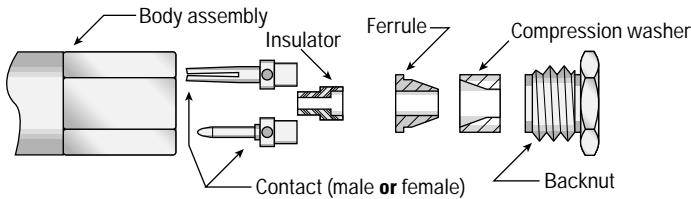

1

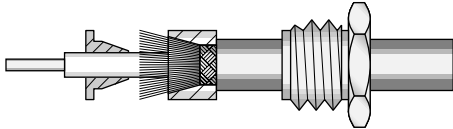

- Trim cable per trim code below; tin end of center conductor.
- Slide backnut onto cable. Slide compression washer onto cable in the orientation shown until it stops against cable jacket.
- Flare cable braid by rotating dielectric and slide ferrule under braid.

2

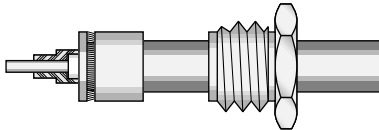

- Press ferrule against compression washer.
- Trim excess braid flush with outer diameter of compression washer and ferrule.
- Assemble insulator over cable center conductor and dielectric.

3

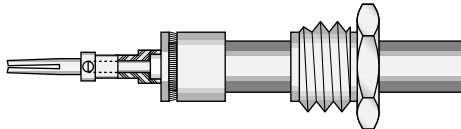

- Assemble contact onto cable center conductor.
- Solder contact to center conductor by heating rear of contact (do not feed additional solder through inspection hole in contact).

4

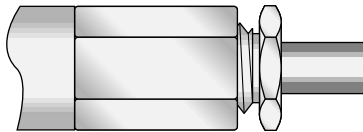

- Insert cable assembly into body assembly. Tighten to 140–150 inch-ounces torque. (Hold cable/hardware assembly stationary and rotate body when tightening.)

Cable Trim Dimensions

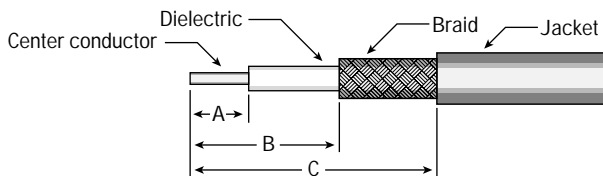

CONNECTOR TYPE	A	B	C
STRAIGHT CONNECTORS	.100	.100	.230
RIGHT ANGLE CONNECTORS	.100	.275	.400

Right Angle Connectors—Flexible Cable

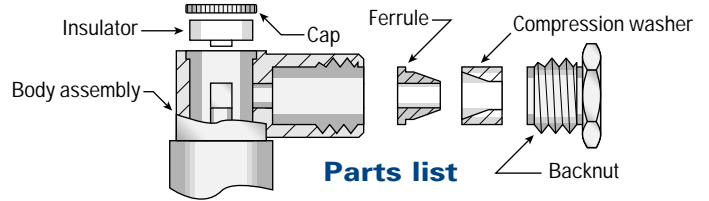

1

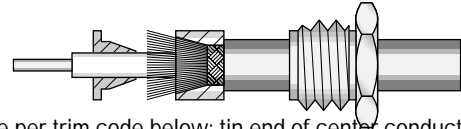

- Trim cable per trim code below; tin end of center conductor.
- Slide backnut onto cable. Slide compression washer onto cable in the orientation shown until it stops against cable jacket.
- Flare cable braid by rotating dielectric and slide ferrule under braid.

2

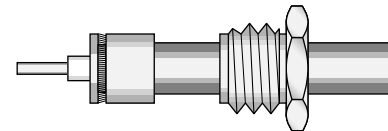

- Press ferrule against compression washer.
- Trim excess braid flush with outer diameter of compression washer and ferrule.
- Assemble insulator over cable center conductor and dielectric.

3

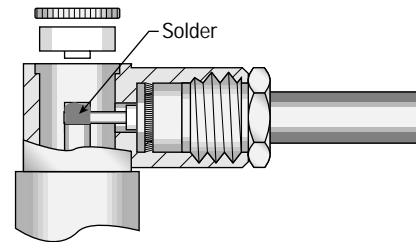

- Insert cable assembly into body assembly. Tighten to 140–150 inch-ounces torque. (Hold cable/hardware assembly stationary and rotate body when tightening.)
- Solder center conductor into notch in rear of contact with .025–.032" diameter chisel-tip soldering iron.
- Solder should cover center conductor, but not extend over top of notch in contact, or exceed contact diameter.

4

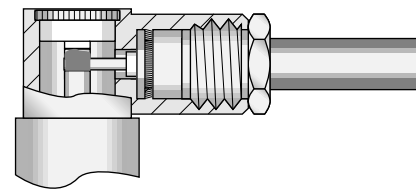

- Place insulator in body cavity, and press cap into place. Properly assembled cap will be slightly below end of body assembly.

Cable Assembly Instructions

Crimp type connectors for flexible cable

Straight Connectors—Captive Contact

Parts list

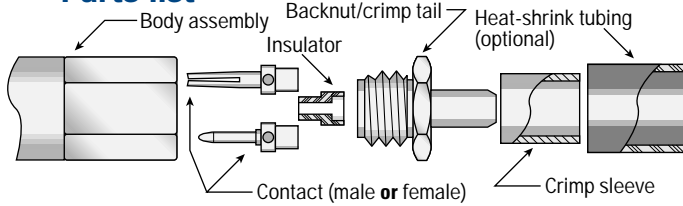

1

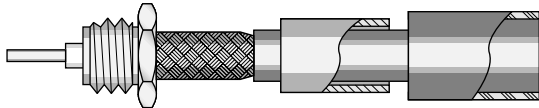

- Trim cable per trim code below; tin end of center conductor.
- Slide heat-shrink tubing and crimp sleeve over cable.
- Flare cable braid by rotating dielectric and slide cable into crimp tail.

2

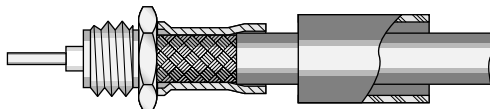

- Position cable so braid touches rear of back nut.
- Slide crimp sleeve forward to touch rear of back nut.
- Crimp braid with appropriate die size from chart below.

3

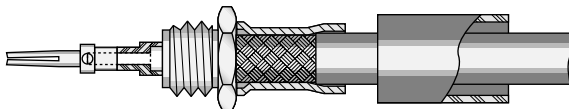

- Assemble insulator and contact onto cable dielectric and center conductor.
- Solder contact to center conductor by heating rear of contact (do not feed additional solder through inspection hole in contact).

4

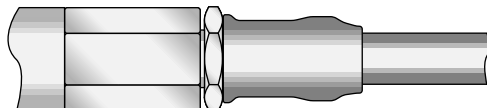

- Insert cable assembly into body assembly. Tighten to 140–150 inch-ounces torque. (Hold cable/hardware assembly stationary and rotate body when tightening.)
- Slide shrink tubing over crimp sleeve and shrink to fit.

Straight Connectors—Non-captive Contact

Parts list

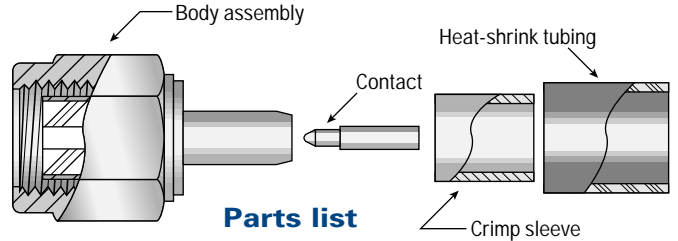

1

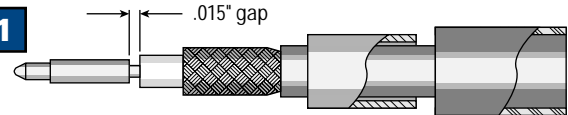

- Trim cable per trim code below; tin end of center conductor.
- Slide heat-shrink tubing and crimp sleeve over cable.
- Assemble contact onto center conductor, shim to maintain .015" gap between rear of contact and cable dielectric.
- Solder contact to center conductor by heating rear of contact (do not feed additional solder through inspection hole in contact).

2

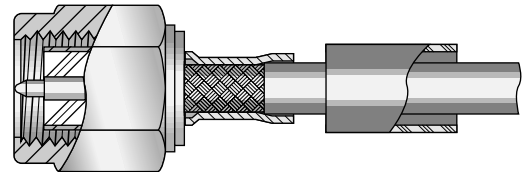

- Flare cable braid by rotating dielectric and slide cable into tail of body assembly.
- Position cable so braid touches rear step of body assembly.
- Slide crimp sleeve forward to touch rear of body assembly.
- Crimp braid with appropriate die size from chart below.

3

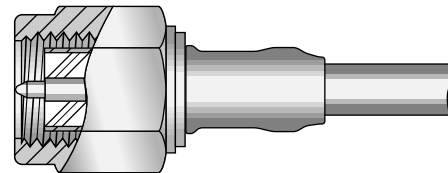

- Slide shrink tubing over crimp sleeve and shrink to fit.

Crimp Die Sizes

CABLE GROUP	HEX DIE SIZE
01	.213
02	.128
03	.128
04	.156
05	.128
06	.213
19	.156

Cable Trim Dimensions

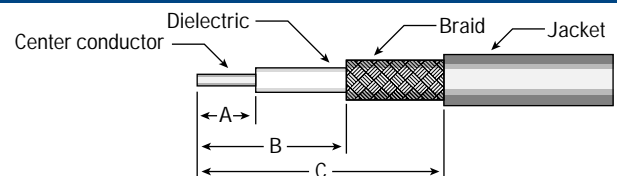

CONNECTOR TYPE	A	B	C
Captive contact	.100	.470	.720
Non-captive contact	.100	.160	.390

Cable Assembly Instructions

Crimp type connectors for flexible cable

Right Angle Connectors—Flexible Cable

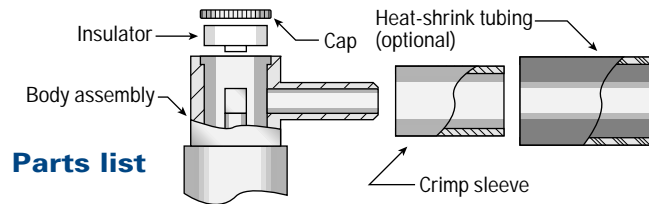

Cable Trim Dimensions

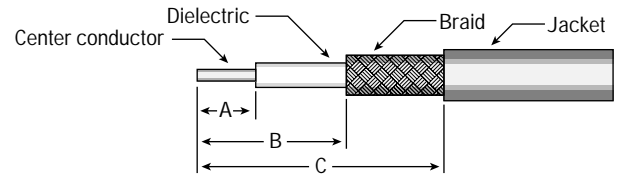

CONNECTOR TYPE	A	B	C
RIGHT ANGLE CONNECTORS	.100	.230	.500

Crimp Die Sizes

CABLE GROUP	HEX DIE SIZE
01	.213
02	.128
03	.128
04	.156
05	.128
06	.213
19	.156

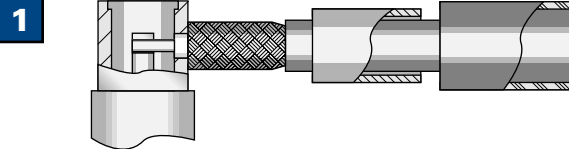

- Trim cable per trim code below; tin end of center conductor.
- Slide heat-shrink tubing and crimp sleeve over cable.
- Flare cable braid by rotating dielectric and slide cable into crimp tail.

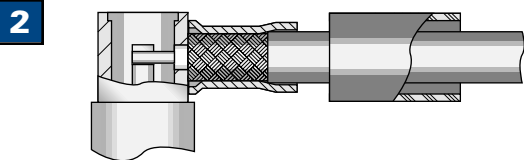

- Position cable so braid touches rear of body assembly.
- Slide crimp sleeve forward to touch rear of body assembly.
- Crimp braid with appropriate die size from chart below.

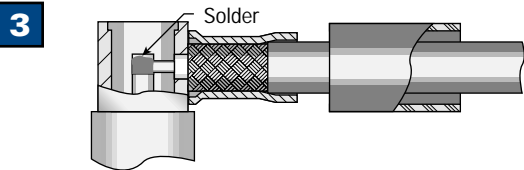

- Solder center conductor into notch in rear of contact with .025–.032" diameter chisel-tip soldering iron.
- Solder should cover center conductor, but not extend over top of notch in contact, or exceed contact diameter.

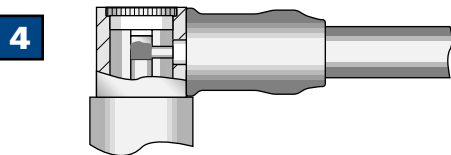

- Place insulator in body cavity, and press cap into place. Properly assembled cap will be slightly below end of body assembly.
- Slide shrink tubing over crimp sleeve and shrink to fit.

Cable Assembly Instructions

Solder-clamp connectors for semi-rigid cable

Straight Connectors—Semi-Rigid Cable

Parts list

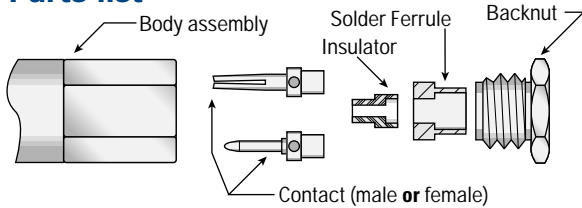

1

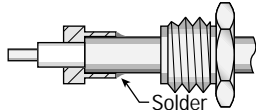

- Trim cable per trim code below; tin end of center conductor.
- Slide backnut over cable. Slide solder ferrule over cable until it stops against cable jacket.
- Solder cable jacket to ferrule.

2

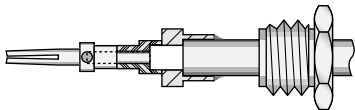

- Assemble insulator and contact onto cable dielectric and center conductor. If insulator is not flush against solder ferrule due to dielectric extrusion, retrim dielectric.
- Solder contact to center conductor by heating rear of contact (do not feed additional solder through inspection hole in contact).

3

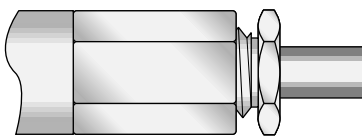

- Insert cable assembly into body assembly. Tighten to 90–100 inch-ounces torque. (Hold cable/hardware assembly stationary and rotate body when tightening.)

Cable Trim Dimensions

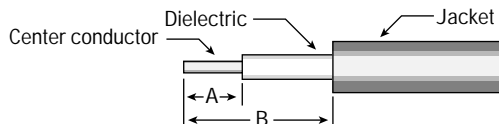

CONNECTOR TYPE	A	B
Straight connectors	.100	.135
Right angle connectors— .085" cable	.080	.170
Right angle connectors— .141" cable	.125	.290

Right Angle Connectors—Semi-Rigid Cable

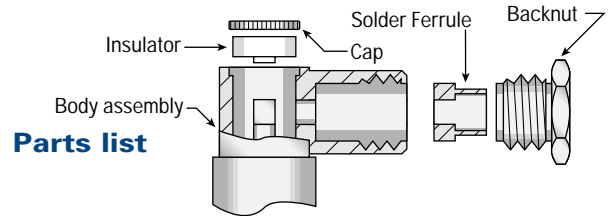

Parts list

1

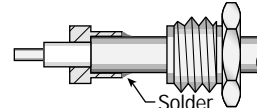

- Trim cable per trim code below; tin end of center conductor.
- Slide backnut over cable. Slide solder ferrule over cable until it stops against cable jacket.
- Solder cable jacket to ferrule.

2

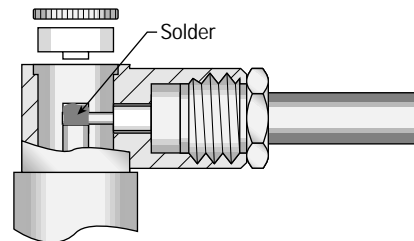

- Insert cable assembly into body assembly. Tighten to 90–100 inch-ounces torque. (Hold cable/hardware assembly stationary and rotate body when tightening.)
- Solder center conductor into notch in rear of contact with .025–.032" diameter chisel-tip soldering iron.
- Solder should cover center conductor, but not extend over top of notch in contact, or exceed contact diameter.

3

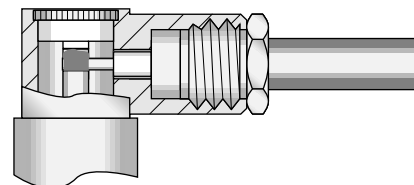

- Place insulator in body cavity, and press cap into place. Properly assembled cap will be slightly below end of body assembly.

Cable Assembly Instructions

Direct solder connectors for semi-rigid cable

Straight Connectors—Non-captive Contact

Parts list

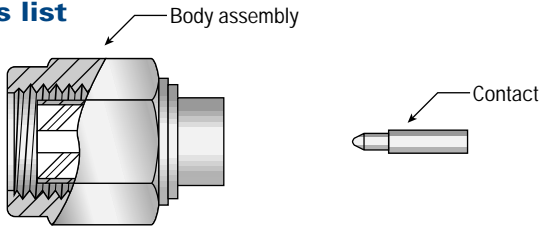

1

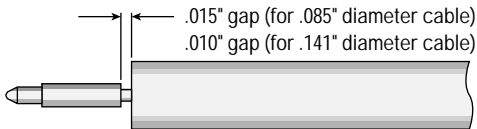

- Trim cable per trim code below; tin end of center conductor.
- Shim to maintain proper gap between rear of contact and cable dielectric.
- Solder contact to center conductor by heating rear of contact (do not feed additional solder through inspection hole in contact).

2

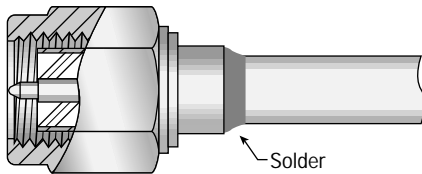

- Slide cable into connector until it stops.
- Solder cable jacket to connector body.

Cable Trim Dimensions

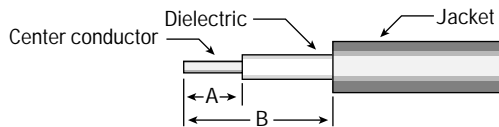

CONNECTOR TYPE	A	B
Straight connectors	.090	.090
Right angle connectors	.080	.170

Straight Connectors—Captive Contact

1

- Trim cable per trim code below; chamfer end of center conductor 70–90°.

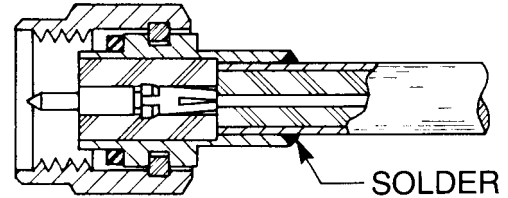

2

- Insert cable into body assembly until it stops.
- Solder cable jacket to connector body.

Right Angle Connectors

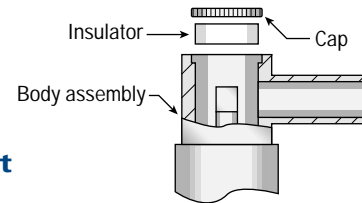

Parts list

1

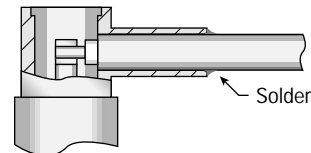

- Trim cable per trim code below; tin end of center conductor.
- Insert trimmed cable into body until jacket bottoms on step inside body and center conductor is in contact slot.
- Solder cable jacket to body assembly.

2

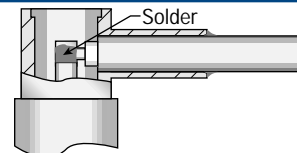

- Solder center conductor into notch in rear of contact with .025–.032" diameter chisel-tip soldering iron.
- Solder should cover center conductor, but not extend over top of notch in contact, or exceed contact diameter.

3

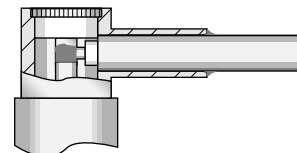

- Place insulator in body cavity, and press cap into place. Properly assembled cap will be slightly below end of body assembly.

Cable Assembly Instructions

Direct solder connectors for semi-rigid cable

P/N 9301-1063-009

Parts list

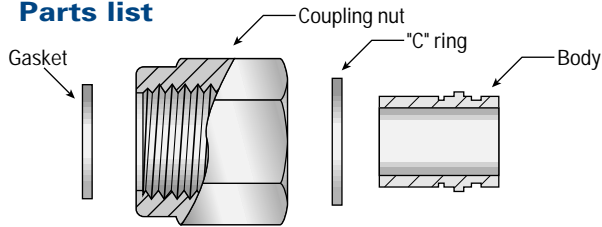

1

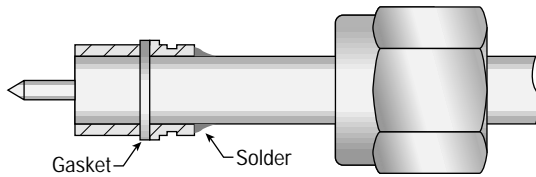

- Trim cable per trim code below; point end of center conductor to 45° as shown.
- Slide backnut over cable. Slide body over cable until trimmed end of cable is flush with front of body.
- Solder cable jacket to body. Retrim cable dielectric flush with body if it has extruded due to heat from soldering.
- Assemble gasket into groove on body.

2

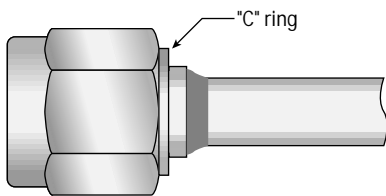

- Slide coupling nut forward until it stops and assemble "C" ring into groove.

P/N 9301-1063-109

Parts list

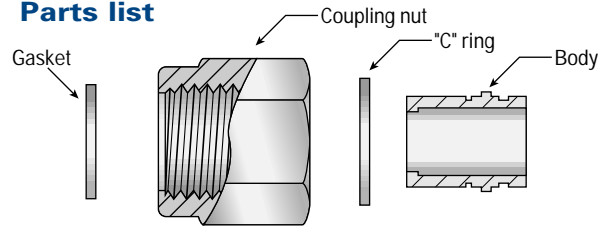

1

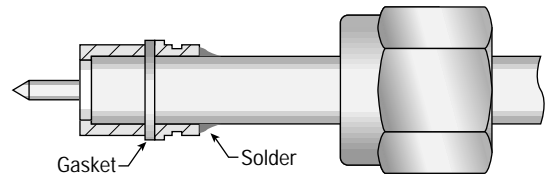

- Trim cable per trim code below; point end of center conductor to 45° as shown.
- Slide backnut over cable. Slide body over cable until trimmed end of cable jacket stops against step in body.
- Solder cable jacket to body. Retrim cable dielectric flush with body if it has extruded due to heat from soldering.
- Assemble gasket into groove on body.

2

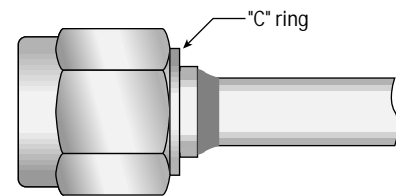

- Slide coupling nut forward until it stops and assemble "C" ring into groove.

Cable Trim Dimensions

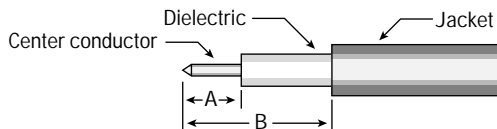

CONNECTOR TYPE	A	B
9301-1063-009	.090	.090
9301-1063-109	.090	.180



Assembly Tooling

Crimp tools

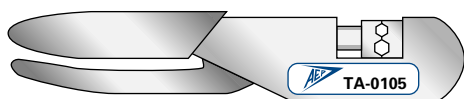

DESCRIPTION	AEP P/N
Crimp tool with .128" and .213" hex dies	TA-0007
Crimp tool with .156" hex die	TA-0071
Crimp tool with .105" and .128" hex dies	TA-0105
Crimp tool with .255" and .068" hex dies	TA-0190
Crimp tool with .255" hex die	TA-0234

Torque Wrench



DESCRIPTION	AEP P/N
Torque wrench with 5/16" jaw for SMA coupling nuts; 8 inch-pounds torque	TA-0397

Capping Press

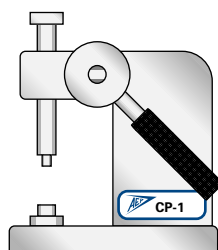

DESCRIPTION	AEP P/N
Capping tool (arbor press) with base for SMA right angle plugs	Contact Factory
Capping tool (arbor press) with base for SMA right angle jacks	Contact Factory

Mounting Dimensions

Bulkhead Receptacles

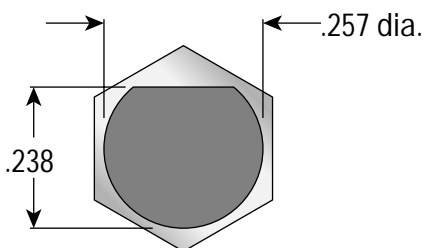

P.C. Board Receptacles

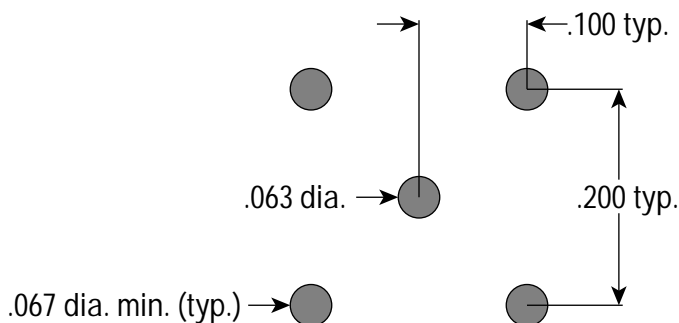

Index by Part Number

P/N	Page	P/N	Page	P/N	Page
5903-1503-000	48	9031-1023-0XX	15	9102-1573-0XX	11
5903-9503-000	48	9031-1033-0XX	15	9102-9573-0XX	11
5905-1503-000	48	9031-9023-0XX	15	9104-1113-000	18
5905-9503-000	48	9033-1113-000	28	9104-1213-000	18
5909-1103-000	46	9033-1213-000	28	9104-9113-000	18
5909-9103-000	46	9033-9113-000	28	9104-9213-000	18
5916-1103-603	46	9033-9213-000	28	9107-1113-000	18
5916-9103-603	46	9034-1213-0XX	30	9107-1213-000	18
5917-1103-000	46	9034-9213-0XX	30	9107-9113-000	18
5917-9103-000	46	9035-1513-0XX	30	9107-9213-000	18
5918-1103-000	46	9035-9513-0XX	30	9108-1113-000	18
5918-9103-000	46	9043-1523-0XX	9	9108-1213-000	18
5919-1503-000	47	9043-1533-0XX	9	9108-9113-000	18
5919-1503-001	47	9043-9523-0XX	9	9108-9213-000	18
5919-1503-003	47	9044-9513-000	34	9109-1113-000	25
5919-9503-000	47	9044-9513-001	37	9109-1213-000	25
5919-9503-001	47	9045-9513-000	33	9109-9113-000	25
5919-9503-003	47	9045-9513-001	36	9109-9213-000	25
9001-1023-0XX	8	9046-9513-000	35	9114-1113-000	21
9001-1033-0XX	8	9046-9513-001	38	9114-9113-000	21
9001-9023-0XX	8	9047-9513-000	35	9117-1113-000	21
9002-1023-0XX	11	9047-9513-001	38	9117-9113-000	21
9002-1033-0XX	11	9048-9513-000	40	9118-1113-000	21
9002-9023-0XX	11	9049-9513-000	39	9118-9113-000	21
9003-1213-0XX	30	9050-9513-000	41	9124-1513-000	20
9003-9213-0XX	30	9051-9513-000	41	9124-9513-000	20
9004-1113-000	16	9055-1113-000	23	9126-1513-000	20
9004-1213-000	16	9055-1213-000	23	9126-9513-000	20
9004-9113-000	16	9055-9113-000	23	9130-1573-0XX	13
9004-9213-000	16	9055-9213-000	23	9130-9573-0XX	13
9007-1113-000	16	9056-1113-000	27	9131-1573-0XX	15
9007-1213-000	16	9056-9113-000	27	9131-9573-0XX	15
9007-9113-000	16	9062-9513-000	33	9133-1113-000	28
9007-9213-000	16	9062-9513-001	36	9133-1213-000	28
9008-1113-000	16	9068-9513-000	39	9133-9113-000	28
9008-1213-000	16	9074-9513-000	39	9133-9213-000	28
9008-9113-000	16	9076-1113-000	16	9139-1113-000	28
9008-9213-000	16	9076-1213-000	16	9139-1213-000	28
9009-1113-000	23	9076-9113-000	16	9139-9113-000	28
9009-1213-000	23	9076-9213-000	16	9139-9213-000	28
9009-9113-000	23	9079-9513-000	33	9144-9513-000	34
9009-9213-000	23	9079-9513-001	36	9144-9513-001	37
9013-1113-000	27	9080-9513-000	34	9145-9513-000	33
9013-9113-000	27	9080-9513-001	37	9145-9513-001	36
9030-1023-0XX	13	9081-9513-000	40	9146-9513-000	35
9030-1033-0XX	13	9101-1573-0XX	8	9146-9513-001	38
9030-9023-0XX	13	9101-9573-0XX	8	9147-9513-000	35

Numbers ending with -0XX indicate connectors with various types on specified page.

Continued on next page



Index by Part Number

P/N	Page	P/N	Page	P/N	Page
9147-9513-001	38	9243-1553-0XX	9	9347-9513-001	38
9148-9513-000	40	9243-9553-0XX	9	9348-9513-000	40
9149-9513-000	39	9244-9513-000	34	9350-9513-000	41
9150-9513-000	41	9244-9513-001	37	9351-9513-000	41
9151-9513-000	41	9245-9513-000	33	9362-9513-000	33
9154-1513-000	25	9245-9513-001	36	9362-9513-001	36
9154-9513-000	25	9246-9513-000	35	9368-9513-000	39
9155-1113-000	25	9246-9513-001	38	9374-9513-000	39
9155-1213-000	25	9247-9513-000	35	9376-1113-001	22
9155-9113-000	25	9247-9513-001	38	9376-1113-002	22
9155-9213-000	25	9248-9513-000	40	9376-9113-001	22
9162-9513-000	33	9249-9513-000	39	9376-9113-002	22
9162-9513-001	36	9250-9513-000	41	9379-9513-000	33
9163-1113-000	21	9251-9513-000	41	9379-9513-001	36
9163-9113-000	21	9262-9513-000	33	9380-9513-000	34
9168-9513-000	39	9262-9513-001	36	9380-9513-001	37
9174-9513-000	39	9268-9513-000	39	9381-9513-000	40
9176-1113-000	18	9274-9513-000	39	9401-1083-010	6
9176-1213-000	18	9279-9513-000	33	9401-1083-109	6
9176-9113-000	18	9279-9513-001	36	9401-1083-210	7
9176-9213-000	18	9280-9513-000	34	9401-1583-010	6
9179-9513-000	33	9280-9513-001	37	9401-1583-109	6
9179-9513-001	36	9281-9513-000	40	9401-7083-010	6
9180-9513-000	34	9301-1063-009	6	9401-7083-109	6
9180-9513-001	37	9301-1063-109	6	9401-7083-210	7
9181-9513-000	40	9301-7063-009	6	9401-7583-010	6
920-55	33	9301-7063-109	6	9401-7583-109	6
920-56	39	9304-1113-013	22	9402-1083-009	10
920-69	42	9304-1113-014	22	9402-1083-010	10
920-82	36	9304-9113-013	22	9402-1583-009	10
920-92	44	9304-9113-014	22	9402-1583-010	10
9201-1553-0XX	8	9307-1113-001	22	9402-7083-009	10
9201-9553-0XX	8	9307-1113-002	22	9402-7083-010	10
9202-1553-0XX	11	9307-9113-001	22	9402-7583-009	10
9202-9553-0XX	11	9307-9113-002	22	9402-7583-010	10
9204-1113-0XX	19	9308-1113-001	22	9404-1113-000	17
9204-1213-0XX	19	9308-1113-003	22	9404-9113-000	17
9204-9113-0XX	19	9308-9113-001	22	9407-1113-000	17
9204-9213-0XX	19	9308-9113-003	22	9407-9113-000	17
9208-1113-0XX	19	9344-9513-000	34	9408-1113-000	17
9208-1213-0XX	19	9344-9513-000	39	9408-1113-002	17
9208-9113-0XX	19	9344-9513-001	37	9408-9113-000	17
9208-9213-0XX	19	9345-9513-000	33	9408-9113-002	17
9230-1553-0XX	13	9345-9513-001	36	9409-1113-000	24
9230-9553-0XX	13	9346-9513-000	35	9409-9113-000	24
9231-1553-0XX	15	9346-9513-001	38	9412-1113-000	26
9231-9553-0XX	15	9347-9513-000	35	9412-9113-000	26

Numbers ending with -0XX indicate connectors with various types on specified page.

Continued on next page



APPLIED ENGINEERING PRODUCTS

(203) 776-2813 • FAX (203) 776-8294

www.aepconnectors.com • aepsales@aepconnectors.com

Index by Part Number

P/N	Page	P/N	Page	P/N	Page
9413-1113-000	27	9456-9113-002	27	9610-1213-0XX	30
9413-9113-000	27	9476-1113-000	17	9610-9213-0XX	30
9422-1113-000	26	9476-9113-000	17	9613-1523-0XX	13
9422-9113-000	26	9501-1593-009	7	9613-1563-009	12
9424-1513-000	20	9501-1593-010	7	9613-1563-010	12
9424-9513-000	20	9501-9593-009	7	9613-7563-009	12
9425-1513-000	20	9501-9593-010	7	9613-7563-010	12
9425-9513-000	20	9502-1593-009	7	9613-9523-0XX	13
9431-1083-009	14	9502-1593-010	7	9620-9003-151	48
9431-1083-010	14	9502-9593-009	7	9646-1513-000	29
9431-1583-009	14	9502-9593-010	7	9647-1513-000	29
9431-1583-010	14	9504-9113-009	44	9649-1113-000	29
9431-7083-009	14	9504-9113-031	42	9650-1113-000	29
9431-7083-010	14	9504-9113-034	42	TA-0007	55
9431-7583-009	14	9504-9113-035	44	TA-0071	55
9431-7583-010	14	9507-9113-003	42	TA-0105	55
9432-1113-000	26	9507-9113-004	42	TA-0190	55
9432-9113-000	26	9507-9113-005	44	TA-0234	55
9433-1113-000	28	9507-9113-006	44	TA-0397	55
9433-9113-000	28	9508-9113-001	45		
9441-1083-009	14	9508-9113-002	43		
9441-1083-010	14	9508-9113-003	43		
9441-1583-009	14	9508-9113-011	45		
9441-1583-010	14	9513-9113-008	45		
9441-7083-009	14	9513-9113-009	43		
9441-7083-010	14	9513-9113-012	43		
9441-7583-009	14	9513-9113-013	45		
9441-7583-010	14	9530-1593-009	12		
9443-1563-009	7	9530-1593-010	12		
9443-1563-010	7	9530-9593-009	12		
9443-7563-009	7	9530-9593-010	12		
9443-7563-010	7	9533-9113-001	45		
9453-1083-009	12	9533-9113-002	43		
9453-1083-010	12	9533-9113-003	43		
9453-1583-009	12	9533-9113-004	45		
9453-1583-010	12	9543-1593-009	7		
9453-7083-009	12	9543-1593-010	7		
9453-7083-010	12	9543-9593-009	7		
9453-7583-009	12	9543-9593-010	7		
9453-7583-010	12	9576-9113-001	42		
9454-1513-000	24	9576-9113-002	42		
9454-9513-000	24	9576-9113-003	44		
9455-1113-000	24	9576-9113-004	44		
9455-9113-000	24	9609-1513-000	26		
9456-1113-002	27	9609-9513-000	26		

Numbers ending with -0XX indicate connectors with various types on specified page.



About Applied Engineering Products

Since our foundation in 1973, we have always believed that having our customers take a look "inside AEP" is important in fostering strong vendor/customer relationships. We are proud of our physical plant and equipment, but even more so of our dedicated staff. When customers see first-hand how AEP's people keep a constant focus on maintaining and improving

customer service and satisfaction, the reason for our consistently strong on-time delivery and quality records becomes clear.

We invite you to see for yourself. Call us to arrange a plant tour—or, if you can't make a visit, ask for your copy of *INSIDE AEP*, our facilities and capabilities brochure.



APPLIED ENGINEERING PRODUCTS

(203) 776-2813 • FAX (203) 776-8294

www.aepconnectors.com • aepsales@aepconnectors.com

The SMA connectors in this brochure are only part of our complete line of subminiature and microminiature coaxial connectors and cable assemblies, including:

- SMA
- SMB
- SMC
- SSMB
- SSMC
- SLB (Slide-on version of SMB)
- SSLB (Slide-on version of SSMB)
- 75Ω Snap-on mating
- 75Ω Screw-on mating
- Adapters within and between series
- Flexible cable assemblies
- Semi-rigid cable assemblies
- And over 100 styles of MIL-PRF-39012 QPL connectors in series SMA, SMB, and SMC



Call for your copy of our 184-page full catalog to see them all.



ISO 9001
CERTIFIED



APPLIED ENGINEERING PRODUCTS

104 John W. Murphy Drive • P.O. Box 510 • New Haven, CT 06513

(203) 776-2813 • FAX (203) 776-8294

www.aepconnectors.com • e-mail: aepsales@aepconnectors.com

Mouser Electronics

Authorized Distributor

Click to View Pricing, Inventory, Delivery & Lifecycle Information:

Radial:

[5909-9103-000](#)



Компания «ЭлектроПласт» предлагает заключение долгосрочных отношений при поставках импортных электронных компонентов на взаимовыгодных условиях!

Наши преимущества:

- Оперативные поставки широкого спектра электронных компонентов отечественного и импортного производства напрямую от производителей и с крупнейших мировых складов;
- Поставка более 17-ти миллионов наименований электронных компонентов;
- Поставка сложных, дефицитных, либо снятых с производства позиций;
- Оперативные сроки поставки под заказ (от 5 рабочих дней);
- Экспресс доставка в любую точку России;
- Техническая поддержка проекта, помощь в подборе аналогов, поставка прототипов;
- Система менеджмента качества сертифицирована по Международному стандарту ISO 9001;
- Лицензия ФСБ на осуществление работ с использованием сведений, составляющих государственную тайну;
- Поставка специализированных компонентов (Xilinx, Altera, Analog Devices, Intersil, Interpoint, Microsemi, Aeroflex, Peregrine, Syfer, Eurofarad, Texas Instrument, Miteq, Cobham, E2V, MA-COM, Hittite, Mini-Circuits, General Dynamics и др.);

Помимо этого, одним из направлений компании «ЭлектроПласт» является направление «Источники питания». Мы предлагаем Вам помощь Конструкторского отдела:

- Подбор оптимального решения, техническое обоснование при выборе компонента;
- Подбор аналогов;
- Консультации по применению компонента;
- Поставка образцов и прототипов;
- Техническая поддержка проекта;
- Защита от снятия компонента с производства.



Как с нами связаться

Телефон: 8 (812) 309 58 32 (многоканальный)

Факс: 8 (812) 320-02-42

Электронная почта: org@eplast1.ru

Адрес: 198099, г. Санкт-Петербург, ул. Калинина, дом 2, корпус 4, литера А.