

PROPER USE GUIDELINES

Cumulative Trauma Disorders can result from the prolonged use of manually powered hand tools. Hand tools are intended for occasional use and low volume applications. A wide selection of powered application equipment for extended-use, production operations is available.

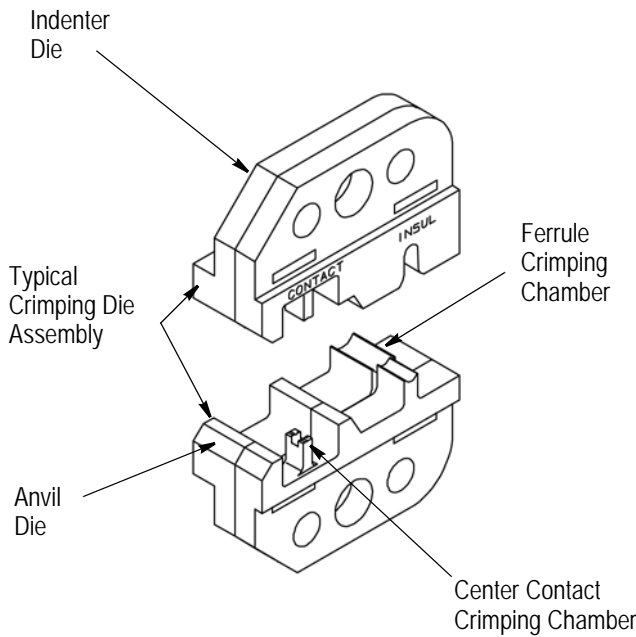

Figure 1

1. INTRODUCTION

SDE (Four-Piece) Crimping Die Assemblies 91912-[] are designed to crimp a variety of connectors when used in PRO-CRIMPER* II Hand Tool Frame Assembly 354940-1. Refer to Figure 5 for a list of connectors and their associated dies, as well as detailed drawings of the crimping dies.

Catalog 1307191 provides a guide for cable- to-connector selection. For connectors not referenced in the catalog, contact TE Product Engineering for recommendations.

Refer to instruction sheet 408-9930 for information concerning PRO-CRIMPER II Hand Tool Frame 354940-1.

NOTE *Dimensions in this document are in metric units [with U.S. customary units in brackets].*

2. DESCRIPTION

Each four-piece crimping die assembly consists of two indenter dies and two anvil dies, which when closed form two or three crimping chambers. The larger crimping chambers crimp the ferrule of the connector onto the coaxial cable. The smaller crimping chamber

crimps the center contact onto the center conductor of the coaxial cable. Each die is held in the PRO-CRIMPER II hand tool jaws by a single screw.

3. DIE INSTALLATION (Figure 1)

1. Close the tool handles until the ratchet releases, then allow the tool handles to open fully.
2. Install anvil die in the movable jaw of the tool frame. Align the die with the retaining screw hole, then secure die with the die-retaining screw. Do NOT fully tighten.
3. Install indenter die in the stationary jaw of the tool frame. Slowly close the tool handles, allowing the dies to align themselves.

NOTE *Once the anvil has entered the indenter, place a copper bus bar (1.57-mm ± 0.05 mm [.062-in. ± .002 in.] diameter) into the center contact crimping chamber of the die assembly.*

4. Close the tool handles completely.
5. Securely tighten both screws with the appropriate screwdriver.

4. CRIMPING PROCEDURE

Select the appropriate cable size and connector. The wire size and insulation diameter must be within the specified range for the connector.

NOTE *This tool is provided with a crimp height adjustment feature. Initially, the crimp height should be verified. Refer to Section 5, Crimp Height Adjustment, to verify crimp height before using the tool.*

For detailed information on cable strip lengths and proper assembly of the connector, refer to the instructions packaged with the connector. Make sure that the connector's ferrule has been placed onto the cable, and that the cable's braided shield is flared away from the cable. Then proceed as follows:

4.1. Crimping the Center Contact (Figure 2)

1. Close the tool handles until the dies are partially closed.
2. Assemble the center contact onto the cable center conductor and place the center contact in the smallest crimping chamber of the anvil die. Make sure the flange on the end of the center contact butts against the die.

Crimping the Center Contact

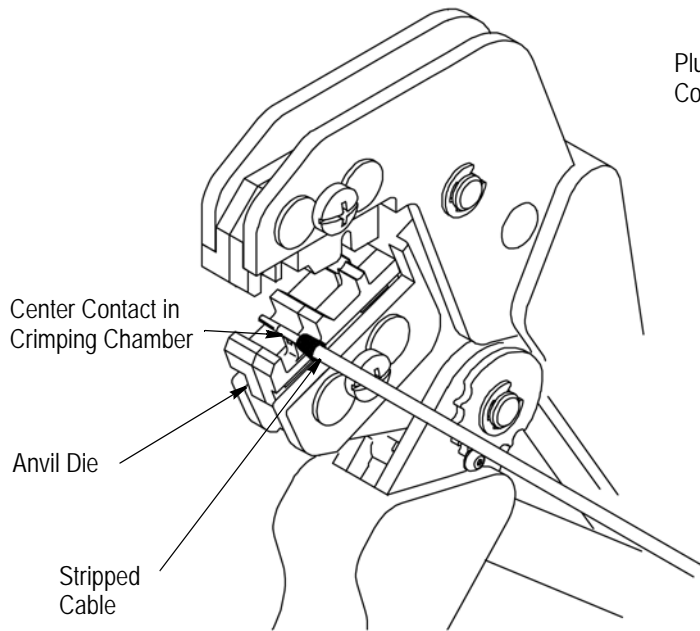

Cross Sectional View

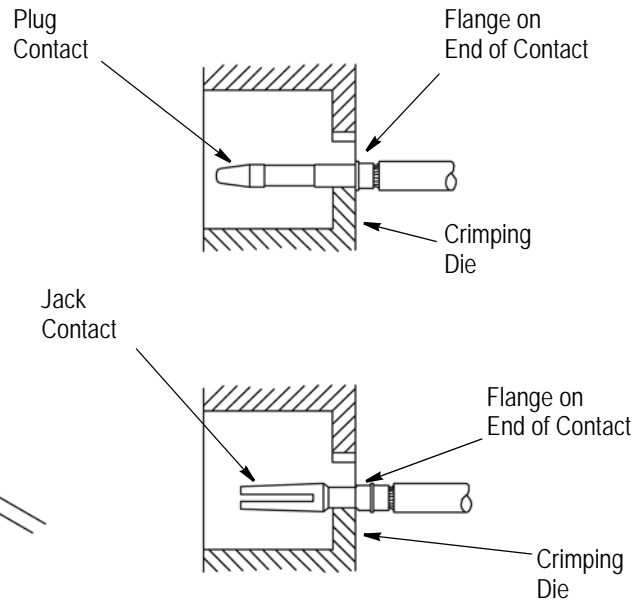

Note: Typical Crimping Dies Shown.

Figure 2

3. Holding the cable in place, close the tool handles until the ratchet releases.

4. Allow the tool handles to open fully and remove the crimped center contact from the dies.



CAUTION Make sure that both sides of the ferrule are started evenly into the crimping chamber. Do not attempt to crimp an improperly positioned ferrule.

5. Carefully close the tool handles until the ratchet releases.

4.2. Crimping the Ferrule (Figure 3)

1. Insert the crimped center contact into the connector body until the cable dielectric butts against the dielectric inside the connector body or until the center contact is securely positioned within the connector. Make sure that the braided shield is over the support sleeve of the connector body and that no strands from the shield enter the connector body.

2. Slide the ferrule up over the braided shield and onto the connector until the ferrule butts against the shoulder on the connector body.

3. Place the ferrule in the appropriate crimping chamber of the anvil die so that the shoulder on the connector body butts against the edge of the die.

NOTE



Refer to the instruction sheet packaged with the connector to determine the appropriate crimping chamber for the ferrule.

4. While holding the assembly together, begin to close the tool handles. Keep holding the assembly until the dies have closed enough to clamp the assembly in place.

Crimping the Ferrule

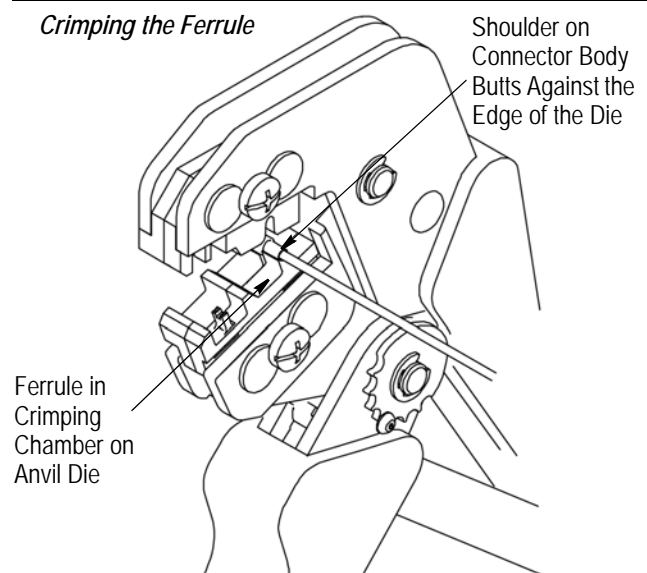

Note: Typical Crimping Dies Shown.

Figure 3

6. Allow the tool handles to open fully and remove the crimped connector from the dies.

5. CRIMP HEIGHT ADJUSTMENT

The tool frame assembly ratchet mechanism features an adjustment wheel with numbered settings. If the crimp height is not acceptable, adjust the ratchet as follows:

1. Remove the lockscrew from the ratchet adjustment wheel.
2. With a screwdriver, adjust the ratchet wheel from the opposite side of the tool.
3. Observe the ratchet adjustment wheel. If a tighter crimp is required, rotate the adjustment wheel COUNTERCLOCKWISE to a higher-numbered setting. If a looser crimp is required, rotate the adjustment wheel CLOCKWISE to a lower-numbered setting.
4. Replace the lockscrew.
5. Make a sample crimp and measure the crimp height. If the crimp height is acceptable, secure the lockscrew. If the dimension is unacceptable, remove lockscrew and continue to adjust the ratchet, and again measure a sample crimp.

6. MAINTENANCE AND INSPECTION

6.1. Maintenance

1. Remove dust, moisture, and other contaminants with a clean, soft brush, or a clean, soft, lint-free cloth. Do NOT use any objects that could damage the dies or tool.
2. Make sure that the proper die-retaining screws are properly secured.
3. When the dies are not in use, store them in a clean, dry area.
4. Store the tool with the tool handles closed to prevent objects from becoming lodged within the jaws.

6.2. Inspection

1. Remove all lubrication and accumulated film from the dies by immersing the dies in a suitable commercial degreaser.
2. Make certain that all die-retaining screws and die components are properly secured.
3. Inspect the crimping surfaces for flattened, chipped, worn, or cracked areas. If damage is evident, the dies must be replaced. Refer to Section 7, REPLACEMENT.

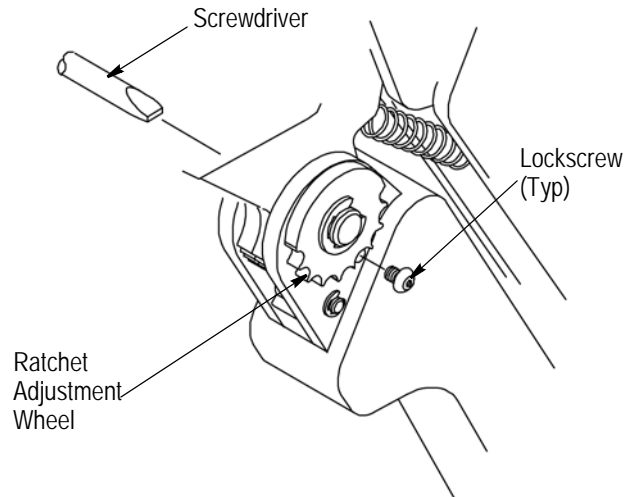

Figure 4

6.3. Measuring the Die Opening

The die assembly will perform correctly as long as: (1) the product specified is correct for the application, (2) the specific die assembly is used, (3) the die assembly has been measured to ensure that the openings are correct, and (4) the tool has been adjusted correctly. Figure 5 provides information on die opening sizes.

7. REPLACEMENT

These crimping die assemblies are inspected before shipment. It is recommended that the dies be inspected immediately upon arrival at your facility to ensure that the dies have not been damaged during shipment.

Order replacements through your local TE representative, or call 1-800-526-5142, or send a facsimile of your purchase order to 1-717-986-7605, or write to:

CUSTOMER SERVICE (038-035)
 TYCO ELECTRONICS CORPORATION
 PO BOX 3608
 HARRISBURG PA 17105-3608

8. REVISION SUMMARY

Revisions to this instruction sheet include:

- Changed company name and logo

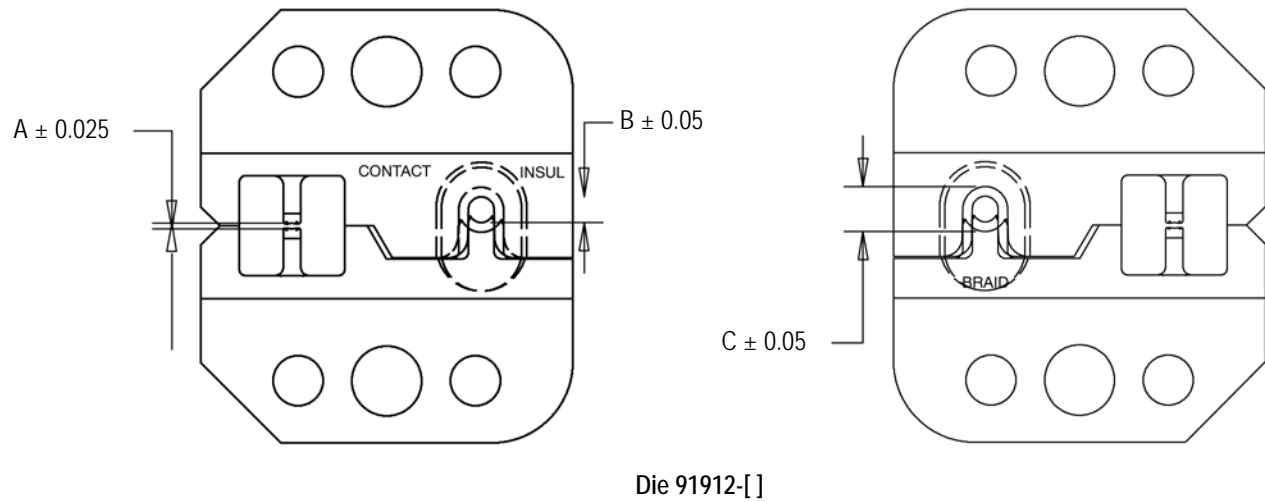

Note: Dimensions listed above are in metric units.

| PART NUMBER | PRODUCT DESCRIPTION | DIE CLOSURE DIMENSIONS (MM [IN.]) | | |
|-------------|--|-----------------------------------|--------------|-------------|
| | | A | B | C |
| 91912-1 | Miniature Threaded COAXICON Connectors | 0.472 [.0186] | 2.030 [.079] | 3.53 [.139] |
| 91912-2 | Miniature Threaded COAXICON Connectors | 0.472 [.0186] | 2.340 [.092] | 3.53 [.139] |
| 91912-3 | Miniature COAXICON Connectors | 0.965 [.038] | 2.900 [.114] | 3.61 [.142] |
| 91912-4 | Miniature COAXICON Connectors | 0.965 [.038] | 2.870 [.113] | 3.53 [.139] |
| 91912-5 | Miniature COAXICON Connectors | 0.965 [.038] | 6.81 [.268] | 5.16 [.203] |

Figure 5



Компания «ЭлектроПласт» предлагает заключение долгосрочных отношений при поставках импортных электронных компонентов на взаимовыгодных условиях!

Наши преимущества:

- Оперативные поставки широкого спектра электронных компонентов отечественного и импортного производства напрямую от производителей и с крупнейших мировых складов;
- Поставка более 17-ти миллионов наименований электронных компонентов;
- Поставка сложных, дефицитных, либо снятых с производства позиций;
- Оперативные сроки поставки под заказ (от 5 рабочих дней);
- Экспресс доставка в любую точку России;
- Техническая поддержка проекта, помощь в подборе аналогов, поставка прототипов;
- Система менеджмента качества сертифицирована по Международному стандарту ISO 9001;
- Лицензия ФСБ на осуществление работ с использованием сведений, составляющих государственную тайну;
- Поставка специализированных компонентов (Xilinx, Altera, Analog Devices, Intersil, Interpoint, Microsemi, Aeroflex, Peregrine, Syfer, Eurofarad, Texas Instrument, Miteq, Cobham, E2V, MA-COM, Hittite, Mini-Circuits, General Dynamics и др.);

Помимо этого, одним из направлений компании «ЭлектроПласт» является направление «Источники питания». Мы предлагаем Вам помощь Конструкторского отдела:

- Подбор оптимального решения, техническое обоснование при выборе компонента;
- Подбор аналогов;
- Консультации по применению компонента;
- Поставка образцов и прототипов;
- Техническая поддержка проекта;
- Защита от снятия компонента с производства.



Как с нами связаться

Телефон: 8 (812) 309 58 32 (многоканальный)

Факс: 8 (812) 320-02-42

Электронная почта: org@eplast1.ru

Адрес: 198099, г. Санкт-Петербург, ул. Калинина, дом 2, корпус 4, литера А.