

COAXICON Contacts

Product Facts

- Tyco Electronics provides a variety of contacts for coaxial connectors
- Contacts are available in a range of sizes that may be used with the various types of coaxial cable on the market
- COAXICON contacts are of the crimp, snap-in type and are available in the following designs: Miniature Contacts, Subminiature Contacts and Size 8 Contacts

Miniature Contacts are designed for high density multiple circuit connector applications. A wide range of cable sizes is accommodated by using three sizes of outer shell termination ends and three sizes of contacts.

Subminiature Contacts are used in high density applications and are ideal for mixing coaxial and other styles of pin and socket contacts in the same connector housing.

Size 8 Contacts are compatible with industry standard size 8 connectors such as Subminiature D and AMP-HDI connector housings. Straight and right-angle styles, as well as pc board versions for AMP-HDI connectors are available.



Miniature Contacts

Performance Characteristics

Insulation Resistance — 5000 megohms min

Dielectric Withstanding Voltage — 1,000 volts rms for 1 minute

Contact Resistance — 2.0 milliohms @ 1 ampere

Low-Level Conductivity — 10 milli-volts DC min.

VSWR — 1.3 to 1.0 @ 1,000 MHz max.

Cable Retention —

RG/U Cable	Retention lbs [N]
58C	50 [222]
188A	30 [133]
180B	28 [125]
195A	16 [71]

Durability — 500 cycles @ 10 cycles per minute max.

Vibration — 2 hrs. per MIL-STD-202, Method 201

Shock — 50 G's per MIL-Std-202, Method 213, Cond. G

Temperature Cycling — 5 cycles per MIL-STD-202, Method 102, Cond C.

Temperature Range — -55°C to +125°C

Test Method for Electronic and Electrical Component Parts — MIL-STD-202

Material

Outer Shell — Brass per MIL-C-50

Center Conductor — Brass per QQ-B-626, or Beryllium copper per QQ-C-533

Note:

A ferrule and retention spring (201142-2) are required for each pin and socket.

Extraction Tool No. 305183-8

Inner Dielectric — Polypropylene, nylon, or polymethylpentene, general purpose

Retention Spring — Stainless steel per QQ-S-766

Ferrule — Copper per QQ-C-576

Finish

Outer Shell, Center Conductor — 0.00076 [.000030] gold over 0.00076 [.000030] nickel

Retention Spring — Nickel per QQ-N-290

Ferrule — Bright tin per MIL-T-10727

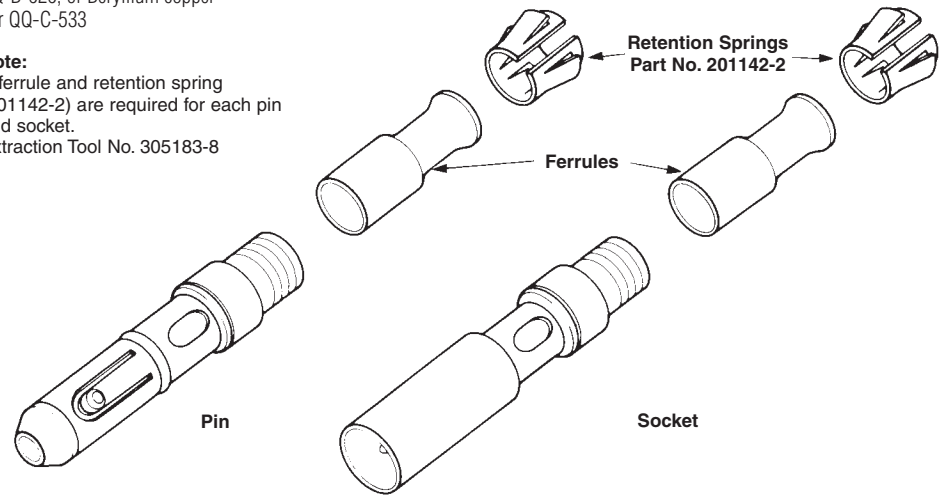

RG/U Cable	Ferrule No.	Integral Die Hand Tool	PRO-CRIMPER	Die Insert for Tools: Hand Tool 69710-1 Pneu. 69365-2, 69365-3 ²	Part Numbers	
					Pin	Socket
316, 188, 188A 174	328666	—	—	69227-2	201143-5	201144-5
179, 179A, 179B 161, 187, 187A Belden 9221	328666	—	—	69227-2	201143-1	201144-1
188 Double Braid 316 Double Braid	221848-3	58290-1	—	69227-2	201143-5	201144-5
122	328664	45639-2	91912-3	69222-2	201145-1	—
180, 180A, 180B 195, 195A, 21-597	328664	45639-2	91912-3	69222-2	201145-2	201146-2
Belden 8218	328664	45639-2	91912-3	69222-2	201145-2	201146-2
58, 58A, 58B, 58C	328663	45740-2	—	69220-2	201145-4	201146-4
141 55, 55A, 55B, 223	330478	69248-4	—	69315-4	201145-4	201146-4
124, 140, 210 62, 62A, 62B 59, 59A, 59B	329006	—	—	69675-1	201097-1*	201098-1*
Twisted Pair						
24-22 AWG [0.2-0.4 mm ²] (Stranded) ¹	328666	91912-4	—	69672	201143-5	201144-5
Shielded Wire 22, NAS-702, Class B	328663	45740-2	—	69220-2	201145-4	201146-4
Brand Rex T5788A 26 AWG [0.12-0.155 mm ²] ³	328664	45639-2	91912-3	69222-2	201145-2	201146-2

*These contacts are for use in the 4-position G Series connector modules only.

¹Maximum insulation diameter—**2.92** [.115] (two wires combined).

²Includes bench mount and foot control; requires Manual Take-Up Attachment No. 69689.

³Dielectric O.D.—**2.69** [.106] max.; Cable O.D.—**4.06** [.160].

Note: Part Numbers are RoHS compliant except: ♦ Indicates non-RoHS compliant.

Miniature PC Board Sockets

Material

Shell and Center Contact — Brass per MIL-C-50 and QQ-B-626

Dielectric — Polypropylene, or Polymethylpentene, general purpose

Finish

Center Contact — 0.00076 [.000030] gold over copper

Shell — Gold plated per MIL-G-45204

Performance Characteristics

Dielectric Withstanding Voltage — 1,000 volts, rms

Impedance — Non-constant

Operating Temperature Range — -55°C to +85°C

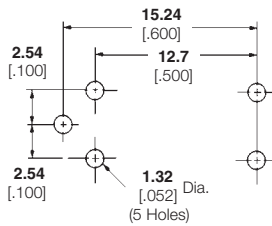
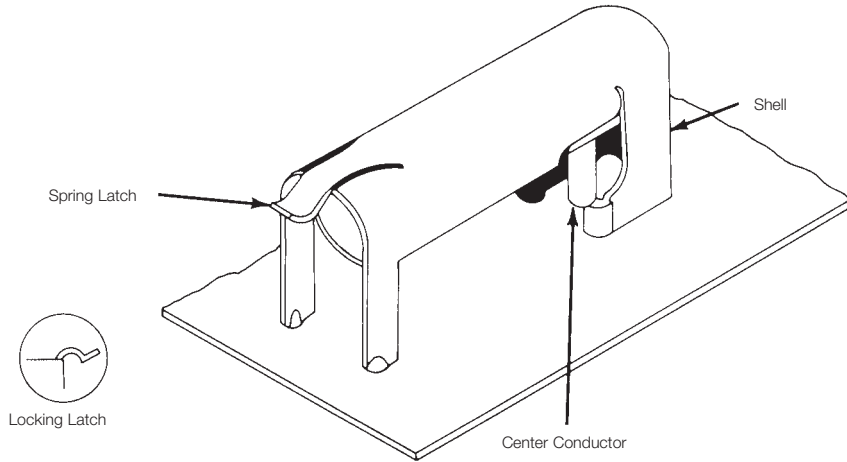

Recommended Mounting Hole Layout

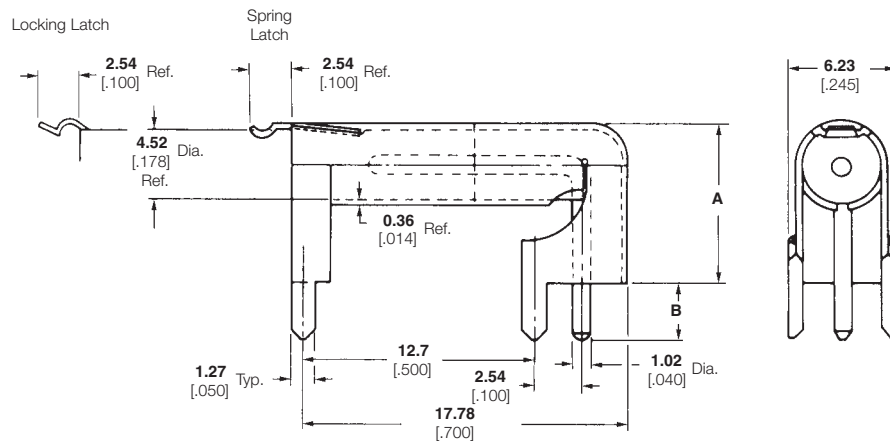

Type	PC Board Thickness	Retention		Dimensions		Part No.
		lb.	[N]	A	B	
Spring Latch	1.57 .062	1.25	5.56	9.07 .357	3.18 .125	50084-1
Spring Latch	3.18 .125	1.25	5.56	7.49 .295	4.75 .187	50095-1
Locking Latch	3.18 .125	7	31.1	7.49 .295	4.75 .187	50105-1
Locking Latch	1.57 .062	7	31.1	9.07 .357	3.18 .125	50107-1

Note: For mateable Miniature Contacts, see page 245.

Note: Part Numbers are RoHS compliant except: ♦ Indicates non-RoHS compliant.

Subminiature PC Board Sockets

Material

Shell and Center Contact — Brass per MIL-C-50 and QQ-B-626

Dielectric — Polypropylene, or polymethylpentene, general purpose

Finish

Center Contact — 0.00076[.000030] gold per MIL-G-45204 over copper per MIL-C-14550

Shell — Gold

Performance Characteristics

Dielectric Withstanding Voltage — 600 volts, rms

Operating Temperature Range — -55°C to +85°C

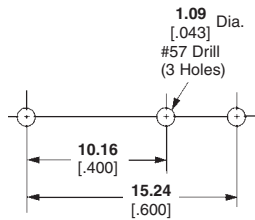
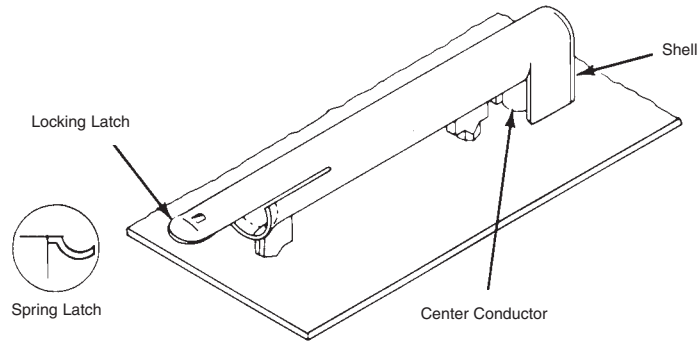

**Recommended
Mounting Hole Layout**

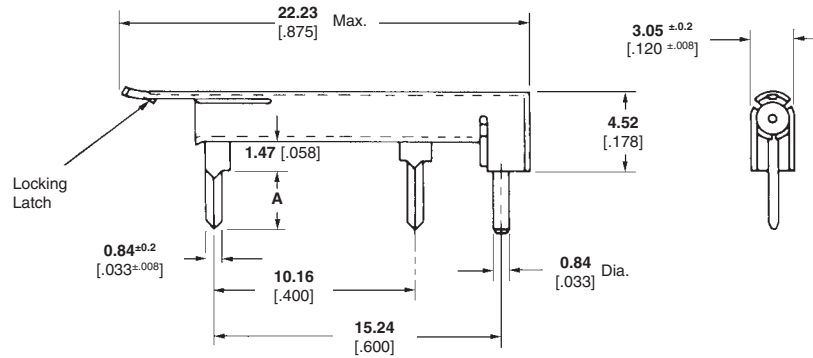

Type	PC Board Thickness	Dim. L	Part No.
Spring Latch	1.57 .062	2.54 .100	226023-1
Locking Latch	1.57 .062	2.54 .100	226060-1

Mating Subminiature COAXICON Pins

These short Subminiature COAXICON Pins are recommended for use with any of the sockets listed above.

Note: Alignment springs are not required for this application and are not included with the pin assemblies.



RG/U Cable	Ferrule No.	Integral Die Hand Tool	Die Insert for Tools: Hand Tool 69710-1 Pneu. 69365-2, 69365-3	Part No.
174 316, 188, 188A	1-332056-0	91911-3	69690	51563-8
179, 179A, 179B 187, 187A	1-332056-0	91911-4	69690-1	51563-8
161	1-332056-0	69656-5	—	51563-8

Note: Part Numbers are RoHS compliant except: ♦ Indicates non-RoHS compliant.

Subminiature Contacts

Material

Outer Shell — Brass per MIL-C-50

Center Conductor — Beryllium copper per QQ-C-533 (Pin); Brass per QQ-B-626 (Socket)

Inner Dielectric — Polypropylene, nylon, or polymethylpentene, general purpose

Retention Spring — Stainless steel per QQ-S-766

Ferrule — Copper per QQ-C-576

Finish

Outer Shell and Socket

Center Conductor — 0.00076 [.000030] gold over 0.00127 [.000050] nickel

Pin Center Conductor — 0.00076 [.000030] gold over 0.00254 [.000100] copper

Ferrule — Bright tin per MIL-T-10727

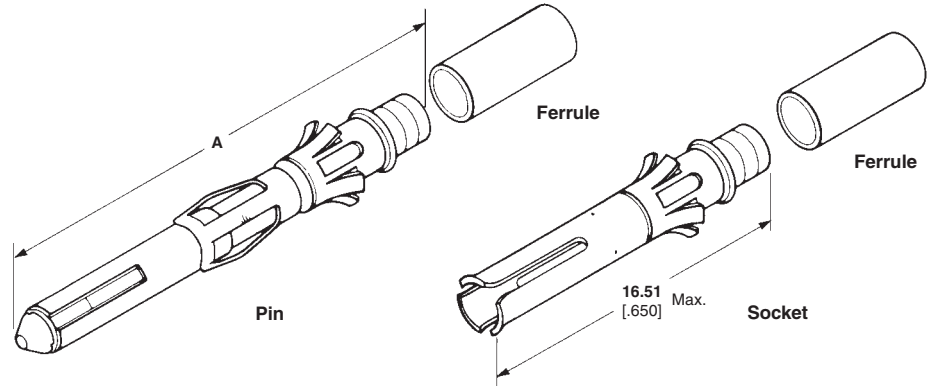

A = Multimate Pin **25.65** [1.010]
Short Pin **22.66** [.892]

Selection Chart for Coaxial Cable

RG/U Cable	Integral Die Hand Tool	PRO-CRIMPER	Die Insert for Tools: Hand Tool 69710-1 Pneu. Tool 69365-2, 69365-3*	Contact Part Numbers			
				Multimate Pin	Short Pin	Socket	Ferrule
178, 178A, 178B 196, 196A	69656-2	—	69690-2	226537-2	—	51565-2	1-332057-0
196 (Double Braid)	69656-9	—	—	226537-2	—	51565-2	225088-1
174, 316 188, 188A	—	91911-3	69690	226537-1	—	51565-1	1-332056-0
179, 179A, 179B 187, 187A Belden 9221	—	91911-4	69690-1	226537-1	—	51565-1	1-332056-0
RD-316	69656-7	—	—	226537-1	—	51565-1	225088-3
187 (Double Braid)	69656-8	—	—	226537-1	—	51565-1	225088-1
161	69656-5	—	—	226537-1	—	51565-1	1-332056-0

Selection Chart for Twisted Pairs and Shielded Wire

Wire Size AWG	[mm ²]	Integral Die Hand Tool	PRO-CRIMPER	Die Insert for Tools: Hand Tool 69710-1 Pneu. Tool 69365-2, 69365-3*	Contact Part Numbers			
					Multimate Pin	Short Pin	Socket	Ferrule
30 (Twisted Pair, Solid)	0.05	69656-2	—	69690-2	226537-3	51563-3	51565-3	1-332057-0
28 (Twisted Pair, Solid)	0.08-0.09	—	91911-3	69690	226537-3	51563-3	51565-3	1-332057-0
28 (Twisted Pair, Stranded; 7 str., .005 [0.13] Dia.)	0.08-0.09	—	91911-4	69690-1 or 69690-2	226537-3	51563-3	51565-3	1-332057-0
26 (Twisted Pair, Solid or Stranded; 7 str., .0063 [0.16] Dia.)	0.12-0.15	—	91911-3	69690	226537-3	51563-3	51565-3	1-332057-0
26 (Shielded, 0.75 [1.91] Max. O.D.)	0.12-0.15	69656-3	—	69690-3	226537-1	—	51565-1	1-332057-0

*Includes bench mount and foot control.

Extraction Tool 305183

Note: A ferrule is required for each pin and socket.

Note: Part Numbers are RoHS compliant except: ♦ Indicates non-RoHS compliant.



Компания «ЭлектроПласт» предлагает заключение долгосрочных отношений при поставках импортных электронных компонентов на взаимовыгодных условиях!

Наши преимущества:

- Оперативные поставки широкого спектра электронных компонентов отечественного и импортного производства напрямую от производителей и с крупнейших мировых складов;
- Поставка более 17-ти миллионов наименований электронных компонентов;
- Поставка сложных, дефицитных, либо снятых с производства позиций;
- Оперативные сроки поставки под заказ (от 5 рабочих дней);
- Экспресс доставка в любую точку России;
- Техническая поддержка проекта, помощь в подборе аналогов, поставка прототипов;
- Система менеджмента качества сертифицирована по Международному стандарту ISO 9001;
- Лицензия ФСБ на осуществление работ с использованием сведений, составляющих государственную тайну;
- Поставка специализированных компонентов (Xilinx, Altera, Analog Devices, Intersil, Interpoint, Microsemi, Aeroflex, Peregrine, Syfer, Eurofarad, Texas Instrument, Miteq, Cobham, E2V, MA-COM, Hittite, Mini-Circuits, General Dynamics и др.);

Помимо этого, одним из направлений компании «ЭлектроПласт» является направление «Источники питания». Мы предлагаем Вам помощь Конструкторского отдела:

- Подбор оптимального решения, техническое обоснование при выборе компонента;
- Подбор аналогов;
- Консультации по применению компонента;
- Поставка образцов и прототипов;
- Техническая поддержка проекта;
- Защита от снятия компонента с производства.



Как с нами связаться

Телефон: 8 (812) 309 58 32 (многоканальный)

Факс: 8 (812) 320-02-42

Электронная почта: org@eplast1.ru

Адрес: 198099, г. Санкт-Петербург, ул. Калинина, дом 2, корпус 4, литера А.