

## Product Specification

### 6.1 Gb/s Short-Wavelength SFP+ Transceiver

#### FTLF8526W4BTL

#### PRODUCT FEATURES

- Up to 8G Gb/s bi-directional data links
- Hot-pluggable SFP+ footprint
- Built-in digital diagnostic functions
- 850nm Oxide VCSEL laser transmitter
- Duplex LC connector
- RoHS compliant and Lead Free
- 300m on high-bandwidth 50/125um (OM3) MMF
- Metal enclosure, for lower EMI
- Single 3.3V power supply
- < 0.5W power dissipation
- Extended operating temperature range: -40°C to 85°C



#### APPLICATIONS

- Wireless – CPRI, OBSAI, LTE

Finisar's FTLF8526W4BTL SFP+ transceivers are designed for use in wireless application of links up to 6.1 Gb/s data rates over multimode fiber. The optical transceiver is compliant per the RoHS Directive 2011/65/EU. See Finisar Application Note AN-2038 for more details.

#### PRODUCT SELECTION

**FTLF8526W4BTL**

## 4. Pin Descriptions

Pin	Symbol	Name/Description	Ref.
1	V <sub>EET</sub>	Transmitter Ground (Common with Receiver Ground)	1
2	T <sub>FAULT</sub>	Transmitter Fault.	2
3	T <sub>DIS</sub>	Transmitter Disable. Laser output disabled on high or open.	3
4	SDA	2-wire Serial Interface Data Line (MOD-DEF2)	4
5	SCA	2-wire Serial Interface Clock (MOD-DEF1)	4
6	MOD_ABS	Module Absent, connected to V <sub>EET</sub> or V <sub>EER</sub>	4
7	RS0	NC	
8	LOS	Loss of Signal indication. Logic 0 indicates normal operation.	5
9	RS1	NC	
10	V <sub>EER</sub>	Receiver Ground (Common with Transmitter Ground)	1
11	V <sub>EER</sub>	Receiver Ground (Common with Transmitter Ground)	1
12	RD-	Receiver Inverted DATA out. AC Coupled	
13	RD+	Receiver Non-inverted DATA out. AC Coupled	
14	V <sub>EER</sub>	Receiver Ground (Common with Transmitter Ground)	1
15	V <sub>CCR</sub>	Receiver Power Supply	
16	V <sub>CCT</sub>	Transmitter Power Supply	
17	V <sub>EET</sub>	Transmitter Ground (Common with Receiver Ground)	1
18	TD+	Transmitter Non-Inverted DATA in. AC Coupled.	
19	TD-	Transmitter Inverted DATA in. AC Coupled.	
20	V <sub>EET</sub>	Transmitter Ground (Common with Receiver Ground)	1

Notes:

1. Circuit ground is internally isolated from chassis ground.
2. T<sub>FAULT</sub> is an open collector/drain output, which should be pulled up with a 4.7k – 10k Ohms resistor on the host board if intended for use. Pull up voltage should be between 2.0V to V<sub>cc</sub> + 0.3V. A high output indicates a transmitter fault caused by either the TX bias current or the TX output power exceeding the preset alarm thresholds. A low output indicates normal operation. In the low state, the output is pulled to <0.8V.
3. Laser output disabled on T<sub>DIS</sub> >2.0V or open, enabled on T<sub>DIS</sub> <0.8V.
4. Should be pulled up with 4.7k – 10kohms on host board to a voltage between 2.0V and 3.6V. MOD\_ABS pulls line low to indicate module is plugged in.
5. LOS is open collector output. Should be pulled up with 4.7k – 10kohms on host board to a voltage between 2.0V and 3.6V. Logic 0 indicates normal operation; logic 1 indicates loss of signal.

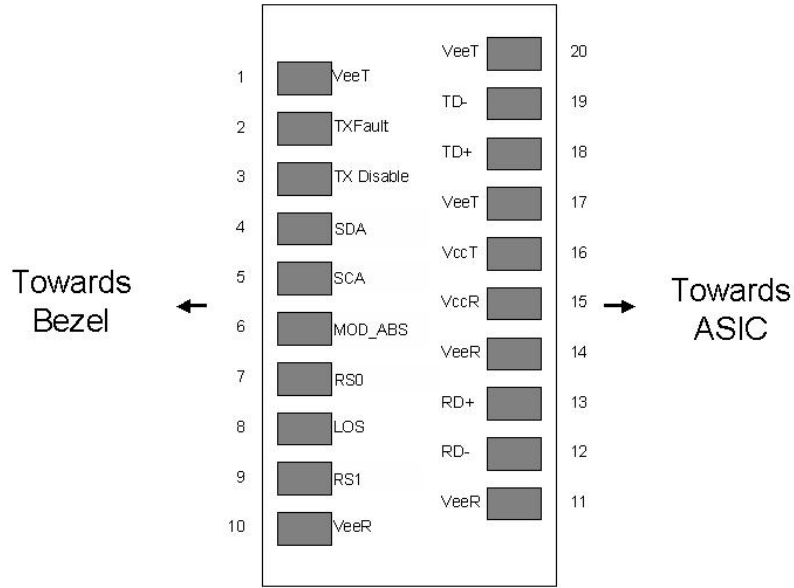

Diagram of Host Board Connector Block Pin Numbers and Names

4. Absolute Maximum Ratings

Parameter	Symbol	Min	Typ	Max	Unit	Ref.
Maximum Supply Voltage	Vcc	-0.5		4.0	V	
Storage Temperature	T <sub>S</sub>	-40		85	°C	
Case Operating Temperature	T <sub>A</sub>	-40		85	°C	
Relative Humidity (Non-condensing)	RH	0		85	%	

**III. Electrical Characteristics ( $T_A$ ,  $V_{CC} = 3.15$  to  $3.46$  Volts)**

Parameter	Symbol	Min	Typ	Max	Unit	Ref.
Supply Voltage	$V_{CC}$	3.15		3.45	V	
Supply Current	$I_{CC}$			180	mA	
<b>Transmitter</b>						
Input differential impedance	$R_{in}$		100		$\Omega$	1
Single ended data input swing	$V_{in,pp}$	90		800	mV	
Transmit Disable Voltage	$V_D$	2		$V_{CC}$	V	2
Transmit Enable Voltage	$V_{EN}$	Vee		Vee+ 0.8	V	
<b>Receiver</b>						
Single ended data output swing	$V_{out,pp}$	185		425	mV	3
Data Output Rise/Fall Time @ 6.1 Gb/s	$t_r / t_f$			80	ps	4
LOS Fault	$V_{LOS\ fault}$	2		$V_{CC_{HOST}}$	V	5
LOS Normal	$V_{LOS\ norm}$	Vee		Vee+0.8	V	5
Power Supply Rejection	PSR	100			mVpp	6
Deterministic Jitter @ 6.1 Gb/s	RX DJ			70	ps	
Total Jitter @ 6.1 Gb/s	RX TJ			116	ps	

Notes:

1. Connected directly to TX data input pins. AC coupling from pins into laser driver IC.
2. Or open circuit.
3. Into 100 ohms differential termination.
4. Unfiltered, 20 – 80 %
5. LOS is an open collector output. Should be pulled up with 4.7k – 10kohms on the host board. Normal operation is logic 0; loss of signal is logic 1. Maximum pull-up voltage is 5.5V.
6. Receiver sensitivity is compliant with power supply sinusoidal modulation of 20 Hz to 1.5 MHz up to specified value applied through the recommended power supply filtering network.

VI. **Optical Characteristics** ( $T_A$ ,  $V_{CC} = 3.15$  to  $3.46$  Volts)

Parameter	Symbol	Min	Typ	Max	Unit	Ref.
<b>Transmitter</b>						
Output Opt. Pwr: 50 or 62.5 MMF	$P_{OUT}$	-8.2			dBm	1
Optical Wavelength	$\lambda$	840		860	nm	
Spectral Width	$\sigma$			0.65	nm	
Optical Modulation Amplitude	OMA	302			$\mu$ W	
Optical Rise/Fall Time	$t_r/ t_f$			90	ps	2
Relative Intensity Noise	RIN			-128	dB/Hz	
<b>Receiver</b>						
Receiver OMA Sensitivity	$R_{XSENS}$			76	$\mu$ W	
Average Receiver Power	$R_{XMAX}$	0			dBm	
Optical Center Wavelength	$\lambda_C$	770		860	nm	
Optical Return Loss		12			dB	
LOS De-Assert	$LOS_D$			-18	dBm	
LOS Assert	$LOS_A$	-30			dBm	
LOS Hysteresis		0.5			dB	

Notes:

1. Class 1 Laser Safety per FDA/CDRH, and EN (IEC) 60825 laser safety standards.
2. Unfiltered, 20-80%. Complies with FC 1x and 2x eye mask when filtered.

## VI. General Specifications

Parameter	Symbol	Min	Typ	Max	Units	Ref.
Data Rate	BR		6.1		Gb/sec	
Bit Error Rate	BER			$10^{-12}$		1
Fiber Length on 50/125 $\mu$ m high-bandwidth (OM3) MMF	L			300	m	

### Notes:

1. PRBS 2<sup>7</sup>-1.

## VI. Environmental Specifications

Parameter	Symbol	Min	Typ	Max	Units	Ref.
Case Operating Temperature	T <sub>op</sub>	-40		85	°C	
Storage Temperature	T <sub>sto</sub>	-40		85	°C	

## VII. Regulatory Compliance

Finisar transceivers are Class Finisar laser transceiver complies with Laser Class 1 per latest edition of EN60825-1 and IEC 60825-1 for fiber optic systems.

## VIII. Digital Diagnostic Functions

Finisar FTLF8526W4BTL SFP+ transceivers support the 2-wire serial communication protocol as defined in the SFP MSA<sup>c</sup>. It is very closely related to the E<sup>2</sup>PROM defined in the GBIC standard, with the same electrical specifications.

The standard SFP serial ID provides access to identification information that describes the transceiver's capabilities, standard interfaces, manufacturer, and other information.

Additionally, Finisar SFP transceivers provide an enhanced digital diagnostic monitoring interface, which allows real-time access to device operating parameters such as transceiver temperature, laser bias current, transmitted optical power, received optical power and transceiver supply voltage. It also defines a sophisticated system of alarm and warning flags, which alerts end-users when particular operating parameters are outside of a factory set normal range.

The SFP MSA defines a 256-byte memory map in E<sup>2</sup>PROM that is accessible over a 2-wire serial interface at the 8 bit address 1010000X (A0h). The digital diagnostic monitoring interface makes use of the 8 bit address 1010001X (A2h), so the originally defined serial ID memory map remains unchanged. The interface is identical to, and is thus fully backward compatible with both the GBIC Specification and the SFP Multi Source Agreement. The complete interface is described in Finisar Application Note AN-2030: "Digital Diagnostics Monitoring Interface for SFP Optical Transceivers".

The operating and diagnostics information is monitored and reported by a Digital Diagnostics Transceiver Controller (DDTC) inside the transceiver, which is accessed through a 2-wire serial interface. When the serial protocol is activated, the serial clock signal (SCL, Mod Def 1) is generated by the host. The positive edge clocks data into the SFP transceiver into those segments of the E<sup>2</sup>PROM that are not write-protected. The negative edge clocks data from the SFP transceiver. The serial data signal (SDA, Mod Def 2) is bi-directional for serial data transfer. The host uses SDA in conjunction with SCL to mark the start and end of serial protocol activation. The memories are organized as a series of 8-bit data words that can be addressed individually or sequentially.

For more information, please see the SFP MSA documentation<sup>b,e</sup> and Finisar Application Note AN-2030.

Please note that evaluation board FDB-1027 is available with Finisar ModDEMO software that allows simple to use communication over the 2-wire serial interface.

## IX. Digital Diagnostic Specifications

FTLF8526W4BTL transceivers can be used in host systems that require either internally or externally calibrated digital diagnostics.

Parameter	Symbol	Units	Min	Max	Accuracy	Ref.
Transceiver temperature	D <sub>DDTemp</sub>	°C	-40	+85	±5°C	
Transceiver supply voltage	D <sub>DDVoltage</sub>	V	3.14	3.45	±3%	
Transmitter bias current	D <sub>DDBias</sub>	mA	0	50	±10%	1
Transmitter output power	D <sub>DDTx-Power</sub>	dBm	-9	+2.4	±3dB	
Receiver average optical input power	D <sub>DDRx-Power</sub>	dBm	-11	+2.4	±3dB	

### Notes:

1. Accuracy of Measured Tx Bias Current is 10% of the actual Bias Current from the laser driver to the Measured Tx Bias Current is 10% of the actual Bias Current from the laser driver to the laser.



**X. Mechanical Specifications**

Finisar’s FTLF8526W4BTL SFP+ transceivers are compatible with the SFF-8432<sup>a</sup> specification for improved pluggable form factor.

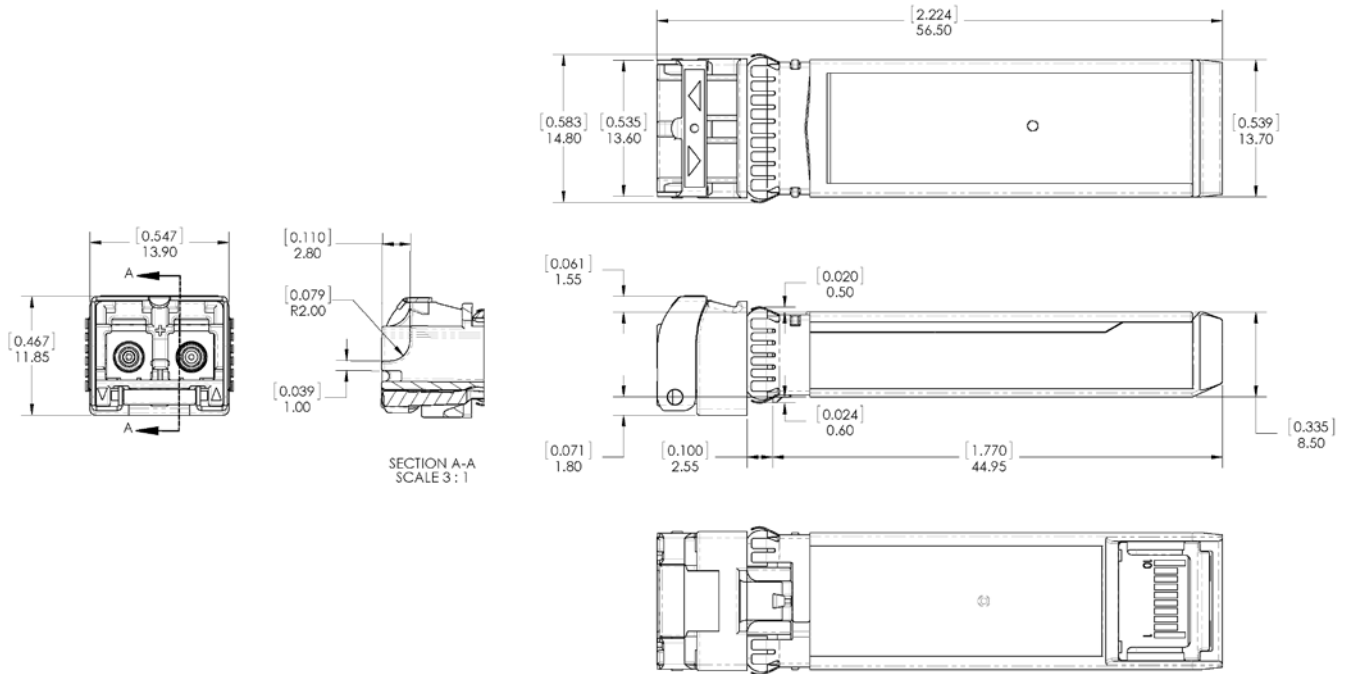

**FTLF8526W4BTL**

# XI. PCB Layout and Bezel Recommendations

- △ Datum and Basic Dimension Established by Customer
- △ Pads and Vias are Chassis Ground, 11 Places
- △ Through Holes are Unplated

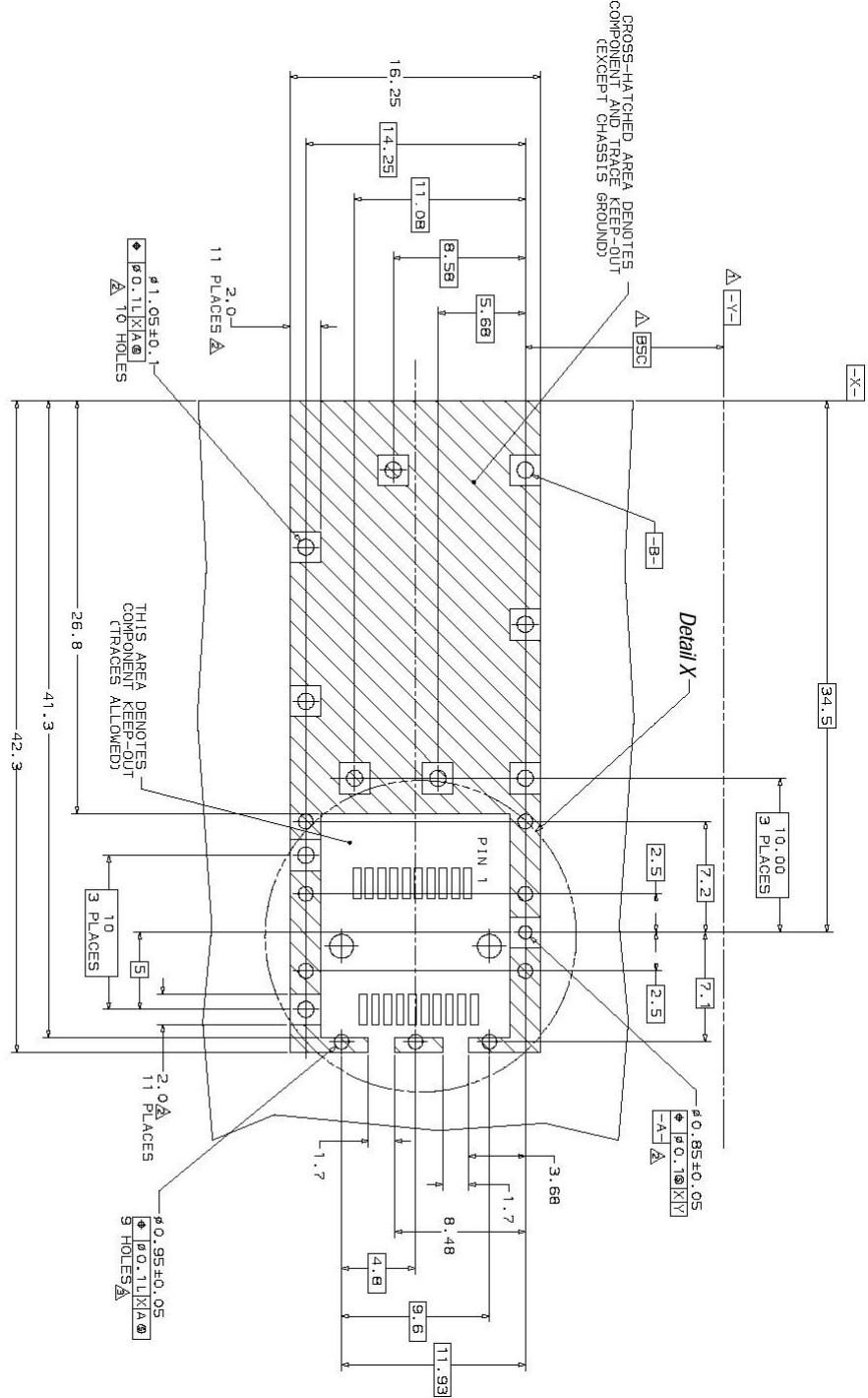

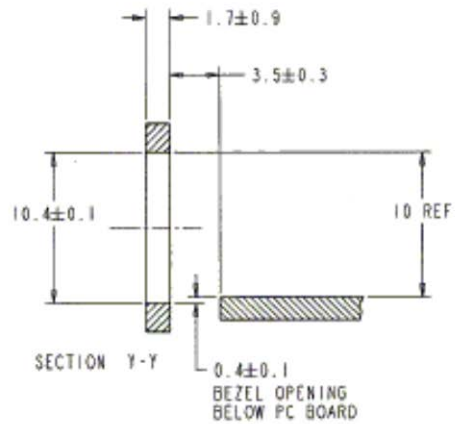
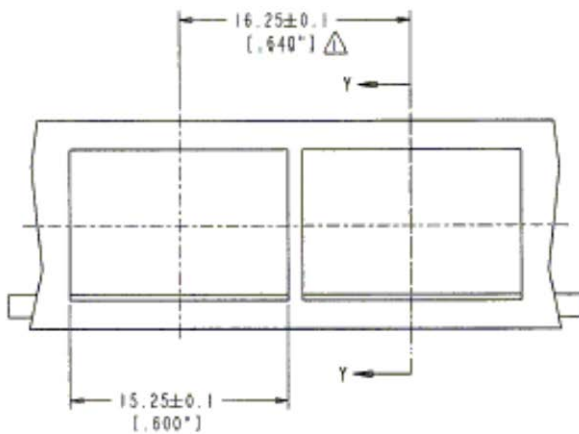
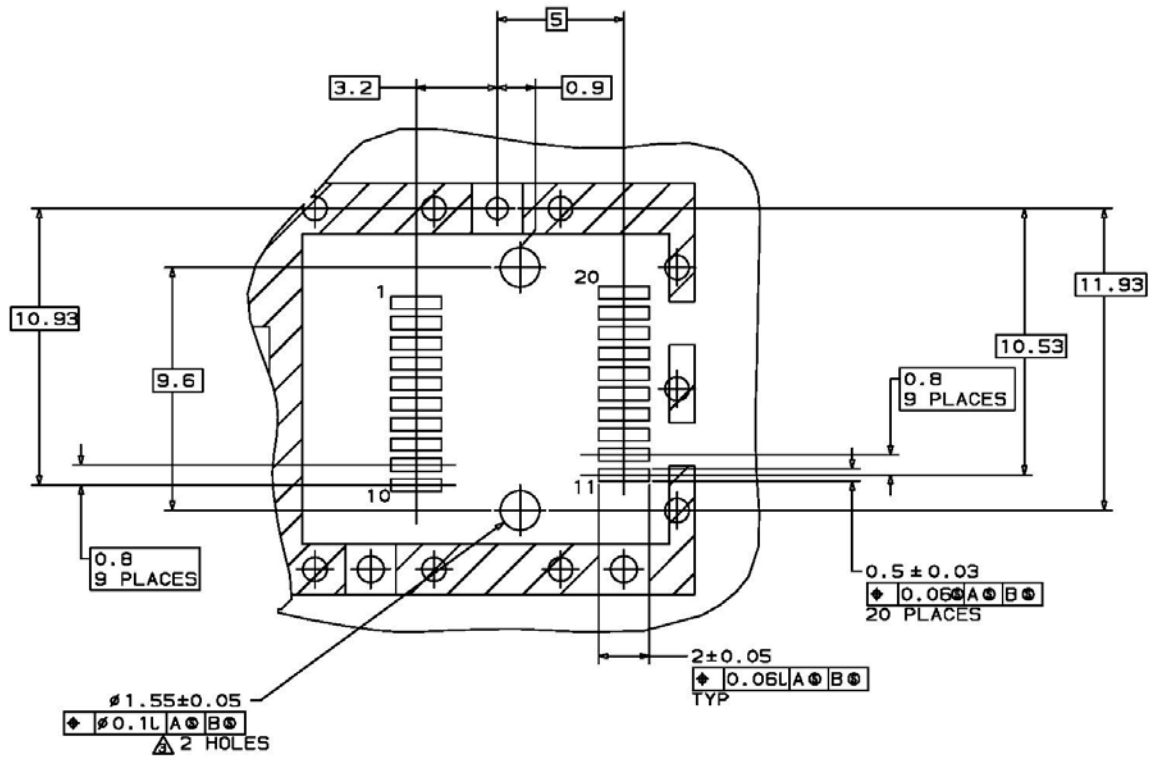

NOTES:

△ MINIMUM PITCH ILLUSTRATED, ENGLISH DIMENSIONS ARE FOR REFERENCE ONLY

2. NOT RECOMMENDED FOR PCI EXPANSION CARD APPLICATIONS

## **XII. References**

- a. “Improved Pluggable Form Factor”, SFF Document Number SFF-8432, Revision 5.0, July 16, 2007.
- b. “Digital Monitoring Interface for Optical Transceivers”, SFF Document Number SFF-8472, Revision 11.0.
- c. “SFF-8431 Specifications for Enhanced Small Form Factor Pluggable Modules, SFP+”, SFF Document Number SFF-8431, Revision 4.1, July 6, 2009.
- d. Directive 2011/65/EU of the European Council Parliament and of the Council, “on the restriction of the use of certain hazardous substances in electrical and electronic equipment”. Certain products may use one or more exemptions as allowed by the Directive.
- e. Small Form Factor Pluggable (SFP) Transceiver Multi-source Agreement (MSA), September 14, 2000.

## **XIII. For More Information**

Finisar Corporation  
1389 Moffett Park Drive  
Sunnyvale, CA 94089-1133  
Tel. 1-408-548-1000  
Fax 1-408-541-6138  
[sales@finisar.com](mailto:sales@finisar.com)  
[www.finisar.com](http://www.finisar.com)



Компания «ЭлектроПласт» предлагает заключение долгосрочных отношений при поставках импортных электронных компонентов на взаимовыгодных условиях!

Наши преимущества:

- Оперативные поставки широкого спектра электронных компонентов отечественного и импортного производства напрямую от производителей и с крупнейших мировых складов;
- Поставка более 17-ти миллионов наименований электронных компонентов;
- Поставка сложных, дефицитных, либо снятых с производства позиций;
- Оперативные сроки поставки под заказ (от 5 рабочих дней);
- Экспресс доставка в любую точку России;
- Техническая поддержка проекта, помощь в подборе аналогов, поставка прототипов;
- Система менеджмента качества сертифицирована по Международному стандарту ISO 9001;
- Лицензия ФСБ на осуществление работ с использованием сведений, составляющих государственную тайну;
- Поставка специализированных компонентов (Xilinx, Altera, Analog Devices, Intersil, Interpoint, Microsemi, Aeroflex, Peregrine, Syfer, Eurofarad, Texas Instrument, Miteq, Cobham, E2V, MA-COM, Hittite, Mini-Circuits, General Dynamics и др.);

Помимо этого, одним из направлений компании «ЭлектроПласт» является направление «Источники питания». Мы предлагаем Вам помощь Конструкторского отдела:

- Подбор оптимального решения, техническое обоснование при выборе компонента;
- Подбор аналогов;
- Консультации по применению компонента;
- Поставка образцов и прототипов;
- Техническая поддержка проекта;
- Защита от снятия компонента с производства.



#### Как с нами связаться

**Телефон:** 8 (812) 309 58 32 (многоканальный)

**Факс:** 8 (812) 320-02-42

**Электронная почта:** [org@eplast1.ru](mailto:org@eplast1.ru)

**Адрес:** 198099, г. Санкт-Петербург, ул. Калинина, дом 2, корпус 4, литера А.