

PROPER USE GUIDELINES

Cumulative Trauma Disorders can result from the prolonged use of manually powered hand tools. Hand tools are intended for occasional use and low volume applications. A wide selection of powered application equipment for extended-use, production operations is available.

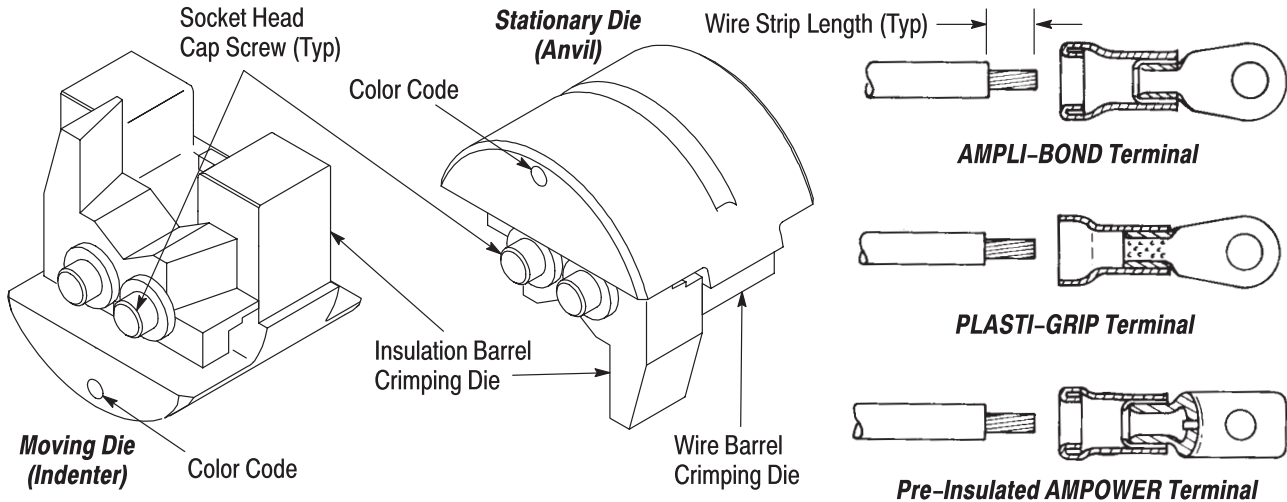

| WIRE SIZE (AWG) | WIRE STRIP LENGTH | | | | TERMINAL COLOR CODE | DIE SET | |
|-----------------|-------------------|--------------|--------------|--------------|---------------------|-------------|------------|
| | AMPLI-BOND | | PLASTI-GRIP | | | PART NUMBER | COLOR CODE |
| | MINIMUM | MAXIMUM | MINIMUM | MAXIMUM | | | |
| 8 | 11.51 [.453] | 12.29 [.484] | 11.51 [.453] | 12.29 [.484] | Red | 1490534-1 | Red |
| 6 | | | 15.47 [.609] | 16.26 [.640] | Blue | 1490535-1 | Blue |
| 4 | | | 15.47 [.609] | 16.26 [.640] | Yellow | 1490536-1 | Yellow |
| 2 | | | 11.51 [.453] | 12.29 [.484] | Red | 1490410-1 | Red |

Figure 1

1. INTRODUCTION

This instruction sheet provides information on product application and a maintenance and inspection procedure for the crimping dies listed in Figure 1. The dies are used in Hydraulic Crimping Head 1490746-1 and Hydraulic Hand Tool 1490749-1. For detailed information on the crimping head and hand tool, refer to the instructions packaged with these tools.

These dies are designed to crimp AMPLI-BOND and PLASTI-GRIP terminals on wire sizes 8 to 2 AWG, and Pre-Insulated AMPOWER terminals on wire size 2 AWG. Dies are coated with a preservative to prevent rust and corrosion. Wipe preservative from dies, particularly from crimping areas.

NOTE All dimensions in this document are in millimeters [with inches in brackets]. Illustrations and figures are for reference only and are not drawn to scale.

2. DIE INSTALLATION AND REMOVAL (Figure 2)



Do not operate tool without dies.



Avoid personal injury. Always keep fingers clear of dies when activating power unit.

2.1. Die Insertion

1. Refer to the chart in Figure 1 and verify that you have the proper die set for the terminal and wire size being used.
2. Before inserting dies in head, loosen socket head cap screws holding insulation crimping section of dies in place. See Figure 1. If screws are not loosened, dies may not fit into head of tool because of close tolerance.
3. Release the button and rock the die back-and-forth until the nest snaps in place.

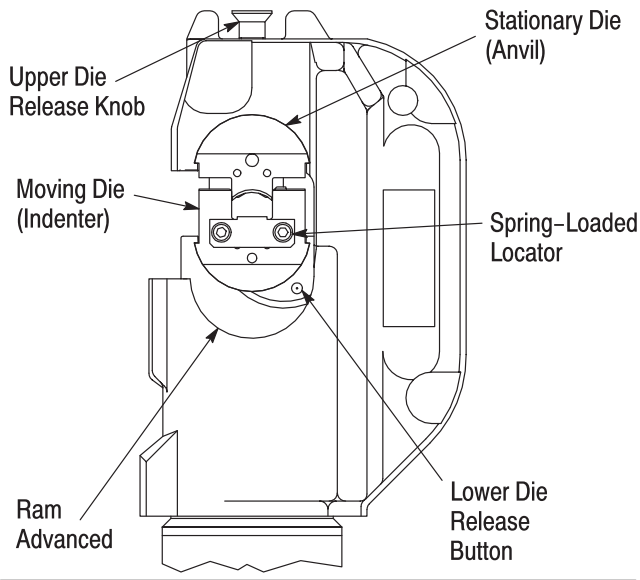

Figure 2

4. Activate the power unit until the lower die release button located in the ram is exposed.
5. Depress the release button and slide the indenter into place.
6. Release the button and rock the indenter back-and-forth until the die snaps in place.

NOTE *Moving die must be properly oriented to mate with the stationary die.*

7. Tighten the socket head cap screws holding the insulation crimp section of dies.
8. Activate the power unit to allow ram to return to the “down” position.
9. Lift the upper release located in the C-head and slide the anvil into place.

2.2. Die Removal

1. Lift the upper release located in the C-head and slide the anvil out of the head.
2. Activate the power unit until the lower die release button located in the ram is exposed.
3. Depress the release button and slide the indenter out of the ram.

3. OPERATION

3.1. Wire Stripping and Crimping Procedure

DANGER *Avoid personal injury. When operating power unit, exercise caution while holding terminals or wire near crimping area. Never place anything in the dies except terminals.*

1. Strip wire to dimensions listed in Figure 1. Do NOT nick or cut conductor strands.
2. Insert stripped wire in terminal. End of wire must be flush with or extend beyond edge of terminal wire barrel.
3. Place terminal on dies. See Figure 3, Detail A. Bottom of terminal tongue should face stationary die and terminal wire barrel should rest against spring-loaded locator.

NOTE *When crimping pre-insulated AMPPOWER terminals in die 1490410-1, it will be necessary to remove the locator. Position the terminal in dies as shown in Figure 3, Detail B. Bottom of terminal tongue faces stationary die and rear of terminal tongue butts against the side of the die.*

4. Hold terminal in place and activate power unit to complete crimp. Remove crimped terminal.

NOTE *If terminal sticks in die after crimping, apply a rocking action to remove it from the die.*

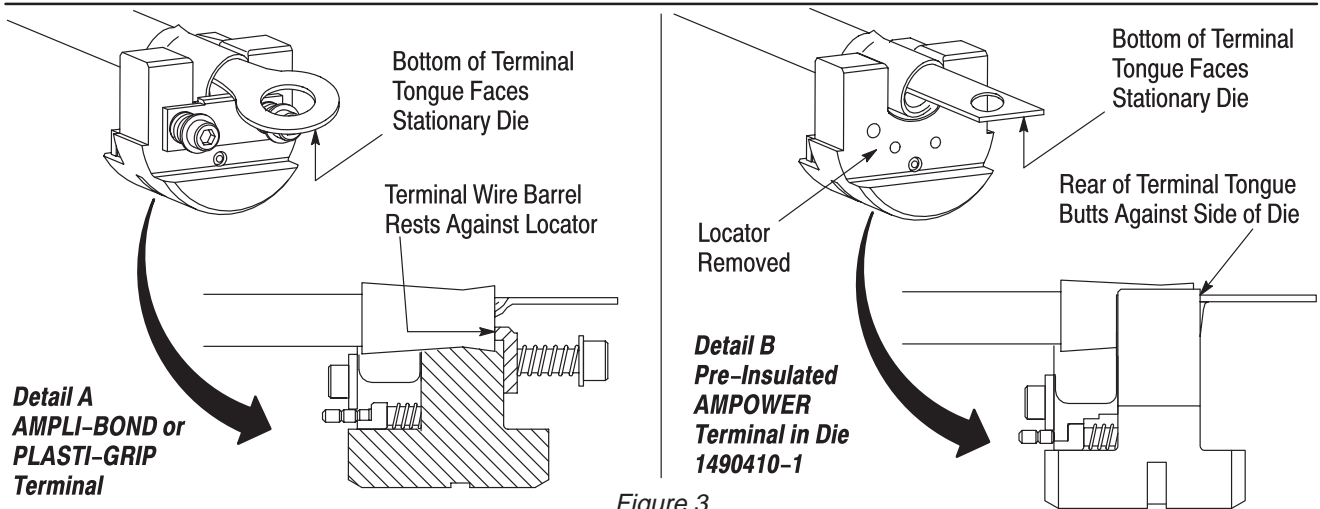

Figure 3

3.2. Insulation Crimp Adjustment

This adjustment is made to both stationary and moving dies after they have been placed in crimping head.

NOTE

Crimping Dies have four socket head cap screws and two pin-keys for insulation crimp adjustment.

1. The dies have three insulation crimp positions. The adjustment is made by moving a pin-key (see Figure 1). When the pin-key is pushed all the way in, the insulation crimping section of the die is in the loose position; when the pin-key is halfway out, the insulation crimping section of the die is in the medium position; when the pin-key is all the way out, the insulation crimping section of the die is in the tight position.
2. To adjust the insulation crimp, loosen socket head cap screws and push pin-key all the way in so that insulation crimp section of the die is in the loose position.
3. Press and hold insulation die down against the pin-key. This will prevent the spring-loaded pin-key from popping back.
4. Tighten socket head cap screws.

NOTE

Make certain insulation crimping sections of moving and stationary dies are both adjusted to the same position.

5. Perform a test crimp (refer to Paragraph 3.1).

NOTE

AMPLI-BOND and AMPOWER terminals provide a "grip" on wire insulation. PLASTI-GRIP terminals provide only a "support" for the wire.

6. Remove crimped terminal from dies and visually inspect the insulation crimp portion of terminal. The insulation crimp should "grip" wire insulation (when using AMPLI-BOND or AMPOWER terminals) or provide "support" for wire insulation (when using PLASTI-GRIP terminals).
7. If the insulation crimp does not grip or support wire insulation as described in step 6, loosen socket head cap screws and set the pin-keys in the medium position. Then follow Steps 3 and 4.
8. Make another test crimp over previously crimped terminal.
9. Remove crimped terminal from dies and visually inspect insulation crimp.
10. Repeat adjustment as necessary until desired insulation crimp is obtained. Do NOT use a tighter setting than required.

11. Refer to Paragraph 3.4 and Figure 4 for crimp inspection procedure.

3.3. Color Code

Terminals and dies are color coded as listed and shown in Figure 1. The dies have the terminal size stamped in the wire barrel crimp sections of both the moving and stationary dies. When crimped, the wire size will appear on both sides of the terminal wire barrel. The wire size appearing on the crimped wire barrel should always agree with the wire size stamped on the terminal tongue.

3.4. Crimp Inspection

Inspect crimped terminals by checking the features described in Figure 4.

NOTE

AMPLI-BOND terminals are shown in Figure 4. Inspection procedure is the same for AMPOWER and PLASTI-GRIP terminals.

Use only the terminals that meet the conditions shown in the "ACCEPT" column. "REJECT" terminals can be avoided through careful use of instructions in Paragraphs 3.1 and 3.2, and by performing regular die maintenance described in Section 4.

4. MAINTENANCE/INSPECTION

Regular inspections should be performed by quality control personnel. A record of scheduled inspections should remain with the dies and/or be supplied to the supervisory personnel responsible for the dies. Though recommendations call for at least one inspection a month, the inspection frequency should be based on the amount of use, ambient working conditions, operator training and skill, and established company standards. These inspections should be performed in the following sequence:

4.1. Cleaning

Do not allow deposits of dirt, grease, or foreign matter to accumulate in the die closure area, or on the bottoming surfaces of the dies. These deposits may prevent the dies from bottoming fully and may also cause excessive wear in the die closure surfaces, thereby affecting the quality of the crimp. The dies should be wiped clean frequently with a clean cloth.

4.2. Visual Inspection

Visually inspect the die closure surfaces for flattened, broken, pitted, or chipped conditions. Although dies may gage within permissible limits, worn or damaged die closure surfaces are objectionable and can affect the quality of the crimp. Examples of possible damaged die surfaces are shown in Figure 5.

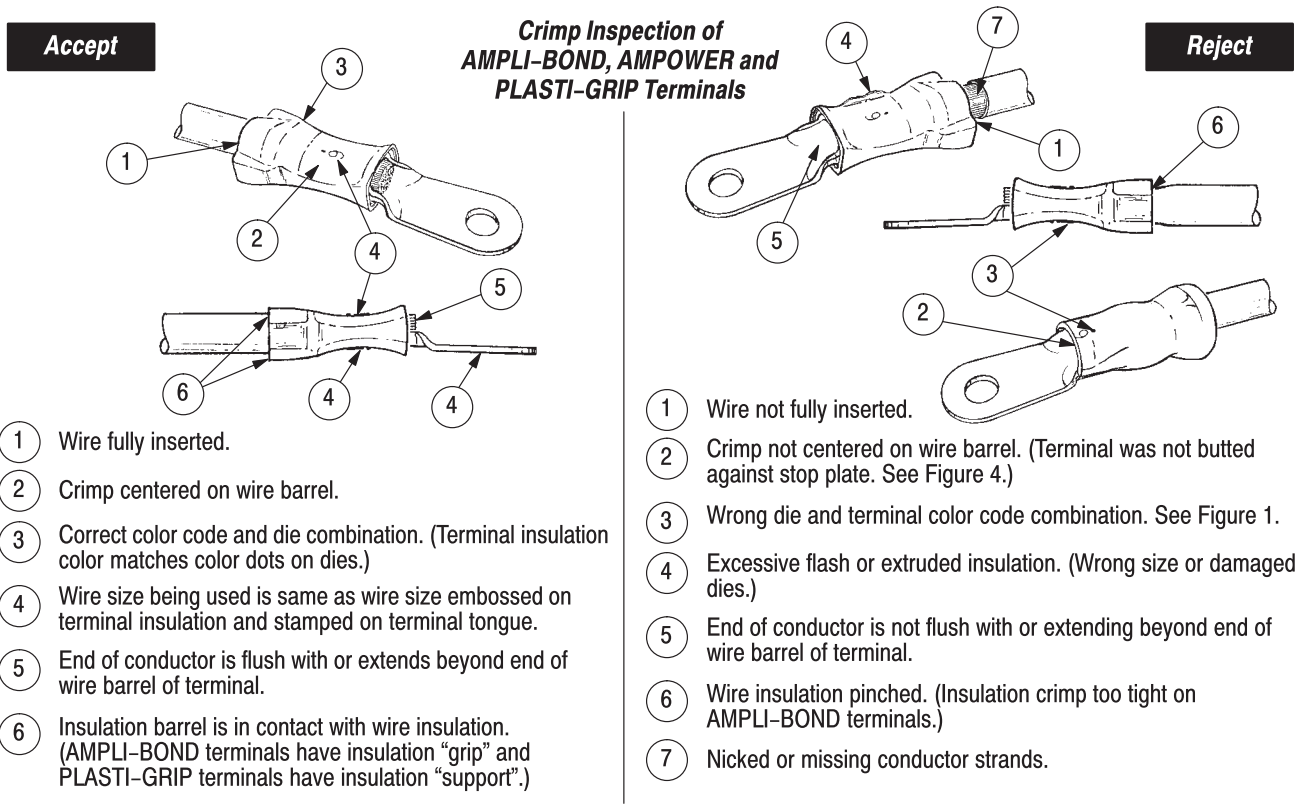

Figure 4

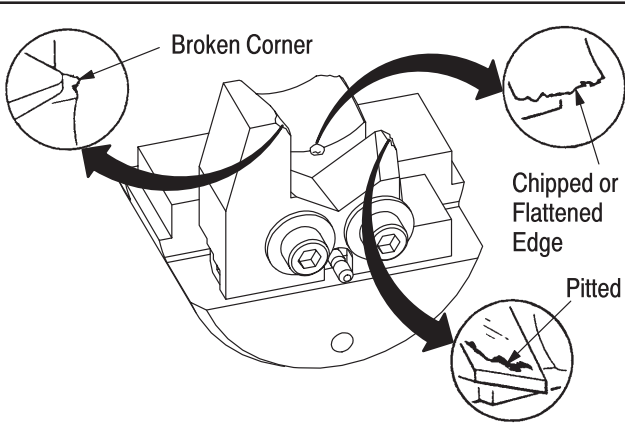

Figure 5

4.3. Plug Gage Inspection

Every die set is inspected and tested for proper die closure dimensions before packaging. An inspection should be performed periodically to check the die closure for excessive wear. A suggested gage design and the GO and NO-GO dimensions of the plug gage elements are shown in Figures 6 and 7. The following procedure is recommended for inspecting the die set.

1. Clean oil or dirt from the bottoming surfaces, die closure surfaces, and plug gage elements.
2. Remove two socket head cap screws and locator from moving die. See Figure 8, Detail A. This will provide access to the wire barrel dies for plug gaging.

3. Assemble stationary and moving dies so that wire barrel dies are bottomed, but not under pressure. See Figure 8.
4. With wire barrel dies bottomed, inspect the wire barrel crimp die closure using the proper plug gage. Hold gage in straight alignment with the die closure and carefully try to insert, without forcing, the GO element. See Figure 8, Detail A. The GO element must pass completely through the wire barrel crimp die closure.
5. Try to insert the NO-GO element. The NO-GO element may enter partially, but must not pass completely through the wire barrel die closure.
6. Re-install locator and secure with the two socket head cap screws.
7. Loosen socket head cap screws from both stationary and moving insulation dies and move pin-keys all the way out so that insulation crimping sections of dies are in the tight position. See Figure 8, Detail B.
8. Press and hold insulation die down against pin-key, and tighten the socket head cap screws.
9. With wire barrel dies bottomed, inspect the insulation crimp die closure using the proper plug gage in the same manner as steps 3 through 5. See Figure 8, Detail B.
10. If both wire barrel and insulation die closures meet the plug gage conditions, the dies are considered to be dimensionally correct.

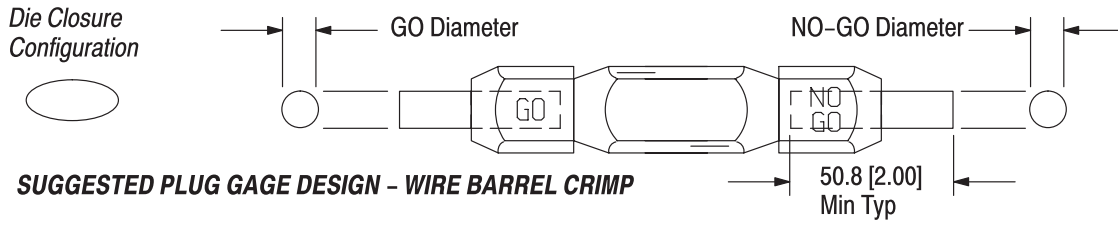

SUGGESTED PLUG GAGE DESIGN - WIRE BARREL CRIMP

| TOOL NUMBER | GAGE ELEMENT DIAMETER | |
|-------------|---------------------------|---------------------------|
| | GO | NO-GO |
| 1490534-1 | 5.105-5.113 [.2010-.2013] | 5.255-5.258 [.2069-.2070] |
| 1490535-1 | 6.020-6.027 [.2370-.2373] | 6.170-6.172 [.2429-.2430] |
| 1490536-1 | 6.833-6.840 [.2690-.2693] | 6.982-6.985 [.2749-.2750] |
| 1490410-1 | 8.103-8.110 [.3190-.3193] | 8.252-8.255 [.3249-.3250] |

Figure 6

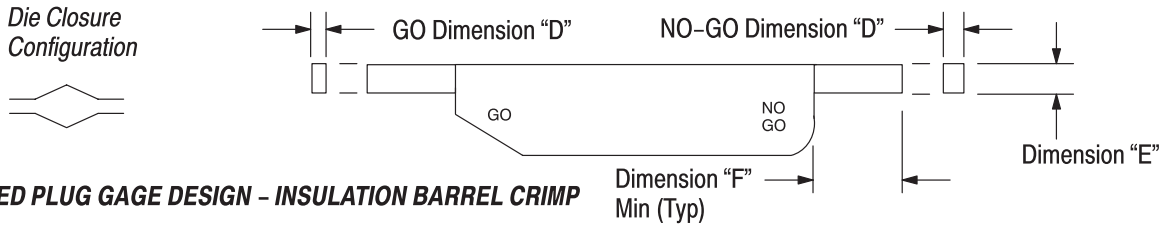

SUGGESTED PLUG GAGE DESIGN - INSULATION BARREL CRIMP

| TOOL NUMBER | GAGE ELEMENT DIMENSION "D" | | DIMENSION "E" | DIMENSION "F" |
|-------------|----------------------------|---------------------------|---------------|---------------|
| | GO | NO-GO | | |
| 1490534-1 | 3.861-3.868 [.1520-.1523] | 4.366-4.369 [.1719-.1720] | 7.14 [.281] | 6.35 [.250] |
| 1490535-1 | 4.216-4.224 [.1660-.1663] | 4.722-4.724 [.1859-.1860] | 7.92 [.312] | 11.18 [.440] |
| 1490536-1 | 4.115-4.122 [.1620-.1623] | 4.620-4.623 [.1819-.1820] | 8.13 [.320] | 11.94 [.470] |
| 1490410-1 | 4.623-4.630 [.1820-.1823] | 5.128-5.131 [.2019-.2020] | 10.29 [.405] | 11.94 [.470] |

Figure 7

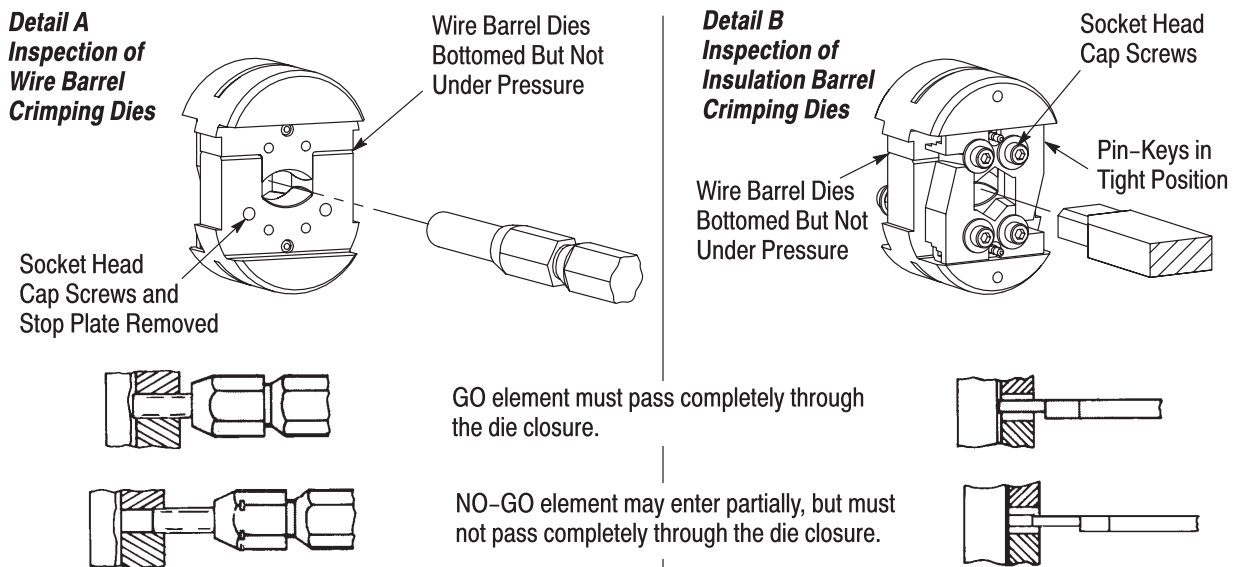

Figure 8

5. REPLACEMENT AND REPAIR

The parts listed in Figure 9 are customer-replaceable. A complete inventory can be stocked and controlled to prevent lost time when replacement of parts is necessary. Order replacement parts through your Tyco Electronics Representative, or call 1-800-526-5142, or send a facsimile of your purchase order to 1-717-986-7605, or write to:

CUSTOMER SERVICE (38-35)
 TYCO ELECTRONICS CORPORATION
 P.O. BOX 3608
 HARRISBURG, PA 17105-3608

Dies may be returned for evaluation and repair. For die repair service, contact a representative at 1-800-526-5136.

6. REVISION SUMMARY

- Updated document to corporate requirements
- New format

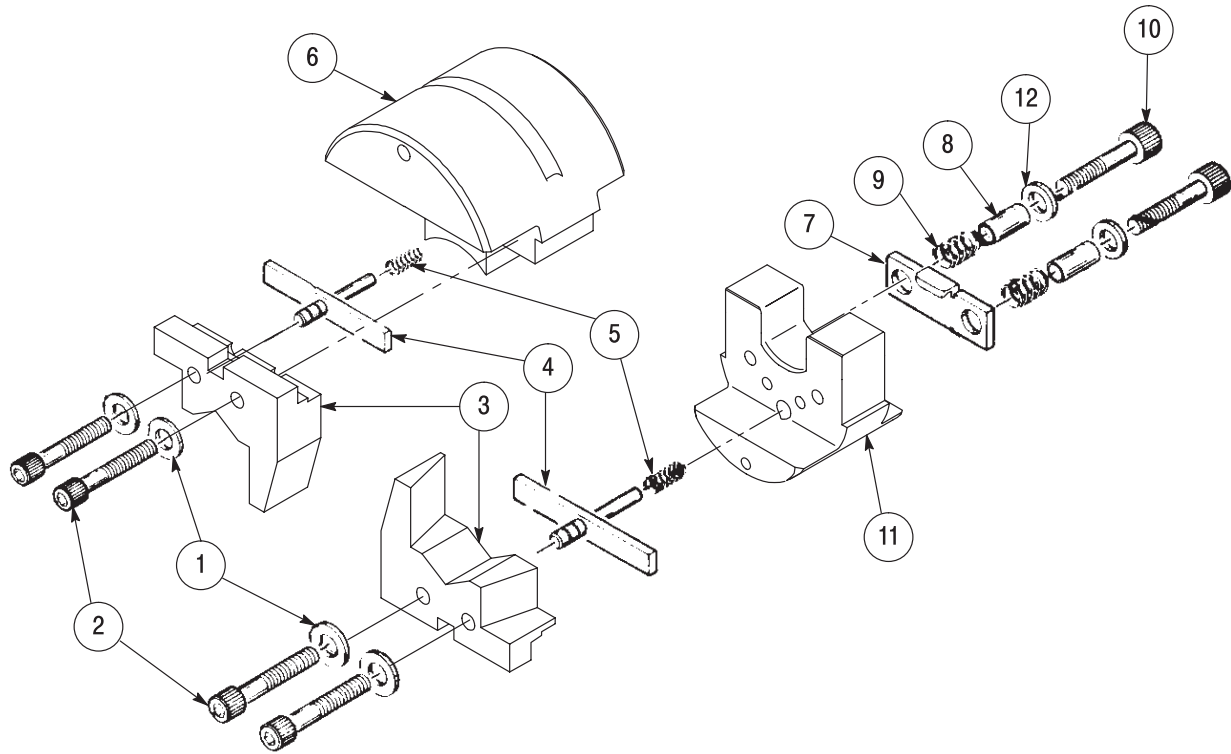

| ITEM | DESCRIPTION | QTY PER DIE SET | DIE SET NUMBERS AND COMPONENT PART NUMBERS | | | |
|------|-------------------|-----------------|--|------------|------------|-----------|
| | | | 1490534-1 | 1490535-1 | 1490536-1 | 1490410-1 |
| 1 | Washer | 4 | 306098-3 | 306098-3 | 306098-3 | 306098-3 |
| 2 | Screw | 4 | 23030-5 | 23030-7 | 23030-7 | 23030-7 |
| 3 | Insulation Insert | 2 | 313339-2 | 1490540-1 | 313339-1 | 45861-1 |
| 4 | Adjustment Key | 2 | 308947-1 | 313292-2 | 313292-1 | 313292-1 |
| 5 | Spring | 2 | 302380 | 302380 | 302380 | 302380 |
| 6 | Anvil Barrel | 1 | 1490409-1 | 1490409-2 | 1490409-3 | 1490409-4 |
| 7 | Locator | 1 | 307130-1 | 307130-1 | 307130-2 | 307130-3 |
| 8 | Sleeve | 2 | 306363 | 306363 | 306363 | 306363 |
| 9 | Spring | 2 | 3-304668-5 | 3-304668-5 | 3-304668-5 | 6-59683-8 |
| 10 | Screw | 2 | 2-21000-8 | 2-21000-8 | 2-21000-8 | 2-21000-8 |
| 11 | Indenter Barrel | 1 | 1490411-1 | 1490411-2 | 1490411-3 | 1490411-4 |
| 12 | Washer | 2 | 1-59681-8 | 1-59681-8 | 1-59681-8 | 1-59681-8 |

Figure 9



Компания «ЭлектроПласт» предлагает заключение долгосрочных отношений при поставках импортных электронных компонентов на взаимовыгодных условиях!

Наши преимущества:

- Оперативные поставки широкого спектра электронных компонентов отечественного и импортного производства напрямую от производителей и с крупнейших мировых складов;
- Поставка более 17-ти миллионов наименований электронных компонентов;
- Поставка сложных, дефицитных, либо снятых с производства позиций;
- Оперативные сроки поставки под заказ (от 5 рабочих дней);
- Экспресс доставка в любую точку России;
- Техническая поддержка проекта, помощь в подборе аналогов, поставка прототипов;
- Система менеджмента качества сертифицирована по Международному стандарту ISO 9001;
- Лицензия ФСБ на осуществление работ с использованием сведений, составляющих государственную тайну;
- Поставка специализированных компонентов (Xilinx, Altera, Analog Devices, Intersil, Interpoint, Microsemi, Aeroflex, Peregrine, Syfer, Eurofarad, Texas Instrument, Miteq, Cobham, E2V, MA-COM, Hittite, Mini-Circuits, General Dynamics и др.);

Помимо этого, одним из направлений компании «ЭлектроПласт» является направление «Источники питания». Мы предлагаем Вам помощь Конструкторского отдела:

- Подбор оптимального решения, техническое обоснование при выборе компонента;
- Подбор аналогов;
- Консультации по применению компонента;
- Поставка образцов и прототипов;
- Техническая поддержка проекта;
- Защита от снятия компонента с производства.



Как с нами связаться

Телефон: 8 (812) 309 58 32 (многоканальный)

Факс: 8 (812) 320-02-42

Электронная почта: org@eplast1.ru

Адрес: 198099, г. Санкт-Петербург, ул. Калинина, дом 2, корпус 4, литера А.