

# PN Silicon Photodiode

## OP900SL



### Features:

- Narrow receiving angle
- Enhanced temperature range
- Ideal for direct mounting to PCBoard
- Fast switching speed
- Linear response vs. irradiance
- Mechanically and spectrally matched to OP123 emitters

### Description:

Each **OP900SL** consists of a PN junction silicon photodiode mounted in a miniature glass-lensed hermetically sealed “pill” package. The lensing effect allows an acceptance half-angle of 18°, when measured from the optical axis to the half-power point.

*The OP900SL is mechanically and spectrally matched to the OP123 series emitters.*

Please refer to Application Bulletins 208 and 210 for additional design information and reliability (degradation) data, and to Application Bulletin 202 for pill-type soldering to PCBoard.

### Applications:

- Non-contact reflective object sensor
- Assembly line automation
- Machine automation
- Machine safety
- End of travel sensor
- Door sensor

Ordering Information		
Part Number	Sensor	Viewing Angle
OP900SL	Photodiode	35°

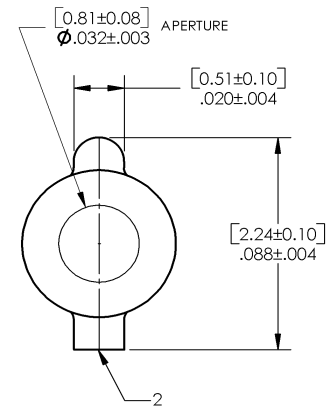
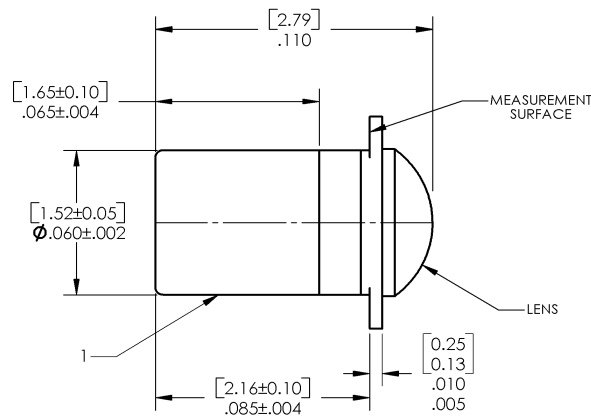

DIMENSIONS ARE IN: [MILLIMETERS]  
[INCHES]

Pin #	Sensor
1	Collector / Cathode
2	Emitter / Anode



RoHS

### General Note

TT Electronics reserves the right to make changes in product specification without notice or liability. All information is subject to TT Electronics' own data and is considered accurate at time of going to print.

OPTEK Technology, Inc.  
1645 Wallace Drive, Carrollton, TX 75006 | Ph: +1 972 323 2200  
www.optekinc.com | www.ttelectronics.com

### Electrical Specifications

Absolute Maximum Ratings ( $T_A = 25^\circ\text{C}$ unless otherwise noted)	
Reverse Voltage	100 V
Operating Temperature Range	$-65^\circ\text{C}$ to $+125^\circ\text{C}$
Storage Temperature Range	$-65^\circ\text{C}$ to $+150^\circ\text{C}$
Lead Soldering Temperature [1/16 inch (1.6 mm) from the case for 5 seconds with soldering iron]	$260^\circ\text{C}^{(1)}$
Power Dissipation	$50\text{ mW}^{(2)}$

Electrical Characteristics ( $T_A = 25^\circ\text{C}$ unless otherwise noted)						
SYMBOL	PARAMETER	MIN	TYP	MAX	UNITS	TEST CONDITIONS
$I_L$	Light Current	8	14	-	$\mu\text{A}$	$V_R = 10\text{ V}$ , $E_E = 20\text{ mW/cm}^2$ <sup>(3)(4)</sup>
$I_D$	Dark Current	-	-	10	nA	$V_R = 10\text{ V}$ , $E_E = 0$ <sup>(3)</sup>
$V_{(BR)R}$	Reverse Voltage Breakdown	100	150	-	V	$I_R = 100\ \mu\text{A}$
$t_r$	Rise Time	-	100	-	ns	$V_R = 50\text{ V}$ , $I_L = 8\ \mu\text{A}$ , $R_L = 1\text{ k}\Omega$ (see test circuit)
$t_f$	Fall Time	-	100	-		

Notes:

- (1) RMA flux is recommended. Duration can be extended to 10 seconds maximum when flow soldering.
- (2) Derate linearly  $0.5\text{ mW}/^\circ\text{C}$  above  $25^\circ\text{C}$ .
- (3) Junction temperature maintained at  $25^\circ\text{C}$ .
- (4) Light source is an unfiltered tungsten bulb operating at  $CT = 2870\text{ K}$  or equivalent infrared source..

General Note

TT Electronics reserves the right to make changes in product specification without notice or liability. All information is subject to TT Electronics' own data and is considered accurate at time of going to print.

OPTEK Technology, Inc.  
1645 Wallace Drive, Carrollton, TX 75006 | Ph: +1 972 323 2200  
www.optekinc.com | www.ttelectronics.com

# PN Silicon Photodiode

OP900SL



## Performance

OP900SL

Typical Spectral Response

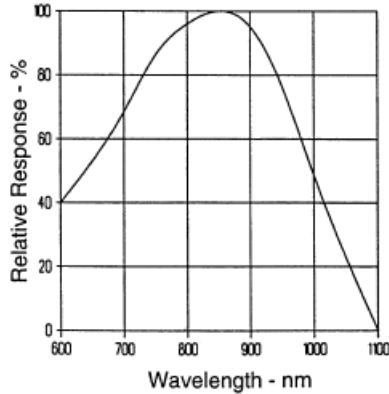

Coupling Characteristics of OP123 and OP900SL

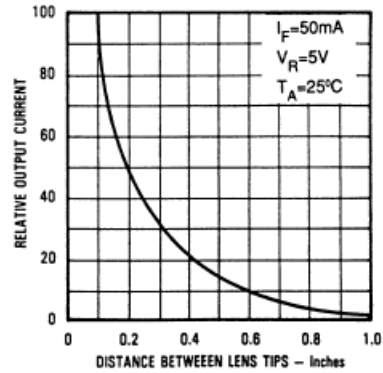

Dark Current vs. Ambient Temperature

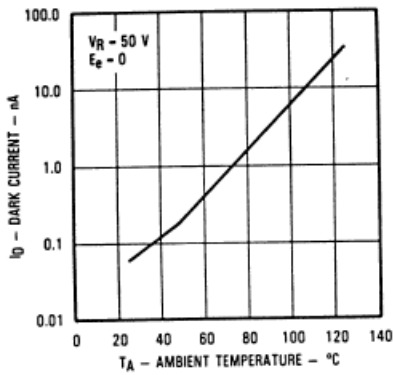

Normalized Light Current vs. Ambient Temperature

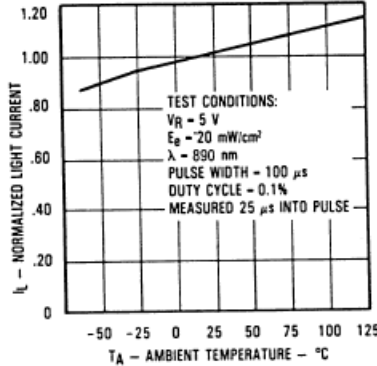

Total Capacitance vs. Reverse Voltage

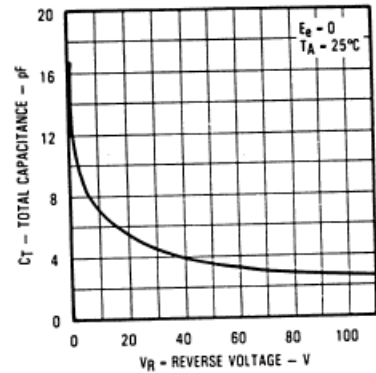

Light Current vs. Irradiance

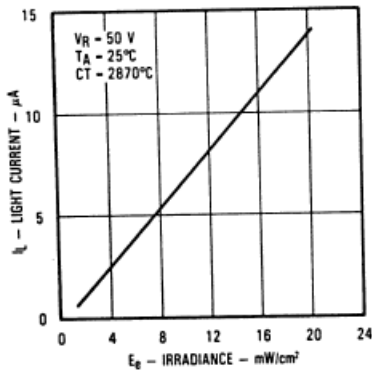

Switching Time Test Circuit

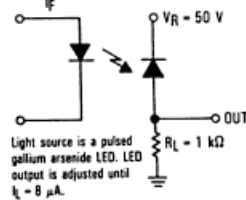

Light Current vs. Angular Displacement

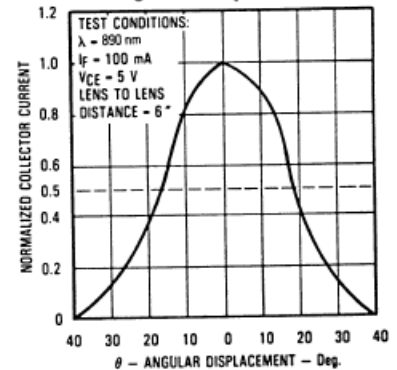

General Note

TT Electronics reserves the right to make changes in product specification without notice or liability. All information is subject to TT Electronics' own data and is considered accurate at time of going to print.

OPTeK Technology, Inc.  
1645 Wallace Drive, Carrollton, TX 75006 | Ph: +1 972 323 2200  
www.optekinc.com | www.ttelectronics.com



Компания «ЭлектроПласт» предлагает заключение долгосрочных отношений при поставках импортных электронных компонентов на взаимовыгодных условиях!

Наши преимущества:

- Оперативные поставки широкого спектра электронных компонентов отечественного и импортного производства напрямую от производителей и с крупнейших мировых складов;
- Поставка более 17-ти миллионов наименований электронных компонентов;
- Поставка сложных, дефицитных, либо снятых с производства позиций;
- Оперативные сроки поставки под заказ (от 5 рабочих дней);
- Экспресс доставка в любую точку России;
- Техническая поддержка проекта, помощь в подборе аналогов, поставка прототипов;
- Система менеджмента качества сертифицирована по Международному стандарту ISO 9001;
- Лицензия ФСБ на осуществление работ с использованием сведений, составляющих государственную тайну;
- Поставка специализированных компонентов (Xilinx, Altera, Analog Devices, Intersil, Interpoint, Microsemi, Aeroflex, Peregrine, Syfer, Eurofarad, Texas Instrument, Miteq, Cobham, E2V, MA-COM, Hittite, Mini-Circuits, General Dynamics и др.);

Помимо этого, одним из направлений компании «ЭлектроПласт» является направление «Источники питания». Мы предлагаем Вам помощь Конструкторского отдела:

- Подбор оптимального решения, техническое обоснование при выборе компонента;
- Подбор аналогов;
- Консультации по применению компонента;
- Поставка образцов и прототипов;
- Техническая поддержка проекта;
- Защита от снятия компонента с производства.



#### Как с нами связаться

**Телефон:** 8 (812) 309 58 32 (многоканальный)

**Факс:** 8 (812) 320-02-42

**Электронная почта:** [org@eplast1.ru](mailto:org@eplast1.ru)

**Адрес:** 198099, г. Санкт-Петербург, ул. Калинина, дом 2, корпус 4, литера А.