

### General Description

The 8N0QV01 is a Quad-Frequency Programmable VCXO with very flexible frequency and pull-range programming capabilities. The device uses IDT's Fourth Generation FemtoClock® NG technology for an optimum of high clock frequency and low phase noise performance. The device accepts 2.5V or 3.3V supply and is packaged in a small, lead-free (RoHS 6) 10-lead ceramic 5mm x 7mm x 1.55mm package.

Besides the four default power-up frequencies set by the FSEL0 and FSEL1 pins, the 8N0QV01 can be programmed via the I<sup>2</sup>C interface to any output clock frequency between 15.476MHz to 260MHz to a very high degree of precision with a frequency step size of 435.9Hz ÷ N (N: PLL post divider). Since the FSEL0 and FSEL1 pins are mapped to four independent PLL, P, M and N divider registers (P, MINT, MFRAC and N), reprogramming those registers to other frequencies under control of FSEL0 and FSEL1 is supported. The extended temperature range supports wireless infrastructure, telecommunication and networking end equipment requirements.

### Features

- Fourth generation FemtoClock® NG technology
- Programmable clock output frequency from 15.476MHz to 260MHz
- Four power-up default frequencies (see part number order codes), re-programmable by I<sup>2</sup>C
- I<sup>2</sup>C programming interface for the output clock frequency, APR and internal PLL control registers
- Frequency programming resolution is 435.9Hz ÷ N
- Absolute pull-range (APR) programmable from ±2.5 to ±727.5ppm
- One 2.5V, 3.3V LVCMOS clock output
- Two control inputs for the power-up default frequency
- LVCMOS/LVTTL compatible control inputs
- RMS phase jitter @ 156.25MHz (12kHz - 20MHz): 0.635ps (typical)
- RMS phase jitter @ 156.25MHz (1kHz - 40MHz): 0.850ps (typical)
- 2.5V or 3.3V supply voltage modes
- -40°C to 85°C ambient operating temperature
- Lead-free (RoHS 6) packaging

### Block Diagram

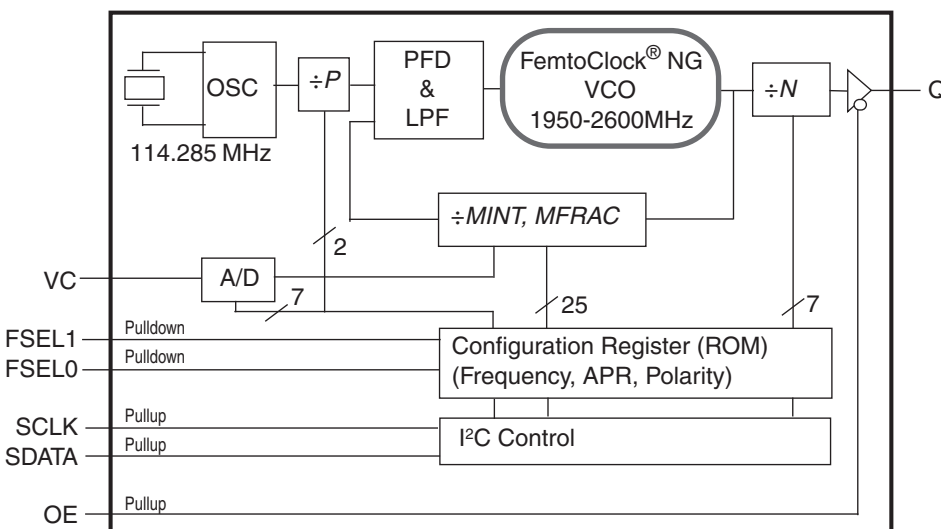

### Pin Assignment

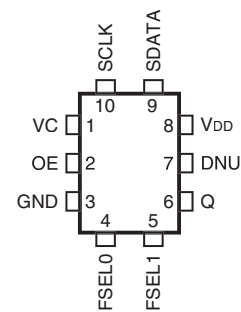

**IDT8N0QV01 Rev H**  
**10-lead ceramic 5mm x 7mm x 1.55mm**  
**package body**  
**CD Package**  
**Top View**

### Block Diagram with Programming Registers

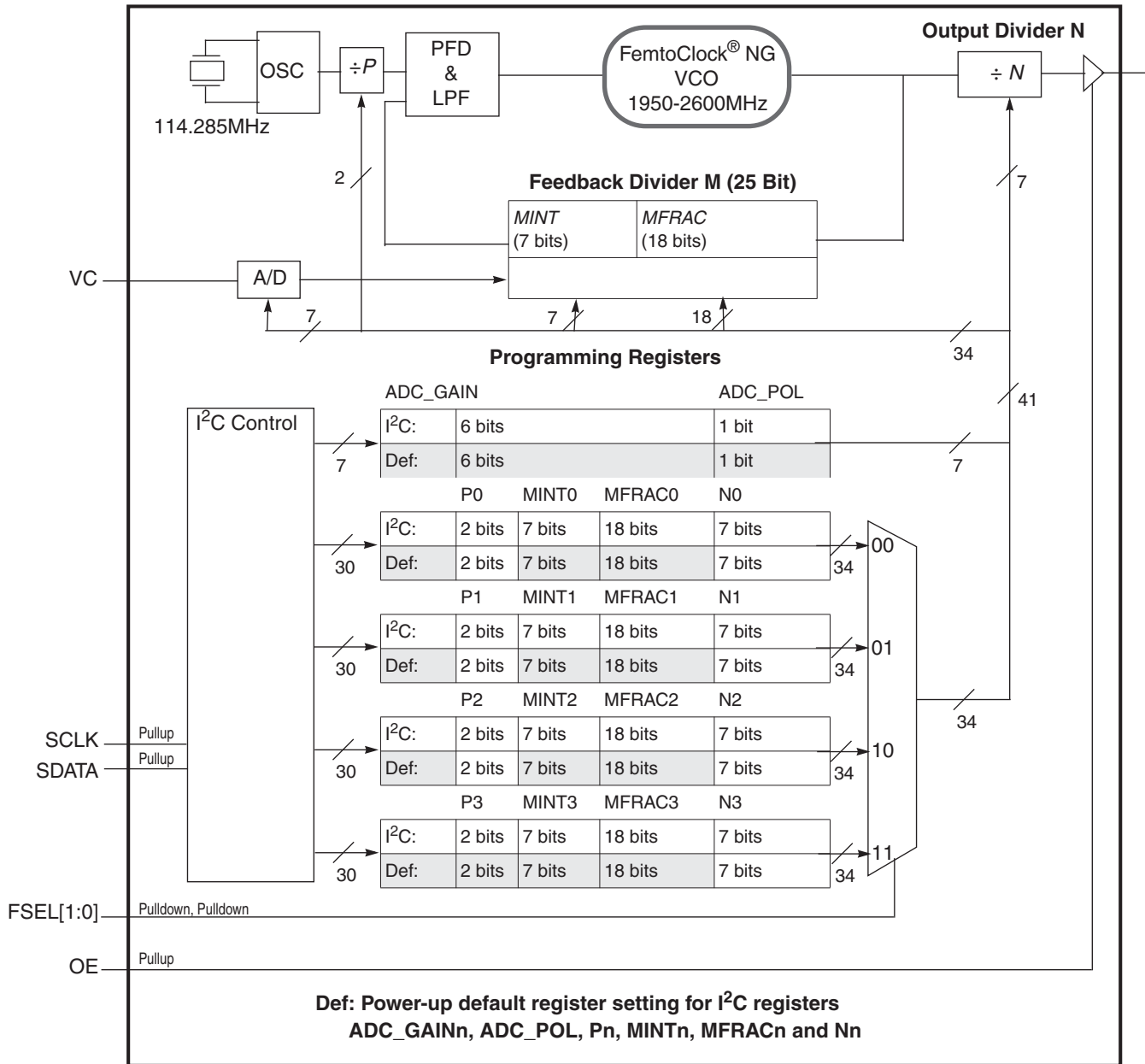

## Pin Description and Characteristics

**Table 1. Pin Descriptions**

Number	Name	Type		Description
1	VC	Input		VCXO Control Voltage. The control voltage versus frequency characteristics are set by the ADC_GAIN[5:0] register bits.
2	OE	Input	Pullup	Output enable pin. See Table 3B for function. LVCMOS/LVTTL interface levels.
3	GND	Power		Power supply ground.
5, 4	FSEL1, FSEL0	Input	Pulldown	Default frequency select pins. LVCMOS/LVTTL interface levels. Refer to the FemtoClock NG Ceramic-Package XO and VCXO Ordering Product Information document for default frequency order codes.
6	Q	Output		Clock output. LVCMOS/LVTTL interface levels.
7	DNU			Do not use. Do not connect.
8	V <sub>DD</sub>	Power		Positive power supply.
9	SDATA	Input	Pullup	I <sup>2</sup> C Data Input. LVCMOS/LVTTL interface levels.
10	SCLK	Input	Pullup	I <sup>2</sup> C Clock Input. LVCMOS/LVTTL interface levels.

NOTE: *Pullup* and *Pulldown* refer to internal input resistors. See Table 2, *Pin Characteristics*, for typical values.

**Table 2. Pin Characteristics**

Symbol	Parameter	Test Conditions	Minimum	Typical	Maximum	Units
C <sub>IN</sub>	Input Capacitance	FSEL[1:0], SDATA, SCLK, OE		3.5		pF
		VC		10		pF
C <sub>PD</sub>	Power Dissipation Capacitance	V <sub>DD</sub> = 3.465V or 2.625V		8		pF
R <sub>PULLUP</sub>	Input Pullup Resistor			50		kΩ
R <sub>PULLDOWN</sub>	Input Pulldown Resistor			50		kΩ
R <sub>OUT</sub>	Output Impedance	Q	V <sub>DD</sub> = 3.3V	15		Ω
			V <sub>DD</sub> = 2.5V	19		Ω

## Function Tables

**Table 3A. Default Frequency Selection**

Input		Operation
FSEL1	FSEL0	
0 (default)	0 (default)	Default frequency 0.
0	1	Default frequency 1.
1	0	Default frequency 2.
1	1	Default frequency 3.

NOTE: The default frequency is the output frequency after power-up. One of four default frequencies is selected by FSEL[1:0]. See programming section for details.

**Table 3B. OE Configuration**

Input	Output Enable
OE	
0	Output Q are in high-impedance state.
1 (default)	Outputs are enabled.

NOTE: OE is an asynchronous control.

## Principles of Operation

The block diagram consists of the internal 3<sup>rd</sup> overtone crystal and oscillator which provide the reference clock  $f_{XTAL}$  of 114.285MHz. The PLL includes the FemtoClock NG VCO along with the pre-divider ( $P$ ), the feedback divider ( $M$ ) and the post divider ( $N$ ). The  $P$ ,  $M$ , and  $N$  dividers determine the output frequency based on the  $f_{XTAL}$  reference and must be configured correctly for proper operation. The feedback divider is fractional supporting a huge number of output frequencies. The configuration of the feedback divider to integer-only values results in an improved output phase noise characteristics at the expense of the range of output frequencies. In addition, internal registers are used to hold up to four different factory pre-set  $P$ ,  $M$ , and  $N$  configuration settings. These default pre-sets are stored in the I<sup>2</sup>C registers at power-up. Each configuration is selected via the FSEL[1:0] pins and can be read back using the SCLK and SDATA pins.

The user may choose to operate the device at an output frequency different than that set by the factory. After power-up, the user may write new  $P$ ,  $N$  and  $M$  settings into one or more of the four configuration registers and then use the FSEL[1:0] pins to select the newly programmed configuration. Note that the I<sup>2</sup>C registers are volatile and a power supply cycle will reload the pre-set factory default conditions.

If the user does choose to write a different  $P$ ,  $M$ , and  $N$  configuration, it is recommended to write to a configuration which is not currently selected by FSEL[1:0] and then change to that configuration after the I<sup>2</sup>C transaction has completed. Changing the FSEL[1:0] controls results in an immediate change of the output frequency to the selected register values. The  $P$ ,  $M$ , and  $N$  frequency configurations support an output frequency range 15.476MHz to 260MHz.

The devices use the fractional feedback divider with a delta-sigma modulator for noise shaping and robust frequency synthesis capability. The relatively high reference frequency minimizes phase noise generated by frequency multiplication and allows more efficient shaping of noise by the delta-sigma modulator.

The output frequency is determined by the 2-bit pre-divider ( $P$ ), the feedback divider ( $M$ ) and the 7-bit post divider ( $N$ ). The feedback divider ( $M$ ) consists of both a 7-bit integer portion ( $MINT$ ) and an 18-bit fractional portion ( $MFRAC$ ) and provides the means for high-resolution frequency generation. The output frequency  $f_{OUT}$  is calculated by:

$$f_{OUT} = f_{XTAL} \cdot \frac{1}{P \cdot N} \cdot \left[ MINT + \frac{MFRAC + 0.5}{2^{18}} \right] \quad (1)$$

The four configuration registers for the  $P$ ,  $M$  ( $MINT$  &  $MFRAC$ ) and  $N$  dividers which are named  $P_n$ ,  $MINT_n$ ,  $MFRAC_n$  and  $N_n$  with  $n = 0$  to 3. “n” denominates one of the four possible configurations.

As identified previously, the configurations of  $P$ ,  $M$  ( $MINT$  &  $MFRAC$ ) and  $N$  divider settings are stored the I<sup>2</sup>C register, and the configuration loaded at power-up is determined by the FSEL[1:0] pins.

**Table 4. Frequency Selection**

Input		Selects	Register
FSEL1	FSEL0		
0 (def.)	0 (def.)	Frequency 0	P0, MINT0, MFRAC0, N0
0	1	Frequency 1	P1, MINT1, MFRAC1, N1
1	0	Frequency 2	P2, MINT2, MFRAC2, N2
1	1	Frequency 3	P3, MINT3, MFRAC3, N3

## Frequency Configuration

An order code is assigned to each frequency and VCXO pull range configuration programmed by the factory (default frequencies). For available order codes, see the *FemtoClock NG Ceramic-Package XO and VCXO Ordering Product Information* document.

For more information and guidelines on programming of the device for custom frequency configurations, programming for a specific VCXO pull range, the available APR (absolute pull range), the register description and the serial interface description, see the *FemtoClock NG Ceramic 5x7 Module Programming Guide*.

## Absolute Maximum Ratings

NOTE: Stresses beyond those listed under *Absolute Maximum Ratings* may cause permanent damage to the device. These ratings are stress specifications only. Functional operation of the product at these conditions or any conditions beyond those listed in the *DC Characteristics* or *AC Characteristics* is not implied. Exposure to absolute maximum rating conditions for extended periods may affect product reliability.

Item	Rating
Supply Voltage, $V_{DD}$	3.6V
Inputs, $V_I$	-0.5V to $V_{DD} + 0.5V$
Outputs, $I_O$ (LVCMOS)	-0.5V to $V_{DD} + 0.5V$
Outputs, $I_O$ (SDATA)	10mA
Package Thermal Impedance, $\theta_{JA}$	49.4°C/W (mps)
Storage Temperature, $T_{STG}$	-65°C to 150°C

## DC Electrical Characteristics

**Table 5A. Power Supply DC Characteristics,  $V_{DD} = 3.3V \pm 5\%$ ,  $T_A = -40^\circ\text{C}$  to  $85^\circ\text{C}$**

Symbol	Parameter	Test Conditions	Minimum	Typical	Maximum	Units
$V_{DD}$	Supply Voltage		3.135	3.3	3.465	V
$I_{DD}$	Power Supply Current	No Load, OE = Low		135	150	mA

**Table 5B. Power Supply DC Characteristics,  $V_{DD} = 2.5V \pm 5\%$ ,  $T_A = -40^\circ\text{C}$  to  $85^\circ\text{C}$**

Symbol	Parameter	Test Conditions	Minimum	Typical	Maximum	Units
$V_{DD}$	Supply Voltage		2.375	2.5	2.625	V
$I_{DD}$	Power Supply Current	No Load, OE = Low		130	145	mA

**Table 5C. LVCMOS/LVTTL DC Characteristic,  $V_{DD} = 3.3V \pm 5\%$  or  $2.5V \pm 5\%$ ,  $T_A = -40^{\circ}C$  to  $85^{\circ}C$** 

Symbol	Parameter		Test Conditions	Minimum	Typical	Maximum	Units
$V_{IH}$	Input High Voltage	OE, SCLK, SDATA, FSEL[1:0]	$V_{DD} = 3.3V$	2		$V_{DD} + 0.3$	V
			$V_{DD} = 2.5V$	1.7		$V_{DD} + 0.3$	V
$V_{IL}$	Input Low Voltage	OE, SCLK, SDATA, FSEL[1:0]	$V_{DD} = 3.465V$	-0.3		0.8	V
			$V_{DD} = 2.5V$	-0.3		0.7	V
$I_{IH}$	Input High Current	OE,	$V_{DD} = V_{IN} = 3.465V$ or $2.625V$			10	$\mu A$
		SDATA, SCLK	$V_{DD} = V_{IN} = 3.465V$ or $2.625V$			5	$\mu A$
		FSEL0, FSEL1	$V_{DD} = V_{IN} = 3.465V$ or $2.625V$			150	$\mu A$
$I_{IL}$	Input Low Current	OE	$V_{DD} = 3.465V$ or $2.625V$ , $V_{IN} = 0V$	-500			$\mu A$
		SDATA, SCLK	$V_{DD} = 3.465V$ or $2.625V$ , $V_{IN} = 0V$	-150			$\mu A$
		FSEL0, FSEL1	$V_{DD} = 3.465V$ or $2.625V$ , $V_{IN} = 0V$	-5			$\mu A$
$V_{OH}$	Output High Voltage	Q	$V_{DD} = 3.465V$	2.4			V
			$V_{DD} = 2.625$	1.7			V
$V_{OL}$	Output Low Voltage	Q	$V_{DD} = 3.6V$ or $2.625$			0.4	V

## AC Electrical Characteristics

**Table 6A. AC Characteristics,  $V_{DD} = 3.3V \pm 5\%$  or  $2.5V \pm 5\%$ ,  $T_A = -40^\circ C$  to  $85^\circ C$**

Symbol	Parameter	Test Conditions	Minimum	Typical	Maximum	Units
$f_{OUT}$	Output Frequency Q, nQ	$P = 1, N = 10...126$	15.476		260	MHz
$f_I$	Initial Accuracy	Measured at $25^\circ C$ at Final Test			$\pm 10$	ppm
$f_S$	Temperature Stability	Option code = A or B			$\pm 100$	ppm
		Option code = E or F			$\pm 50$	ppm
		Option code = K or L			$\pm 20$	ppm
$f_A$	Aging	Frequency drift over 10 year life			$\pm 3$	ppm
		Frequency drift over 15 year life			$\pm 5$	ppm
$f_T$	Total Stability	Option code A or B (10 year life)			$\pm 113$	ppm
		Option code E or F (10 year life)			$\pm 63$	ppm
		Option code K or L (10 year life)			$\pm 33$	ppm
$f_{jit(cc)}$	Cycle-to-Cycle Jitter; NOTE 1	$V_{DD} = 3.3V$		15	32	ps
		$V_{DD} = 2.5V$		18	40	ps
$f_{jit(per)}$	Period Jitter; NOTE 1	$V_{DD} = 3.3V$		2.6	5	ps
		$V_{DD} = 2.5V$		4	7	ps
$f_{jit(\emptyset)}$	RMS Phase Jitter (Random)	$17MHz \leq f_{out} \leq 260MHz$ , Integration Range: 12kHz - 20MHz, NOTE 3		0.70	1.20	ps
		156.25MHz, Integration Range: 12kHz - 20MHz; NOTE 2		0.64	0.92	ps
		156.25MHz, Integration Range: 1kHz - 40MHz		0.85	1.00	ps
$\Phi_N(100)$	Single-side band phase noise, 100Hz from Carrier	156.25MHz		-75		dBc/Hz
$\Phi_N(1k)$	Single-side band phase noise, 1kHz from Carrier	156.25MHz		-98		dBc/Hz
$\Phi_N(10k)$	Single-side band phase noise, 10kHz from Carrier	156.25MHz		-118		dBc/Hz
$\Phi_N(100k)$	Single-side band phase noise, 100kHz from Carrier	156.25MHz		-127		dBc/Hz
$\Phi_N(1M)$	Single-side band phase noise, 1MHz from Carrier	156.25MHz		-139		dBc/Hz
$\Phi_N(10M)$	Single-side band phase noise, 10MHz from Carrier	156.25MHz		-143		dBc/Hz
$t_R / t_F$	Output Rise/Fall Time	$V_{DD} = 3.3V, 20\% \text{ to } 80\%$	150	425	700	ps
		$V_{DD} = 2.5V, 20\% \text{ to } 80\%$	150	500	800	ps
odc	Output Duty Cycle		45	50	55	%
$t_{OSC}$	Oscillator Start-Up Time				20	ms
$t_{SET}$	Output frequency settling time after FSEL0 and FSEL1 values are changed				1	ms

NOTE: Electrical parameters are guaranteed over the specified ambient operating temperature range, which is established when the device is mounted in a test socket with maintained transverse airflow greater than 500 lpm. The device will meet specifications after thermal equilibrium has been reached under these conditions.

NOTE: All AC parameters are characterized with  $P = 1$ .

NOTES continued on next page.



NOTE: Please see the FemtoClock Ceramic 5x7 Modules Programming Guide for more information on PLL feedback modes and the optimum configuration for phase noise.

NOTE 1: This parameter is defined in accordance with JEDEC standard 65.

NOTE 2: Please refer to the phase noise plots.

NOTE 3: Applies to output frequencies: 17MHz, 19.44MHz, 25MHz, 33.33MHz, 75MHz, 77.76MHz, 100MHz, 106.25MHz, 122.88MHz, 125MHz, 150MHz, 155.52MHz, 156.25MHz, 161.132MHz, 175MHz, 187.5MHz, 200MHz, 212.5MHz, 250MHz and 260MHz.

**Table 6B. VCXO Control Voltage Input ( $V_C$ ) Characteristics,**

Symbol	Parameter	Test Conditions	Minimum	Typical	Maximum	Units
$K_V$	Oscillator Gain, NOTE 1, 2, 3	$V_{DD} = 3.3V$	7.57		477.27	ppm/V
		$V_{DD} = 2.5V$	10		630	ppm/V
$L_{VC}$	Control Voltage Linearity; NOTE 4	BSL Variation	-5	$\pm 0.4$	+5	%
BW	Modulation Bandwidth			100		kHz
$Z_{VC}$	VC Input Impedance			500		$k\Omega$
$V_{C_{NOM}}$	Nominal Control Voltage			$V_{DD}/2$		V
$V_C$	Control Voltage Tuning Range; NOTE 4	$V_{DD} = 3.3V \pm 5\%$ or $2.5V \pm 5\%$ , $T_A = -40^\circ C$ to $85^\circ C$	0		$V_{DD}$	V

NOTE 1:  $V_C = 0V$  to  $V_{DD}$ . Oscillator gain is programmed by IDT. Gain =  $(25 \cdot n) \div V_{CC}$  and is in the range of  $n=1$  to  $n = 63$ .

NOTE 2: Nominal oscillator gain: Please refer to the FemtoClock NG Ceramic 5x7 Module Programming Guide document.

NOTE 3: For best phase noise performance, use the lowest  $K_V$  that meets the requirements of the application.

NOTE 4: BSL = Best Straight Line Fit: Variation of the output frequency vs. control voltage  $V_C$ , in percent.  $V_C$  ranges from 10% to 90%  $V_{DD}$ .

### Typical Phase Noise at 156.25MHz (12kHz - 20MHz)

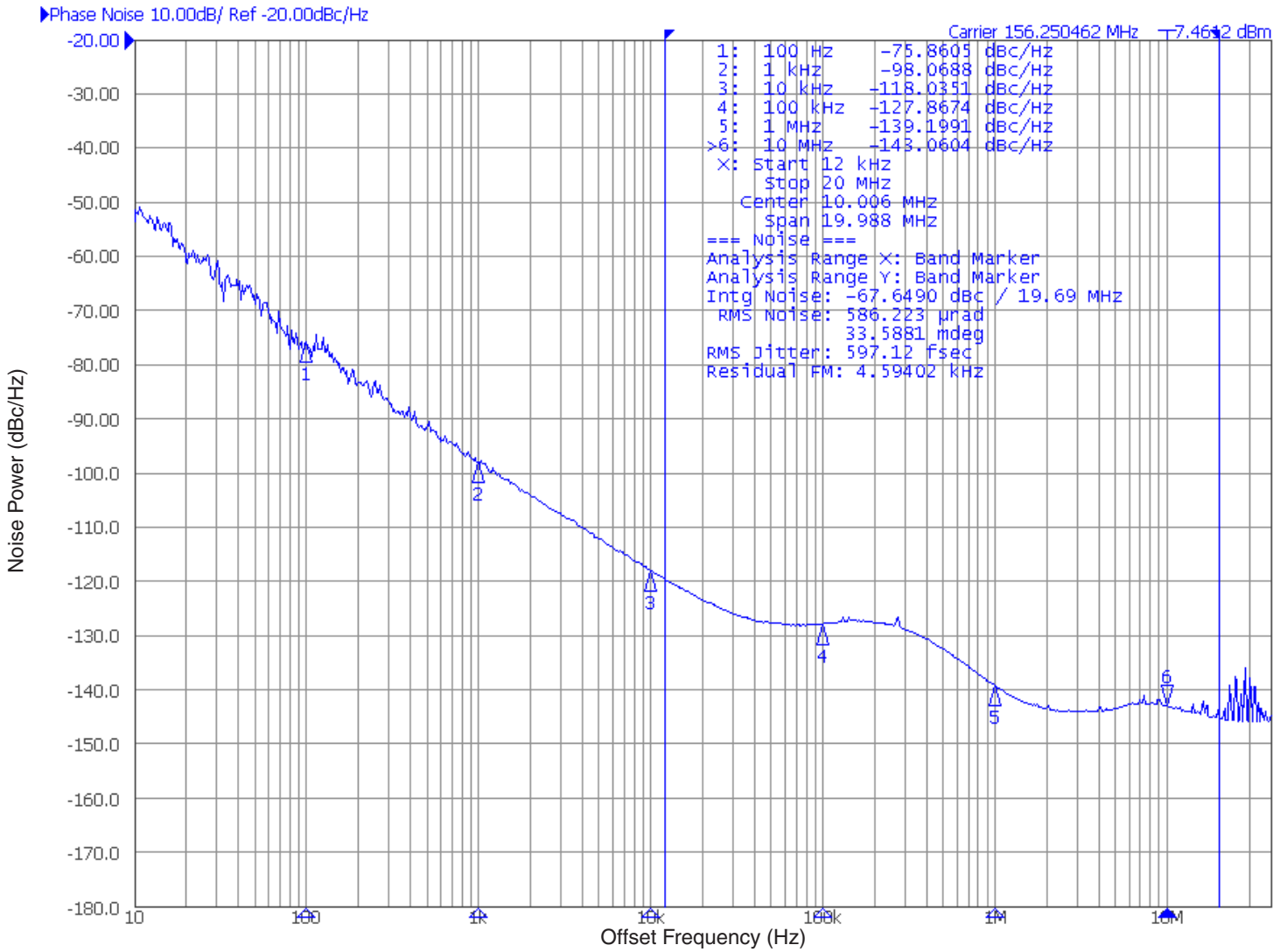

### Parameter Measurement Information

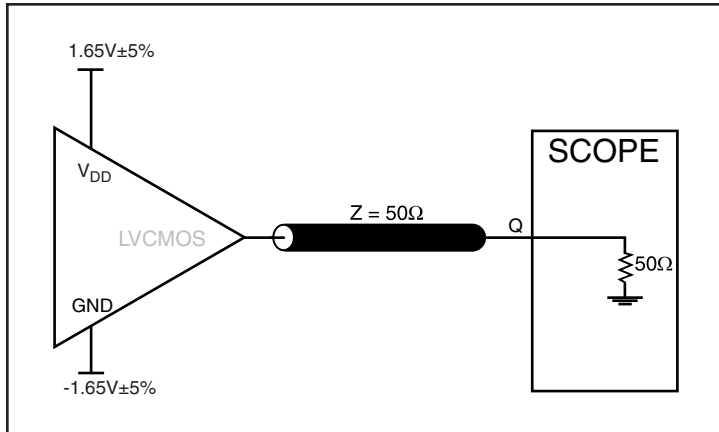

3.3V LVC MOS Output Load Test Circuit

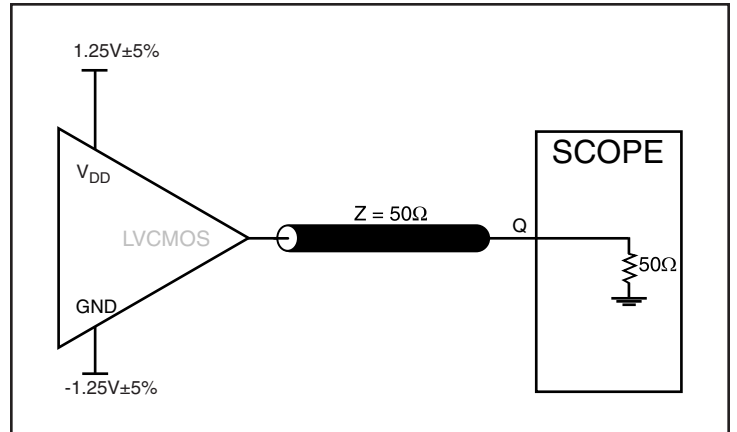

2.5V LVC MOS Output Load Test Circuit

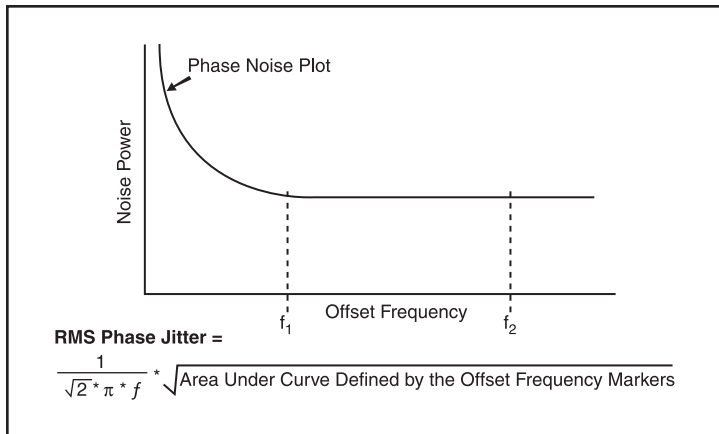

RMS Phase Jitter

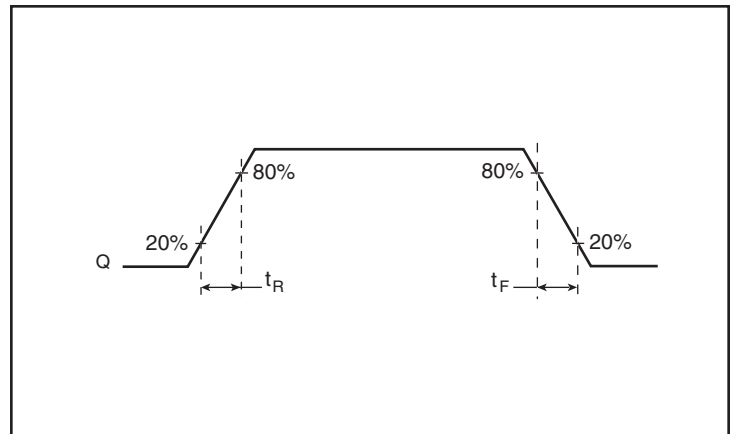

Output Rise/Fall Time

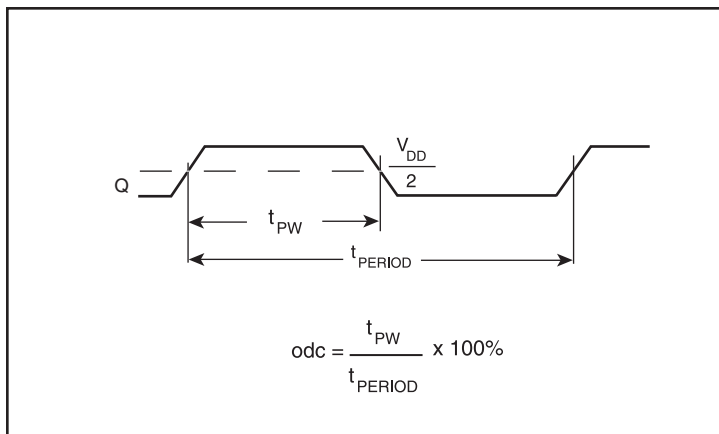

Output Duty Cycle/Pulse Width/Period

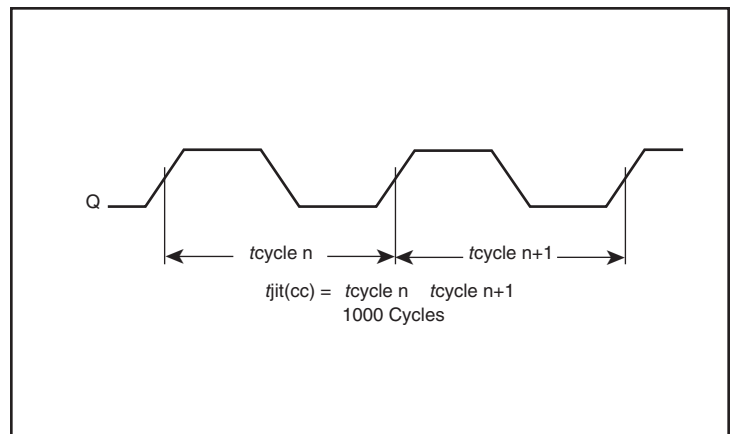

Cycle-to-Cycle Jitter

## Parameter Measurement Information, continued

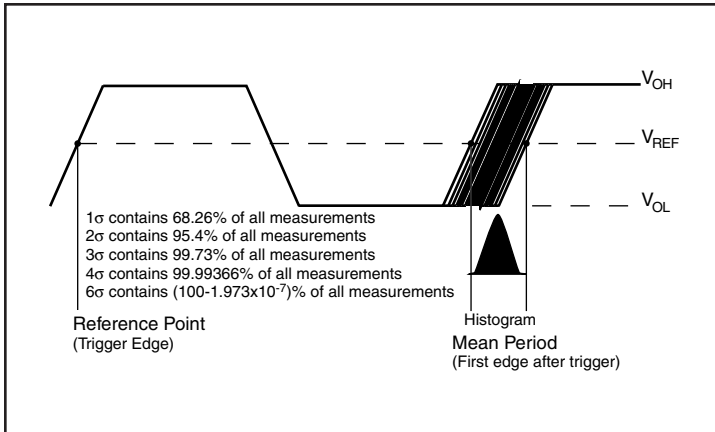

### Period Jitter

## Applications Information

### Recommendations for Unused Input Pins

#### Inputs:

##### LVC MOS Select Pins

All control pins have internal pullups or pulldowns; additional resistance is not required but can be added for additional protection. A  $1k\Omega$  resistor can be used.

### Schematic Example

Figure 1 shows an example 8N0QV01 application schematic in which the device is operated at  $V_{DD} = +3.3V$ . The schematic example focuses on functional connections and is intended as an example only and may not represent the exact user configuration. Refer to the pin description and functional tables in the datasheet to ensure the logic control inputs are properly set. For example OE and FSEL[1:0] can be configured from an FPGA instead of set with pull up and pull down resistors as shown.

The 8N0QV01 is not a self contained part; it requires pairing with a PLL. The two connections necessary to be made to the PLL are VC, the analog control voltage that sets the center frequency of the VCXO, and Q, which is the oscillator output. VC is the analog output of the PLL low pass loop filter that serves to remove noise from the phase detector error output.

As with any high speed analog circuitry, the power supply pins are vulnerable to random noise, so to achieve optimum jitter performance isolation of the  $V_{DD}$  pin from the power supply is required. In order to

achieve the best possible filtering, it is recommended that the placement of the filter components be on the device side of the PCB as close to the power pins as possible. If space is limited, the  $0.1\mu F$  capacitor on the  $V_{DD}$  pin must be placed on the device side with direct return to the ground plane though vias. The remaining filter components can be on the opposite side of the PCB.

Power supply filter component recommendations are a general guideline to be used for reducing external noise from coupling into the devices. The filter performance is designed for a wide range of noise frequencies. This low-pass filter starts to attenuate noise at approximately 10kHz. If a specific frequency noise component is known, such as switching power supplies frequencies, it is recommended that component values be adjusted and if required, additional filtering be added. Additionally, good general design practices for power plane voltage stability suggests adding bulk capacitance in the local area of all devices.

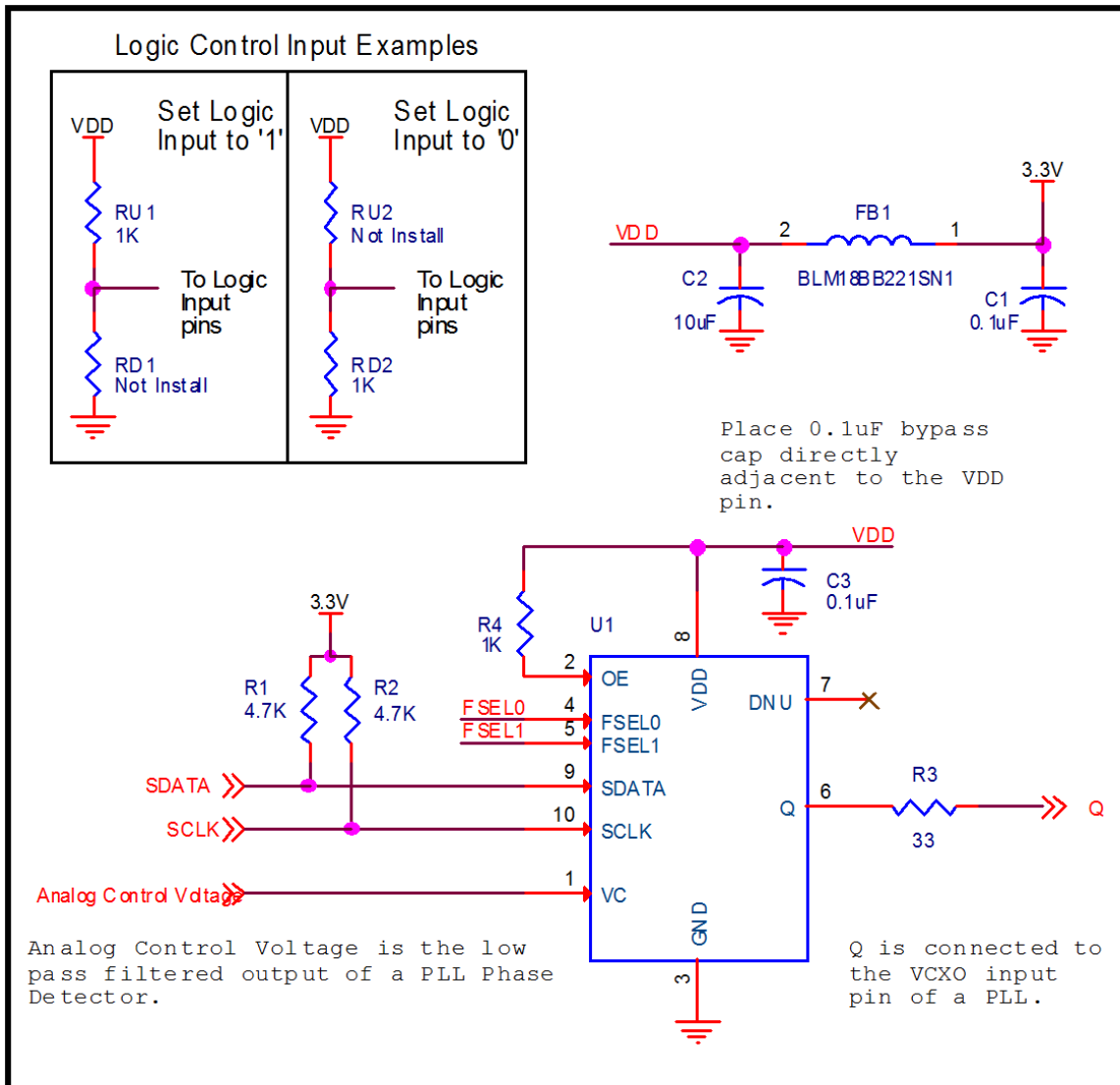

Figure 1. IDT8N0QV01 Schematic Example

## Power Considerations

This section provides information on power dissipation and junction temperature for the IDT8N0QV01. Equations and example calculations are also provided.

### 1. Power Dissipation.

The total power dissipation for the IDT8N0QV01 is the sum of the core power plus the power dissipation in the load(s). The following is the power dissipation for  $V_{DD} = 3.3V + 5\% = 3.465V$ , which gives worst case results.

- Power (core)<sub>MAX</sub> =  $V_{DD\_MAX} * I_{DD} = 3.465V * 150mA = 519.8mW$

#### Total Static Power:

$$= \text{Power (core)}_{MAX} = 519.8mW$$

#### Dynamic Power Dissipation at $F_{OUT}$ (max)

$$\text{Total Power (F}_{OUT\_MAX}) = [(C_{PD} * N) * \text{Frequency} * (V_{DD})^2] = [(8pF * 1) * 260MHz * (3.465V)^2] = 24.97mW$$

#### Total Power

$$\begin{aligned} &= \text{Static Power} + \text{Dynamic Power Dissipation} \\ &= 519.8mW + 24.97mW \\ &= 544.77mW \end{aligned}$$

### 2. Junction Temperature.

Junction temperature,  $T_j$ , is the temperature at the junction of the bond wire and bond pad, and directly affects the reliability of the device. The maximum recommended junction temperature is 125°C. Limiting the internal transistor junction temperature,  $T_j$ , to 125°C ensures that the bond wire and bond pad temperature remains below 125°C.

The equation for  $T_j$  is as follows:  $T_j = \theta_{JA} * Pd\_total + T_A$

$T_j$  = Junction Temperature

$\theta_{JA}$  = Junction-to-Ambient Thermal Resistance

$Pd\_total$  = Total Device Power Dissipation (example calculation is in section 1 above)

$T_A$  = Ambient Temperature

In order to calculate junction temperature, the appropriate junction-to-ambient thermal resistance  $\theta_{JA}$  must be used. Assuming no air flow and a multi-layer board, the appropriate value is 49.4°C/W per Table 7 below.

Therefore,  $T_j$  for an ambient temperature of 85°C with all outputs switching is:

$$85^\circ C + 0.545W * 49.4^\circ C/W = 112^\circ C. \text{ This is below the limit of } 125^\circ C.$$

This calculation is only an example.  $T_j$  will obviously vary depending on the number of loaded outputs, supply voltage, air flow and the type of board (multi-layer).

**Table 7. Thermal Resistance  $\theta_{JA}$  for a 10-lead Ceramic 5mm x 7mm Package, Forced Convection**

Meters per Second	$\theta_{JA}$ by Velocity		
	0	1	2.5
Multi-Layer PCB, JEDEC Standard Test Boards	49.4°C/W	44.2°C/W	41.0°C/W

## Reliability Information

**Table 8.  $\theta_{JA}$  vs. Air Flow Table for a 10-lead Ceramic 5mm x 7mm Package**

$\theta_{JA}$ vs. Air Flow			
Meters per Second	0	1	2.5
Multi-Layer PCB, JEDEC Standard Test Boards	49.4°C/W	44.2°C/W	41.0°C/W

## Transistor Count

The transistor count for IDT8N0QV01 is: 47,302





**Table 9. Device Marking**

Marking	Industrial Temperature Range ( $T_A = -40^{\circ}\text{C}$ to $85^{\circ}\text{C}$ )	Commercial Temperature Range ( $T_A = 0^{\circ}\text{C}$ to $70^{\circ}\text{C}$ )
		IDT8N0QV01yH- <b>ddddCDI</b>
<b>y</b> = Option Code, <b>dddd</b> =Default-Frequency and VCXO Pull Range		

NOTE: For available order codes, see the FemtoClock NG Ceramic-Package XO and VCXO Ordering Product Information document.

For more information and guidelines on programming of the device for custom frequency configurations, programming for a specific VCXO pull range, the available APR (absolute pull range), the register description and the serial interface description, see the FemtoClock NG Ceramic 5x7 Module Programming Guide.

## Revision History Sheet

Rev	Table	Page	Description of Change	Date
A	T1	3	first row: deleted '(see Table 3C).'	3/14/2014
			forth row: replaced description.	
	6A	8	Deleted NOTE 2 from RMS Phase Jitter. Added 'NOTE 2' to 156.25MHz.	
	6B	9	Note 2: Added 'Please refer to the FemtoClock NG Ceramic 5x7 Module Programming Guide document.'	
		14	Power Considerations. Changed Dynamic Power Dissipation from 2.5mW to 24.97mW	

## We've Got Your Timing Solution



6024 Silver Creek Valley Road  
San Jose, California 95138

**Sales**  
800-345-7015 (inside USA)  
+408-284-8200 (outside USA)  
Fax: 408-284-2775  
[www.IDT.com/go/contactIDT](http://www.IDT.com/go/contactIDT)

**Technical Support Sales**  
[netcom@idt.com](mailto:netcom@idt.com)  
+480-763-2056

DISCLAIMER Integrated Device Technology, Inc. (IDT) and its subsidiaries reserve the right to modify the products and/or specifications described herein at any time and at IDT's sole discretion. All information in this document, including descriptions of product features and performance, is subject to change without notice. Performance specifications and the operating parameters of the described products are determined in the independent state and are not guaranteed to perform the same way when installed in customer products. The information contained herein is provided without representation or warranty of any kind, whether express or implied, including, but not limited to, the suitability of IDT's products for any particular purpose, an implied warranty of merchantability, or non-infringement of the intellectual property rights of others. This document is presented only as a guide and does not convey any license under intellectual property rights of IDT or any third parties.

IDT's products are not intended for use in applications involving extreme environmental conditions or in life support systems or similar devices where the failure or malfunction of an IDT product can be reasonably expected to significantly affect the health or safety of users. Anyone using an IDT product in such a manner does so at their own risk, absent an express, written agreement by IDT.

Integrated Device Technology, IDT and the IDT logo are registered trademarks of IDT. Other trademarks and service marks used herein, including protected names, logos and designs, are the property of IDT or their respective third party owners.

Copyright 2013. All rights reserved.



Компания «ЭлектроПласт» предлагает заключение долгосрочных отношений при поставках импортных электронных компонентов на взаимовыгодных условиях!

Наши преимущества:

- Оперативные поставки широкого спектра электронных компонентов отечественного и импортного производства напрямую от производителей и с крупнейших мировых складов;
- Поставка более 17-ти миллионов наименований электронных компонентов;
- Поставка сложных, дефицитных, либо снятых с производства позиций;
- Оперативные сроки поставки под заказ (от 5 рабочих дней);
- Экспресс доставка в любую точку России;
- Техническая поддержка проекта, помощь в подборе аналогов, поставка прототипов;
- Система менеджмента качества сертифицирована по Международному стандарту ISO 9001;
- Лицензия ФСБ на осуществление работ с использованием сведений, составляющих государственную тайну;
- Поставка специализированных компонентов (Xilinx, Altera, Analog Devices, Intersil, Interpoint, Microsemi, Aeroflex, Peregrine, Syfer, Eurofarad, Texas Instrument, Miteq, Cobham, E2V, MA-COM, Hittite, Mini-Circuits, General Dynamics и др.);

Помимо этого, одним из направлений компании «ЭлектроПласт» является направление «Источники питания». Мы предлагаем Вам помощь Конструкторского отдела:

- Подбор оптимального решения, техническое обоснование при выборе компонента;
- Подбор аналогов;
- Консультации по применению компонента;
- Поставка образцов и прототипов;
- Техническая поддержка проекта;
- Защита от снятия компонента с производства.



#### Как с нами связаться

**Телефон:** 8 (812) 309 58 32 (многоканальный)

**Факс:** 8 (812) 320-02-42

**Электронная почта:** [org@eplast1.ru](mailto:org@eplast1.ru)

**Адрес:** 198099, г. Санкт-Петербург, ул. Калинина, дом 2, корпус 4, литера А.