

Helping Customers Innovate, Improve & Grow



Description

Vectron's VC-801 Crystal Oscillator (XO) is a quartz stabilized square wave generator with a CMOS output. The VC-801 uses fundamental or 3rd overtone crystals resulting in very low jitter performance, and a monolithic IC which improves reliability and reduces cost.

Features

- CMOS output XO
- Output Frequencies from 32.768kHz to 125.000MHz
- 5.0, 3.3, 2.5 or 1.8 V Operation
- Low Jitter Performance
- Output Disable Feature
- ± 20 ppm Frequency Stability Available
- Operating Temperature ranging from -55°C to $+125^{\circ}\text{C}$
- Small Industry Standard Package, 3.2 x 5.0 x 1.3mm
- Product is compliant to RoHS directive  and fully compatible with lead free assembly

Applications

- SONET/SDH/DWDM
- Ethernet, GE, SynchE
- Storage Area Networking
- Fiber Channel
- Digital Video
- Broadband Access
- Base Stations, Picocells

Block Diagram

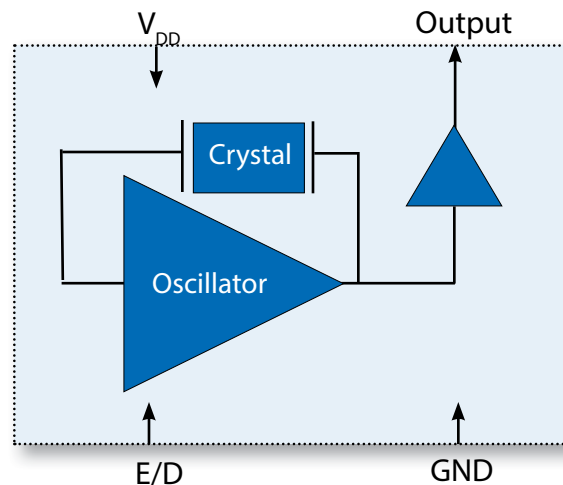

Specifications

Table 1. Electrical Performance, 5V Option

Parameter	Symbol	Min	Typical	Max	Units
Supply Voltage					
Voltage ¹	V_{DD}	4.5	5.0	5.5	V
Max Voltage		-0.7		7	V
Current ² ≤20.000MHz 20.001 to 50.000MHz 50.001 to 75.000MHz	I_{DD}			10 30 40	mA mA mA
Current, Output Disabled				30	uA
Frequency					
Nominal Frequency ³	f_N	1.544		75.000	MHz
Stability ^{4,8} (Ordering Option)		±20, ±25, ±32, ±50, ±100			ppm
Output					
Output Logic Levels ² Output Logic High Output Logic Low Output Logic High Drive Output Logic Low Drive	V_{OH} V_{OL} I_{OH} I_{OL}	0.9* V_{DD} 16 16		0.1* V_{DD}	V V mA mA
Load				15	pF
Output Rise /Fall Time ² <20.000MHz 20.000 to 50.000MHz 50.001 to 75.000MHz	t_R/t_F			8 5 2	ns ns ns
Output Leakage, Output Disabled	I_Z			±10	uA
Duty Cycle ^{2,5}		45	50	55	%
Period Jitter ⁶ RMS Peak-Peak	ϕ_J		3.0 21		ps ps
RMS Jitter, 12kHz-20MHz	ϕ_J		0.5	1	ps
Enable/Disable					
Output Enable/Disable ⁷ Output Enable Output Disable	V_{IH} V_{IL}	4.0		0.8	V V
Disable time	t_D			100	ns
Enable Internal Pull-Up Resistor			100		Kohm
Start-Up Time	t_{SU}			8	ms
Operating Temp (Ordering Option)	T_{OP}	-10/70, -20/70, -40/85, -40/105, -40/125, -55/105, -55/125			°C

- 1) The power supply should have by-pass capacitors as close to the supply and to ground as possible, for example 0.1 and 0.01uF.
- 2) Parameters are tested with the test circuit shown in Fig 1.
- 3) See Standard Frequencies and Ordering Information tables for more specific information.
- 4) Includes initial accuracy, operating temperature, supply voltage, shock and vibration (not under operation) and aging for ±50 and ±100ppm options.
- 5) Duty Cycle is measured as On Time/Period, see Fig 2.
- 6) Broadband Period Jitter measured using Wavecrest SIA3300C, 90K samples, see Application Note for Typical Phase Noise and Jitter Performance.
- 7) The Output is Enabled if the Enable/Disable is left open.
- 8) Only ±50 and ±100 stability option available for -40/105 °C, -40/125 °C, -55/105 °C and -55/125 °C Operating temperature range.

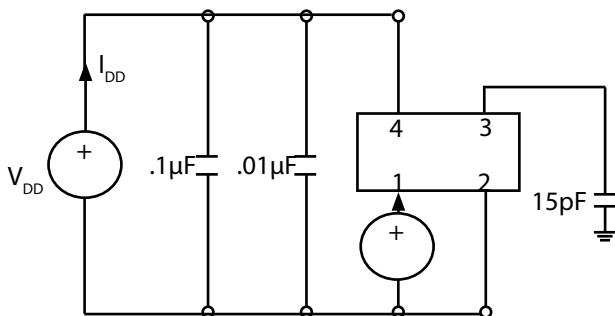

Fig 1: Test Circuit

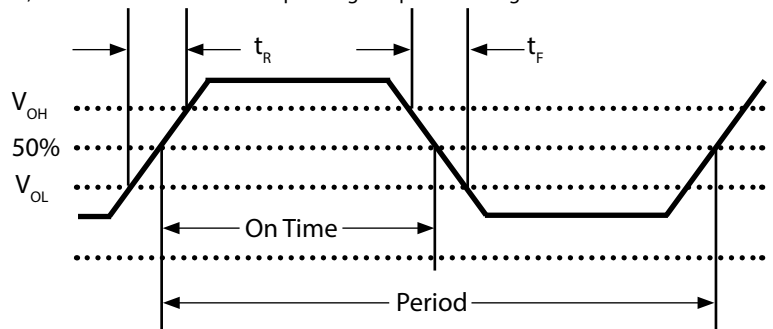

Fig 2: Waveform

Specifications

Table 2. Electrical Performance, 3.3V Option

Parameter	Symbol	Min	Typical	Max	Units
Supply Voltage					
Voltage ¹	V_{DD}	2.97	3.30	3.63	V
Max Voltage		-0.5		5.0	V
Current ² 32.768kHz to 1.499MHz 1.500 to 20.000 MHz 20.001 to 50.000MHz 50.001 to 100.000MHz 100.001 to 125.000MHz	I_{DD}			5 7 20 30 40	mA mA mA mA mA
Current, Output Disabled				30	uA
Frequency					
Nominal Frequency ³	f_N	0.032		125.000	MHz
Stability ^{4,8} (Ordering Option)		±20, ±25, ±32, ±50, ±100			ppm
Output					
Output Logic Levels ² Output Logic High Output Logic Low Output Logic High Drive Output Logic Low Drive	V_{OH} V_{OL} I_{OH} I_{OL}	$0.9 \cdot V_{DD}$ 8 8		$0.1 \cdot V_{DD}$	V V mA mA
Load				15	pF
Output Rise /Fall Time ² 32.768kHz to 345.6kHz 345.6kHz to 20.000MHz 20.001 to 50.000MHz 50.001 to 75.000MHz 75.001 to 125.000MHz	t_R/t_F			200 6 4 3 2	ns ns ns ns ns
Output Leakage, Output Disabled	I_z			±10	uA
Duty Cycle ^{2,5}		45	50	55	%
Period Jitter ⁶ RMS Peak-Peak	ϕ_J		3.0 21		ps ps
RMS Jitter, 12kHz-20MHz	ϕ_J		0.5	1	ps
Enable/Disable					
Output Enable/Disable ⁷ Output Enable Output Disable	V_{IH} V_{IL}	2.0		0.5	V V
Disable time	t_D			100	ns
Enable Internal Pull-Up Resistor			100		Kohm
Start-Up Time	t_{SU}			8	ms
Operating Temp (Ordering Option)	T_{OP}	-10/70, -20/70, -40/85, -40/105, -40/125, -55/105, -55/125			°C

- 1] The power supply should have by-pass capacitors as close to the supply and to ground as possible, for example 0.1 and 0.01uF.
- 2] Parameters are tested with the test circuit shown in Fig 1.
- 3] See Standard Frequencies and Ordering Information tables for more specific information.
- 4] Includes initial accuracy, operating temperature, supply voltage, shock and vibration (not under operation) and aging for ±50 and ±100ppm options.
- 5] Duty Cycle is measured as On Time/Period, see Fig 2.
- 6] Broadband Period Jitter measured using Wavecrest SIA3300C, 90K samples, see Application Note for Typical Phase Noise and Jitter Performance.
- 7] The Output is Enabled if the Enable/Disable is left open.
- 8] Only ±50 and ±100 stability option available for -40/105 °C, -40/125 °C, -55/105 °C and -55/125 °C Operating temperature range.

Specifications

Table 3. Electrical Performance, 2.5V Option

Parameter	Symbol	Min	Typical	Max	Units
Supply Voltage					
Voltage ¹	V _{DD}	2.25	2.50	2.75	V
Max Voltage		-0.5		5.0	V
Current ² 32.768kHz to 1.499MHz 1.500 to 20.000 MHz 20.001 to 50.000MHz 50.001 to 75.000MHz 75.001 to 100.000MHz 100.001 to 125.000MHz	I _{DD}			5 7 15 20 25 30	mA mA mA mA mA mA
Current, Output Disabled				30	uA
Frequency					
Nominal Frequency ³	f _N	0.032		125.000	MHz
Stability ^{4,9} (Ordering Option)		±20, ±25, ±32, ±50, ±100			ppm
Output					
Output Logic Levels ² Output Logic High Output Logic Low Output Logic High Drive Output Logic Low Drive Output Logic High Drive ⁸ Output Logic Low Drive ⁸	V _{OH} V _{OL} I _{OH} I _{OL} I _{OH} I _{OL}	0.9*V _{DD} 4 4 8 8		0.1*V _{DD}	V V mA mA mA mA
Load	I _{OUT}			15	pF
Output Rise /Fall Time ² 32.768kHz to 345.6kHz 345.6kHz to 20.000MHz 20.001 to 50.000MHz 50.001 to 75.000MHz 75.001 to 125.000MHz	t _R /t _F			200 6 5 3 2	ns ns ns ns ns
Output Leakage, Output Disabled	I _Z			±10	uA
Duty Cycle ^{2,5}		45	50	55	%
Period Jitter ⁶ RMS Peak-Peak	φ _J		3.0 21		ps ps
RMS Jitter, 12kHz-20MHz	φ _J		0.5	1	ps
Enable/Disable					
Output Enable/Disable ⁷ Output Enable Output Disable	V _{IH} V _{IL}	1.75		0.5	V V
Disable time	t _D			100	ns
Enable Internal Pull-Up Resistor			100		Kohm
Start-Up Time	t _{SU}			8	ms
Operating Temp (Ordering Option)	T _{OP}	-10/70, -20/70, -40/85, -40/105, -40/125, -55/105, -55/125			°C

- 1] The power supply should have by-pass capacitors as close to the supply and to ground as possible, for example 0.1 and 0.01uF.
- 2] Parameters are tested with the test circuit shown in Fig 1.
- 3] See Standard Frequencies and Ordering Information tables for more specific information.
- 4] Includes initial accuracy, operating temperature, supply voltage, shock and vibration (not under operation) and aging for ±50 and ±100ppm options.
- 5] Duty Cycle is measured as On Time/Period, see Fig 2.
- 6] Broadband Period Jitter measured using Wavcrest SIA3300C, 90K samples, see Application Note for Typical Phase Noise and Jitter Performance.
- 7] The Output is Enabled if the Enable/Disable is left open.
- 8] For 3rd overtone crystal designs.
- 9] Only ±50 and ±100 stability option available for -40/105 °C, -40/125 °C, -55/105 °C and -55/125 °C Operating temperature range.

Table 4. Electrical Performance, 1.8V Option

Parameter	Symbol	Min	Typical	Max	Units
Supply Voltage					
Voltage ¹	V_{DD}	1.71	1.80	1.89	V
Max Voltage		-0.5		3.6	V
Current ² 1.544 to 20.000 MHz 20.001 to 70.000MHz 70.001 to 100.000MHz 100.001 to 125.000MHz	I_{DD}			5 15 20 25	mA mA mA mA
Current, Output Disabled				30	uA
Frequency					
Nominal Frequency ³	f_N	1.544		125.000	MHz
Stability ^{4,9} (Ordering Option)		$\pm 20, \pm 25, \pm 32, \pm 50, \pm 100$			ppm
Output					
Output Logic Levels ² Output Logic High Output Logic Low Output Logic High Drive Output Logic Low Drive Output Logic High Drive ⁸ Output Logic Low Drive ⁸	V_{OH} V_{OL} I_{OH} I_{OL} I_{OH} I_{OL}	$0.9 * V_{DD}$ 2.8 2.8 8 8		$0.1 * V_{DD}$	V V mA mA mA mA
Load				15	pF
Output Rise /Fall Time ² 1.544 to 20.000MHz 20.001 to 50.000MHz 50.001 to 125.000MHz	t_R/t_F			6 5 3	ns ns ns
Output Leakage, Output Disabled	I_Z			± 10	uA
Duty Cycle ^{2,5}		45	50	55	%
Period Jitter ⁶ RMS Peak-Peak	ϕJ		3.0 21		ps ps
RMS Jitter, 12kHz-20MHz	ϕJ		0.5	1	ps
Enable/Disable					
Output Enable/Disable ⁷ Output Enable Output Disable	V_{IH} V_{IL}	1.26		0.5	V V
Disable time	t_D			100	ns
Enable Internal Pull-Up Resistor			1		Mohm
Start-Up Time	t_{SU}			8	ms
Operating Temp (Ordering Option)	T_{OP}	-10/70, -20/70, -40/85, -40/105, -40/125, -55/105, -55/125			°C

1] The power supply should have by-pass capacitors as close to the supply and to ground as possible, for example 0.1 and 0.01uF.

2] Parameters are tested with the test circuit shown in Fig 1.

3] See Standard Frequencies and Ordering Information tables for more specific information.

4] Includes initial accuracy, operating temperature, supply voltage, shock and vibration (not under operation) and aging for ± 50 and ± 100 ppm options.

5] Duty Cycle is measured as On Time/Period, see Fig 2.

6] Broadband Period Jitter measured using Wavecrest SIA3300C, 90K samples, see Application Note for Typical Phase Noise and Jitter Performance.

7] The Output is Enabled if the Enable/Disable is left open.

8] For 3rd overtone crystal designs.

9] Only ± 50 and ± 100 stability option available for -40/105 °C, -40/125 °C, -55/105 °C and -55/125 °C Operating temperature range.

Outline Drawing & Pad Layout

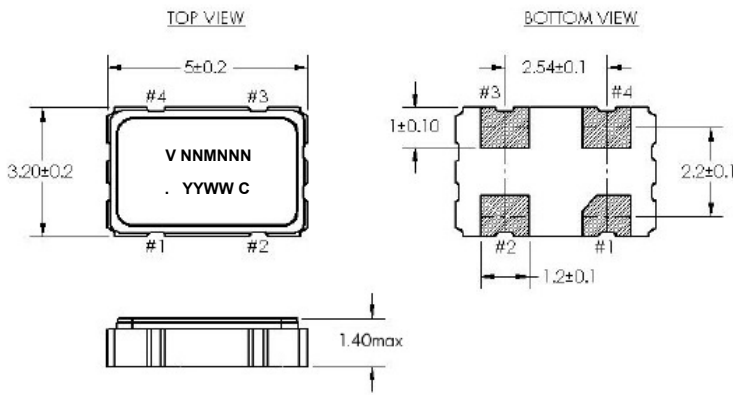

All dimensions in mm

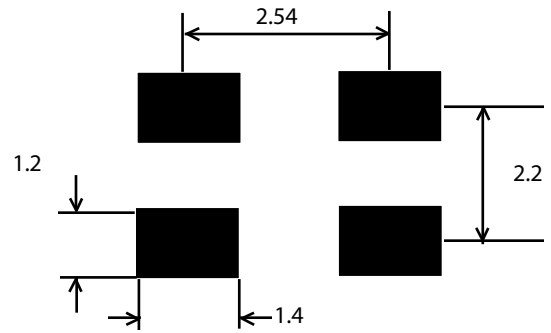

Table 5. Pin Out

Pin	Symbol	Function
1	E/D	Enable Disable
2	GND	Case and Electrical Ground
3	Output	Output
4	V _{DD}	Power Supply Voltage

Reliability

Vectron qualification includes aging at various extreme temperatures, shock and vibration, temperature cycling, and IR reflow simulation. The VC-801 family is capable of meeting the following qualification tests:

Table 6. Environmental Compliance

Parameter	Conditions
Mechanical Shock	MIL-STD-883, Method 2002
Mechanical Vibration	MIL-STD-883, Method 2007
Solderability	MIL-STD-883, Method 2003
Gross and Fine Leak	MIL-STD-883, Method 1014
Resistance to Solvents	MIL-STD-883, Method 2015
Moisture Sensitivity Level	MSL 1
Contact Pads	Gold (0.3 um min 1.0 um max) over Nickel
Weight	62 mg

Although ESD protection circuitry has been designed into the VC-801 proper precautions should be taken when handling and mounting. Vectron employs a human body model (HBM) and a charged device model (CDM) for ESD susceptibility testing and design protection evaluation.

Table 7. ESD Ratings

Model	Minimum	Conditions
Human Body Model	1500V	MIL-STD-883, Method 3015
Charged Device Model	1000V	JESD22-C101

Stresses in excess of the absolute maximum ratings can permanently damage the device. Functional operation is not implied at these or any other conditions in excess of conditions represented in the operational sections of this datasheet. Exposure to absolute maximum ratings for extended periods may adversely affect device reliability. Permanent damage is also possible if E/D is applied before V_{DD}.

Table 8. Absolute Maximum Ratings

Parameter	Symbol	Ratings	Unit
Storage Temperature	T _S	-55 to 125	°C
Soldering Temp/Time	T _{LS}	260 / 30	°C / sec

IR Reflow

Solderprofile:

The VC-801 is qualified to meet the JEDEC standard for Pb-Free assembly. The temperatures and time intervals listed are based on the Pb-Free small body requirements. The VC-801 device is hermetically sealed so an aqueous wash is not an issue.

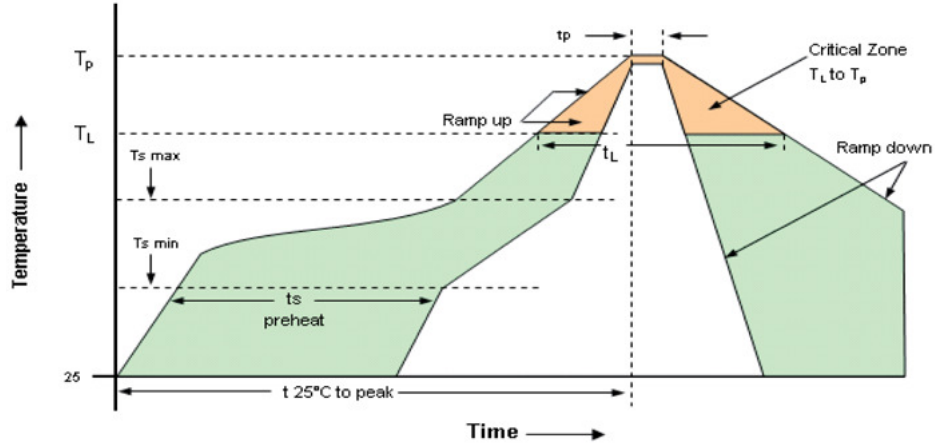

Table 9. Reflow Profile

Parameter	Symbol	Value
PreHeat Time T _s -min T _s -max	t _s	60 sec Min, 260 sec Max 150°C 200°C
Ramp Up	R _{UP}	3 °C/sec Max
Time Above 217 °C	t _L	60 sec Min, 150 sec Max
Time To Peak Temperature	T _{AMB-P}	480 sec Max
Time at 260 °C	t _p	30 sec Max
Ramp Down	R _{DN}	6 °C/sec Max

Tape and Reel

Table 10 . Tape and Reel Dimensions

Tape Dimensions (mm)						Reel Dimensions (mm)							# Per Reel
Dimension	W	F	Do	Po	P1	A	B	C	D	N	W1	W2	
Tolerance	Typ	Typ	Typ	Typ	Typ	Typ	Min	Typ	Min	Min	Typ	Max	
VC-801	16	7.5	1.5	4	8	180	2	13	21	60	17	21	1000

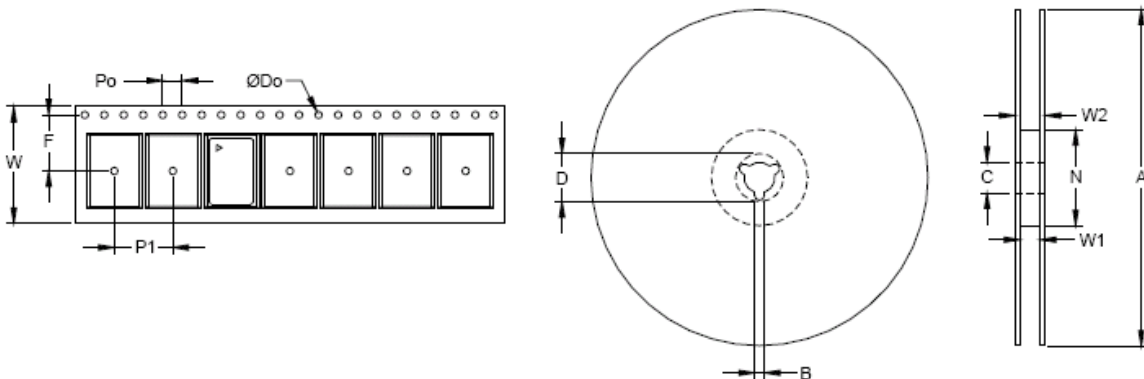
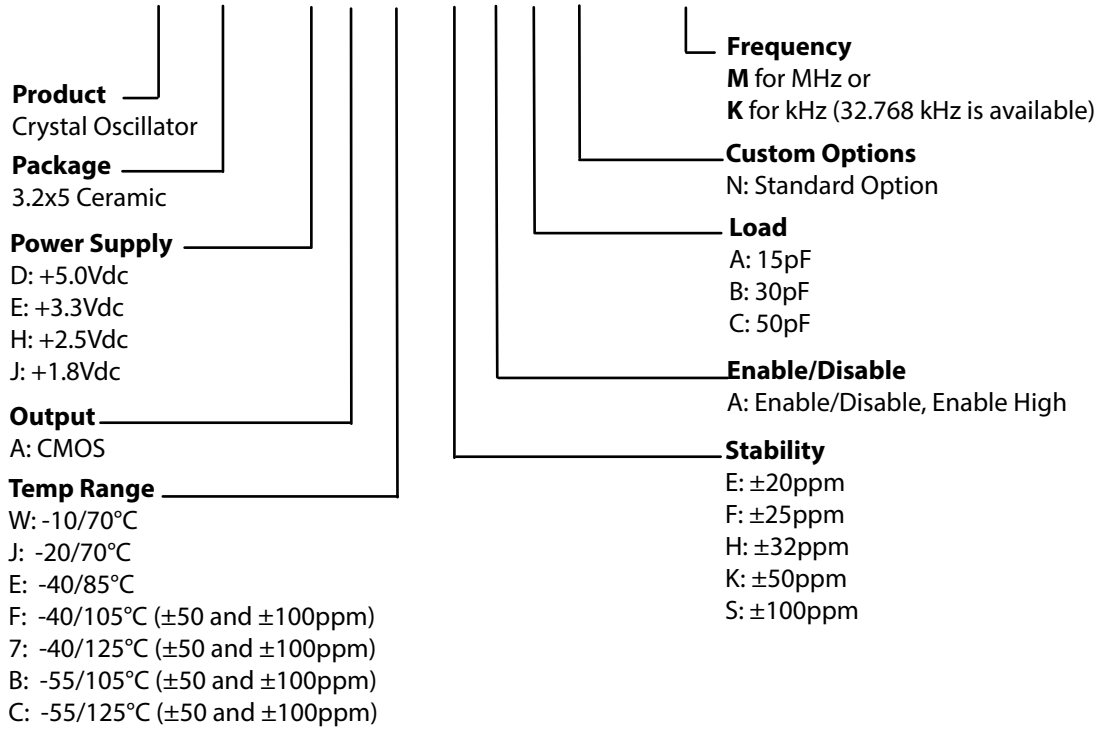

Table 11. Standard Output Frequencies (MHz)

9.8304	10.000	11.0590	11.0596	11.2896	12.000	12.272	12.288
12.353	13.000	13.500	13.560	14.318	14.7456	16.000	16.376
16.384	16.777216	16.800	17.734	17.734475	18.432	19.440	19.660
19.800	20.000	20.480	22.000	22.5792	24.000	24.5453	24.576
25.000	26.000	27.000	27,120	28.686	28.375	30.000	32.000
32.768	33.000	33.333	34.368	36.000	37.056	47.500	40.000
42.500	44.000	44.736	48.000	48.090	50.000	54.000	60.000
62.500	66.000	66.666	75.000	80.000	100.000	125.000	

Ordering Information

VC-801- E A W- K A A N- xxMxxxxxxx



Example: VC-801-EAW-KAAN-125M000000

**Note: not all combination of options are available. Other specifications may be available upon request. Please consult with factory.*

*** Add SNPB for tin lead solder dip**

Example: VC-801-EAW-KAAN-125M000000_SNPB

Revision History

Revision Date	Approved	Description
October 17, 2014	VN	Modified package drawing to reflect 1.40mm maximum height. Added Revision History Table.
January 20, 2015	VN	Included ordering options for -40/105°C, -40/125°C and -55/105°C Operating temperature ranges
August 10, 2018	FB	Update logo and ordering information, Add SNPB DIP ordering information,
March 22, 2019	FB	Update logo, contact information, disclaimer, change SNPB DIP to SNPB, add weight and gold plating thickness.

Contact Information

USA:

100 Watts Street
Mt Holly Springs, PA 17065
Tel: 1.717.486.3411
Fax: 1.717.486.5920

Europe:

Landstrasse
74924 Neckarbischofsheim
Germany
Tel: +49 (0) 7268.801.0
Fax: +49 (0) 7268.801.281



Information contained in this publication regarding device applications and the like is provided only for your convenience and may be superseded by updates. It is your responsibility to ensure that your application meets with your specifications. MICROCHIP MAKES NO REPRESENTATION OR WARRANTIES OF ANY KIND WHETHER EXPRESS OR IMPLIED, WRITTEN OR ORAL, STATUTORY OR OTHERWISE, RELATED TO THE INFORMATION INCLUDING, BUT NOT LIMITED TO ITS CONDITION, QUALITY, PERFORMANCE, MERCHANTABILITY OR FITNESS FOR PURPOSE. Microchip disclaims all liability arising from this information and its use. Use of Microchip devices in life support and/or safety applications is entirely at the buyer's risk, and the buyer agrees to defend, indemnify and hold harmless Microchip from any and all damages, claims, suits, or expenses resulting from such use. No licenses are conveyed, implicitly, or otherwise, under any Microchip intellectual property rights unless otherwise stated.

Trademarks

The Microchip and Vectron names and logos are registered trademarks of Microchip Technology Incorporated in the U.S.A. and other countries.



Компания «ЭлектроПласт» предлагает заключение долгосрочных отношений при поставках импортных электронных компонентов на взаимовыгодных условиях!

Наши преимущества:

- Оперативные поставки широкого спектра электронных компонентов отечественного и импортного производства напрямую от производителей и с крупнейших мировых складов;
- Поставка более 17-ти миллионов наименований электронных компонентов;
- Поставка сложных, дефицитных, либо снятых с производства позиций;
- Оперативные сроки поставки под заказ (от 5 рабочих дней);
- Экспресс доставка в любую точку России;
- Техническая поддержка проекта, помощь в подборе аналогов, поставка прототипов;
- Система менеджмента качества сертифицирована по Международному стандарту ISO 9001;
- Лицензия ФСБ на осуществление работ с использованием сведений, составляющих государственную тайну;
- Поставка специализированных компонентов (Xilinx, Altera, Analog Devices, Intersil, Interpoint, Microsemi, Aeroflex, Peregrine, Syfer, Eurofarad, Texas Instrument, Miteq, Cobham, E2V, MA-COM, Hittite, Mini-Circuits, General Dynamics и др.);

Помимо этого, одним из направлений компании «ЭлектроПласт» является направление «Источники питания». Мы предлагаем Вам помощь Конструкторского отдела:

- Подбор оптимального решения, техническое обоснование при выборе компонента;
- Подбор аналогов;
- Консультации по применению компонента;
- Поставка образцов и прототипов;
- Техническая поддержка проекта;
- Защита от снятия компонента с производства.



Как с нами связаться

Телефон: 8 (812) 309 58 32 (многоканальный)

Факс: 8 (812) 320-02-42

Электронная почта: org@eplast1.ru

Адрес: 198099, г. Санкт-Петербург, ул. Калинина, дом 2, корпус 4, литера А.