

NOTES:

- DRAWING TO BE INTERPRETED IN ACCORDANCE WITH THE CURRENT REVISION OF ASME Y14.5.
- THIS PART/PRODUCT IS TO BE MANUFACTURED WITH THE LATEST APPLICABLE REGULATIONS OF EC DIRECTIVES FOR THE RESTRICTION OF THE USE OF HAZARDOUS SUBSTANCES IN ELECTRICAL AND ELECTRONIC EQUIPMENT (ROHS), WASTE ELECTRICAL AND ELECTRONIC EQUIPMENT (WEEE) AND REGISTRATION, EVALUATION, AUTHORIZATION AND RESTRICTION OF CHEMICALS (REACH).
- OUTPUTS ARE FROM THE CENTER TO THE FULL TRAVEL POSITION.  
 OPTIONS "AA", "BB", "CC", "DD", "EE", "FF" PROVIDE INCREASED VOLTAGE IN +Y; AND DECREASING VOLTAGE IN -Y DIRECTION FROM ONE OUTPUT PER AXIS.  
 OPTIONS "GG" AND "HH" PROVIDE INCREASING VOLTAGES IN ALL DIRECTIONS (+Y, -Y) FROM 2 OUTPUTS PER AXIS.
- OPTIONS "BB" AND "EE" PROVIDE REDUNDANT OUTPUT 2 WHICH DUPLICATES OUTPUT 1.  
 OPTIONS "CC" AND "FF" PROVIDE REDUNDANT OUTPUT 2 WHICH IS INVERSE OF OUTPUT 1.
- SEE PAGE 3 FOR ALTERNATE BUTTON DESIGN. ONLY BUTTON STYLE "2", "5", AND "6" ARE OFFERED WITH A WATERTIGHT PANEL SEAL.
- MARKING TO INCLUDE: "OTTO" P/N & DATE CODE "YYWW".

# HTL2-

REV	OCN #	DATE	APR
A	044213	17 JUL 08	LBG
B	046891	19 JAN 09	LBG
C	063013	19 SEP 11	DCF
D	063582	28 OCT 11	KLW
E	066712	27 JUL 12	DCF
F	070736	31 MAY 13	DCF
G	071505	08 AUG 13	DCF

- 5** BUTTON STYLE
  - 1 = CASTLE
  - 2 = EXTERNAL CASTLE BOOT
  - 3 = SHORT DOUBLE STADIUM
  - 4 = TALL CONCAVE STADIUM
  - 5 = EXTERNAL BAT HANDLE BOOT
  - 6 = EXTERNAL SMOOTH BOOT
  - 7 = LONG CONCAVE Y AXIS BUTTON
- CASE STYLE**
  - 1 = .970 SQ.
- 5** SEAL
  - 1 = DUSTTIGHT
  - 2 = WATERTIGHT
- TRAVEL**
  - 1 = 25 DEGREES
- GATING**
  - 1. SINGLE AXIS
- OPERATE FORCE**
  - 1 = 16 OZ
- OUTPUT 1** **3**
  - AA = 2.5+/-2.0 VDC
  - BB = 2.5+/-2.0 VDC
  - CC = 2.5+/-2.0 VDC
  - DD = 2.5+/-1.5 VDC
  - EE = 2.5+/-1.5 VDC
  - FF = 2.5+/-1.5 VDC
  - GG = 0.5-4.5 VDC
  - HH = 1-4 VDC
- OUTPUT 2** **4**
  - NONE
  - 2.5+/-2.0 VDC
  - 2.5+/-2.0 VDC
  - NONE
  - 2.5+/-1.5 VDC
  - 2.5+/-1.5 VDC
  - 0.5-4.5 VDC
  - 1-4 VDC
- TERMINATION**
  - 1 = WIRE LEADS, 22 AWG, UL1569
  - 2 = PINS
  - 3 = WIRE LEADS, 24 AWG, SAE AS22759
- BUTTON COLOR**
  - 2 = BLACK

## PRODUCT SPECIFICATIONS

### ELECTRICAL:

RATED AT V <sub>cc</sub> = 5V @ 20°C LOAD = 1ma (4.7KΩ)	UNITS	MIN	TYP	MAX
SUPPLY VOLTAGE, V <sub>cc</sub>	VDC	4.50	5.00	5.50
OUTPUT VOLTAGE TOLERANCE AT CENTER (SEE APPROPRIATE GRAPH FOR OUTPUT VALUES)	VDC @5V V <sub>cc</sub>	-.25	NA	+.25
OUTPUT VOLTAGE TOLERANCE FULL TRAVEL (SEE APPROPRIATE GRAPH FOR OUTPUT VALUES)	VDC @5V V <sub>cc</sub>	-.25	NA	+.25
SUPPLY CURRENT PER SENSOR B=0, V <sub>cc</sub> =5V, I <sub>out</sub> =0	mA	NA	NA	10.0
OUTPUT SOURCE CURRENT LIMIT B=X*, V <sub>o</sub> =0	mA	-1.00	NA	1.00
OUTPUT RESISTANCE I <sub>o</sub> < -2 mA	Ω	NA	1.00	10.00

### MECHANICAL:

MECHANICAL LIFE ALL DIRECTIONS	1,000,000 CYCLES			
TRAVEL ANGLE	DEGREES	23	25	27
OPERATING FORCE (W/BOOT) AT TOP OF BUTTON, @ 20°C	OZ	NA	16	20
MAX. ALLOWABLE VERTICAL FORCE ON BUTTON	LBS	NA	NA	25
MAX. ALLOWABLE RADIAL FORCE ON BUTTON	LBS	NA	NA	25
MAX. ALLOWABLE TORQUE ON BUTTON ABOUT SHAFT AXIS	IN-LBS	NA	NA	5.5

### ENVIRONMENTAL:

OPERATING TEMPERATURE	°C	-40	20	85
ELECTRONICS SEAL INTEGRITY	WATERTIGHT PER IP68S, 1 METER			
EMI/RFI WITHSTAND	PER SAE J1113 CONTACT FACTORY FOR DETAILS			

### MATERIAL:

BOOT	ELASTOMER, BLACK
BUTTON	THERMOPLASTIC, BLACK
CASE	THERMOPLASTIC, BLACK
FLANGE	THERMOPLASTIC, BLACK
HARDWARE	4X ITW FASTEX PANEL FASTENER P/N 36030002, OR EQUIVALENT

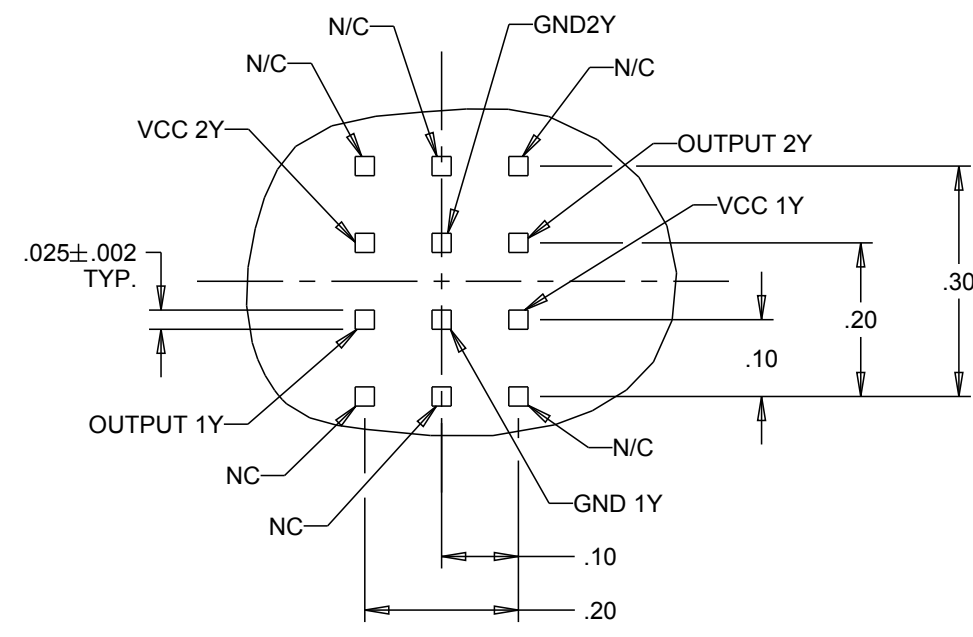
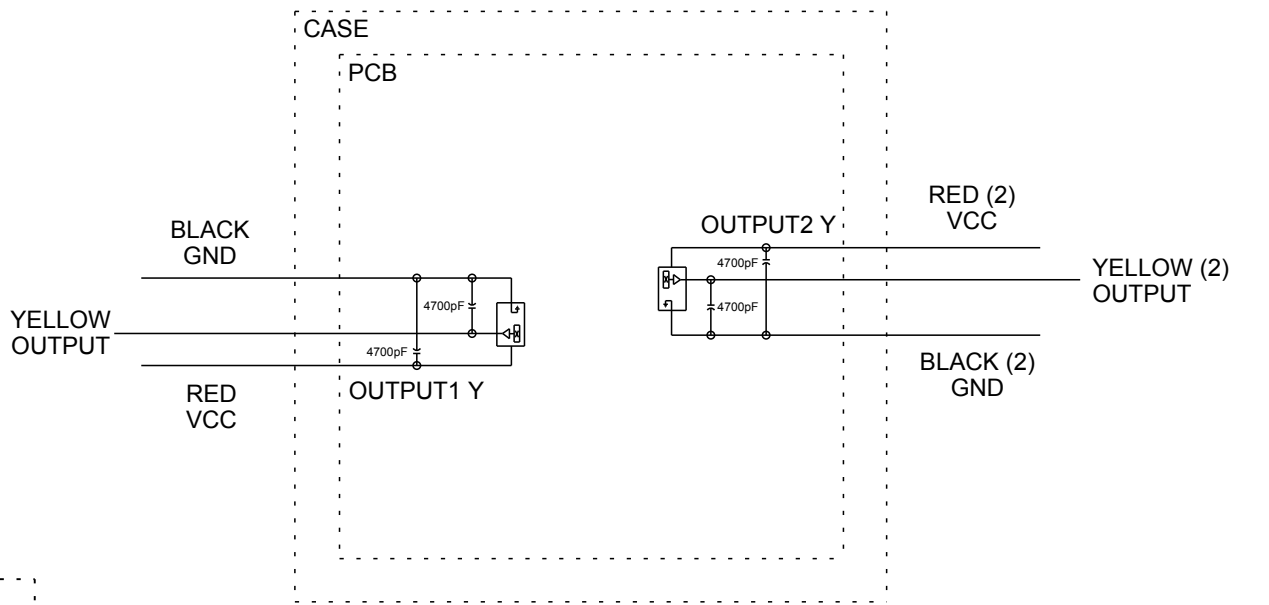
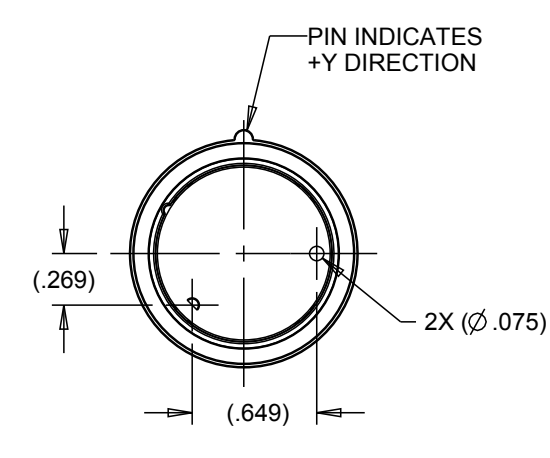
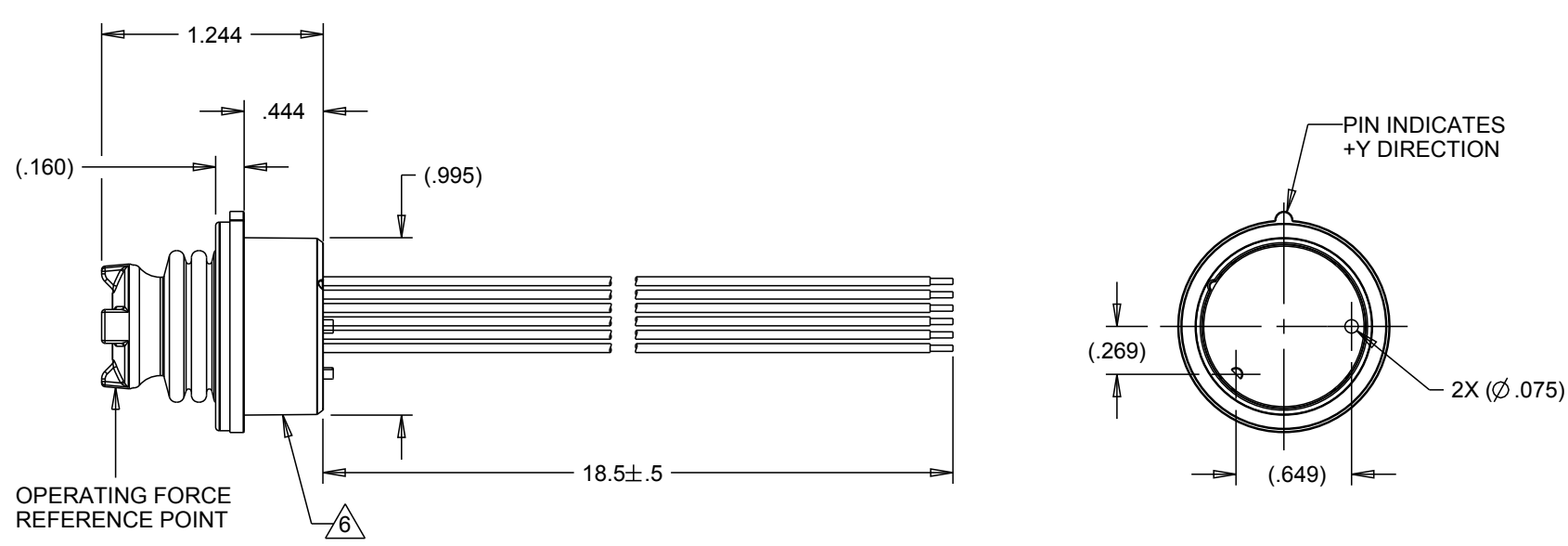
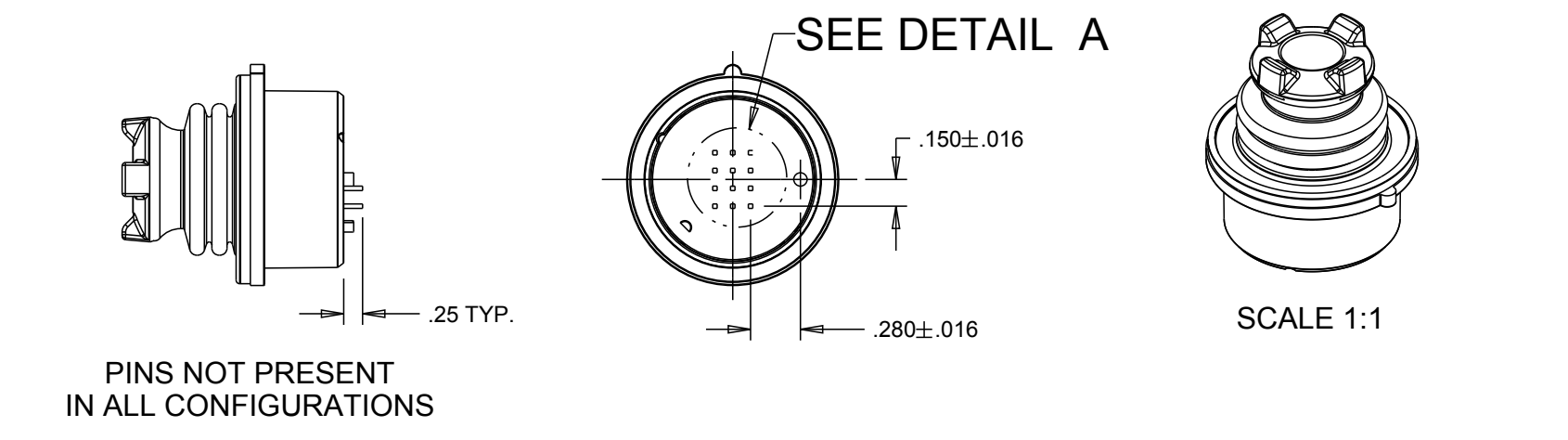
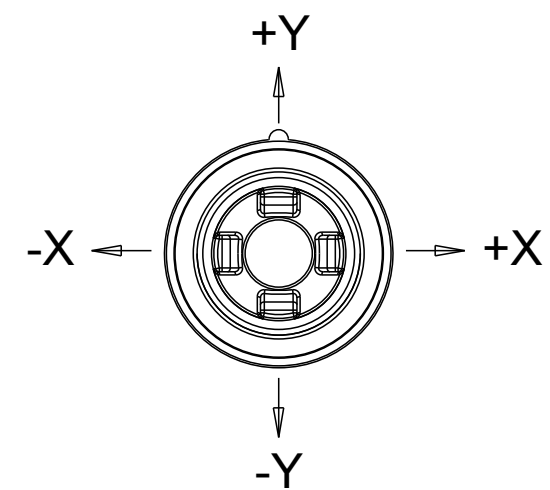

### DETAIL A

SCALE 4:1  
ALL PINS NOT PRESENT IN ALL CONFIGURATIONS

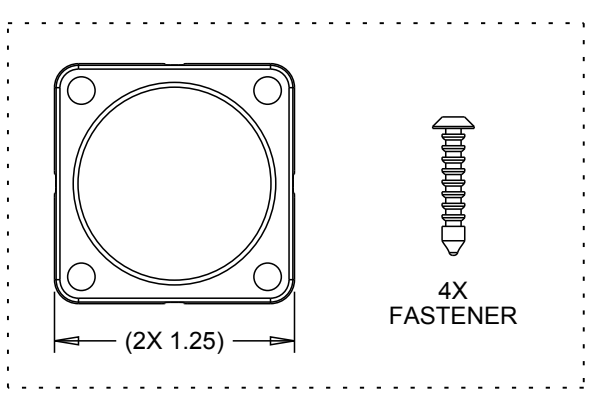
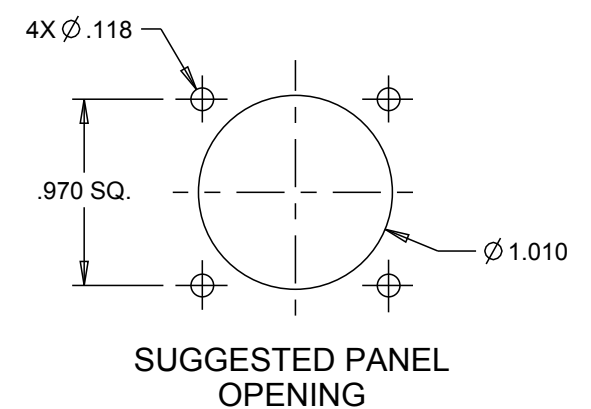

ALL WIRES NOT PRESENT IN ALL CONFIGURATIONS  
OUTPUT2 NOT PRESENT IN ALL CONFIGURATIONS

UNLESS OTHERWISE SPECIFIED: DIMENSIONS ARE IN INCHES.  
TOLERANCES:  
.XX ±.03  
.XXX ±.010  
ANGLES ±2°  
DO NOT SCALE



DESCRIPTION		HTL2, LINEAR HALL EFFECT		2-WAY TOGGLE	
DRWN. JLW	SIZE C	FSCM NO 21649	DRAWING NO. HTL2-	REV. G	
CHKD. MRM					
APPD. AH					
THIRD ANGLE PROJECTION			Scale 1:1	Sheet 1 OF 4	

THIS DOCUMENT IS THE CONFIDENTIAL PROPERTY OF OTTO ENGINEERING, INC.. IT IS NOT TO BE USED IN ANY WAY DETRIMENTAL TO THE INTERESTS OF OTTO ENGINEERING, INC..

### OPTION AA

### OPTION BB

### OPTION CC



### OPTION DD

### OPTION EE

### OPTION FF



### OPTION GG

### OPTION HH



UNLESS OTHERWISE SPECIFIED  
DIMENSIONS ARE IN INCHES.  
TOLERANCES ARE AS LISTED.  
MUST BE FREE FROM BURRS  
AND SHARP EDGES

TOLERANCES  
.XX ±.03  
.XXX ±.010  
ANGLES ±2°  
DO NOT SCALE DRAWING

THIS DOCUMENT IS THE CONFIDENTIAL  
PROPERTY OF OTTO ENGINEERING, INC..  
IT IS NOT TO BE USED IN ANY WAY  
DETRIMENTAL TO THE INTERESTS  
OF OTTO ENGINEERING, INC.

DRWN. JLW  
CHKD. MRM  
APPD. AH  
WT.

SIZE  
**C**

FSCM NO  
**21649**

DRAWING NO.  
**HTL2-**

REV.  
**G**

THIRD ANGLE  
PROJECTION

Scale 1:1

Sheet 2 OF 4

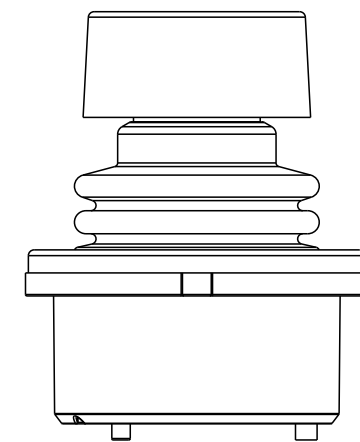
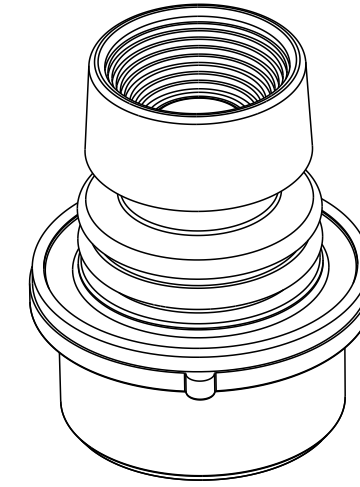

BUTTON STYLE 1  
(CASTLE)

BUTTON STYLE 2  
(EXTERNAL CASTLE BOOT)

BUTTON STYLE 3  
(SHORT DOUBLE STADIUM)

BUTTON STYLE 4  
(TALL CONCAVE STADIUM)

BUTTON STYLE CONFIGURATION

UNLESS OTHERWISE SPECIFIED DIMENSIONS ARE IN INCHES. TOLERANCES ARE AS LISTED. MUST BE FREE FROM BURRS AND SHARP EDGES	TOLERANCES		THIS DOCUMENT IS THE CONFIDENTIAL PROPERTY OF OTTO ENGINEERING, INC.. IT IS NOT TO BE USED IN ANY WAY DETRIMENTAL TO THE INTERESTS OF OTTO ENGINEERING, INC.	DRWN. JLW	SIZE	FSCM NO	DRAWING NO.	REV.
	.XX	±.03		CHKD. DCF	C	21649	HTL2-_____	G
	.XXX	±.010		APPD. AH				
ANGLES ±2° DO NOT SCALE DRAWING			WT.	THIRD ANGLE PROJECTION	Scale 1:1	Sheet 3 OF 4		

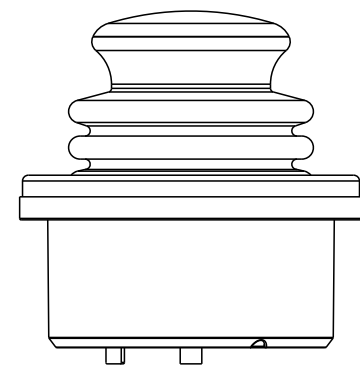
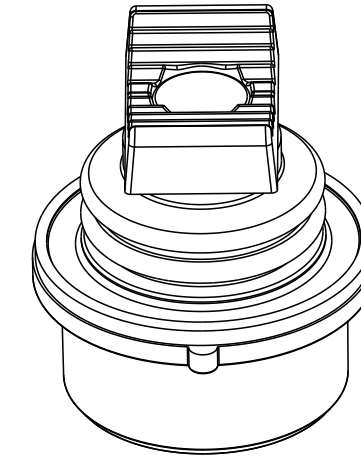
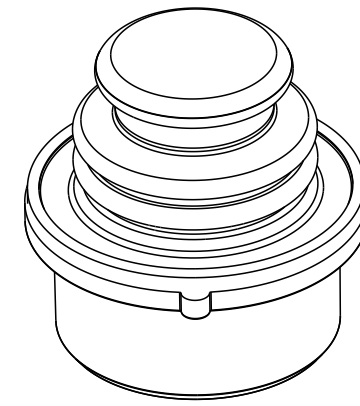

**BUTTON STYLE 5  
(EXTERNAL BAT  
HANDLE BOOT)**

**BUTTON STYLE 6  
(EXTERNAL SMOOTH BOOT)**

**BUTTON STYLE 7  
(LONG CONCAVE Y AXIS BUTTON)**

**BUTTON STYLE CONFIGURATION**

UNLESS OTHERWISE SPECIFIED DIMENSIONS ARE IN INCHES. TOLERANCES ARE AS LISTED. MUST BE FREE FROM BURRS AND SHARP EDGES	TOLERANCES	THIS DOCUMENT IS THE CONFIDENTIAL PROPERTY OF OTTO ENGINEERING, INC.. IT IS NOT TO BE USED IN ANY WAY DETRIMENTAL TO THE INTERESTS OF OTTO ENGINEERING, INC.	DRWN. JLW	SIZE	FSCM NO	DRAWING NO.	REV.
	.XX ±.03 .XXX ±.010 ANGLES ±2° DO NOT SCALE DRAWING		CHKD. DCF	C	21649	HTL2-_____	G
			APPD. AH	THIRD ANGLE PROJECTION	Scale 1:1	Sheet 4 OF 4	



Компания «ЭлектроПласт» предлагает заключение долгосрочных отношений при поставках импортных электронных компонентов на взаимовыгодных условиях!

Наши преимущества:

- Оперативные поставки широкого спектра электронных компонентов отечественного и импортного производства напрямую от производителей и с крупнейших мировых складов;
- Поставка более 17-ти миллионов наименований электронных компонентов;
- Поставка сложных, дефицитных, либо снятых с производства позиций;
- Оперативные сроки поставки под заказ (от 5 рабочих дней);
- Экспресс доставка в любую точку России;
- Техническая поддержка проекта, помощь в подборе аналогов, поставка прототипов;
- Система менеджмента качества сертифицирована по Международному стандарту ISO 9001;
- Лицензия ФСБ на осуществление работ с использованием сведений, составляющих государственную тайну;
- Поставка специализированных компонентов (Xilinx, Altera, Analog Devices, Intersil, Interpoint, Microsemi, Aeroflex, Peregrine, Syfer, Eurofarad, Texas Instrument, Miteq, Cobham, E2V, MA-COM, Hittite, Mini-Circuits, General Dynamics и др.);

Помимо этого, одним из направлений компании «ЭлектроПласт» является направление «Источники питания». Мы предлагаем Вам помощь Конструкторского отдела:

- Подбор оптимального решения, техническое обоснование при выборе компонента;
- Подбор аналогов;
- Консультации по применению компонента;
- Поставка образцов и прототипов;
- Техническая поддержка проекта;
- Защита от снятия компонента с производства.



#### Как с нами связаться

**Телефон:** 8 (812) 309 58 32 (многоканальный)

**Факс:** 8 (812) 320-02-42

**Электронная почта:** [org@eplast1.ru](mailto:org@eplast1.ru)

**Адрес:** 198099, г. Санкт-Петербург, ул. Калинина, дом 2, корпус 4, литера А.