



FEATURES

- 850W output power
- Climate Savers Computing InitiativesSM and 80 PLUS^R Gold efficiency
- 12V main output
- 3.3V or 5V standby output of 20W
- 1U sized; dimensions 3.20"x11.00"x1.57"
- 15.4 Watts per cubic inch density
- N+1 redundancy capable, including hot plugging (up to 4 in parallel)
- Active current sharing on 12V main output; ORing FET
- Overvoltage, overcurrent, overtemperature protection
- Internal cooling fan (variable speed)
- PMbus / I²C interface
- RoHS compliant

PRODUCT OVERVIEW

The D1U3CS-W-850-12-HxxC series are 80 PLUS Gold efficiency 850 watt, power factor corrected front end supplies with a 12V main output and a 5V or 3.3V (20W) standby. They have active current sharing and up to 4 supplies may be operated in parallel. The supplies may be hot plugged, they recover from overtemperature faults, and have logic and PMBus status signals. Their low profile 1U package and >15W/cubic inch power density make them ideal for delivering reliable, efficient power to servers, workstations, storage systems and other 12V distributed power systems.

ORDERING GUIDE

Part Number	Power Output	Main Output	Standby Output	Airflow
D1U3CS-W-850-12-HC4C	850W	12V	3.3V	Back to front
* D1U3CS-W-850-12-HA4C	850W	12V	5V	Back to front
* D1U3CS-W-850-12-HC3C	850W	12V	3.3V	Front to back
* D1U3CS-W-850-12-HA3C	850W	12V	5V	Front to back

INPUT CHARACTERISTICS

Parameter	Conditions	Min.	Nom.	Max.	Units
Voltage Operating Range		90	115/230	264	Vac
Frequency		47	50/60	63	Hz
Turn-on Voltage	Ramp up			90	Vac
Turn-off Voltage	Ramp down		73		
Maximum Current	850W, 100Vac			10	Arms
Inrush Current	Cold start between 0 to 200msec			25	Apk
Power Factor	At 230Vac, full load		0.98		
Efficiency (230Vac) excluding fan load	20% load	88	89		%
	50% load	92	93.5		
	100% load	88	93		

OUTPUT VOLTAGE CHARACTERISTICS

Output Voltage	Parameter	Conditions	Min.	Typ.	Max.	Units
12V	Voltage Set Point Accuracy	50% load	11.97	12.0	12.02	Vdc
	Line and Load Regulation		11.4		12.6	
	Ripple Voltage & Noise ¹	20MHz Bandwidth			120	mV p-p
	Output Current		0		69.2	A
	Load Capacitance				10000	µF
3.3VSB	Voltage Set Point Accuracy	50% load	3.28	3.3	3.32	Vdc
	Line and Load Regulation		3.13		3.46	
	Ripple Voltage & Noise ¹	20MHz Bandwidth			50	mV p-p
	Output Current		0		6	A
	Load Capacitance				350	µF
5VSB	Voltage Set Point Accuracy			5.0		Vdc
	Line and Load Regulation		4.85		5.15	
	Ripple Voltage & Noise ¹	20MHz Bandwidth			50	mV p-p
	Output Current		0		4	A
	Load Capacitance				TBD	µF

¹ Ripple and noise are measured with 0.1 µF of ceramic capacitance and 10 µF of tantalum capacitance on each of the power supply outputs. A short coaxial cable with 50ohm scope termination is used.

* Contact Murata Sales for availability.



OUTPUT CHARACTERISTICS					
Parameter	Conditions	Min.	Typ.	Max.	Units
Output Rise Monotonicity	No voltage excursion				
Start-up Time	AC ramp up		1.5	3	s
Transient Response	12V, 50-100% load step, 0.1A/μs di/dt		150		mV
	5VSB, 50-100% load step, 0.1A/μs di/dt		TBD		
	3.3VSB, 50-100% load step, 0.1A/μs di/dt		165		
Current sharing accuracy (up to 4 in parallel)	At 100% load		2.5	±7	%
Hot Swap Transients	All outputs within regulation				
Hold-up Time	100V, 50Hz	20	25		ms

ENVIRONMENTAL CHARACTERISTICS					
Parameter	Conditions	Min.	Typ.	Max.	Units
Storage Temperature Range		-40		85	°C
Operating Temperature Range		-10		55	
Operating Humidity	Noncondensing	5		90	%
Storage Humidity		5		95	
Altitude (without derating at 45°C)		3000			m
Shock	30G non operating				
Sinusoidal Vibration	0.5G, 5 – 500 Hz				
MTBF	Calculated per Telcordia SR322M1C1 @40°C	500K			hrs
Acoustic	ISO 7779-1999			55	dB LpAm
Safety Approvals	CSA/UL 60950-1-07-2nd Ed. IEC 60950-1:2005 (2nd Edition) EN 60950-1:2006 +A11 CE Marking per LVD DIRECTIVE 2006/95/EC				
Input Fuse	Power Supply has internal 15A/250V fast blow fuse on the AC line input				
Material Flammability	UL 94V-0				
Switching Frequency	90KHz for Boost PFC Converter 130KHz for Main Output Converter				
Weight	3.15lbs (1.43kg)				

PROTECTION CHARACTERISTICS						
Output Voltage	Parameter	Conditions	Min.	Typ.	Max.	Units
12V	Overtemperature (intake)	Autorestart		65		°C
	Overvoltage	Latching	13.2		14.4	V
	Overcurrent	Latching		81		A
3.3VSB	Overvoltage	Latching	3.6		4.0	V
	Overcurrent	Autorecovery		7.4		A
5VSB	Overvoltage	Latching	5.6		6.0	V
	Overcurrent	Autorecovery	4.4		6.0	A

ISOLATION CHARACTERISTICS					
Parameter	Conditions	Min.	Typ.	Max.	Units
Insulation Safety Rating / Test Voltage	Input to Output - Reinforced	3000			Vrms
	Input to Chassis - Basic	1500			Vrms
Isolation	Output to Chassis	500			Vrms
Material Flammability	UL 94V-0				

EMISSIONS AND IMMUNITY		
Characteristic	Description	Criteria
Harmonics	IEC/EN 61000-3-2	
Voltage Fluctuation and Flicker	IEC/EN 61000-3-3	
Emission Conducted	FCC 47 CFR Part 15/CISPR 22/EN55022	Class A, 6dB margin
ESD	IEC/EN 61000-4-2	Level 3 criteria B
Electromagnetic Field	IEC/EN 61000-4-3	Level 3 criteria B
Electrical Fast Transients/Burst	IEC/EN 61000-4-4	Level 3 criteria B
Surge	IEC/EN 61000-4-5	Level 4 criteria B
RF Conducted	IEC/EN 61000-4-6	Level 3 criteria A
Magnetic Field	IEC/EN 61000-4-8	3 A/m criteria B
Voltage dips, interruptions	IEC/EN 61000-4-11	230Vin, 100% load, Phase 0°, Dip 100% Duration 10ms (A) 230Vin, 50% load, Phase 0°, Dip 100% Duration 20ms (VSB:A, V1:A) 230Vin, 100% load, Phase 0°, Dip 100% Duration > 20ms (VSB, V1:B)

All specifications are at 25°C ambient, unless otherwise stated.

OUTPUT CONNECTOR AND SIGNAL SPECIFICATION

DC and Signal Connector: FCI 51721-10002406AA

D1	D2	D3	D4	D5	D6	PB1	PB2	PB3	PB4	PB5	PB6
C1	C2	C3	C4	C5	C6						
B1	B2	B3	B4	B5	B6						
A1	A2	A3	A4	A5	A6						

Pin Assignment	Signal Name	Description	Amps per pin
PB1, PB2, PB3	+12V_GND	Main output voltage, return	30
PB4, PB5, PB6	+12V_OUT	Main output voltage	30
A1	PS_ON	Power supply "ON"	N/A
A2	+12VRS_RETURN	Main output remote sense, return	N/A
A3	TEMP_OK	Temperature "OK" signal output	N/A
A4	PS_SEATED	Power supply is plugged into the system	N/A
A5, B5, C5, D5	+VSB	Standby output voltage	2.0
A6, B6, C6, D6	+VSB_GND	Standby output voltage, return	2.0
B1	AC_OK	Input AC voltage "OK" signal output	N/A
B2	+12VRS	Main output remote sense	N/A
B3	+12V_ISHARE	Main output active load sharing bus	N/A
B4	PS_INHIBIT/PS_KILL	Floating pin will turn off the power supply (shorter pin, last-make and first-break contact for hot plugging) . This signal overrides PS_ON in disabling the main output.	N/A
C1	SDA	Data line	N/A
C2	SCL	Clock line	N/A
C3	PWR_GD	Power good	N/A
C4	FAN_FAIL	Fan failure	N/A
D1	A0		N/A
D2	A1		N/A
D3	S_INT		N/A
D4	NO CONNECTION		N/A

D1U MATING CONNECTORS

D1U Mating Connector	Press Fit	
	Straight	Right Angle
Murata Power Solutions	TBD	
FCI	TBD	51761-10002406AA

MECHANICAL DIMENSIONS

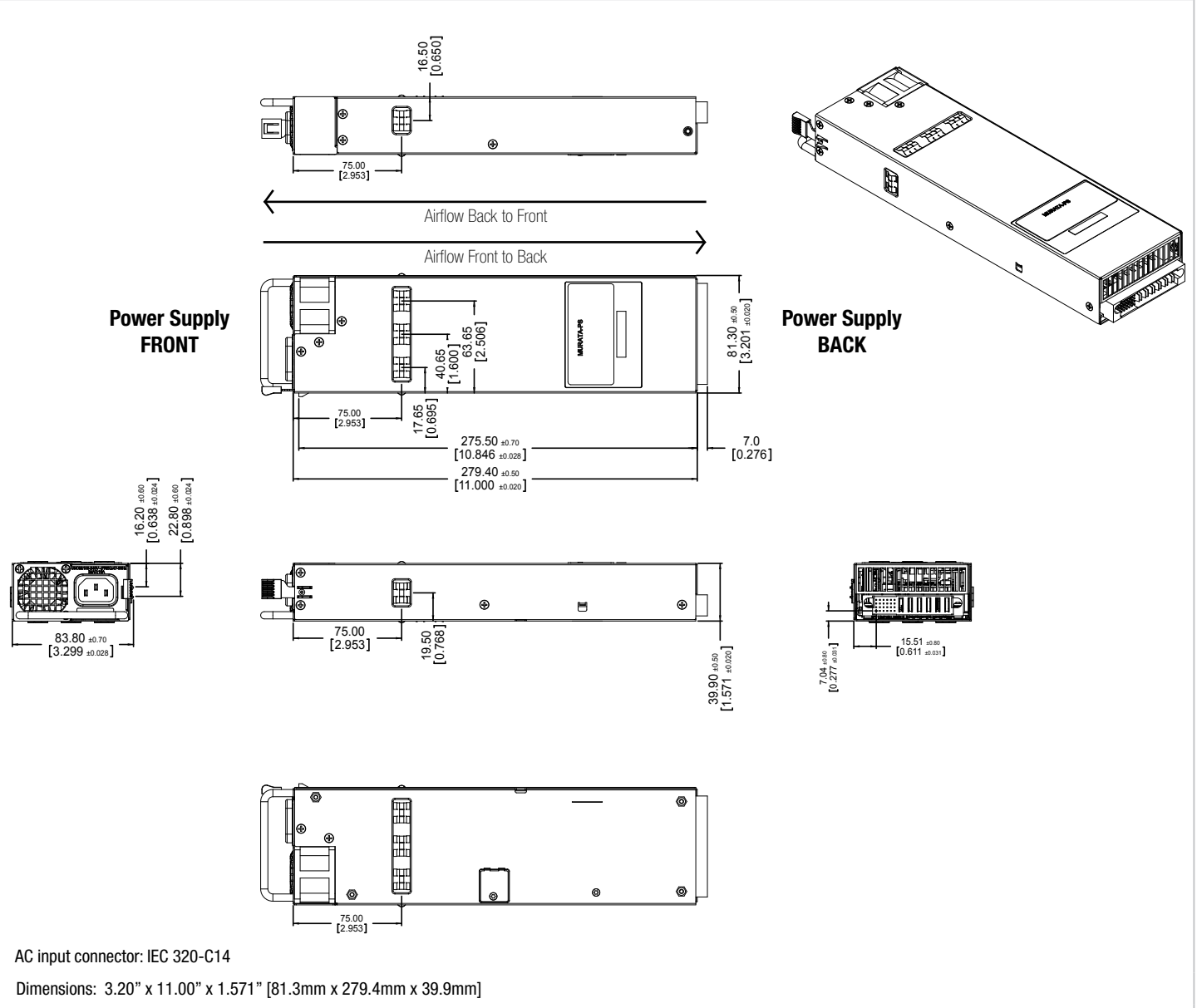

OPTIONAL ACCESSORIES

Description	Part Number
12V D1U3CS Output Connector Card	D1U3CS-12-CONC

APPLICATION NOTES

Document Number	Description
TBD	Output Connector Card for D1U3CS
TBD	D1U3CS Communication Protocol

Murata Power Solutions, Inc.
 11 Cabot Boulevard, Mansfield, MA 02048-1151 U.S.A.
 ISO 9001 and 14001 REGISTERED



This product is subject to the following operating requirements and the Life and Safety Critical Application Sales Policy: Refer to: <http://www.murata-ps.com/requirements/>

Murata Power Solutions, Inc. makes no representation that the use of its products in the circuits described herein, or the use of other technical information contained herein, will not infringe upon existing or future patent rights. The descriptions contained herein do not imply the granting of licenses to make, use, or sell equipment constructed in accordance therewith. Specifications are subject to change without notice. © 2012 Murata Power Solutions, Inc.



Компания «ЭлектроПласт» предлагает заключение долгосрочных отношений при поставках импортных электронных компонентов на взаимовыгодных условиях!

Наши преимущества:

- Оперативные поставки широкого спектра электронных компонентов отечественного и импортного производства напрямую от производителей и с крупнейших мировых складов;
- Поставка более 17-ти миллионов наименований электронных компонентов;
- Поставка сложных, дефицитных, либо снятых с производства позиций;
- Оперативные сроки поставки под заказ (от 5 рабочих дней);
- Экспресс доставка в любую точку России;
- Техническая поддержка проекта, помощь в подборе аналогов, поставка прототипов;
- Система менеджмента качества сертифицирована по Международному стандарту ISO 9001;
- Лицензия ФСБ на осуществление работ с использованием сведений, составляющих государственную тайну;
- Поставка специализированных компонентов (Xilinx, Altera, Analog Devices, Intersil, Interpoint, Microsemi, Aeroflex, Peregrine, Syfer, Eurofarad, Texas Instrument, Miteq, Cobham, E2V, MA-COM, Hittite, Mini-Circuits, General Dynamics и др.);

Помимо этого, одним из направлений компании «ЭлектроПласт» является направление «Источники питания». Мы предлагаем Вам помощь Конструкторского отдела:

- Подбор оптимального решения, техническое обоснование при выборе компонента;
- Подбор аналогов;
- Консультации по применению компонента;
- Поставка образцов и прототипов;
- Техническая поддержка проекта;
- Защита от снятия компонента с производства.



Как с нами связаться

Телефон: 8 (812) 309 58 32 (многоканальный)

Факс: 8 (812) 320-02-42

Электронная почта: org@eplast1.ru

Адрес: 198099, г. Санкт-Петербург, ул. Калинина, дом 2, корпус 4, литера А.