

IS-Dev Kit-5 and IS-Dev Kit-6 Users Manual

Revision A

IS-Dev Kit-5 and IS-Dev Kit-6 Version 1.2



NKK SWITCHES
7850 E. Gelding Drive
Scottsdale, AZ 85260

Toll Free 1-877-2BUYNKK (877-228-9655)
Phone 480-991-0942
Fax 480-998-1435
e-mail <engineering@nkkswitches.com>

All Rights Reserved Worldwide

NKK Switches makes no warranty for the use of these products and assumes no responsibility for any errors, which may appear in this document, nor does it make a commitment to update the information contained herein. Smart Switch is trademark of NKK Switches.

TABLE OF CONTENTS

Table of Contents	2
1. General Features	3
2. Dev Kits Where Used	3
3. Compatible Logic Boards.....	3
4. Operational Overview.....	4
5. Operational Details	7
6. Communication Protocol.....	9
7. Hardware	18
8. Key Terms & Definitions.....	23
9. Firmware problems	24

1. General Features

The IS-Dev Kit-5 and IS-Dev Kit-6 come in three versions each demonstrating different SmartSwitches, Compacts, and Displays as shown in section 2 below. The controller for these Dev Kits is the IS-C0203.

Below are current features:

- IS-C0203 controller controls two LCD 64x32 switches/displays or two LCD 36x24 switches/displays
- Serial communication via RS232 (57.6K, 1 start bit, 8 bit , 1 stop bit)
- Optional audio feedback while switch is pressed.
- Program responses to switch-actions events and timer-expire events.
- User programmable for images, attributes and set-ups.
- Set the type of activity reports from the controller to host.
- LED Brightness settings.
- Flash memory for 255 pictures and attributes.
- Reports switch activity and timer expiration via serial port.
- Stand alone operation or real time control by host.
- The firmware can be customized based on customer requirements.

2. Dev Kits Where Used

The following is a list of SmartSwitch Dev Kits where the IS-C0203 controller is used.

- | | |
|------------------|-----------------------|
| A. IS-Dev Kit-6 | LCD 64x32 RGB |
| B. IS-Dev Kit-6D | LCD 64x32 RGB Display |
| C. IS-Dev Kit-6C | LCD 64x32 Compact |
| D. IS-Dev Kit-5 | LCD 36x24 RGB, |
| E. IS-Dev Kit-5D | LCD 36x24 RGB Display |
| F. IS-Dev Kit-5C | LCD 36x24 RGB Compact |

3. Compatible Logic Boards

The following is a list of compatible Logic Boards and switches.

- | | |
|---------------|--------------------------------|
| G. IS-L02A1-C | LCD 64x32 RGB |
| H. IS-L02F1-C | LCD 64x32 RGB Display |
| I. IS-L02H2-C | LCD 64x32 Compact |
| J. IS-L0204-C | LCD 36x24 RGB |
| K. IS-L0251-C | LCD 36x24 RGB Display |
| L. IS-L0271-C | LCD 36x24 RGB Compact |
| M. IS-L0205-C | LCD 36x24 Bicolor/single color |

4. Operational Overview

Power-up Sequence:

Upon power up, the controller checks the position of the Mode Select Switch. The switch position has to match the logic board/switches connected. The “High res” position will work only for LCD 64x32 switches/displays while the “Standard res” position will work only for LCD 36x24 switches/displays.

Note: Setting the switch to a different setting than the Logic Board type may damage the assembly.

LED Brightness Adjustment Mode:

The controller will then allow the backlight brightness to be adjusted. Press the left hand switch to make both LED modules dimmer. Press the right hand switch to make both LED modules brighter.

Main Operational Mode:

After a few seconds of user inactivity the controller will move into the main operations mode where the switch on the left displays the image at the user’s first preset address. The right hand switch will display the image at the user’s second preset address. The controller will then respond to a switch actuation or a timer expiration as set by the user preset attributes.

Addresses:

A one byte value ranging from 01H to FFH representing the 255 memory.

Attribute Block for 64x32 Resolution Switches

A block of 8 bytes.

Byte	Description
1	Address for LCD Module #1 when switch is pressed.
2	Address for LCD Module #2 when switch is pressed
3	Address for LCD Module #1 when the timer is expired.
4	Address for LCD Module #2 when the timer is expired.
5	Value for TIMER 1
6	Value for TIMER 2
7	LED CODE for on cycle
8	LED CODE for off cycle

LED Backlighting for 64x32 Resolution Switches:

The LED code has two bytes, one byte for “on cycle” and one byte for “off cycle”. The format for both bytes is the same. Following is the byte format:

B7	B6	B5	B4	B3	B2	B1	B0
R	R	G	G	B	B	1	1

For each of red, green and blue color:

- 00=off**
- 01= ¼ brightness**
- 10 = ½ brightness**
- 11= full brightness**

Image Block for 64x32 Resolution Switches:

Bit map format for the Legend block

Byte 8	Byte 7	...	Byte2	Byte 1
D7D6D5D4D3D2D1D0	D7D6...D1D0	...	D7D6...D1D0	D7D6D5D4D3D2D1D0
Byte 16		...		Byte 9
D7D6D5D4D3D2D1D0		...		D7D6D5D4D3D2D1D0
.
.
.
.
Byte 256		...		Byte 249
D7D6D5D4D3D2D1D0	D7D6...D1D0	...	D7D6...D1D0	D7D6D5D4D3D2D1D0

Please note this bit map is different than the switch bitmap.

Attribute Block for 36x24 Resolution Switches

A block of 6 bytes.

Byte	Description
1	Address for LCD Module #1 when switch is pressed.
2	Address for LCD Module #2 when switch is pressed
3	Address for LCD Module #1 when the timer is expired.
4	Address for LCD Module #2 when the timer is expired.
5	Value for TIMER 1
6	Value for TIMER 2

Image Block for 36x24 Resolution Switches:

A block of 125 bytes. It contains picture data and LED codes.

Byte	Description
1-5	First line of picture
6-10	Second line of picture
•	
•	
•	
116-120	24th line of picture
121	LED code
122-125	reserved

LED Backlighting for 36x24 Resolution Switches:

The LED code is one byte with the following format:

B7=0 ==> Reserved

B7=1 ==> Reserved

B6=0 ==> Blue backlighting off during "OFF CYCLE"

B6=1 ==> Blue backlighting on during "OFF CYCLE"

B5=0 ==> Green backlighting off during "OFF CYCLE"

B5=1 ==> Green backlighting on during "OFF CYCLE"

B4=0 ==> Red backlighting off during "OFF CYCLE"

B4=1 ==> Red backlighting on during "OFF CYCLE"

B3=0 ==> LCD normal

B3=1 ==> LCD inverse

B2=0 ==> Blue backlighting off during "ON CYCLE"

B2=1 ==> Blue backlighting on during "ON CYCLE"

B1=0 ==> Green backlighting off during "ON CYCLE"

B1=1 ==> Green backlighting on during "ON CYCLE"

B0=0 ==> RED backlighting off during "ON CYCLE"

B0=1 ==> RED backlighting on during "ON CYCLE"

5. Operational Details

Power-Up Sequence (Steps 1,2,3)

Upon power-up or reset, controller performs the following steps:

Step 1: Check the status of Mode Select Switch for mode of operation. Initialize according to selected mode.

Step 2: Check if the flash RAM has been programmed. Compare the check string to flash RAM string.

A. If the strings are not the same, the flash RAM is virgin and its data is not acceptable. Step 3 will be executed. (first time)

B. If the strings are the same, the data from RAM is acceptable. Step 3 is omitted and Step 4 is executed.

Step 3: Write all the default initialize values to the flash memory as follows:

A. Put “BLANK FONT MEMORY” as the picture for location one.

B. Put “BLANK FONT MEMORY” as the picture for location two.

C. Put ONcycle LED’s ON for location #1 and #2.

D. Put OFFcycle LED’s off for location #1 and #2.

E. Put “00H 00H 00H 00H 00H 00H” as attribute for location #1 and #2.

F. Put 00H for software version

G. Write the default setup values such OFFcycle, ON/OFF ratio...

H. Write the virgin check string.

Step 4: LED brightness adjustment as follows:

A. Display “DOWN LED” and “UP LED” on the two switches and allow for adjustments of the brightness. There are 8 brightness levels (0 to 7). When the internal timer is expired, the controller proceeds to Step 5. Every time a switch is pressed, the timer gets reset. If a switch is held depressed the timer does not run. Switch activity are not reported to host.

B. When the timer expires transmit 83H

C. Initialize and load the data from location 1 and 2 of EEPROM to internal RAM for switch 1 and 2 respectfully.

Main Operational Mode

Step 5:

A. If the switch one is pressed: Transmit 81H to host and execute the attribute.
(For details see **Attribute Execution**)

B. If the switch two is pressed: Transmit 82H to host and execute the attribute.
(For details see **Attribute Execution**)

C. If the timer for switch 1 is expired: Transmit 83H to host and execute the timer attribute.
(For details see **Attribute Execution**)

D. If the timer for switch 2 is expired: Transmit 84H to host and execute the timer attribute.
(For details see **Attribute Execution**)

E. If the switch one is released: Transmit B1H to host.

- F. If the switch two is released: Transmit B2H to host.
- G. Checks the host communication buffer for data. If there is data, process them.
(For details see **Communication Protocol**)
- H. Go to step 5 section A

Attributes Execution

When a switch is pressed the attributes are executed as follows:

- A. The timer for the switch is reset and does not run until the switch is released.
- B. If byte 1 of the switch attributes is not equal to zero then the Legend block and attribute block from the EEPROM is transferred to internal RAM for switch 1. The Legend, backlighting and timer values are put in effect for switch 1.
- C. If byte 1 of the switch attributes is equal zero then there will be no change to Legend/attribute of the switch 1.
- D. If byte 2 of the switch attributes is not equal to zero then the Legend block and attribute block from the EEPROM is transferred to internal RAM for switch 2. The Legend, backlighting and timer values are put in effect for switch 2.
- E. If byte 2 of the switch attributes is equal zero then there will be no change to Legend/attribute of the switch 2.

When one of the timers is expired the attributes are executed as follows:

- A. The timer that expired gets reset.
- B. Both timers will pause until attributes are executed.
- C. If byte 3 of switch attributes is not equal zero then the Legend block and attribute block from the EEPROM is transferred to internal RAM for switch 1. The Legend, backlighting and timer values are put in effect for switch 1.
- D. If byte 3 of switch attributes is equal zero then there will be no change to Legend/attributes of the switch 1.
- E. If byte 4 of the switch attributes is not equal to zero then the Legend block and attribute block from the EEPROM is transferred to internal RAM for switch 2. The Legend, backlighting and timer values are put in effect for switch 2.
- F. If byte 4 of the switch attributes is equal zero then there will be no change to Legend/attribute of the switch 2.

Timers Operation

- Switch one and switch two timers run independently.
- Timer will be disabled if the timer 1 value is zero.
- The timer value in second = (TIMER 1)x(TIMER 2)x(0.0369)
- TIMER 2 = 0 counts as 256.

6. Communication Protocol

The controller communicates with the host by serial communication via RS232 (57.6K, 1 start bit, 8 bit, 1 stop bit). The controller receives the data via an interrupt routine that places the data on the circular receive buffer. When the controller detects data in the circular receive buffer, at Step 5G, it reads one byte and executes the following:

- A. If the byte is a command, the controller transmits a 61H and executes the subroutine for the command and upon completion of command the controller transmits 79H. All of the commands are explained in detail in this section.
- B. If the byte is not a command, it is ignored.

When the controller executes a subroutine and expects additional information:

- A. A timer is set. If the expected data byte is not received in 50ms, the controller transmits 6EH and terminates the routine.
- B. If the byte value is not acceptable (invalid range, option, etc.), the controller transmits 6EH and terminates the routine.

Commands are one byte in the range of 20H to 2FH and 01H and are transmitted in hex format. The proper format for all command options and data is specified for each command.

Commands to the controller

Command to reboot the controller

The command reboots the controller to power-up state.

command format: **24H**
transmit format: (xxH)

Command to check communication

The command is used to check if the controller is on-line.

command format: **01H**
transmit format: (xxH)

The controller transmits back 61H to the host.

Command to download a Legend block

This command downloads a Legend block from the host to the EEPROM location.

command format: **28H** [Address] [Legend Block]
transmit format: (xxH) (xxAH) (xxAH)

[Address] is one byte with value of 01H to FFH sent as ASCII HEX format.

[Legend Block] is 125 bytes in LCD 36x24 mode and is 256 bytes in LCD 64x32 mode transmitted in ASCII HEX format.

The controller disables the timers and switch execution upon receiving this command. However, the switches are still scanned and reported. They are enabled upon reboot/power up or by command from host.

Command to upload a Legend block

This command uploads a Legend block from the EEPROM location to the host.

command format: **29H** [Address]
transmit format: (xxH) (xxAH)

[Address] is one byte with value of 01H to FFH sent as ASCII HEX format.

The controller transmits back the image (125 bytes in LCD 36x24 mode and is 256 bytes in LCD 64x32 mode) in HEX format.

The controller disables the timers and switch execution upon receiving this command. However, the switches are still scanned and reported. They are enabled upon reboot/power up or by command from host.

Command to download attribute block

This command downloads an attribute block from the host to the EEPROM location.

command format: **2AH** [Address] [Attribute Block]
transmit format: (xxH) (xxAH) (xxAH)

[Address] is one byte with value of 01H to FFH sent as ASCII HEX format.

[Attribute Block] is six bytes in LCD 36x24 mode and is eight bytes in LCD 64x32 mode transmitted in ASCII HEX format.

The controller disables the timers and switch execution upon receiving this command. However, the switches are still scanned and reported. They are enabled upon reboot/power up or by command from host.

Command to upload an attribute block

This command uploads an attribute block from the EEPROM location to the host.

command format: **2BH** [Address]
transmit format: (xxH) (xxAH)

[Address] is one byte with value of 01H to FFH sent as ASCII HEX format.

[Attribute Block] is six bytes in LCD 36x24 mode and is eight bytes in LCD 64x32 mode transmitted in ASCII HEX format.

The controller transmits back the [Attribute block] in hex format.

The controller disables the timers and switch execution upon receiving this command. However, the switches are still scanned and reported. They are enabled upon reboot/power up or by command from host.

Command to set LED codes

This command sets the LED backlights according to the command's LED codes.

command format: **2CH** 00H [LED for Switch 1] [LED for Switch 2]
transmit format: (xxH) (xxAH) (xxAH) (xxAH)

[LED for switch 1] is one byte for LCD 36x24 and two bytes for LCD 64x32 (first byte for on-cycle and second byte for off cycle).

[LED for switch 2] is one byte for LCD 36x24 and two bytes for LCD 64x32 (first byte for on-cycle and second byte for off cycle).

Example: The following hex string makes switch 1 display green for "ON/OFF CYCLE" and switch 2 display white for 'ON CYCLE' and red for "OFF CYCLE"

For LCD 36x24 mode
2C 00 3232 3137

For LCD 64x32 mode
2C 00 3333 3333 4646 4233

Command to transfer from EEPROM to internal RAM by Addresses

This command transfers the data from EEPROM to internal RAM according to the addresses. If either of the address values is zero no transfer takes place for that address.

command format: **2DH** 00H [Address for Switch 1] [Address for Switch 2]
transmit format: (xxH) (xxH) (xxAH) (xxAH)

[Address for Switch 1] is one byte with value of 00H to FFH.

[Address for Switch 2] is one byte with value of 00H to FFH.

Example: The following hex string makes switch 1 display the data from location 5 and makes switch 2 display the data from location 6. **2D 00 3035 3036**

Command to transfer from EEPROM to internal RAM for one Address

This command updates the specified switch with the data from EEPROM using the address.

command format: **2EH** [LCD Module #] [Address]
transmit format: (xxH) (31H or 32H) (xxAH)

[LCD Module #] is the switch number (31H for switch 1, 32H for switch 2)

[Address] is one byte with value of 01H to FFH.

Command to set one LCD/LED Code

This command updates the LED's of specified switch with the LED code.

command format: **2FH** [LCD Module #] [LED code]
transmit format: (xxH) (31H or 32H) (xxAH)

[LCD Module #] is the switch number (31H for switch 1, 32H for switch 2)

[LED code] is one byte for LCD 36x24 and two bytes for LCD 64x32 (first byte for on-cycle and second byte for off cycle). B0 and B1 must be 1 for LCD 64x32.

Command to query controller for mode, controller, and firmware version

This command queries the controller for the mode as set by the Mode Select Switch, the controller name, and the firmware version installed.

command format: **26H** 52H 58H
transmit format: (xxH) (xxH) (xxH)

Example: The command is sent. The controller responds with the following:

61	31	43 30 32 30 33	3131	79
61H	[mode]	[Controller name]	[version]	79H

[mode] is one byte. 31H indicates LCD 36x24 module mode or 32H indicates LCD 64x32 mode.

[Controller name] is five bytes. 43H 30H 32H 30H 33H (C0203)

[version] is one byte. 12H (version 1.1)

Command to upload the active Addresses

This command transmits 61H followed by the active addresses for switch 1 and 2 in hex format.

command format: **26H** 00H
transmit format: (xxH) (xxH)

Command to set the data version

This command sets the version of the data in the FLASH memory. Default value (00H).

command format: **26H** 42H [Data Version]
transmit format: (xxH) (xxH) (xxAH)

Command to upload the data version

This command uploads the version of the data in the FLASH memory to the host in one byte HEX format.

command format: **26H** 41H
transmit format: (xxH) (xxH)

Command to uploads the FIRMWARE version

This command uploads the FIRMWARE version to the host in one byte HEX format.

command format: **26H** 15H
transmit format: (xxH) (xxH)

Command to set LED Brightness

This command sets the LED brightness for the duration of the session.

command format: **26H** 51H 53H [LED Brightness]
transmit format: (xxH) (xxH) (xxH) (xxAH)

[LED BRIGHTNESS] is one byte from 00H (dimpest) to 07H (brightest). The upper 5 bits of the byte are ignored.

This command is for duration of the session. It can become permanent by “**Command to write the setup values to the EPROM**”.

Command to set LED press value

This command sets the LED code for when the switch is pressed. It applies to LCD 36x24 switches only.

command format: **26H** 51H 55H [LED code]
transmit format: (xxH) (xxH) (xxH) (xxAH)

[LED code] is one byte for LCD 36x24. B0 of FLAG A must be set. LCD 36x24 only

This command is for duration of the session. It can become permanent by “**Command to write the setup values to the EPROM**”.

Command to set LED off cycle duration

This command sets the duration of the off cycle.

command format: **26H** 51H 57H [LED OFF cycle]
transmit format: (xxH) (xxH) (xxH) (xxAH)

[LED OFF cycle] is one byte.

This command is for duration of the session. It can become permanent by “**Command to write the setup values to the EPROM**”.

Command to set LED on cycle duration

This command sets the duration of the on cycle.

command format: **26H** 51H 59H [LED ON/OFF cycle]
 transmit format: (xxH) (xxH) (xxH) (xxAH)

[LED ON/OFF cycle] is one byte.

Duration of ON cycle = ([LED ON/OFF]-1) *(duration of OFF cycle)

This command is for duration of the session. It can become permanent by “**Command to write the setup values to the EPROM**”.

Command to set FLAG A

This command sets Flag A.

command format: **26H** 51H 5BH [FLAG A]
 transmit format: (xxH) (xxH) (xxH) (xxAH)

[FLAG A] is one byte. See table below.

This command is for duration of the session. It can become permanent by “**Command to write the setup values to the EPROM**”.

Flag Byte A Default Value=7EH

Bit	Enable Value	Flag	Controller action when flag is set
B0	1	LED press flag	Switch backlight change according to LED press value while the switch is pressed. For LCD 36x24 only.
B1	1	61H flag	61H is transmitted in response to command.
B2	1	79H flag	79H is transmitted upon completion of command.
B3	1	Switch release report flag	Switch releases are reported
B4	1	6EH flag	6EH is transmitted if there is any error during communication to host.
B5	1	Switch press report flag	Switch presses are reported
B6	1	Timer 1 and 2 expire report flag	Timer 1 and 2 expiration is reported
B7	1	Address change report flag	Newest address is reported for each switch

Command to download FLAG B

This command sets Flag B.

command format: **26H** 51H 5CH [FLAG B]
 transmit format: (xxH) (xxH) (xxH) (xxAH)

[FLAG B] is one byte. See table below.

This command is for duration of the session. It can become permanent by “**Command to write the setup values to the EPROM**”.

Flag Byte B Default Value=01H

Bit	Enable Value	Flag	Controller action when flag is set
B0	1	BEEPER	Beep for switch press
B1	0	Reserved	
B2	0	Reserved	
B3	0	Reserved	
B4	0	Reserved	
B5	0	Reserved	
B6	0	Reserved	
B7	0	Reserved	

Command to set timers for LED up/ LED down

This command sets the timers that determine the time “DOWN LED” and “UP LED” are displayed upon power up. Every time the switches are pressed the timers get reset.

command format: **26H** 51H 5DH [Timer1] [Timer2]
 transmit format: (xxH) (xxH) (xxH) (xxAH) (xxAH)

[Timer1] is one byte from 01H to FFH. 00H is not acceptable. Default (09H)

[Timer2] is one byte from 00H to FFH. 00H =256. Default (09H)

This command does not go to effect until it becomes permanent. It can become permanent by “**Command to write the setup values to the EPROM**”.

Command to download power up Addresses

This command sets the addresses for switch 1 and switch 2 upon power up or reset.

command format: **26H** 51H 5EH [Address for Switch 1] [Address for Switch 2]
 transmit format: (xxH) (xxH) (xxH) (xxAH) (xxAH)

[Address for Switch 1] is one byte from 01H to FFH. 00H is not acceptable. Default (01H)

[Address for Switch 2] is one byte from 01H to FFH. 00H is not acceptable. Default (02H)

This command does not go to effect until it becomes permanent. It can become permanent by “**Command to write the setup values to the EPROM**”.

Command to write the setup values to the EPROM

This command writes the setup values to the flash as per the following table. Once commanded the values become permanent.

- command format: **26H** 51H 4FH 34H 46H
transmit format: (xxH) (xxH) (xxH) (xxH) (xxH)
- LED press value
 - LED brightness level
 - LED off cycle duration
 - LED on/off cycle ratio
 - FLAG A
 - FLAG B
 - Timers for LED up/LED down
 - Power up addresses

Command to reset the setup values to the default values

This command writes the default values to the flash. Once commanded the values become permanent after power up or reboot. Sets Addresses 01H and 02H memories to “BLANK FONT MEMORY”.

- command format: **26H** 51H 4EH 34H 45H
transmit format: (xxH) (xxH) (xxH) (xxH) (xxH)

Command to fill display with specified byte

This command displays a specified byte over all of the display.

- command format: **27H** [LCD Module #] 00H [Byte]
transmit format: (xxH) (31H or 32H) (xxH) (xxAH)

[LCD Module #] is the switch number (31H for switch 1, 32H for switch 2)
[Byte] Specified byte.

Command to transfer the RAM to specified address

This command transfers the RAM to the specified address.

- command format: **27H** [LCD Module #] 02H [Address]
transmit format: (xxH) (31H or 32H) (xxH) (xxAH)

[LCD Module #] is the switch number (31H for switch 1, 32H for switch 2)
[Address] is one byte with value of 01H to FFH.

Command to download ASCII string (7x10 fonts)

This command downloads and displays an ASCII string.

command format: **27H** [LCD Module #] 70H [ASCII string]
transmit format: (xxH) (31H or 32H) (xxH) (xxAH)

[LCD Module #] is the switch number (31H for switch 1, 32H for switch 2)

[ASCII string] is 8 characters for LCD 36x24 and 24 characters for LCD 64x32. The controller will make 2 lines of 4 characters using the 7x10 fonts for LCD 36x24. The controller will make 3 lines of 8 characters using the 7x10 fonts for LCD 64x32.

LCD 36x24: 8 ASCII characters. LCD 64x32: 24 ASCII characters

Example: The following hex string makes switch 1 display A to X on LCD 64x32.

27 31 70 4142 4344 4546 4748 494A 4B4C 4D4E 4F50 5152 5354 5556 5758

Command to download ASCII string (5x7 fonts)

This command downloads and displays an ASCII string.

command format: **27H** [LCD Module #] 50H [ASCII string]
transmit format: (xxH) (31H or 32H) (xxH) (xxAH)

[LCD Module #] is the switch number (31H for switch 1, 32H for switch 2)

[ASCII string] is 18 characters. The controller will make 3 lines of 8 characters using the 5x7 fonts for LCD 36x24.

LCD 36x24: 18 ASCII characters. LCD 64x32: not available.

Example: The following hex string makes switch 1 display A to X on LCD 36x24.

27 31 50 4142 4344 4546 4748 494A 4B4C 4D4E 4F50 5152

7. Hardware

Controls Overview



The **Mode Select Switch** has two settings; “High res” is for the LCD 64x32 (64x32) switches/ displays and “Standard res” is for the LCD 36x24 RGB switches/ displays.

The **Connector** is for the installation of the Logic Boards onto the controller. One pin is keyed to reduce miss mates.

Note: Improper installation of the Logic Boards could damage either/both the Logic Board and controller.

The **Batt/PWR switch** has three positions: battery, off, line power.

Buzzer Volume adjusts the volume of the buzzer that activates when a button is pushed.

The **9V DC Power** jack mates with a 2.5mm cylinder power connector. Center positive.

The **RS232 Connector** links the controller to the host.

	1	2	3	4	5	6
RS232		GND	TX	RX	GND	

Controller Schematic

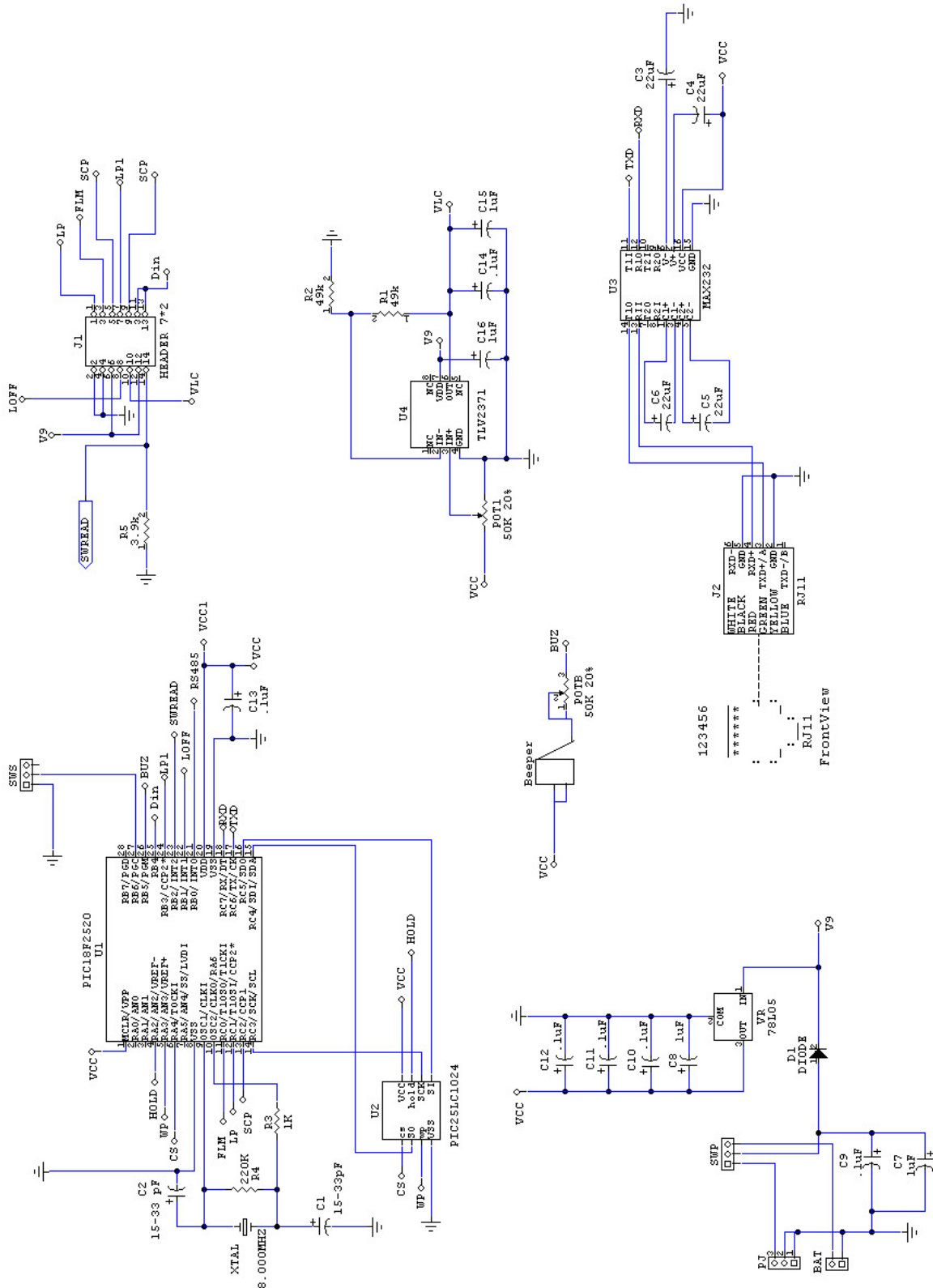

Logic Board Schematic for Two LCD 36x24 RGB SmartSwitch

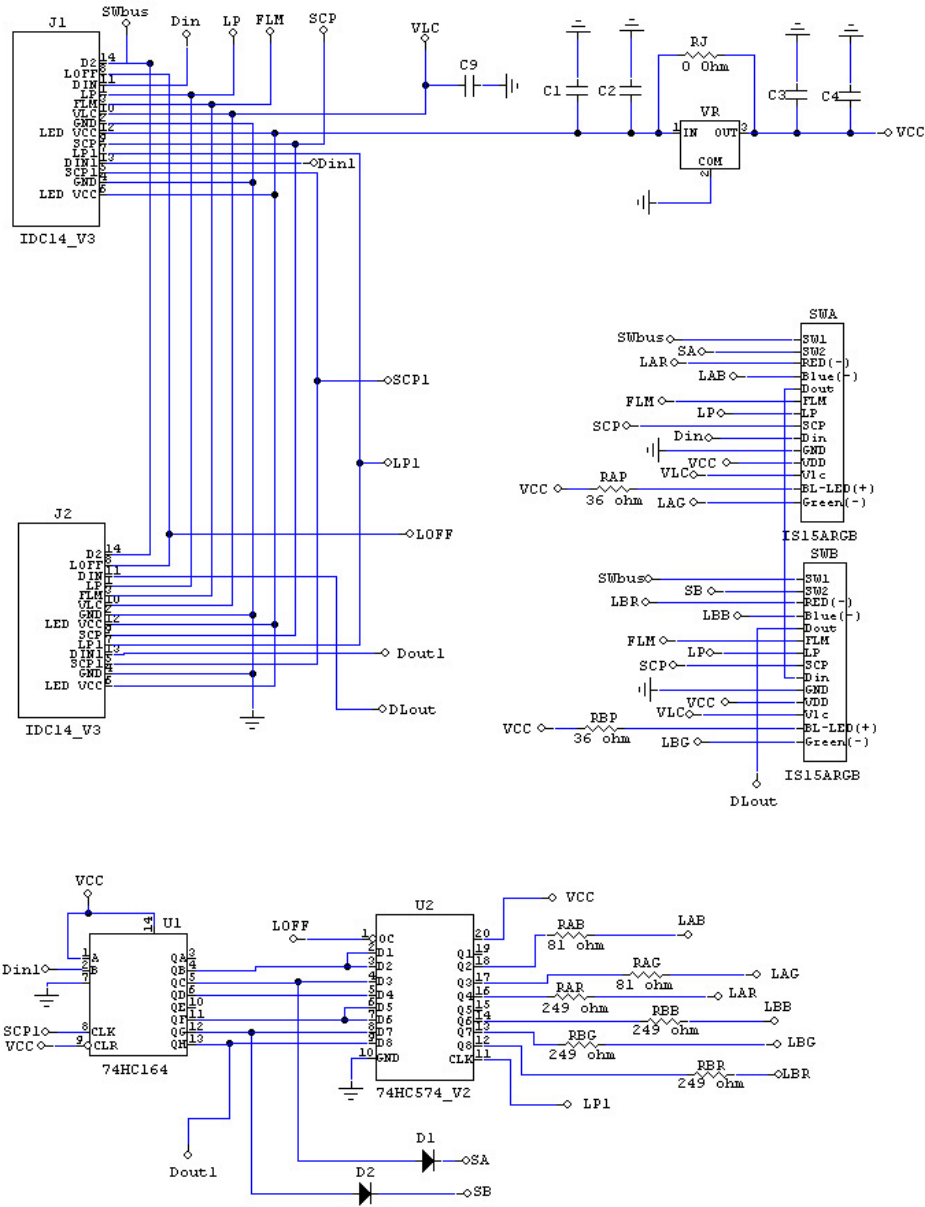

Logic Board Schematic for Two LCD 64x32 RGB SmartSwitch

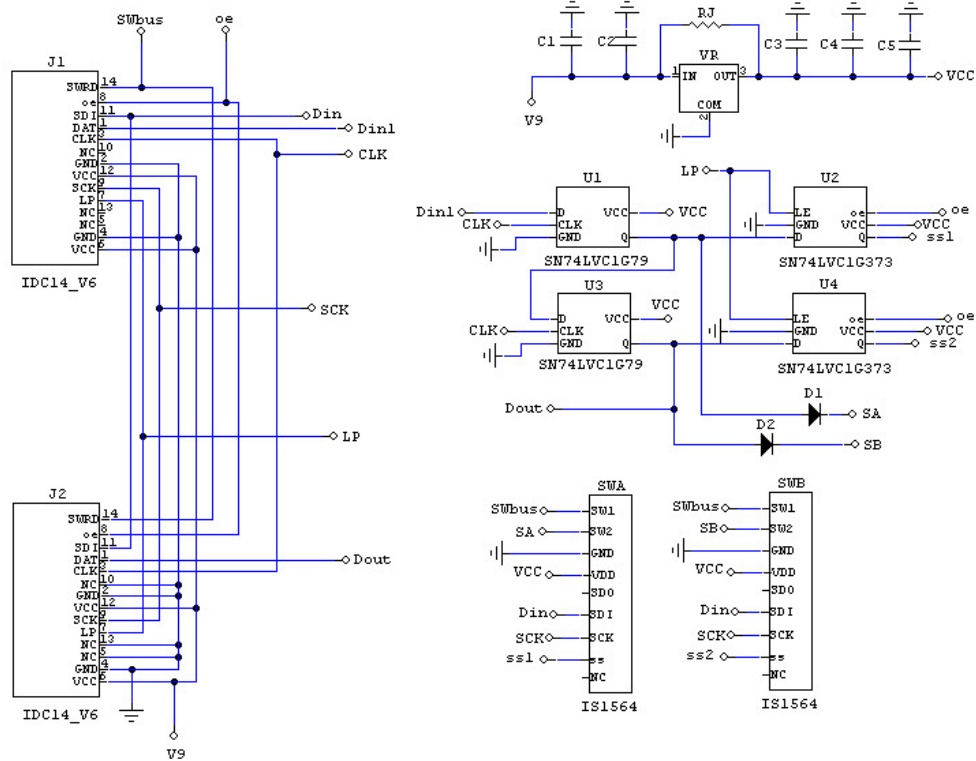

Container size

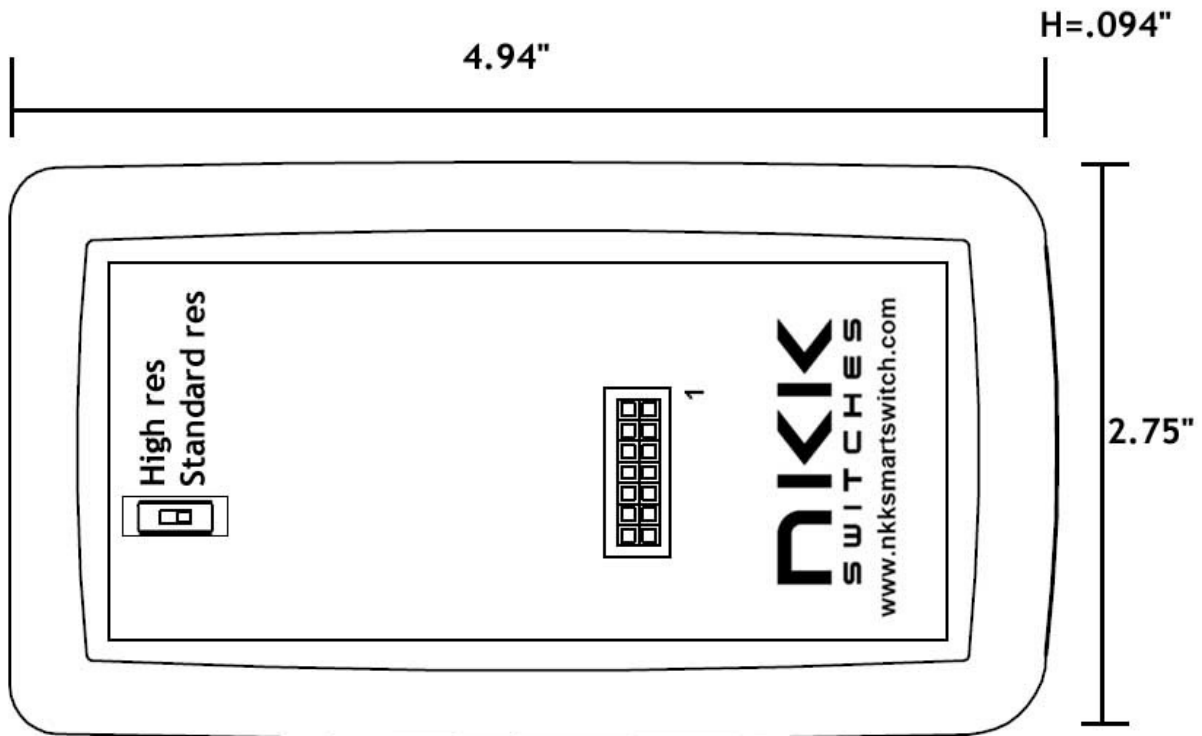

Board photo

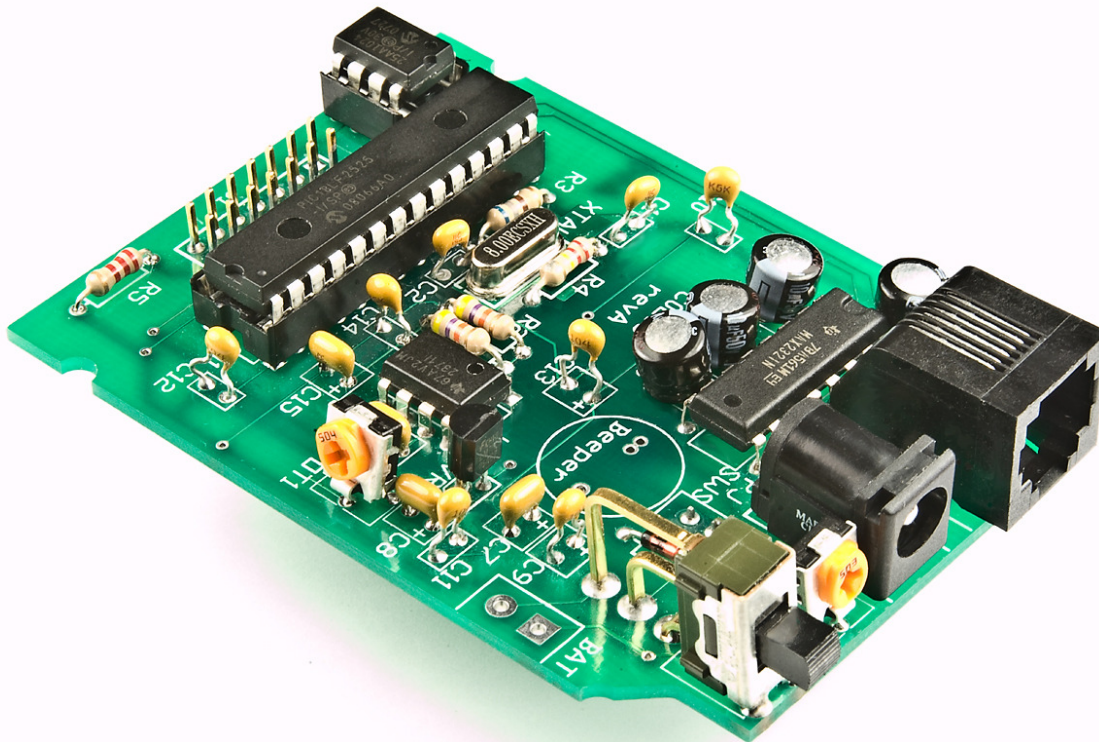

8. Key Terms & Definitions

Module	NKK Switches' LCD SmartSwitches and SmartDisplays.
Host	Any computer, terminal, or other device that can communicate over the RS232 line.
Controller	A PCB assembly that controls one or more logic boards and the switches associated with them. It communicates with a host over the RS232 line.
Logic Board	A PCB assembly with “glue logic” for mounting switches. It is controlled by a controller.
Byte	An eight bit hex value ranging from 00H to FFH (Decimal 0 to 255). The bit format of a byte is: (B7 B6 B5 B4 B3 B2 B1 B0) where B7 is most significant and bit B0 is least significant bit.
Nibble/Hex digit	A four bit value ranging from 0H to FH. A byte consists of two nibbles.
ASCII	A byte value representing a symbol.
Communication Format	<p>There are two formats to transmit a byte:</p> <ol style="list-style-type: none">Hex format - A hex byte is transmitted without any change to it. [xxH] will be used to denote this. All commands and some data are sent by using this format.ASCII HEX format - Each nibble of the byte is converted to ASCII code and sent as a byte. [xxAH] will be used to denote this. For example, the hex byte 5AH is transmitted in two bytes, 35H and 41H. The ASCII value for 5 is 35H and the ASCII value for A is 41H. All addresses and most data are sent using this format.
Address	A one byte value ranging from 01H to FFH representing the 255 memory.

9. Firmware issues

The problems found in the most current version are listed below and will be resolved in the following version.

Version V11

1. Command 29H: LCD 64x32 does not upload complete data.
2. Command 26H 52H 58H: Uploads version 10 instead of current version 11.
3. Command 26H 51H 5DH: Does not work for LCD 36x24 or LCD 64x32.
4. Command 26H 51H 5EH: Does not work for LCD 36x24 or LCD 64x32.



Компания «ЭлектроПласт» предлагает заключение долгосрочных отношений при поставках импортных электронных компонентов на взаимовыгодных условиях!

Наши преимущества:

- Оперативные поставки широкого спектра электронных компонентов отечественного и импортного производства напрямую от производителей и с крупнейших мировых складов;
- Поставка более 17-ти миллионов наименований электронных компонентов;
- Поставка сложных, дефицитных, либо снятых с производства позиций;
- Оперативные сроки поставки под заказ (от 5 рабочих дней);
- Экспресс доставка в любую точку России;
- Техническая поддержка проекта, помощь в подборе аналогов, поставка прототипов;
- Система менеджмента качества сертифицирована по Международному стандарту ISO 9001;
- Лицензия ФСБ на осуществление работ с использованием сведений, составляющих государственную тайну;
- Поставка специализированных компонентов (Xilinx, Altera, Analog Devices, Intersil, Interpoint, Microsemi, Aeroflex, Peregrine, Syfer, Eurofarad, Texas Instrument, Miteq, Cobham, E2V, MA-COM, Hittite, Mini-Circuits, General Dynamics и др.);

Помимо этого, одним из направлений компании «ЭлектроПласт» является направление «Источники питания». Мы предлагаем Вам помощь Конструкторского отдела:

- Подбор оптимального решения, техническое обоснование при выборе компонента;
- Подбор аналогов;
- Консультации по применению компонента;
- Поставка образцов и прототипов;
- Техническая поддержка проекта;
- Защита от снятия компонента с производства.



Как с нами связаться

Телефон: 8 (812) 309 58 32 (многоканальный)

Факс: 8 (812) 320-02-42

Электронная почта: org@eplast1.ru

Адрес: 198099, г. Санкт-Петербург, ул. Калинина, дом 2, корпус 4, литера А.