

125, 250 Watt AC-DC (DC-DC) Converters Convert Select



Features

- RoHS lead-free-solder and lead-solder-exempted products are available
- Rugged 35 mm DIN-rail snap-fit design
- Class I equipment
- Universal AC-input or DC-input (66 – 150 or 90 – 350 VDC) with single stage conversion
- Power factor correction, harmonics IEC/EN 61000-3-2
- Virtually no inrush current
- Immunity to IEC/EN 61000-4-2, -3, -4, -5, -6, -8, -11
- Emissions according to EN 55011/022
- Very high efficiency; up to 89%
- Short-term output peak power capability, rectangular current limiting characteristic
- Single or two independently regulated outputs with 12, 24, 36, or 48 V
- Outputs no-load, overload, and short-circuit proof
- PCBs coated by protective lacquer
- Very high reliability

Safety-approved to IEC/EN 60950-1 and UL/CSA 60950-1 2nd Ed., UL 508 listed components



Description

The Convert Select front end series represents a family of DIN-rail mountable DC-DC and AC-DC converters with power factor correction. The converters have been designed according to the latest industry requirements and standards. The converters are ideal for use in outdoor and other demanding applications to power building control systems, factory automation, industrial controls, instrumentation, electromagnetic drives, fans, and other DC loads. Different models are available with a single output or two independently regulated, electrically isolated outputs with 12, 24, 36, or 48 V. Special models for battery charging are available. The EW

models are particularly suitable for 110 V railway applications; they have been designed in accordance with the railway standards EN 50155 and EN 50121.

Key features of the Convert Select line include power factor correction with low harmonic distortion, negligibly low inrush current, high immunity to transients and surges, and low electromagnetic emissions. Internal protection circuits such as input over- and undervoltage lockout, thermal protection, as well as output overvoltage protection by a second control loop ensure safe operation of the final system.

The outputs deliver an electrically-isolated Safety Extra Low Voltage (SELV) and low output noise. They are no-load,

Table of Contents

	Page	Page	
Description	1	Immunity to Environmental Conditions	16
Model Selection	2	Mechanical Data	17
Functional Description	4	Safety and Installation Instruction	18
Electrical Input Data	6	Description of Options	21
Electrical Output Data	8	Accessories	24
Electromagnetic Compatibility (EMC)	13		

Copyright © 2018, Bel Power Solutions Inc. All rights reserved.

overload, and short-circuit proof. The electronically controlled short-term peak power capability of up to 150% of the rated output power enables the front end converters to deliver additional power to start-up motors or to safely operate subsequent circuit breakers. Built-in large sized output capacitors absorb possible reverse energy, which may be caused by quick deceleration of electromagnetic drives connected directly to the output. A green LED at the front cover displays the status of the output(s).

The Convert Select Series was designed according to all relevant international safety standards. The converters are approved by TÜV and UL, and are UL 508 listed. Adequate clearances and creepage distances allow operation in

pollution degree 3 environment (with AC input). All board assemblies are coated with a protective lacquer.

The thermal concept allows operation at full load up to an ambient temperature of 60 °C (LW models) or 70 °C (EW models) in free air without forced cooling. A rugged DIN snap-fit device allows easy and reliable fixing onto the various 35 mm DIN rail models. The converters are fitted with cage clamp terminals which are easily accessible from the front. System connectors with screw terminals for use with pre-assembled harnesses, external adjustment of the output voltage as well as various auxiliary functions are available as options.

The letter E stands for improved EMC performance of LW models. Models without E are obsolete.

Model Selection

Table 1: Standard models

Output 1		Output 2		Output Power	Operating Input Voltage $V_{i \min} - V_{i \max}$	Type Designation ⁶	Effic. η_{\min} ⁸ [%]	Options ^{3, 5}		
$V_{o1 \text{ nom}}$ ¹ [VDC]	$I_{o1 \text{ nom}}$ [A]	$V_{o2 \text{ nom}}$ ¹ [VDC]	$I_{o2 \text{ nom}}$ [A]	$P_{o \text{ nom}}$ [W]						
12.35	7.5*	-	-	93*	85 ² – 264 VAC, 47 – 63 Hz ⁴ , 90 ² – 350 VDC ⁷	LWR1301-6E ³	83*	R D1, D2, D5 M1, M2 F K2, G		
12.35	14*	-	-	173*		LWN1301-6E ³	83*			
24.7	5	-	-	124		LWR1601-6E	87			
24.7	10	-	-	247		LWN1601-6E	87			
37	3.3	-	-	122		LWR1701-6E ³	88			
37	6.6	-	-	244		LWN1701-6E ³	88			
49.4	2.5	-	-	124		LWR1801-6E	88			
49.4	5	-	-	247		LWN1801-6E	88			
12.35	7*	12.35	7*	173*		LWN2320-6E ³	83*			
24.7	5	24.7	5	247		LWN2660-6E	87			
37	3.3	37	3.3	244		LWN2770-6E ³	89			
49.4	2.5	49.4	2.5	247		LWN2880-6E	89			
24.7	5	-	-	120		66 – 150 VDC	EWR1601-0 ⁹		87	R, M1, M2 Q, K2, G
24.7	5	24.7	5	240			EWN2660-0 ⁹		87	

* Version 106 or higher

¹ R-input not connected.

² For derating at low input voltage see section *Output Power Derating*.

³ For minimum quantity and lead times contact the Company.

⁴ The converters have been tested up to 440 Hz; operation at 16²/₃ Hz is also possible, but the output ripple is slightly higher. For questions when operating at frequencies <47 Hz or >63 Hz, consult the Company.

⁵ On double-output models the options R, M2, D1, D2, D5 are related to the second output only.

⁶ Improved EMC performance for LWN/LWR models. Former models without E are still available on request.

⁷ $V_i \leq 250$ VDC for models with option F

⁸ Min. efficiency at $V_{i \text{ nom}}$, $I_{o \text{ nom}}$, and $T_A = 25$ °C. Typical values are approx. 2% better.

⁹ EWN and EWR models are designed for railway applications according to EN 50155 and EN 50121.

 NFND: Not for new designs.

 Preferred for new designs

Table 2: Battery charger models (M1 included)

V _{Bat} [VDC]	Output Voltage		Nominal Output Values			Operating Input Voltage V _{i min} - V _{i max}	Type Designation ⁶	Effic. ⁶	Options ³	
	V _{o safe} ¹ [VDC]	V _{o max} [VDC]	V _{o nom} ⁵ [VDC]	I _{o nom} ⁵ [A]	P _{o nom} ⁵ [W]				η _{min} ⁸ [%]	
12	12.84 ¹	14.65	13.8	7.5*	104*	85 ² – 264 VAC, 47 – 63 Hz ⁴ , 90 ² – 350 VDC ⁷	LWR1140-6EM1 ³	83*	F	K2, G
				14*	194*					
24	25.68 ¹	29.3	27.3	4.2	115		LWR1240-6EM1	86		
				8.4	230		LWN1240-6EM1	85		
36	38.52 ¹	43.95	40.88	2.8	115		LWR1840-6EM1 ³	86		
				5.6	230		LWN1840-6EM1 ³	86		
48	51.36 ¹	58.6	54.5	2.1	115		LWR1740-6EM1	86		
				4.2	230		LWN1740-6EM1	87		

* Version 106 or higher

¹ Setting voltage (typ.) with open R-input

² For derating at low input voltage, see section *Output Power Derating*.

³ For minimum quantity and lead times, contact the Company.

⁴ The converters have been tested up to 440 Hz; for operating frequency <47 Hz or >63 Hz consult the Company.

⁵ Nominal output figures, calculated with a cell voltage of 2.27 V at 20 °C.

⁶ Improved EMC performance. Former models without E are still available on request.

⁷ V_i ≤ 250 VDC for models with option F.

⁸ Min. efficiency at V_{i nom}, V_{o nom}, I_{o nom}, and T_A = 25 °C. Typical values are approx. 2% better.

Part Number Description

Input voltage range	E, L	_____	L	_____	W	_____	N	_____	2	_____	6	_____	6	_____	-	_____	E	_____	D	_____	2	_____	F	_____	K	_____	2	_____	G
Series	W	_____																											
Nominal output power																													
125 W	R	_____																											
250 W	N	_____																											
Number of outputs	1, 2	_____																											
Type specification	000 – 999	_____																											
Operational ambient temperature range T _A																													
–40 to 60 °C	-6	_____																											
EW or customer-specific	-0, -5	_____																											
Improved EMC performance	E	_____																											
Options																													
Output voltage control input ¹	R	_____																											
Save data signal ¹	D1, D2, D5	_____																											
Multiple functions via D-SUB connector ¹ ..	M1, M2	_____																											
Built-in second fuse, input diode	F, Q	_____																											
System connector	K2	_____																											
RoHS compliant for all six substances	G	_____																											

¹ Only one of these options is possible.

Note: The sequence of options must follow the order above.

NFND: Not for new designs	Preferred for new designs.
---------------------------	----------------------------

Example: LWN2660-6ED2FK2G: Power factor corrected AC-DC converter, operating input voltage range 85 – 264 VAC, 2 electrically isolated and individually regulated outputs, each providing 24.7 V, 5 A, improved EMC performance, options D2, F, K2, and RoHS-compatible for all 6 substances.

Product Marking

Basic type designation, applicable safety approval and recognition marks, CE mark, warnings, pin designation, company logo.

Specific type designation, input voltage range, nominal output voltages and currents, degree of protection, batch no., serial no., and data code including production site, version, and date of production.

Functional Description

The W Series converters are primary controlled AC-DC or DC-DC flyback converters with a constant switching frequency of 130 kHz. The power-factor-corrected single-step conversion of the input voltage to a low output voltage results in extremely high efficiency. Depending upon the output power, the converters are fitted with one (125 W) or two (250 W) powertrains. Models with two powertrains have one or two outputs. Double-output models exhibit individually regulated powertrains.

The input voltage is fed via fuse, filter, and rectifier to the main transformer, designed in planar technique. The input filter with very small input capacitance generates virtually no inrush current. An input transient suppressor protects the converter against high voltage peaks and surges. Input over- and undervoltage lockout as well as input current limitation protect the converter from operation outside of its specification. The input voltage waveform is sensed by the primary control logic to allow active power factor correction, forcing the input current to follow the input voltage waveform.

The secondary side of the main transformer supplies via the rectifier diode a large electrolytic output storage capacitor providing for the hold-up time. Double-output models exhibit an individual control logic each. The output voltage and the output current are measured and fed back to the primary control logic via an optocoupler. A second control loop monitors the output voltage. It disables the output in the case of a failure in the control logic and limits the output voltage.

Built-in temperature sensors monitor the internal temperature of each powertrain. If the temperature exceeds the limit, the converter reduces the output power continuously to keep the temperature below its limit. A green LED on the front cover confirms the presence of the output voltage(s).

The R input (option R, M1, or M2) allows for external adjustment of the output voltage by means of a resistor or an external voltage source. An external sensor can be connected to the R input and allows for temperature-controlled battery charging (see *Accessories*).

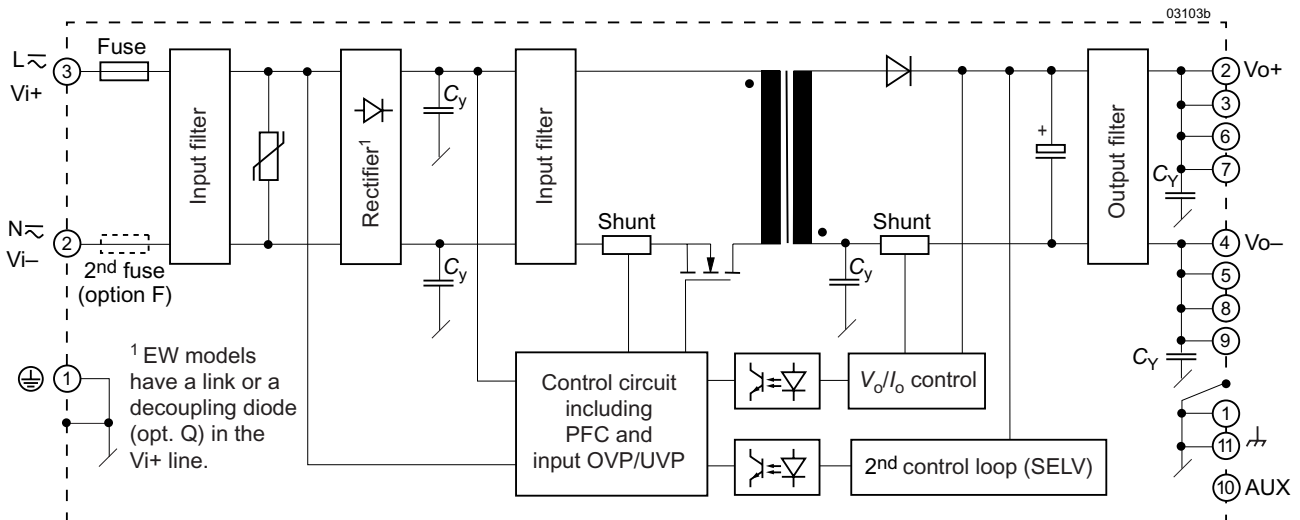

Fig. 1
 Single-output converters (125 W).

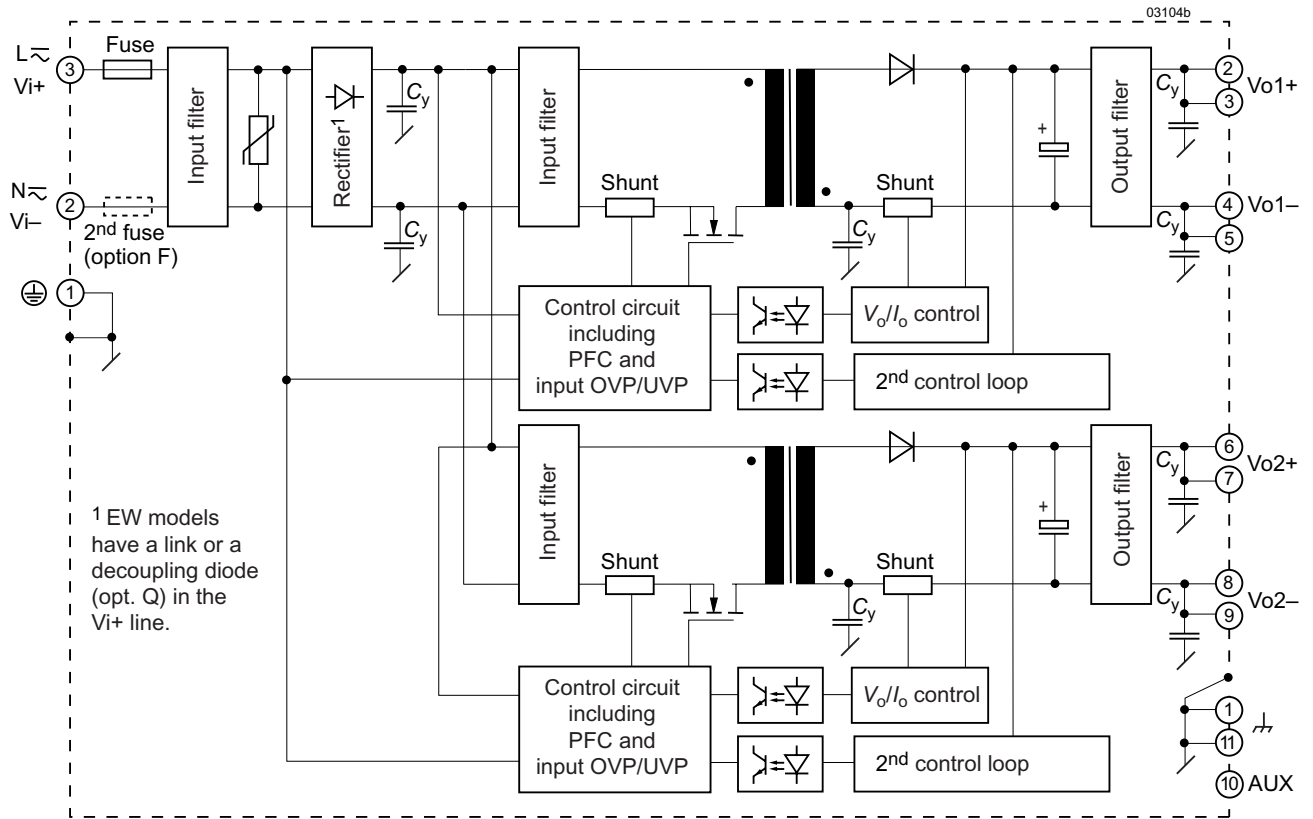

Fig. 2
 250 W converters.
 The figure shows a double-output model.
 For the pinout of 250 W single-output models, see fig. 1 or table 13.

Electrical Input Data

General conditions:

$T_A = 25\text{ °C}$, unless T_C is specified.

Table 4a: Input data of LW models

Input			LWR						LWN						Unit
			AC-Input			DC-Input			AC-Input			DC-Input			
Characteristic		Conditions	min	typ	max	min	typ	max	min	typ	max	min	typ	max	
V_i	Operating input voltage range	$I_o = 0 - I_{o\text{ nom}}$ $T_C - T_{C\text{ max}}$	85 ² 264			90 ² 350 ⁴			85 ² 264			90 ² 350 ⁴			V
$V_{i\text{ nom}}$	Rated input volt. range		100 (230) 240			220			100 (230) 240			220			
f_i	Rated input frequency ¹		50 – 60			--			50 – 60			--			Hz
I_i	Input current	$I_{o\text{ nom}}, V_i = V_{i\text{ nom}}$	0.63			0.65			1.25			1.3			A
		$I_{o\text{ nom}}, V_i = V_{i\text{ min}}$	1.75			1.67			3.5			3.3			
P_{i0}	No-load input power	$V_{i\text{ min}} - V_{i\text{ max}}$	1.2			0.9			1.3			1			W
$I_{i\text{ inrush}}$	Inrush current	$V_{i\text{ max}}, t > 0.1\text{ ms}$	3			3			5			5			A
C_i	Input capacitance		5			5			6			6			µF
PF	Power factor	$V_{i\text{ nom}} = 230\text{ V}, I_{o\text{ nom}}$	0.86 ⁵			--			0.86 ⁵			--			
$V_{i\text{ RFI}}$	Conducted input RFI	EN 55011/55022	A, B ³			A, B ³			A, B ³			A, B ³			
	Radiated input RFI	$V_{i\text{ nom}}, I_{o\text{ nom}}$	B ³			B ³			B ³			B ³			
f_{switch}	Switching frequency		130			130			130			130			kHz

¹ For operating frequencies <47 Hz and >63 Hz consult the Company. The converters have been tested up to 440 Hz.

² Output power derating at low input voltage and/or high case temperature T_C (see *Output power derating*).

³ Models with feature E (type test with LWN1801-6E)

⁴ $V_i \leq 250\text{ VDC}$ for models with option F.

⁵ Models with 12 V output: ≥ 0.70 for LWR, ≥ 0.75 for LWN

Table 4b: Input data of EW models

Input			EWR			EWN			Unit
			DC-Input			DC-Input			
Characteristic		Conditions	min	typ	max	min	typ	max	
V_i	Operating input voltage range	$I_o = 0 - I_{o\text{ nom}}$ T_C to $T_{C\text{ max}}$	66 150 ¹			66 150 ¹			V
$V_{i\text{ nom}}$	Nominal input voltage		110			110			
V_{UVT}	Undervoltage trigger		54 60			54 60			
I_i	Input current	$I_{o\text{ nom}}, V_i = V_{i\text{ nom}}$	1.25			2.5			A
		$I_{o\text{ nom}}, V_i = 66\text{ V}$	2.2			4.4			
P_{i0}	No-load input power	$V_{i\text{ min}} - V_{i\text{ max}}$	0.8			1.3			W
$I_{i\text{ inrush}}$	Inrush current	$V_{i\text{ max}}, t > 0.1\text{ ms}$	6			12			A
C_i	Input capacitance		2.5			4.5			µF
$V_{i\text{ RFI}}$	Conducted input RFI	EN 55011/55022	A			A			
	Radiated input RFI	$V_{i\text{ nom}}, I_{o\text{ nom}}$	--			--			
f_{switch}	Switching frequency		130			130			kHz

¹ $V_i \leq 168\text{ VDC}$ for 3 s. Overvoltage trigger adjusted to 170 – 182 V.

Output Power Derating

The output power of LW models must be decreased at low input voltage and/or powertrain temperature above 125 °C.

The powertrain temperature depends on the output power, the input voltage, and the cooling method. At low input voltage the losses increase. At the maximum specified environment temperature T_A free air convection cooling might be insufficient approaching maximum ambient conditions. As a result, the output power has to be reduced according to the tables below.

Note: The measurements have been made by the approval boards with free air convection cooling according to UL 60950 specified ambient temperature T_A and with the converter built in a cardboard box according to UL 508 and a specified temperature outside the box T_{out} . The tables give a correlation between T_A or T_{out} and the case temperature T_C (measuring point T_C see *Mechanical Data*). For models not specified, please contact the Company.

EW models need no derating.

Table 5a: P_o derating according to UL 60950 at $T_A = 60$ °C, or according to UL 508 at $T_{out} = 50$ °C

Model	P_o nom [W]	T_C max [°C]	Derate below		derate by [W/V]
			V_i [VAC]	V_i [VDC]	
LWR1601-6E	124	80	108	98	-0.67
LWN1601/2660-6E	247	89	125	115	-1.25
LWR1701-6E	122	80	125	115	-1.25
LWN1701-6E	244	90	125	115	-1.25
LWR1801-6E	124	80	98	93	-0.67
LWN1801/2880-6E	247	89	125	115	-1.25

Table 5b: P_o derating according to UL 60950 at $T_A = 50$ °C, or according to UL 508 at $T_{out} = 40$ °C

Model	P_o nom [W]	T_C max [°C]	Derate below		derate by [W/V]
			V_i [VAC]	V_i [VDC]	
LWR1601-6E	124	76	98	no derating	-0.67
LWN1601/2660-6E	247	86	115	105	-1.25
LWR1801-6E	124	76	93	no derating	-0.67
LWN1801/2880-6E	247	86	105	95	-1.25

Input Fuse and Protection

A fast-blow fuse (Schurter F 6.3A, 5 × 20 mm), protected by a sleeve, is connected to the input $L\bar{N}$ or V_i+ . EW models have a smaller fuse (250 V, 4 × 9 mm, SOC NT3 6.3A V009, UL-recognized E-39265). For DC input voltages above 250 V consult the *Installation Instructions*.

Converters with option F have 2 small fuses, one in each input line. Converters with option EF (E and F) have 2 large fuses (F6.3A, 5 × 20 mm). The DC input voltage for converters with option F is limited to 250 V.

A VDR and a symmetrical input filter form an effective protection against input transients.

An under- and an overvoltage lockout protect the converter, which is disabled below $V_{i\ min}$ and above $V_{i\ max}$ by an internally generated inhibit signal.

The built-in bridge rectifier (LW models) provides reverse polarity protection at the input if operated from DC.

EW models are protected by the (blowing) input fuse in connection with the body diode of the main transistor. Option Q offers a serial diode, but this reduces the efficiency by approx. 1%.

Efficiency

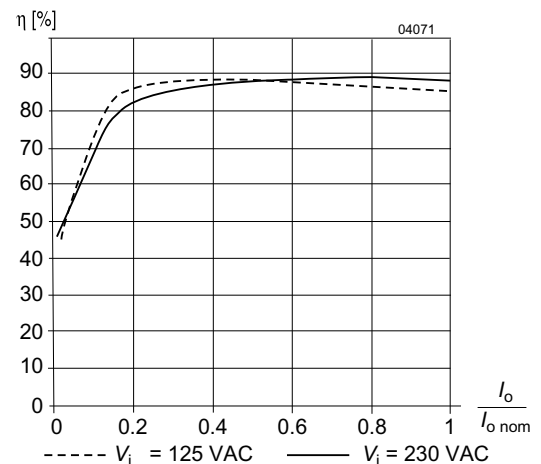

Fig. 3
Efficiency versus load (LWN2660-6)

Power Factor, Harmonics

All converters feature active power factor correction.

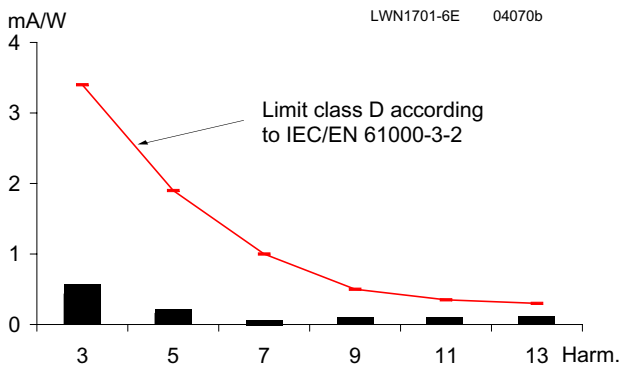

Fig. 4
 Harmonic currents at input current, measured at $V_i = 230$ VAC, $I_o = I_{o\text{ nom}}$ (LWN1701-6E).

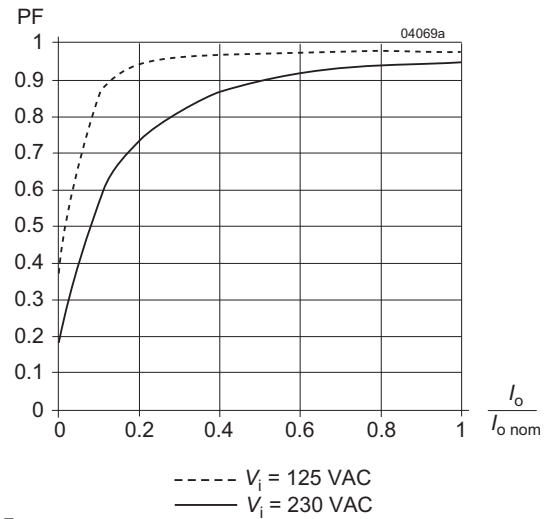

Fig. 5
 Power factor versus load (LWN2660-6)

Electrical Output Data

Table 6a: Output data of 125 Watt standard models. General conditions: $T_A = 25^\circ\text{C}$, unless T_A is specified; R input open-circuit

Model			LWR1301			EWR/LWR1601			LWR1701			LWR1801			Unit
Characteristic		Conditions	min	typ	max	min	typ	max	min	typ	max	min	typ	max	
$V_{o\text{ nom}}$	Output voltage nominal ¹	$V_{i\text{ nom}}, I_{o\text{ nom}}$	12.0			24.25	24.7	25.2	36.4	37	37.8	48.5	49.36	50.4	V
			* 12.2 12.35 12.5			24.55	24.7	24.85	36.8	37	37.2	49.06	49.36	49.66	
$V_{o\text{ worst}}$	Output voltage range of tolerance	$V_{i\text{ min}} - V_{i\text{ max}}, I_o = (0.1 - 1) I_{o\text{ nom}}$	11.9		13.0	24.0		25.8	36.0		38.7	48.0		51.6	
$V_{o\text{ L}}$	Overvoltage protection		14*		15*	28.5		30	42.7		45	57		60	
$P_{o\text{ nom}}$	Nominal output power	$V_i = 100\text{ V} - V_{i\text{ max}}$	105*			124			122			124			W
$I_{o\text{ nom}}$	Output current nominal		7.5*			5.0			3.3			2.5			A
$I_{o\text{ L}}$	Output current limit ³	$V_{i\text{ min}} - V_{i\text{ max}}$	7.6		8.5	5.1		5.7	3.4		3.8	2.53		2.9	
$I_{o\text{ p}}$	Output current boost ⁴	typ. 1 s	11.3			7.5			5.0			3.75			
			-			500			-			-			mV _{pp}
v_o	Ripple and noise	EWR	-			100			100			100			
		LWR	1100 ²			1100 ²			1200 ²			1200 ²			
$\Delta V_{o\text{ u}}$	Static line regulation	$100\text{ V} - V_{i\text{ max}}, I_{o\text{ nom}}$	± 0.08			± 0.1			± 0.15			± 0.15			V
$\Delta V_{o\text{ l}}$	Static load regulation (droop)	$V_{i\text{ nom}}, I_o = (0.1 - 1) I_{o\text{ nom}}$	-0.2			-0.4			-0.6			-0.8			
$v_{o\text{ d}}$	Dynamic load regulation Voltage deviation Recovery time	$V_{i\text{ nom}}, I_o = (0.5 \leftrightarrow 1) I_{o\text{ nom}}$	± 1			± 1.2			± 1.5			± 1.8			ms
			40			40			80			80			
αv_o	Temperature coefficient	$T_{C\text{ min}} - T_{C\text{ max}}$	± 0.02			± 0.02			± 0.02			± 0.02			%/K
$t_{o\text{ r}}$	Start-up time	$V_i = 0 \rightarrow V_{i\text{ nom}}, I_{o\text{ nom}}$	700			700			700			700			ms
$t_{o\text{ h min}}$	Hold-up time	$I_{o\text{ nom}}, V_{o\text{ nom}} \rightarrow 0.8 V_{o\text{ nom}}$	10			6/15			20			25			

* Converters with feature E and version ≥ 106

¹ Setting voltage with open R-input

² Superimposed low frequency ripple at $2 \cdot f_i$

³ Rectangular current limit characteristic (continuous operation)

⁴ Short-term peak power capability 150% of $P_{o\text{ nom}}$ for approx. 1 s

Table 6b: Output data of 250 Watt single-output standard models. General conditions as in table 6a

Model		Conditions	LWN1301			LWN1601			LWN1701			LWN1801			Unit
Characteristic			min	typ	max	min	typ	max	min	typ	max	min	typ	max	
$V_{o\ nom}$	Output voltage nominal ¹	$V_{i\ nom}, I_{o\ nom}$	--			24.25	24.7	25.2	36.4	37	37.8	48.5	49.36	50.4	V
		*	12.2	12.35	12.5	24.55	24.7	24.85	36.8	37	37.2	49.06	49.36	49.66	
$V_{o\ worst}$	Output voltage range of tolerance	$V_{i\ min} - V_{i\ max}, I_{o} = (0.1 - 1) I_{o\ nom}$	11.9		13.0	24.0		25.8	36.0		38.7	48.0		51.6	
$V_{o\ L}$	Overvoltage protection		14*		15*	28.5		30	42.7		45	57		60	
$P_{o\ nom}$	Nominal output power	$V_i = 100\ V - V_{i\ max}$	173*			247			244			247			W
$I_{o\ nom}$	Output current nominal		14*			10			6.6			5.0			A
$I_{o\ L}$	Output current limit ³	$V_{i\ min} - V_{i\ max}$	14.1*		16*	10.2		11.4	6.7		7.6	5.1		5.6	
I_{op}	Output current boost ⁴	typ. 1 s	21			15			10			7.5			
v_o	Ripple and noise	$V_i = 230\ VAC, f_i = 50\ Hz, I_{o\ nom}$	100			100			100			100			mV _{pp}
			1100 ²			1100 ²			1200 ²			1200 ²			
$\Delta V_{o\ u}$	Static line regulation	$100\ V - V_{i\ max}, I_{o\ nom}$	± 0.08			± 0.1			± 0.15			± 0.15			V
$\Delta V_{o\ l}$	Static load regul. (droop)	$V_{i\ nom}, (0.1 - 1) I_{o\ nom}$	-0.2			-0.4			-0.6			-0.8			
v_{od}	Dynamic load regulation Voltage deviation Recovery time	$V_{i\ nom}, I_{o} = (0.5 \leftrightarrow 1) I_{o\ nom}$	± 1			± 1.2			± 1.5			± 1.8			ms
			40			40			80			80			
αv_o	Temperature coefficient	$T_{C\ min} - T_{C\ max}$	± 0.02			± 0.02			± 0.02			± 0.02			%/K
t_{or}	Start-up time	$V_i = 0 \rightarrow V_{i\ nom}, I_{o\ nom}$	700			700			700			700			ms
$t_{oh\ min}$	Hold-up time	$I_{o\ nom}, V_{o\ nom} \rightarrow 0.8 V_{o\ nom}$	10			15			20			25			

Table 6c: Output data of 250 Watt double-output standard models. General conditions as in table 6a

Model		Conditions	LWN2320			EWN/LWN2660			LWN2770			LWN2880			Unit
Characteristic			min	typ	max	min	typ	max	min	typ	max	min	typ	max	
$V_{o1\ nom}$ $V_{o2\ nom}$	Output voltage nominal ¹	$V_{i\ nom}, I_{o\ nom}$	--			24.25	24.7	25.2	37			48.5	49.36	50.4	V
		*	12.2	12.35	12.5	24.55	24.7	24.85	36.8	37	37.2	49.06	49.36	49.66	
$V_{o\ worst}$	Output voltage range of tolerance	$V_{i\ min} - V_{i\ max}, I_{o} = (0.1 - 1) I_{o\ nom}$	11.9		13.0	24.0		25.8	36.0		38.7	48.0		51.6	
$V_{o\ L}$	Overvoltage protection		14*		15*	28.5		30	42.7		45	57		60	
$P_{o\ nom}$	Nominal output power	$V_i = 100\ V - V_{i\ max}$	173*			247			244			247			W
$I_{o\ nom}$	Output current nominal		$2 \times 7^*$			2×5			2×3.3			2×2.5			A
$I_{o\ L}$	Output current limit ³	$V_{i\ min} - V_{i\ max}$	7.1*		7.8*	5.1		5.7	3.4		3.8	2.53		2.9	
I_{op}	Output current boost ⁴	typ. 1 s	$2 \times 10.5^*$			2×7.5			2×5.0			2×3.75			
v_o	Ripple and noise	$V_i = 230\ VAC, f_i = 50\ Hz, I_{o\ nom}$	100			100 ⁵			100			100			mV _{pp}
			1100 ²			1100 ²			1200 ²			1200 ²			
$\Delta V_{o\ u}$	Static line regulation	$100\ V - V_{i\ max}, I_{o\ nom}$	± 0.08			± 0.1			± 0.15			± 0.15			V
$\Delta V_{o\ l}$	Static load regul. (droop)	$V_{i\ nom}, (0.1 - 1) I_{o\ nom}$	-0.2			-0.4			-0.6			-0.8			
v_{od}	Dynamic load regulation Voltage deviation Recovery time	$V_{i\ nom}, I_{o} = (0.5 \leftrightarrow 1) I_{o\ nom}$	± 1			± 1.2			± 1.5			± 1.8			ms
			40			40			80			80			
αv_o	Temperature coefficient	$T_{C\ min} - T_{C\ max}$	± 0.02			± 0.02			± 0.02			± 0.02			%/K
t_{or}	Start-up time	$V_i = 0 \rightarrow V_{i\ nom}, I_{o\ nom}$	700			700			700			700			ms
$t_{oh\ min}$	Hold-up time	$I_{o\ nom}, V_{o\ nom} \rightarrow 0.8 V_{o\ nom}$	10			6/15			20			25			

 * Converters with feature E and version ≥ 106
¹ Setting voltage with open R-input

² Superimposed low frequency ripple at $2 \cdot f_i$
³ Rectangular current limit characteristic (continuous operation)

⁴ Short-term peak power capability 150% of $P_{o\ nom}$ for approx. 1s

⁵ EWN2660: 500 mV @ $V_i = 110\ VDC$

Table 7a: Output data of 125 Watt battery charger models. General conditions: $T_A = 25\text{ }^\circ\text{C}$, unless T_A is specified; R input left open-circuit, unless otherwise specified

Model			LWR1140-6EM1			LWR1240-6EM1			LWR1840-6EM1			LWR1740-6EM1			Unit
Characteristic		Conditions	min	typ	max	min	typ	max	min	typ	max	min	typ	max	
$V_{o\text{ safe}}$	Output setting voltage ¹	$V_{i\text{ nom}}, I_{o\text{ nom}}$	12.25	12.84	13.15	24.5	25.68	26.3	36.75	38.52	39.5	49	51.36	52.6	V
V_{Bat}	Output voltage (max.) controlled by R input	$V_{i\text{ min}} - V_{i\text{ max}}, I_o = (0.1 - 1) I_{o\text{ nom}}$	14.65			29.3			43.95			58.6			
V_{oL}	Overvoltage protection		15.4*		16.3*	30.9		32.5	46		48.8	61.8		65	W
$P_{o\text{ nom}}$	Nominal output power	$V_i = 100\text{ V} - V_{i\text{ max}}$	104*			115			115			115			
$I_{o\text{ nom}}$	Output current nominal		7.5*			4.2			2.8			2.1			A
I_{oL}	Output current limit ³	$V_{i\text{ min}} - V_{i\text{ max}}$	7.6*		8.4*	4.3		4.8	3.2		3.7	2.2		2.5	
I_{op}	Output current boost ⁴	typ. 1 s	11.2*			6.3			4.2			3.2			mV _{pp}
v_o	Ripple and noise	$V_i = 230\text{ VAC}, f_i = 50\text{ Hz}, I_{o\text{ nom}}$	100			100			100			100			
			1100 ²			1100 ²			1200 ²			1200 ²			
$\Delta V_{o\text{ u}}$	Static line regulation	$100\text{ V} - V_{i\text{ max}}, I_{o\text{ nom}}$	± 0.08			± 0.1			± 0.15			± 0.15			V
$\Delta V_{o\text{ l}}$	Static load regulation (droop)	$V_{i\text{ nom}}, I_o = (0.1 - 1) I_{o\text{ nom}}$	-0.2			-0.4			-0.6			-0.8			
v_{od}	Dynamic load regulation Voltage deviation Recovery time	$V_{i\text{ nom}}, I_o = (0.5 \leftrightarrow 1) I_{o\text{ nom}}$	± 1.2			± 1.2			± 1.6			± 1.9			ms
αv_o	Temperature coefficient	$T_{C\text{ min}} - T_{C\text{ max}}$	± 0.02			± 0.02			± 0.02			± 0.02			
t_{or}	Start-up time	$V_i = 0 \rightarrow V_{i\text{ nom}}, I_{o\text{ nom}}$	700			700			700			700			ms

Table 7b: Output data of 250 Watt battery charger models. General conditions as in table 7a

Model			LWN1140-6EM1			LWN1240-6EM1			LWN1840-6EM1			LWN1740-6EM1			Unit
Characteristic		Conditions	min	typ	max	min	typ	max	min	typ	max	min	typ	max	
$V_{o\text{ safe}}$	Output setting voltage ¹	$V_{i\text{ nom}}, I_{o\text{ nom}}$	12.25	12.84	13.15	24.5	25.68	26.3	36.75	38.52	39.5	49	51.36	52.6	V
V_{Bat}	Output voltage (max.) controlled by R input	$V_{i\text{ min}} - V_{i\text{ max}}, I_o = (0.1 - 1) I_{o\text{ nom}}$	14.65			29.3			43.95			58.6			
V_{oL}	Overvoltage protection		15.4*		16.3*	30.9		32.5	46		48.8	61.8		65	W
$P_{o\text{ nom}}$	Nominal output power	$V_i = 100\text{ V} - V_{i\text{ max}}$	194*			230			230			230			
$I_{o\text{ nom}}$	Output current nominal		14*			8.4			5.6			4.2			A
I_{oL}	Output current limit ³	$V_{i\text{ min}} - V_{i\text{ max}}$	14.2*		15.6*	8.6		9.6	6.4		7.4	4.4		5.0	
I_{op}	Output current boost ⁴	typ. 1 s	21*			12.6			8.4			6.3			mV _{pp}
v_o	Ripple and noise	$V_i = 230\text{ VAC}, f_i = 50\text{ Hz}, I_{o\text{ nom}}$	100			100			100			100			
			1100 ²			1100 ²			1200 ²			1200 ²			
$\Delta V_{o\text{ u}}$	Static line regulation	$100\text{ V} - V_{i\text{ max}}, I_{o\text{ nom}}$	± 0.08			± 0.1			± 0.15			± 0.15			V
$\Delta V_{o\text{ l}}$	Static load regulation (droop)	$V_{i\text{ nom}}, I_o = (0.1 - 1) I_{o\text{ nom}}$	-0.2			-0.4			-0.6			-0.8			
v_{od}	Dynamic load regulation Voltage deviation Recovery time	$V_{i\text{ nom}}, I_o = (0.5 \leftrightarrow 1) I_{o\text{ nom}}$	± 1.2			± 1.2			± 1.6			± 1.9			ms
αv_o	Temperature coefficient	$T_{C\text{ min}} - T_{C\text{ max}}$	± 0.02			± 0.02			± 0.02			± 0.02			
t_{or}	Start-up time	$V_i = 0 \rightarrow V_{i\text{ nom}}, I_{o\text{ nom}}$	700			700			700			700			ms

* Converters with feature E and version ≥ 106

¹ Setting voltage with open R-input = $V_{o\text{ safe}}$

² Superimposed low frequency ripple at $2 \cdot f_i$

³ Rectangular current limit characteristic (continuous operation)

⁴ Short-term peak power capability 150% of $P_{o\text{ nom}}$ for approx. 1 s

Parallel Operation

Double-output models exhibit an independent control logic each. Both outputs can be connected in parallel, provided that options S (included in M1) and R are not used, since they influence only the 2nd output. The two power trains share the current due to their output voltage droop characteristic.

Up to 3 converters with the same output voltage may be operated in parallel. It is possible to parallel W Series with X Series converters.

Reasonable current sharing is achieved by the droop characteristic. Correct mode of operation is highly dependent upon the wiring of the converters and the impedance of these wires. Use wires with equal length and equal cross sections of min. 1.5 mm². The best results for parallel operation can be achieved with the wiring shown in fig. 6.

Parallel operation of single-output models using the option R (output voltage adjust) is possible, but not recommended. Refer to fig. 6; the connections between the pins 8 and 9 (both Vo-) should be as short as possible.

Note: Parallel operation is not possible, if a temperature sensor is connected, as the sensor eliminates the output voltage droop.

Note: For ORing diodes, we recommend to use Schottky diodes, mounted on a common heatsink to avoid thermal run away (or the use of double diodes).

Series Connection

Series connection of several outputs up to 150 V is possible. Exceeding an output voltage of 60 V, the output is not SELV.

Output Characteristic and Protection

The output characteristic, individual for each powertrain, is rectangular with a droop to ease parallel operation; see fig. 7.

However, a 50% higher output current is possible for a short time, such allowing start-up of loads or charging of capacitors; see fig. 8.

Each output is independently protected against internal overvoltage by means of a second control loop. When the output voltage exceeds V_{OL} , the respective output is disabled.

Overtemperature Protection

A built-in temperature sensor protects each powertrain is independently protected against overtemperature. When a

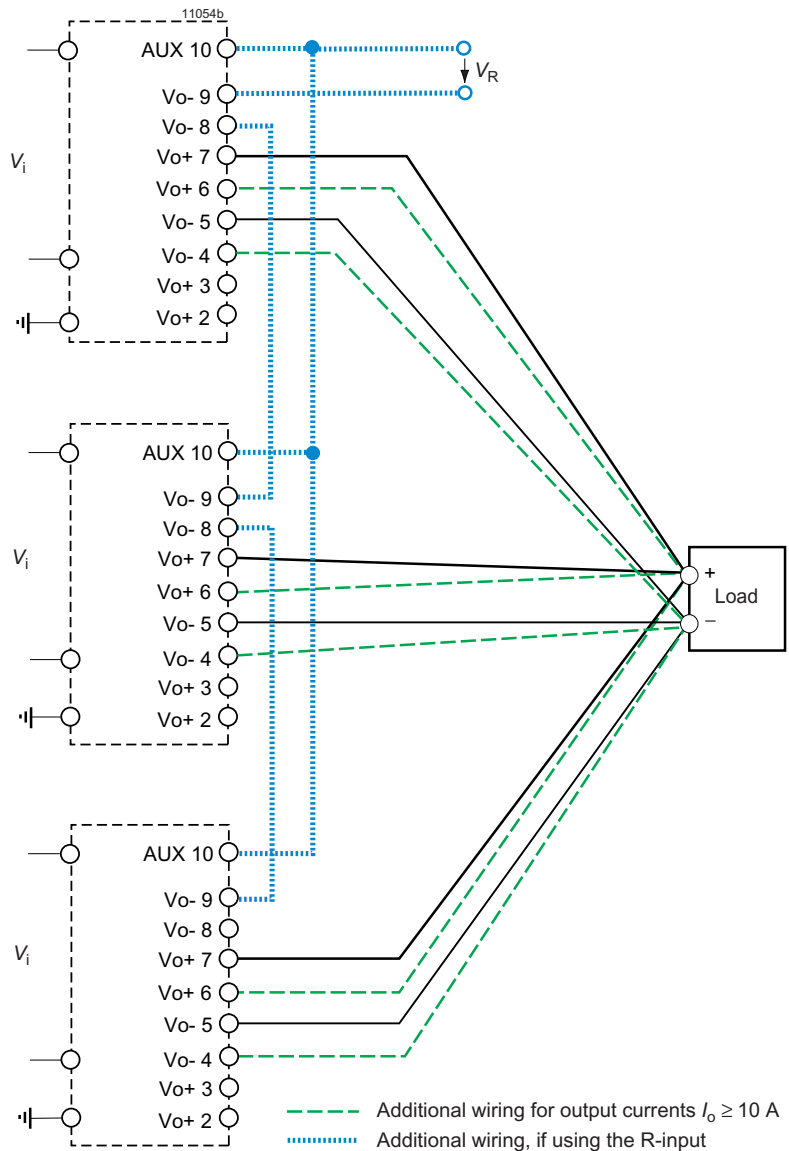
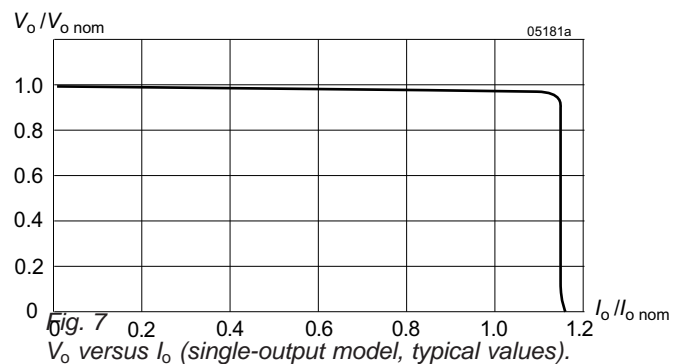

Fig. 6
 Wiring for single-output converters connected in parallel. Additional wiring for higher output currents and with the use of option R is shown.



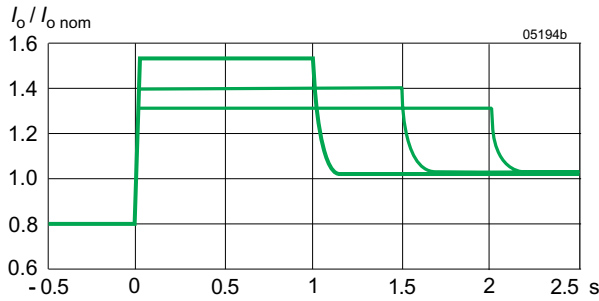

Fig. 8
Short term peak power characteristic: overcurrent versus time (typical values).

certain temperature is reached, the concerned powertrain reduces its output power continuously.

Thermal Considerations

The thermal conditions are influenced by input voltage, output current, airflow, and temperature of surrounding components. $T_{A \max}$ is therefore, contrary to $T_{C \max}$, an indicative value only.

Caution: The installer must ensure that under all operating conditions T_C remains within the limits stated in the table *Temperature specifications*.

Note: Sufficient forced cooling allows T_A to be higher than $T_{A \max}$ provided that $T_{C \max}$ is not exceeded. It is recommended that continuous operation under worst case conditions of the following 3 parameters be avoided: Minimum input voltage, maximum output power, and maximum temperature.

Battery Charging and Temperature Sensor

The battery charger models exhibit the option M1 and have been designed to charge lead-acid batteries. The R-input

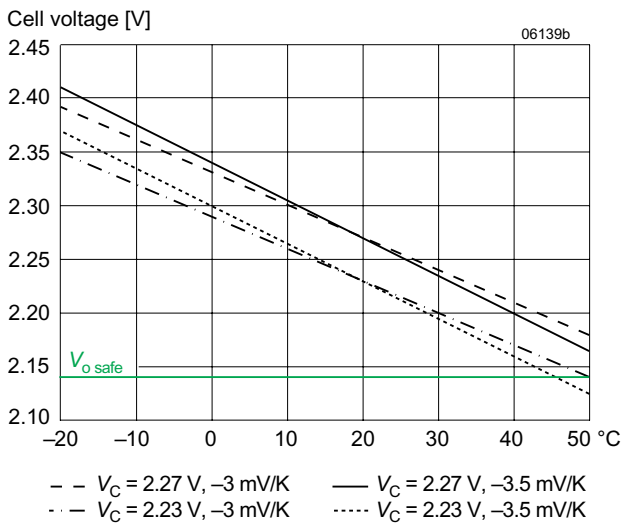

Fig. 9
Trickle charge voltage versus temperature for different temperature coefficients ($V_{o \text{ safe}}$ with disconnected sensor)

allows for connecting a battery-specific temperature sensor, which provides temperature controlled adjust of the trickle charge voltage. This optimizes charging as well as battery life time. Depending upon the cell voltage and the temperature coefficient of the battery, different sensor types are available; see *Accessories*.

Note: Parallel operation is not possible, if the temperature sensor is connected to the paralleled outputs V_{o+} , as the sensor eliminates the output voltage droop.

However, it is possible to insert bleeding resistors in the V_{o+} output lines of each converter in order to create a droop of approx. 0.6 V @ $I_{o \text{ nom}}$ for 24 V outputs (1.2 V @ $I_{o \text{ nom}}$ for 48V outputs), but this creates considerable power losses.

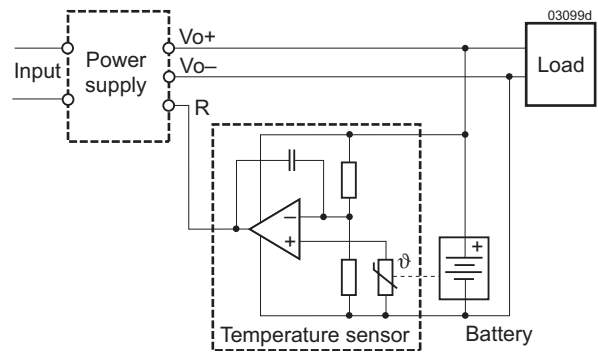

Fig. 10
Schematic circuit diagram of a system with battery backup and temperature-controlled charging.

Electromagnetic Compatibility (EMC)

Electromagnetic Immunity

The W Series has been successfully tested to the following specifications:

Table 8: Electromagnetic immunity (type tests)

Phenomenon	Standard	Level	Coupling mode ¹	Value applied	Waveform	Source impeded.	Test procedure	In oper.	Perf. criter. ²
Electrostatic discharge (to case)	IEC/EN 61000-4-2	4 ³	contact discharge	8000 V _p	1/50 ns	330 Ω	10 positive and 10 negative discharges	yes	A
			air discharge	15000 V _p					
Electromagnetic field RF	IEC/EN 61000-4-3	3 ⁴	antenna	10 V/m ⁴	AM 80%, 1 kHz sinusoidal	n.a.	80 – 1000 MHz	yes	A
	ENV 50204	3	antenna	10 V/m	50% duty cycle, 200 Hz repet. frequ.	n.a.	900 ±5 MHz	yes	A
	IEC/EN 61000-4-3 (EW models)	5	antenna	20 V/m	80% AM, 1 kHz sinusoidal	n.a.	800 – 1000 MHz	yes	A
10 Vm	1400 – 2100 MHz								
5 V/m	2100 – 2500 MHz								
Electrical fast transients/burst	IEC/EN 61000-4-4	3	capacitive, o/c	±2000 V _p	bursts of 5/50 ns, 5 kHz over 15 ms, burst period: 300 ms	50 Ω	60 s positive + 60 s negative transients per coupling mode	yes	A
		3 ⁶	±i/c, +i/-i direct coupling	±2000 V _p ⁶					
Surges	IEC/EN 61000-4-5	3 ⁷	+i/c, -i/c	±2000 V _p	1.2/50 μs	12 Ω	5 pos. and 5 neg. surges per coupling mode	yes	B
			+i/-i	±1000 V _p	1.2/50 μs	2 Ω			
Conducted disturbances	IEC/EN 61000-4-6	3 ⁸	i, o, signal wires	10 VAC (140 dBμV)	AM 80% 1 kHz	150 Ω	0.15 – 80 MHz	yes	A
Powerfrequency magnetic field	IEC/EN 61000-4-8	--	--	100 A/m	50 and 60 Hz	--	x, y, and z axis	yes	A
Surges (EW models)	IEC/EN 50155:2001	wave A ⁹	+i/c, -i/c	1800 V _p	5/50 μs	5 Ω	5 pos. and 5 neg. pulses	yes	B

¹ i = input, o = output, c = case.

² A = Normal operation, no deviation from specifications, B = Normal operation, temporary loss of function or deviation from specs. possible.

³ Exceeds EN 50121-3-2:2006 table 9.3 and EN 50121-4:2006 table 1.4.

⁴ EW models: 20 V/m, which corresponds to EN 50121-3-2:2006 table 9.1 and exceeds EN 50121-4:2006 table 1.1.

⁵ EW models only. Corresponds to EN 50121-3-2:2006 table 9.2 and EN 50121-4:2006 table 1.2 (compliance with digital mobile phones).

⁶ Corresponds to EN 50121-3-2:2006 table 7.2 and EN 50121-4:2006 table 2.2.

⁷ Complies with EN 50121-3-2:2006 table 7.3 and EN 50121-4:2006 table 2.3.

⁸ Corresponds to EN 50121-3-2:2006 table 8.1 and EN 50121-4:2006 table 3.1 (radio frequency common mode).

⁹ Corresponds to EN 50121-3-2:2000. Covers EN 50155:1995, RIA12, direct transients, waveform D (EW models only).

Emissions

Table 9: Electromagnetic emissions for LW models with feature E: (type tests with LWN1801-6E)

Phenomenon	Standards	Conditions	Results
Harmonics	EN 61000-3-2:2006	$V_i = 230\text{ V}$, $V_{o\text{ nom}}$, $I_{o\text{ nom}}$	Class A, D
Voltage fluctuation and flicker	EN 61000-3-3 + A2:2005	$V_i = 230\text{ V}$, $V_{o\text{ nom}}$, $I_{o\text{ nom}}$	Complied

Note: An external toroid ferrite core across the input lines reduces the emissions considerably.

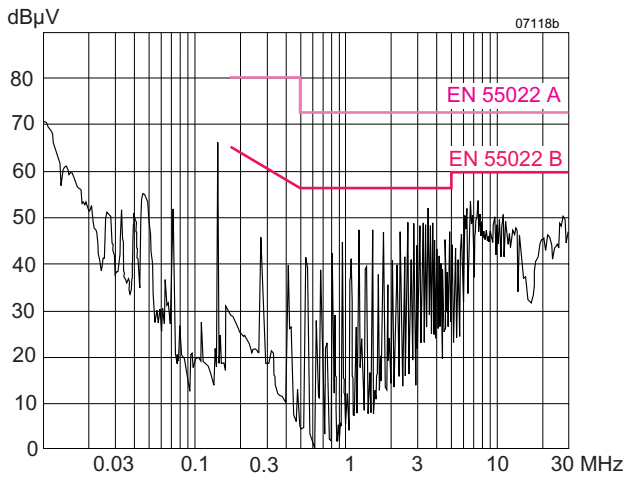

Fig. 11a
 Conducted emissions for LW models without feature E: Typical disturbances (quasi-peak) at the input according to EN 55022, measured at $V_{i\text{ nom}}$ and $I_{o\text{ nom}}$.

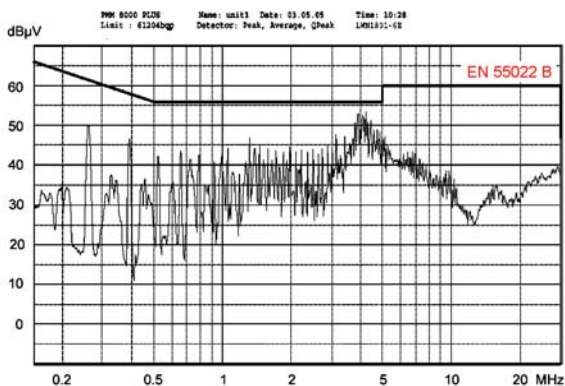

Fig. 12a
 Conducted emissions of LW models with feature E: Disturbances (quasi-peak) at the phase input according to EN 55022, measured at $V_{i\text{ nom}}$ and $I_{o\text{ nom}}$. (LWN1801-6E)

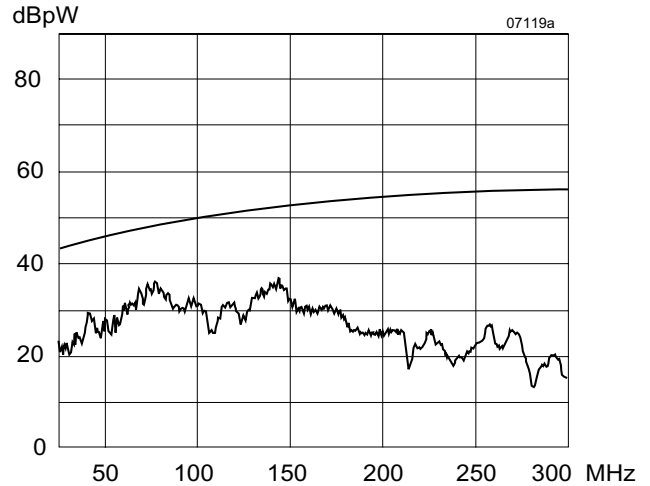

Fig. 11b
 Radiated emissions for LW models without feature E: Typical electromagnetic field strength (quasi-peak) according to EN 55014, measured at $V_{i\text{ nom}}$ and $I_{o\text{ nom}}$.

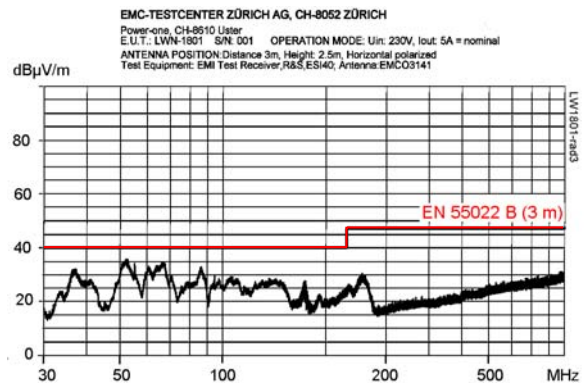

Fig. 12b
 Radiated emissions measured according to EN 55022:2001 for LW models with feature E (LWN1801-6E, antenna 3 m distance, horizontal polarized)

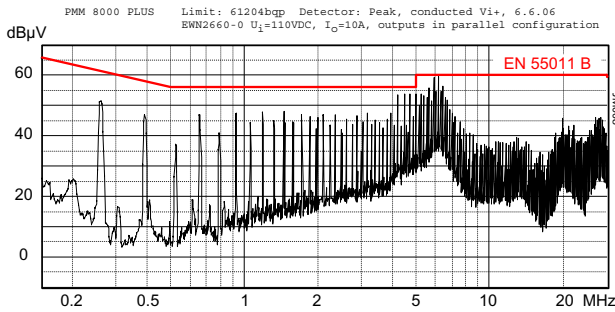

Fig. 13a
Conducted emissions of EW models:
Disturbances (peak) at the phase input according to EN 55011,
measured at $V_{i\text{ nom}}$ and $I_{o\text{ nom}}$. (EWN2660-0)

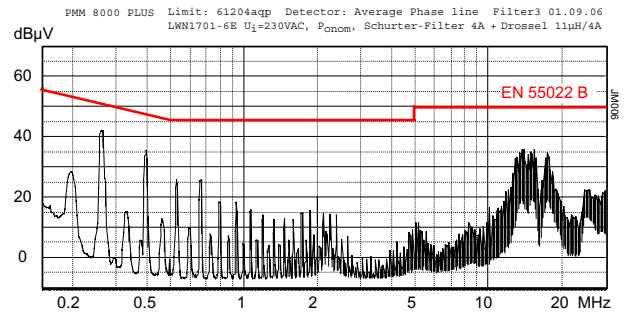

Fig. 14b
Conducted disturbances (average) of LW models (feature E)
with external filter at phase input according to EN 55011/
55022, at $V_i = 230\text{ VAC}$, $I_{o\text{ nom}}$ (LWN1701-6E).



Fig. 13b
Radiated emissions of EW models, measured at $V_{i\text{ nom}}$, $I_{o\text{ nom}}$,
accord.to EN 55011, antenna 3 m distance, (EWN2660-0)

Fig. 14a and 14b show the conducted emissions smoothed by an external filter. The standards EN 55011 and 55022 define limits for conducted (quasi)peak and conducted average emissions. In general the limits for average emissions are more difficult to meet.

The figure below shows the used external filter configuration consisting of the inlet filter KMF1.1241.11 (4 A, Schurter www.schurter.com) and the decoupling choke EPCOS B82111B0000C018, 11 µH, 4 A, 6 × 20 mm.

Note: This filter allows for connection of an IEC inlet and is available with 1 or 2 incorporated fuses.

A similar filter with AMP terminals (6.3 × 20 mm) is also available (Schurter FMLB 5500.2028).

External EMC Filter for Models with Feature E

An external EMC filter can be connected to the inputs lines of the converter. However, a small choke has to be included in the phase line to avoid interferences between the internal and external filter, which would cause dramatically increased low harmonics.

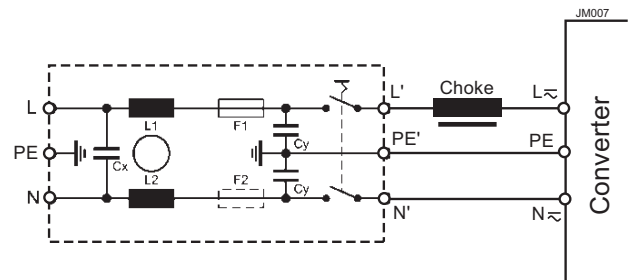

Fig. 15a
External filter to reduce conducted emissions of LW models
with feature E ($L_1 = L_2 = 1.6\text{ mH}$, $C_x = 47\text{ nF}$,
 $C_y = 2.2\text{ nF}$)

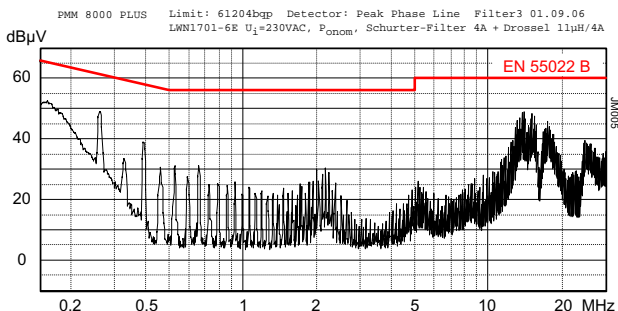

Fig. 14a
Conducted disturbances (peak) of LW models (feature E)
with external filter at phase input according to EN 55011/
55022, at $V_i = 230\text{ VAC}$, $I_{o\text{ nom}}$ (LWN1701-6E).



Fig. 15b
External inlet filter

Immunity to Environmental Conditions

Table 10: Mechanical stress and climatic

Test method		Standard	Test conditions		Status		
Cab	Damp heat steady state	IEC/EN 60068-2-78 MIL-STD-810D sect. 507.2	Temperature:	40 ±2 °C	Converter not operating		
			Relative humidity:	93 ^{+2/-3} %			
			Duration:	56 days			
Kb	Salt mist, cyclic (sodium chloride NaCl solution)	IEC/EN 60068-2-52	Concentration:	5% (30 °C)	Converter not operating		
			Duration:	2 h per cycle			
			Conditions:	40 °C, 93% rel. humidity			
			Storage duration:	3 cycles of 22 h			
Eb	Bump (half-sinusoidal)	IEC/EN 60068-2-29 MIL-STD-810D sect. 516.3	Acceleration amplitude:	25 g _n = 245 m/s ²	Converter not operating, wall-mounted ¹		
			Bump duration:	11 ms			
			6000 bumps:	1000 in each direction	Converter not operating, on DIN-rail ²		
			Acceleration amplitude:	10 g _n = 98.1 m/s ²			
			Bump duration:	11 ms			
			6000 bumps:	1000 in each direction			
Fc	Vibration (sinusoidal)	IEC/EN 60068-2-6 MIL-STD-810D sect. 514.3	Acceleration amplitude and frequency (1 Octave/min):	0.35 mm (10 – 60 Hz)	Converter operating, wall-mounted ¹		
			Test duration:	5 g _n = 49 m/s ² (60 – 2000 Hz)			
						7.5 h (2.5 h each axis)	Converter operating, on DIN-rail ²
						Acceleration amplitude and frequency (1 Octave/min):	
			0.25 mm (10 – 60 Hz)				
			2 g _n = 19 m/s ² (60 – 2000 Hz)				
			7.5 h (2.5 h each axis)				
Ea	Shock (half-sinusoidal)	IEC/EN 60068-2-27 MIL-STD-810D sect. 516.3	Acceleration amplitude:	50 g _n = 490 m/s ²	Converter not operating, wall-mounted ¹		
			Bump duration:	11 ms			
			Number of bumps:	18 (3 in each direction)			
--	Shock	EN 50155/EN 61373 ³ sect. 10, class A and B body mounted ⁴	Acceleration amplitude:	5.1 g _n	Converter operating, on DIN-rail ²		
			Bump duration:	30 ms			
			Number of bumps:	18 (3 in each direction)			
Fh	Random vibration broad band, digital control and guidance	IEC/EN 60068-2-64	Acceleration spectral density:	0.05 g _n ² /Hz	Converter operating, wall-mounted ¹		
			Frequency band:	8 – 500 Hz			
			Acceleration magnitude:	4.9 g _{n rms}			
			Test duration:	3 h (1 h each axis)			
Fda	Random vibration wide band, high reproducibility	IEC/EN 60068-2-35	Acceleration spectral density:	0.01 g _n ² /Hz	Converter operating, mounted on a DIN-rail ²		
			Frequency band:	20 – 500 Hz			
			Acceleration magnitude:	2.2 g _{n rms}			
			Test duration:	1.5 h (0.5 h each axis)			
--	Simulated long life time testing at increased random vibration levels	EN 50155/EN 61373 ³ sect. 8 and 9, class B body mounted ³	Acceleration spectral density:	0.01 g _n ² /Hz	Converter operating, mounted on a DIN-rail ²		
			Frequency band:	5 – 150 Hz			
			Acceleration magnitude:	0.8 g _{n rms}			
			Test duration:	1.5 h (0.5 h each axis)			

¹ Wall-mounted with brackets UMB-W [HZZ00618]; see *Accessories*

² Fastened on a DIN-rail with 2 additional DIN-rail fixing brackets DMB-EWG, see *Accessories*. This covers also wall-mounting with brackets, because wall mounting performs better in vibration test.

³ EW models (railway standards)

⁴ Body mounted = chassis of a railway coach

Temperatures

Table 11: Temperature specifications, valid for an air pressure of 800 - 1200 hPa (800 - 1200 mbar)

Model		LW models -6		EW models -0		Unit	
Characteristics	Conditions	min	max	min	max		
T _A	Ambient temperature	Converter operating ¹	-40	60	-40	70 ³	°C
T _C	Case temperature		-40	90 ²	-40	90 ³	
T _S	Storage temperature	Not operating	-40	100	-40	100	

¹ See *Thermal Considerations*

² See table 5 P_o derating

³ Mounted in vertical position

Failure Rates

Table 12: MTBF

Values at specified case temperature	Module types	Ground benign 40 °C		Ground fixed 40 °C 70 °C		Ground mobile 50 °C	Unit
		MTBF ¹	LWR1601 LWN1601 LWN2660	892 000 644 000 522 000	180 000 131 000 101 000	197 000 72 000 55 000	

¹ Calculated in accordance with MIL-HDBK-217E, notice 2.

Mechanical Data

Dimensions in mm.

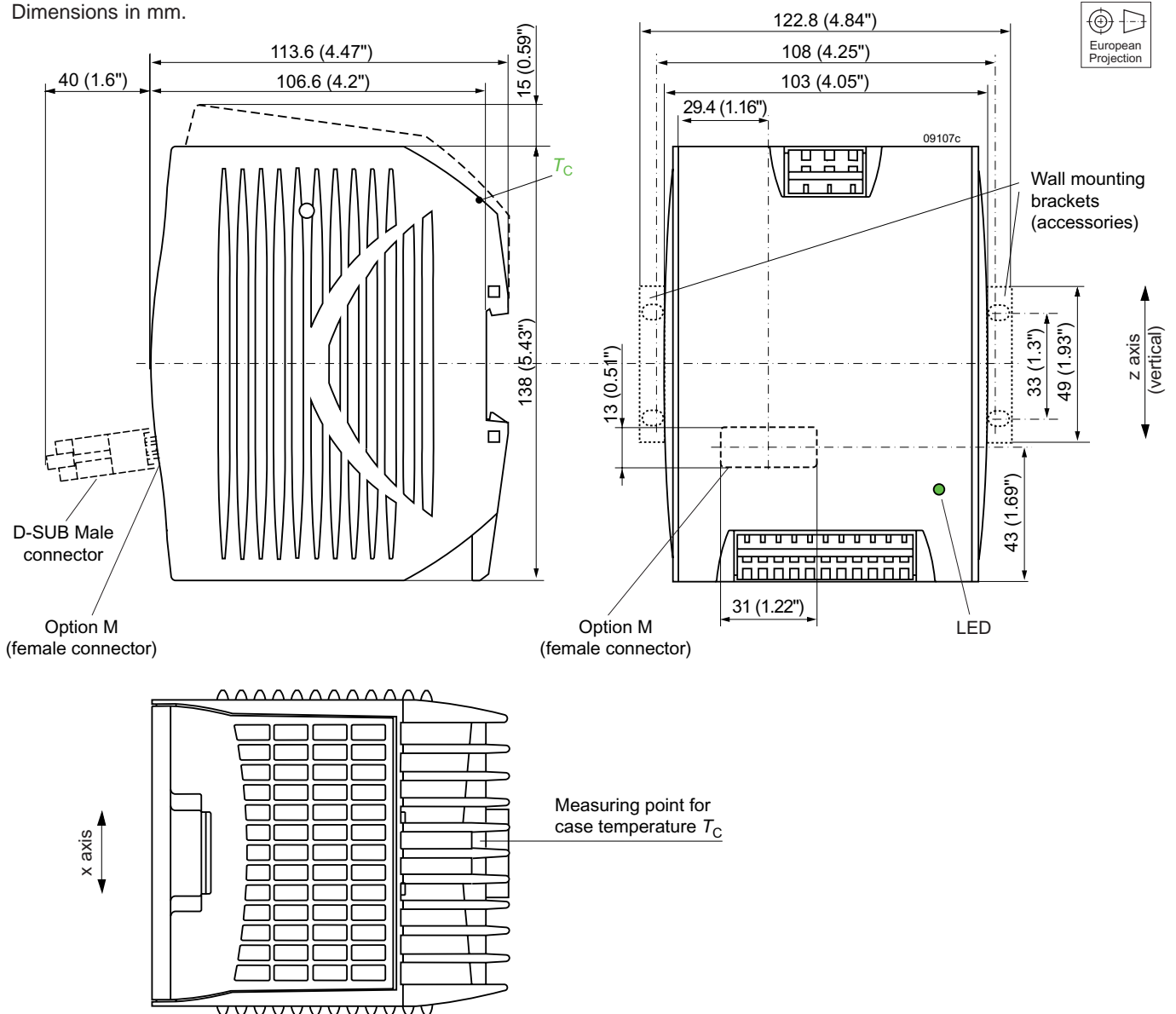

Fig. 16

Case W01

EWN/LWN: weight approx. 1400 g

EWR/LWR: weight approx. 1200 g

Case designed by ATP, Munich.

Safety and Installation Instructions

Terminal Allocation

The terminal allocation tables define the electrical potential of the converters.

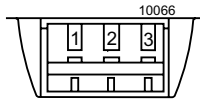

Fig. 17a
View of the input terminals (cage clamp style)

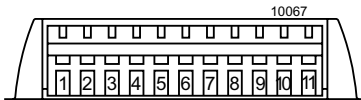

Fig. 17b
View of the output terminals (cage clamp style)

Table 13a: Input terminals of LW models

Pin no.	Pin designation	Electrical determination
1	\oplus	Protective earth PE
2	N \sim	Input neutral, DC negative
3	L \sim	Input phase, DC positive

Table 13b: Input terminals of EW models

Pin no.	Pin designation	Electrical determination
1	\oplus	Protective earth PE
2	Vi-	Input negative
3	Vi+	Input positive

Table 13c: Terminal allocation output side

Pin no.	Pin des.	Single output	Double output
1	\uparrow	Functional earth to load	Functional earth to load
2	+	Output positive	Output 1 positive
3	+	Output positive	Output 1 positive
4	-	Output negative	Output 1 negative
5	-	Output negative	Output 1 negative
6	+	Output positive	Output 2 positive
7	+	Output positive	Output 2 positive
8	-	Output negative	Output 2 negative
9	-	Output negative	Output 2 negative
10	AUX	Option	Option
11	\uparrow	Functional earth to load	Functional earth to load

Installation Instructions

The converters of the W Series are components, intended exclusively for inclusion within other equipment by professional installers. Installation must strictly follow the national safety regulations in compliance with the enclosure, mounting, creepage, clearance, casualty, markings and segregation requirements of the end-use application.

DIN-rail mounting is possible with the built-in snap-fit device on a DIN-rail. This fulfills the mechanical transport requirements as per ETSI 300019-1-2, class 2 (vertical).

To fulfill the requirements of IEC 721-3-2, class 2.1 (vertical), 2 additional fixing brackets HZZ00624-G (see *Accessories*) must be fitted on the bottom side of the DIN-rail. For heavy duty railway applications, we recommend installing all 4 fixing brackets HZZ00624-G.

Chassis or wall mounting is possible using the universal chassis-mounting brackets HZZ00618-G (see *Accessories*). Such installation complies with IEC 721-3-2, class 2.2 (vertical and horizontal).

Caution: Install the converters vertically, and make sure that there is sufficient airflow available for convection cooling. The minimum space to the next device should be: top/bottom: 30 mm, left/right: 20 mm.

The converters of the W Series are class I equipment: Input terminal 1 (\oplus) and the output terminals 1 and 11 (\uparrow) are reliably connected to the case. For safety reasons it is essential

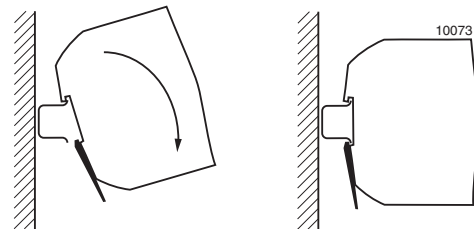

Fig. 18a
Snap-fit mounting to DIN-Rail.

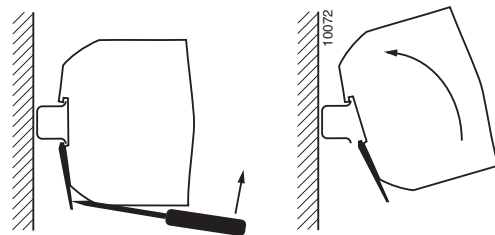

Fig. 18b
Dismounting from DIN-rail. Use proper tool (min. 3 mm screwdriver) and adequate force.

to connect the input terminal 1 (\oplus) with protective earth. Output terminals 1 and 11 can be used to connect the output voltage(s) or the load to functional earth.

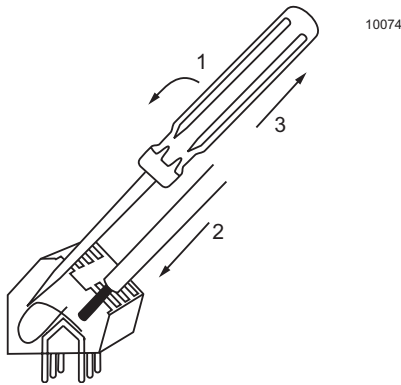

Fig. 19
Cage clamp terminals. Use 0.5 to 2.5 mm² (AWG 20 to 12) solid or stranded wires depending on local requirements.

The phase input ($L\sim$ or V_i+) is internally fused; see *Input Fuse*. This fuse is designed to break an overcurrent in case of a malfunction of the converter and is not customer-accessible.

External fuses in the wiring to one or both input lines ($L\sim$ and/or $N\sim$) may be necessary to ensure compliance with local requirements. A built-in second fuse in the neutral path is available as option F.

A second fuse in the wiring to the neutral terminal $N\sim$ or option F is needed if:

- Local requirements demand an individual fuse in each source line
- Neutral and earth impedance is high or undefined
- Phase and neutral of the mains are not defined or cannot be assigned to the corresponding terminals ($L\sim$ to phase and $N\sim$ to neutral).

Models with Option F: Caution! Double-pole/neutral fusing.

If the converters operate at source voltages above 250 VDC, an external fuse or a circuit breaker at system level should be installed.

Caution:

- Installation must strictly follow the national safety regulations.
- Do not open this apparatus!

Protection Degree and Cleaning Liquids

The protection degree of the converters is IP 20. Protective covers over input and output terminals are available on request; see *Accessories*.

Any penetration of liquid or foreign solid objects is to be prevented, since the converters are not hermetically sealed.

Standards and Approvals

The converters of the LW Series with feature E were safety-approved to EC/EN 60950-1 and UL/CSA 60950-1 2nd Ed. (models without E: IEC/EN 60950), IEC 61010-1:C11:2002

(models without E: IEC 61010-1), and EN 50178:1997 (with and without E).

The converters are UL508-listed components.

The EW models are safety-approved to IEC/EN 60950-1 and UL/CSA 60950-1 2nd Ed.

The converters have been designed in accordance with said standards for:

- Class I equipment
- Power supply for building-in, vertical mounting on 35 mm DIN-rail or on a wall
- Overvoltage category II (III for 110 VAC supply)
- Basic insulation between input and case, based on 250 VAC
- Double or reinforced insulation between input and output, based on 250 VAC and 350 VDC.
- Functional insulation between outputs and case.
- Functional insulation between outputs.
- Pollution degree 3 environment (AC-input) and degree 2 (DC input).

The converters are subject to manufacturing surveillance in accordance with the above mentioned standards and with ISO9001:2000.

Operation at Frequencies Greater 60 Hz

The LW Series converters have been tested for operation up to 440 Hz. However, the Y and X caps are not approved to such frequency. The leakage currents are higher than at 60 Hz, whereas the output ripple voltage is lower.

Leakage Currents with AC Supply

Leakage currents flow due to internal leakage capacitance and RFI suppression Y-capacitors. The current values are proportional to the mains voltage and nearly proportional to the mains frequency. They are specified at maximum operating input voltage where phase, neutral, and protective earth are correctly connected as required for class I equipment.

Leakage current may exceed 3.5 mA, if $f_i > 63$ Hz.

Railway Applications

The W Series converters have been designed observing the railway standards EN 50155 and EN 50121. All boards are coated with a protective lacquer.

The EW Series is particularly suitable for connection to 110 V railway batteries.

Table 14: Isolation

Characteristic		Input to case and output(s)	Output(s) to case	Output 1 to output 2 and AUX	Unit
Electric strength test	Factory test ≥ 1 s	2.8 ¹	1.4	0.5	kVDC
	AC test voltage equivalent to factory test	2.0	1.0	0.35	kVAC
Insulation resistance		>300 ²	>300 ²	>100	M Ω

¹ In accordance with IEC/EN 60950-1, subassemblies are pretested with 4.2 kVDC.

² Tested at 500 VDC.

Isolation

The electric strength test is performed in the factory as routine test in accordance with EN 50514 and IEC/EN 60950 and should not be repeated in the field. The Company will not honor warranty claims resulting from incorrectly executed electric strength field tests.

Safety of Operator-Accessible Output Circuits

If the output circuit of a converter is operator accessible, it shall be a SELV circuit according to IEC/EN 60950 related safety standards.

The converters have SELV output circuits up to an output voltage of 57.5 V. However, if the isolated outputs are connected to another voltage source or connected in series with a total of >57.5 V the outputs are hazardous.

It is the sole responsibility of the installer to ensure the compliance with the relevant and applicable safety regulations.

LED Indicator

A green LED is activated, when the output voltage V_o is within the normal operating tolerance band.

Note: This LED is also activated, when the converter is not powered by the input, but a loaded battery is connected to the output.

Description of Options

E designates LW models with improved EMC performance. Refer to the EC Declaration of Conformity (last page). Feature E is standard for new designs.

Single options D1, D2, D5, R are available (as single choice options) on the AUX terminal (10), referenced to V_{o-} .

Option M1 and M2 designate a combination of several options accessible via a D-SUB connector. Option M1 includes the function SD (shutdown).

Note: In double-output models, the options D1, D5, R, and SD concern only output 2.

Single Options Using the AUX Pin

The connection is shown in the figure below. For the description refer to *Adjustment of V_o or V_{o2}* (next section).

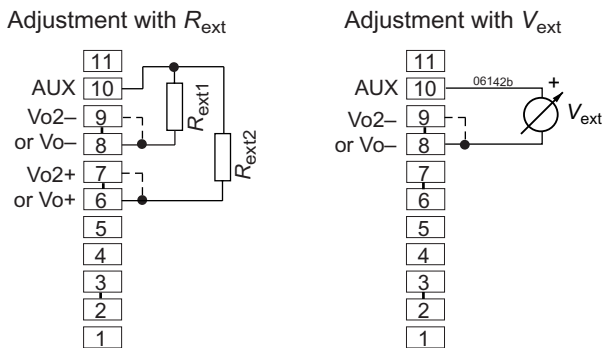

Fig. 20
 Connection of adjust resistors or an external voltage source to adjust the output voltage V_o or V_{o2} (option M1 or M2 not fitted)

Multiple Options M1 or M2 via D-SUB Connector

The option board is suitable for applications, where several options are needed. Option M1 is standard for battery charger models, option M2 is suitable for applications without battery or for simple applications with battery.

Table 15: Pin allocation of the 9 pin D-SUB connector

Pin	Designation	Description
1	GND ¹	System ground / common signal return
2	R	R input ³
3	VCC ²	Positive supply voltage (\approx output 2)
4	D1	Output voltage monitor $V_{o\ low\ D1}$ ³
5	D5	Output 2 voltage monitor $V_{o\ low\ D5}$ ³
6	SD	Shutdown ³
7	D-adj	Adjustment of threshold values of D1 or D5
8	D2	Input voltage monitor $V_{i\ low}$
9	Sys-OK	System okay (all outputs are okay)

- ¹ Do not connect GND1 (pin 1) with the neg. output (-)
- ² Do not connect VCC (pin 3) with the positive output (+)
- ³ In double-output models, R, D1, D5, SD concern output 2 only.

Table 16a: Option board M1

Function	Description
R	Output voltage adjust ¹
D1	Output voltage monitor $V_{o\ low\ D1}$ ¹
D2	Input voltage monitor $V_{i\ low}$
D5	Output 2 voltage monitor ¹ (battery deep discharged): $V_{o\ low\ D5}$
Sys-OK	System okay
SD	Shutdown ¹
D-adj	Adjustment of trigger values D1 and D5

¹ In double-output models, only output 2 is concerned.

Table 16b: Option board M2

Function	Description
R	Output voltage adjust ¹
D2	Input voltage monitor $V_{i\ low}$
D5	Output voltage monitor ¹ (battery deep discharged): $V_{o\ low\ D5}$
D-adjust	Adjustment of trigger values D1 and D5

¹ In double-output models, only output 2 is concerned.

D2: Input Voltage Monitor (Power Fail)

D2 monitors the input voltage V_i . When V_i drops below 65 ± 3 VAC or 92 VDC, the D2 signal output is high impedance (open-collector, max. 50 V).

When V_i is greater than said level, the signal output D2 is conducting: $V_{D2} < 1.5$ V, $I_{D2\ max} < 50$ mA. D1: Output Voltage Monitor

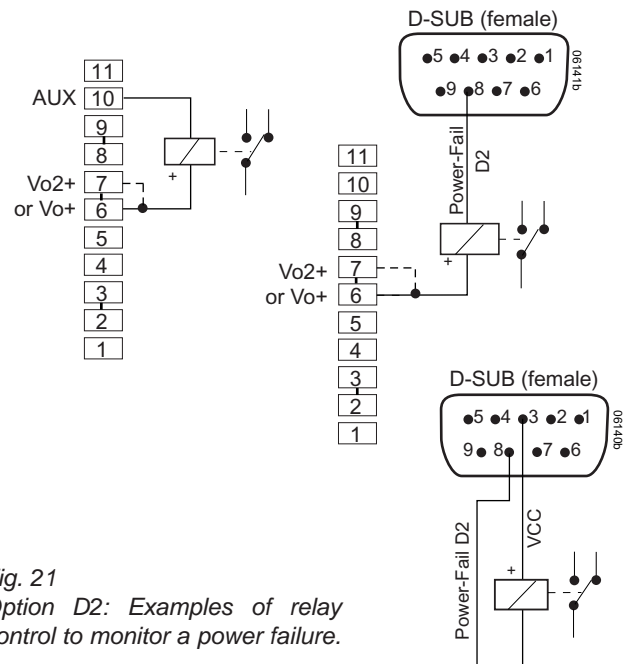

Fig. 21
 Option D2: Examples of relay control to monitor a power failure.

D1: Output Voltage Monitor

D1 is intended for monitoring the bus voltage of a battery-buffered system. It indicates that the system is powered from the battery and can for instance be used as a warning signal or to switch off a part of the load. When the output voltage V_o (or V_{o2}) is greater than $V_{o\ low\ D1}$ specified in table 17, the D1 signal output is conducting: $V_{D1} < 1.5\ V$, $I_{D1\ max} < 50\ mA$.

When V_o is lower, the D1 signal output is high impedance (open-collector, max. 58.6 V). In double-output models, D1 monitors only output 2 (V_{o2}).

In applications without battery-buffering the D1 signal may not be suitable, since smaller dynamic load changes may cause D1 to trigger. For such applications, D5 with a trigger level of approx. 85% of $V_{o\ nom}$ should be chosen (e.g., for a bus voltage of 24.7 V: trigger level at 21 V).

D5: System Voltage Monitor (Battery Low)

D5 monitors the output voltage V_o (V_{o2} in double-output models) or the lowest admissible voltage of a connected battery (battery deep discharge). The definition of D5 is similar to D1, but the trigger level is lower. When V_o (or V_{o2}) is greater than $V_{o\ low\ D5}$ specified in table 17, the D2 signal output is conducting:

$$V_{D5} < 1.5\ V, I_{D5\ max} < 50\ mA.$$

When V_o is lower, the D5 signal output is high impedance (open-collector, max. 58.6 V). In double-output models, D5 monitors only output 2 (V_{o2}).

In systems without battery support, D5 signals that V_o (or V_{o2}) is going to drop below a safe value.

In battery-buffered systems, D5 indicates that the battery has reached its deepest discharge level prior to getting damaged.

The D5 signal can be used for instance to disable loads, save data, or to start a controlled switch-off of running processes.

Table 17: Options D1 and D5: Trigger and switch-on levels

Model	Battery V_{Bat} [V]	$V_{o\ low\ D1}$		$V_{o\ low\ D5}$	
		trigger [V]	switch on [V]	trigger [V]	switch on [V]
LWR/LWN1140	12	11.5	12.1	10.5	12.1
LWR/LWN1240	24	23	24.2	21	24.2
LWR/LWN1840	36	34.4	36.3	31.5	36.3
LWR/LWN1740	48	46	48.4	42	48.4

Adjustment of Threshold Levels (D1/D5)

Pin 7 of the D-SUB connector allows for adjustment of the threshold levels of D1 and D5. Both levels are influenced by the voltage divider R_x / R_y . Resistor R_x to pin 3 (VCC) lowers the levels, whereas R_y to pin 1 (GND1) increases them (see fig. 22).

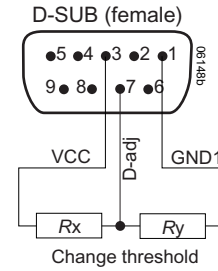

Fig. 22

Wiring to adjust both threshold levels of option D1 or D5

SD: Shutdown

Reduces the output power to approx. 1 W, but the converter is not fully disabled. In a no-load condition, V_o drops below 6.2 V; see fig. 23. In double-output models, only output 2 is influenced.

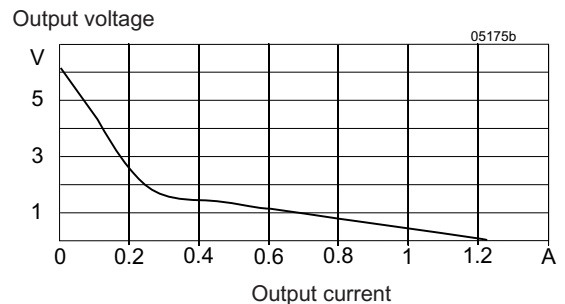

Fig. 23

Output voltage versus output current, while the shutdown is activated ($V_i = V_{i\ nom}$).

Table 18: Shutdown conditions

Voltage V_{SD} on shutdown pin	Result
$< 0.7\ V$	Converter disabled (P_o approx. 1 W)
$\geq 2.0\ V$ or open	Converter enabled

Sys-OK: Status

This function allows in a battery charger application for checking, whether the output is correctly following the external control signal at the R-input (coming for instance from the temperature sensor). The logic is shown in table 19.

Table 19: System OK (M1 with external battery sensor)

System Status	Input	V _{control} sensor signal	V _{Bat} theoretical	V _{Bat} measured	Sys-OK output
System OK	O.K.	2.7 V	27 V	27 V	Low ohmic
Battery overcharged / temp. sensor defect / control voltage to high	O.K.	2.7 V	27 V	28 V	High ohmic
Overload, converter cannot follow the control signal	O.K.	2.7 V	27 V	24 V	High ohmic
Output does not follow control signal, since battery would be overcharged	O.K.	3.0 V	30 V	27 V	High ohmic
System OK	O.K.	2.5 V	25 V	25V	Low ohmic

R: Adjustment of V_o or V_{o2}

The R input allows external adjustment of the output voltage in the range of 50% to 110% V_{o nom}. Double-output models allow only adjustment of output 2 (connected to the terminals 6, 7, 8 and 9). This enables asymmetric output voltage configuration.

Adjustment can be achieved via a resistor or an external voltage source (in the range of 1.25 – 2.75 V).

Note: If the R input is not connected: V_o or V_{o2} = V_{o nom}.

a) Adjustment by an external resistor:

Resistor R_{ext1}, connected between R (pin 2) and GND1 (pin 1) of the D-SUB connector or according to fig. 20.

$$V_o = 50 - 100\% V_{o \text{ nom}} \cdot R_{\text{ext1}} \approx 4 \text{ k}\Omega \cdot \frac{V_o}{V_{o \text{ nom}} - V_o}$$

Resistor R_{ext2}, connected between R (pin 2) and VCC (pin 3) of the D-SUB connector or according to fig. 20.

$$V_o = 100 - 110\% V_{o \text{ nom}} \cdot R_{\text{ext2}} \approx 4 \text{ k}\Omega \cdot \frac{V_o - 2.5 \text{ V}}{2.5 \text{ V} \cdot (V_o / V_{o \text{ nom}} - 1)}$$

Note: If the R function is not included in M1 or M2, refer to figure 20 how to connect R_{ext1} or R_{ext2}.

b) Adjustment by an external control voltage V_{ext} (1.25 – 2.75 V), connected between R (pin 2) and GND (pin 1) of the D-SUB connector or according to fig. 20.

$$V_{\text{ext}} \approx 2.5 \text{ V} \cdot \frac{V_o}{V_{o \text{ nom}}} \quad V_o \approx V_{o \text{ nom}} \cdot \frac{V_{\text{ext}}}{2.5 \text{ V}}$$

Caution: To prevent damage, V_{ext} should not exceed 3 V, nor be negative.

Note: If longer wires are used to connect the R input at the D-SUB connector, the wiring to pin 1 (GND1) should be done as star point connection. If wired differently, the output voltage setting may be adversely affected.

In battery charging systems, an external battery temperature sensor (see *Accessories*) can be connected to optimize V_o. However, adjustment using the R input (pin 2 of D-SUB) is possible as well. The above shown formulas are valid, but V_{o nom} stands for the voltage with open R input (= V_{o safe}).

F: Built-in Second Fuse

A built-in second fuse in the neutral line provides safe phase-

to-phase connection at low mains voltages (e.g., USA 120 V / 208 V / 60 Hz systems).

The built-in second fuse also enables safe connection to the mains, where phase and neutral are not defined or cannot be identified, as e.g., in the case of plug and socket connection to the mains via German Schuko-plugs; see also *Safety and Installation Instructions*.

Option F limits the DC input voltage to ≤ 250 V.

Q: Reverse Polarity Protection

EW models have no bridge rectifier at the input. To provide reverse polarity protection, an additional diode can be fitted. However this lowers the efficiency by approximately 1%.

K2: System Connectors

For installation in systems using pre-assembled harnesses the converters are available with system connectors. They are UL-listed, approved for currents up to 15 A at –40 to 105 °C.

The mating system connectors with screw terminals and retainers are delivered together with every converter with option K2. Use max. 2.5 mm² (AWG 12) solid or stranded wires, or max. 1.5 mm² (AWG 14) stranded wires with crimp termination, stripped length 6 mm. Tightening torque of input/output terminals: max. 0.79 Nm (7 lbs.in.).

G: RoHS

RoHS compliant for all six substances.

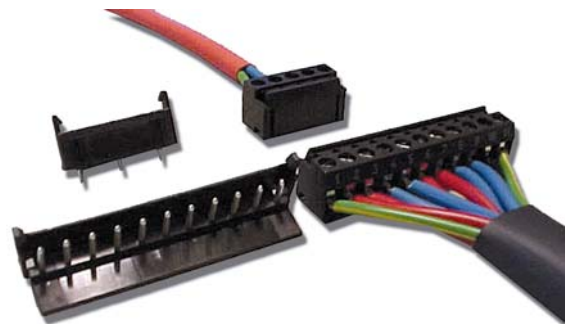

Fig. 24
System connectors Option K2

Accessories

Shock-Resistant Wall Mounting

Set of wall mounting brackets HZZ00618-G (UMB-W)

Content: 2 clamps, 4 countersunk screws M4, washers, and spring washers.

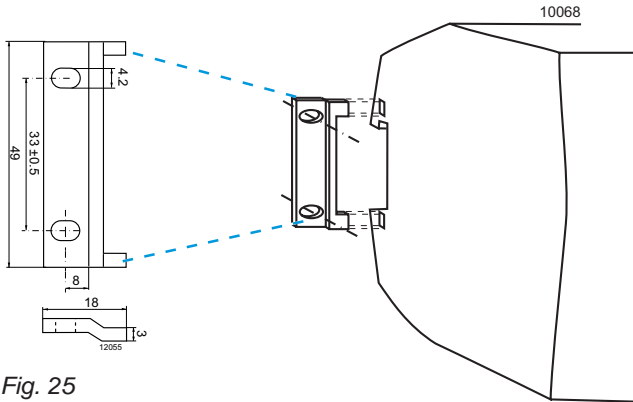

Fig. 25
Wall mounting brackets
HZZ00618-G

Fig. 26
Wall mounting with mounting
brackets HZZ00618-G

Protective Covers over Terminals

Protective covers are available to avoid touching of the terminals. HZZ01219-G and HZZ01219A-G (protective covers with cut-outs) contain in a bag a plastic cover with length $A = 26.5$ mm for the primary terminals and a second one with length $A = 59$ mm for the secondary terminals; see figures below.

Content: 2 covers to protect the input and output terminals.

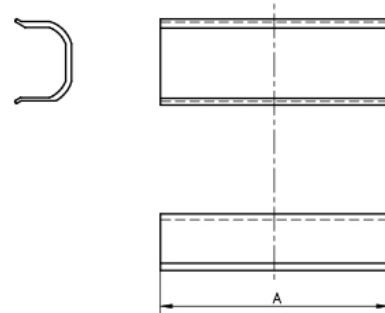

Fig. 28
Protective covers HZZ01219-G

DIN-Rail Fixing Brackets HZZ00624-G

For DIN-Rail vibration-proof fastening, use a set of brackets HZZ00624-G (DMB-EWG). For heavy-duty application 2 sets (= 4 brackets) are preferable.

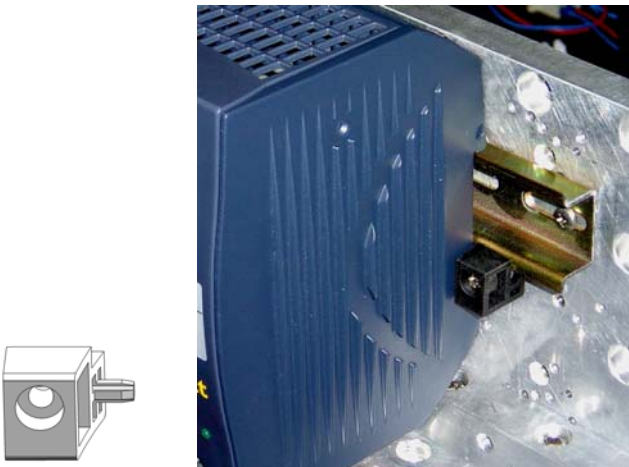

Fig. 27
DIN-rail fixing bracket HZZ00624-G (DMB-EWG)

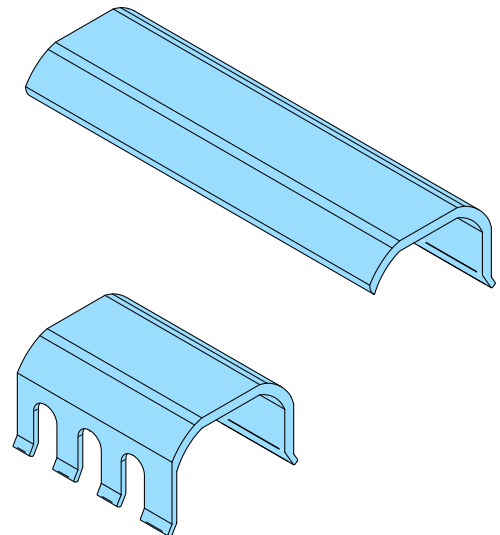

Fig. 28A
Protective covers with cut outs HZZ01219A-G

Battery Temperature Sensor

To charge lead-acid batteries according to their temperature different types of temperature sensors are available, (see *Battery Charging and Temperature Sensor* in this data sheet and the *Temperature Sensor data sheet* at www.power-one.com).

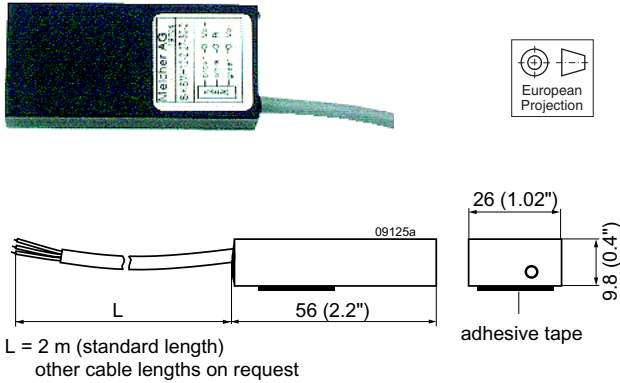

Fig. 29
Temperature sensor

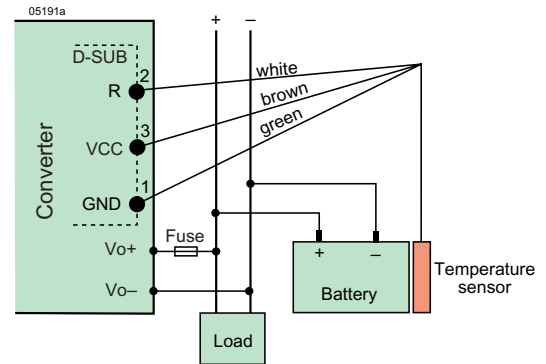

Fig. 30
Connection of temperature sensor

For additional accessory product information, see the accessory data sheets listed with each product series or individual model at our website.

Table 20: Sensors for converters with standard R-input

Battery voltage nom.[V]	Sensor type	Cell voltage [V]	Cell temp. coefficient [mV/K]	Cable length [m]
12	S-KSMH12-2.27-30-2	2.27	-3.0	2
12	S-KSMH12-2.27-35-2	2.27	-3.5	2
24	S-KSMH24-2.27-30-2	2.27	-3.0	2
24	S-KSMH24-2.27-35-2	2.27	-3.5	2
24	S-KSMH24-2.31-35-0	2.31	-3.5	4.5
24	S-KSMH24-2.31-35-2	2.31	-3.5	2
24	S-KSMH24-2.35-35-2	2.35	-3.5	2
48	S-KSMH48-2.27-30-2	2.27	-3.0	2
48	S-KSMH48-2-27-35-2	2.27	-3.5	2

NUCLEAR AND MEDICAL APPLICATIONS - These products are not designed or intended for use as critical components in life support systems, equipment used in hazardous environments, or nuclear control systems.

TECHNICAL REVISIONS - The appearance of products, including safety agency certifications pictured on labels, may change depending on the date manufactured. Specifications are subject to change without notice.

Copyright © 2018, Bel Power Solutions Inc. All rights reserved.

belfuse.com/power-solutions



Компания «ЭлектроПласт» предлагает заключение долгосрочных отношений при поставках импортных электронных компонентов на взаимовыгодных условиях!

Наши преимущества:

- Оперативные поставки широкого спектра электронных компонентов отечественного и импортного производства напрямую от производителей и с крупнейших мировых складов;
- Поставка более 17-ти миллионов наименований электронных компонентов;
- Поставка сложных, дефицитных, либо снятых с производства позиций;
- Оперативные сроки поставки под заказ (от 5 рабочих дней);
- Экспресс доставка в любую точку России;
- Техническая поддержка проекта, помощь в подборе аналогов, поставка прототипов;
- Система менеджмента качества сертифицирована по Международному стандарту ISO 9001;
- Лицензия ФСБ на осуществление работ с использованием сведений, составляющих государственную тайну;
- Поставка специализированных компонентов (Xilinx, Altera, Analog Devices, Intersil, Interpoint, Microsemi, Aeroflex, Peregrine, Syfer, Eurofarad, Texas Instrument, Miteq, Cobham, E2V, MA-COM, Hittite, Mini-Circuits, General Dynamics и др.);

Помимо этого, одним из направлений компании «ЭлектроПласт» является направление «Источники питания». Мы предлагаем Вам помощь Конструкторского отдела:

- Подбор оптимального решения, техническое обоснование при выборе компонента;
- Подбор аналогов;
- Консультации по применению компонента;
- Поставка образцов и прототипов;
- Техническая поддержка проекта;
- Защита от снятия компонента с производства.



Как с нами связаться

Телефон: 8 (812) 309 58 32 (многоканальный)

Факс: 8 (812) 320-02-42

Электронная почта: org@eplast1.ru

Адрес: 198099, г. Санкт-Петербург, ул. Калинина, дом 2, корпус 4, литера А.