

**Circuits from the Lab<sup>®</sup>**  
Reference Designs

Circuits from the Lab<sup>®</sup> reference designs are engineered and tested for quick and easy system integration to help solve today's analog, mixed-signal, and RF design challenges. For more information and/or support, visit [www.analog.com/CN0419](http://www.analog.com/CN0419).

### Devices Connected/Referenced

ADuM4160	Full/Low Speed 5 kV USB Digital Isolator
ADuM5020	Low Emission, Isolated DC-to-DC Converters

## Universal Serial Bus (USB) Peripheral Isolator Circuit

### EVALUATION AND DESIGN SUPPORT

#### Circuit Evaluation Boards

[CN-0419 Circuit Evaluation Board \(EVAL-CN0419-EBZ\)](#)

#### Design and Integration Files

[Schematics, Layout Files, Bill of Materials](#)

### CIRCUIT FUNCTION AND BENEFITS

Universal serial bus (USB) has been established as the standard interface for most computer peripherals. It has mostly displaced RS-232 and the parallel printer port because of superior speed, flexibility, and support of device hot swapping. There has been a strong desire on the part of industrial and medical equipment manufacturers to use the USB standard as well. However, adoption has been slow because there has not been a good way to provide the required isolation for safe and robust connections to machines that control dangerous voltages or low leakage, defibrillation proof connections in medical applications.

[EVAL-CN0419-EBZ](#) galvanically isolates a peripheral device that implements a USB interface and is bus powered with a small isolated dc-to-dc converter based on Analog Devices, Inc., *iCoupler*<sup>®</sup> technology. The application circuit shown in Figure 1 is typically necessary for many medical and industrial applications. This circuit provides the following features:

1. Directly isolates, in the upstream, the USB D+ and D- lines of a cable.
2. Implements an automatic scheme for data flow that does not require external control lines.
3. Provides medical grade isolation.
4. Allow a complete peripheral to meet the USB-IF certification standards.
5. Support full speed (12 Mbps) and low speed (1.5 Mbps) signaling rates.
6. Provides up to 92 mA isolated power for the attached peripheral.

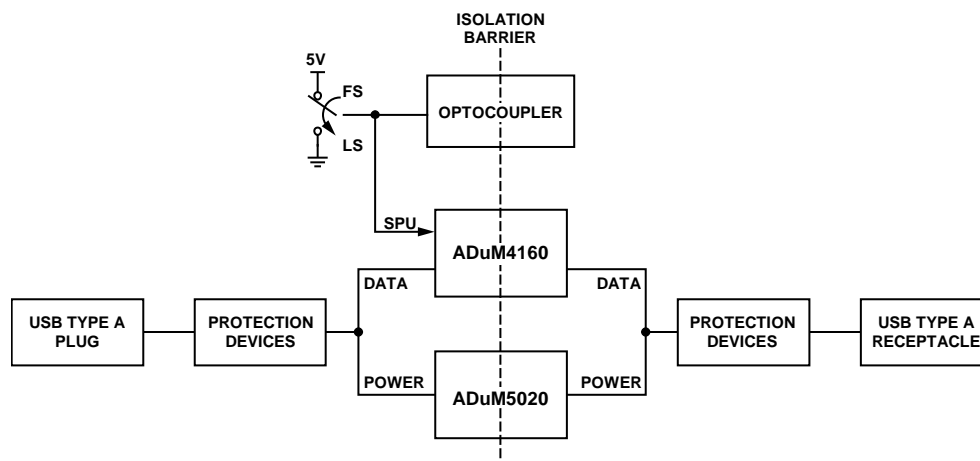

Figure 1. USB Cable Isolator Circuit

#### Rev. 0

Circuits from the Lab<sup>®</sup> reference designs from Analog Devices have been designed and built by Analog Devices engineers. Standard engineering practices have been employed in the design and construction of each circuit, and their function and performance have been tested and verified in a lab environment at room temperature. However, you are solely responsible for testing the circuit and determining its suitability and applicability for your use and application. Accordingly, in no event shall Analog Devices be liable for direct, indirect, special, incidental, consequential or punitive damages due to any cause whatsoever connected to the use of any Circuits from the Lab circuits. (Continued on last page)

## CIRCUIT DESCRIPTION

### USB Isolation

USB is the serial interface of choice for most computer peripherals. Supported by all common commercial operating systems, it enables on-the-fly connection of hardware and loading of drivers. Data transfer modes handle everything from large bulk data transfers for memory devices, to isochronous transfers for streaming media, to interrupt-driven transfers for time critical data such as mouse movements. USB operates at three data transfer rates: low speed (1.5 Mbps), full speed (12 Mbps), and high speed (480 Mbps).

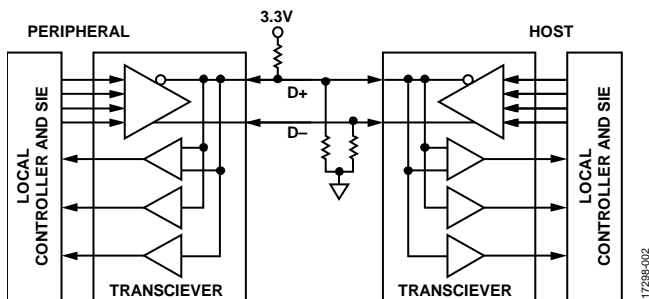

Figure 2. Standard Elements of USB

The USB physical layer consists of only four wires: two provide 5 V power and ground to the peripheral device; the other two, D+ and D-, form a twisted pair that carries differential data with a signaling voltage of 3.3 V. The data is organized into data frames or packets. Each frame can contain bits for clock synchronization, data type identifier, device address, data payload, and an end of packet sequence.

Control of this complex data structure is handled at each end of the cable by a serial interface engine (SIE). This specialized controller—or portion of a larger controller, which usually includes the USB transceiver hardware, takes care of the USB protocol. It handles all flow of control on the bus, enabling and disabling the line drivers and receivers, as required.

The primary challenges in developing a USB isolator are properly determining the direction of data transmission and when to disable drivers to allow an idle bus state. The packet oriented nature of USB data allows a simple method of determining data direction without the overhead of a complete SIE. When the bus is idle, pull-up and pull-down resistors hold the USB in an idle state with no buffers driving the bus.

These challenges have been met with the ADuM4160 USB port isolator, based on Analog Devices iCoupler technology. The ADuM4160 provides mechanisms for detecting the direction of data flow and control over the state of the output buffers. Data direction is determined on a packet by packet basis. By combining high speed CMOS and monolithic air core transformer technology, ADuM4160 provides outstanding performance characteristics and is easily integrated with low and full speed USB-compatible peripheral devices.

### USB Speed Selection

The ADuM4160 has several options for power, bus speed, and electrostatic discharge/electrical overstress (ESD/EOS) protection that must be determined. The ADuM4160 does not support high speed operation and blocks handshaking signals that are used to negotiate that speed. High speed mode starts as a full speed configuration. The peripheral requests high speed support through a process called a high speed chirp. The ADuM4160 ignores the high speed chirp; therefore, the request for high speed operation is never passed to the host, and the peripheral continues to work at full speed.

Because the peripheral operates at a single speed, the isolator is hardwired for the desired speed setting, either full speed or low speed. For the ADuM4160 to operate at full or low speed, the SPU and SPD signals must be configured properly. In this application, a switch at the upstream side allows the user to select between low and full speed. An optocoupler was used to transfer the same pulse signal from the SPU pin on the upstream side to the SPD pin on the downstream side.

To switch between the two modes, flip the actuator of the S1 switch to full speed (FS) mode for full speed operation and to low speed (LS) mode for low speed operation. Figure 3 and Figure 4 show the switch position for each mode of operation.



Figure 3. S1 Switch Position for Full Speed Operation



Figure 4. S1 Switch Position for Low Speed Operation

When the circuit is functioning, packets are detected and data is transferred from one side of the isolation barrier to the other. Data shown in Figure 5 show a typical full speed transaction as time domain data. Features to note in the real-time data are the passive idle state at the start of the packet, which transitions to a driven J state, and then the end of packet at the end of the transaction that shows as a single-ended zero state followed by an idle J state. It is the automatic flow of control and the handling of these special logic states that make the ADuM4160 chip operate.

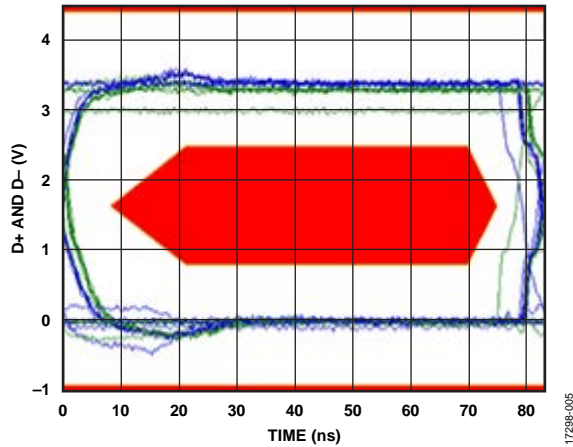

Figure 5. Full Speed Eye Diagram

### Power Isolation

Driving an isolated USB peripheral requires use of an isolated dc-to-dc converter to supply power to the downstream port and cable. To satisfy the requirements of the USB specification, the downstream segment of the cable must provide 5 V power to the peripheral device. An isolated dc-to-dc converter, such as the [ADuM5020](#), can provide this power with enough left over to provide power for downstream devices with low power requirements.

Based on the Analog Devices *iCoupler* technology, the [ADuM5020](#) dc-to-dc converter provides regulated, isolated power that is below CISPR22 Class B limits at full load on a 2-layer printed circuit board (PCB) with ferrites. It implements a split controller architecture with isolated pulse-width modulation (PWM) feedback that transfers power to the secondary side rectified and regulated to 3.3 V or 5.0 V, depending on the setting of the VSEL pin.

The [ADuM5020](#) provides up to 100 mA isolated power. The [ADuM4160](#)  $V_{BUS2}$  pin draws up to 8 mA, leaving 92 mA available for the peripheral.

### Protection Scheme

Common-mode chokes and transient-voltage-suppression (TVS) diodes are placed on the DD+/DD- and UD+/UD- data lines for differential noise and ESD protection respectively. On the [ADuM5020](#), ferrite beads are placed between the  $V_{ISO}$  and  $GND_{ISO}$  pins to reduce the emissions at the 180 MHz primary switching frequency and the 360 MHz secondary side rectifying frequency and harmonics.

The circuit is fully isolated for transients up to 5 kV. It allows common-mode voltages; however, it is not recommended for performing safety related testing, such as high voltage withstand testing. Perform this type of testing on the component level or on a production board.

### COMMON VARIATIONS

For a lower insulation voltage solution, a 2.5 kV version, the [ADuM4160](#) is also available. This family provides isolation for applications like USB peripherals and an isolated USB hub.

### CIRCUIT EVALUATION AND TEST

[CN-0419](#) uses the [EVAL-CN0419-EBZ](#) USB isolator circuit board specifically developed to evaluate and test the circuit in [CN-0419](#). See Figure 1 for a detailed schematic of the circuit.

### Equipment Needed

- PC, Mac, or Linux computer with a USB port
- [EVAL-CN0419-EBZ](#) circuit evaluation board
- Peripheral device such as USB Flash/EE drive, mouse, or keyboard

### System Setup

Figure 6 shows the the test setup.

### Setup

Connect the peripheral to the receptacle edge of the [EVAL-CN0419-EBZ](#). Plug in the device to the USB port of the PC to turn on the device automatically.



Figure 6. Test Setup

**Test**

Set the switch S1 to full speed or low speed operation depending on the peripheral specifications.

For low speed peripherals like a low speed mouse, set the switch to low speed, and D4 illuminates green. For full speed peripherals such as flash drives, set the switch at full speed and D4 illuminates blue.

With the [EVAL-CN0419-EBZ](#) connected to the PC, the connected peripheral should operate normally.

For complete information and details regarding test setup and how to use the software and hardware combined, see the [CN-0419 User Guide](#) available on the analog wiki.



Figure 7. [EVAL-CN0419-EBZ](#) Evaluation Board

**LEARN MORE**

Cantrell, Mark. "Digital Isolator Simplifies USB Isolation in Medical and Industrial Applications," *Analog Dialog*, 2009.

**Data Sheets and Evaluation Boards**

[ADuM4160 data sheet](#)

[ADuM5020 data sheet](#)

**REVISION HISTORY**

3/2019—Revision 0: Initial Version

(Continued from first page) Circuits from the Lab reference designs are intended only for use with Analog Devices products and are the intellectual property of Analog Devices or its licensors. While you may use the Circuits from the Lab reference designs in the design of your product, no other license is granted by implication or otherwise under any patents or other intellectual property by application or use of the Circuits from the Lab reference designs. Information furnished by Analog Devices is believed to be accurate and reliable. However, Circuits from the Lab reference designs are supplied "as is" and without warranties of any kind, express, implied, or statutory including, but not limited to, any implied warranty of merchantability, noninfringement or fitness for a particular purpose and no responsibility is assumed by Analog Devices for their use, nor for any infringements of patents or other rights of third parties that may result from their use. Analog Devices reserves the right to change any Circuits from the Lab reference designs at any time without notice but is under no obligation to do so.

©2019 Analog Devices, Inc. All rights reserved. Trademarks and registered trademarks are the property of their respective owners.  
CN17298-0-3/19(0)





Компания «ЭлектроПласт» предлагает заключение долгосрочных отношений при поставках импортных электронных компонентов на взаимовыгодных условиях!

Наши преимущества:

- Оперативные поставки широкого спектра электронных компонентов отечественного и импортного производства напрямую от производителей и с крупнейших мировых складов;
- Поставка более 17-ти миллионов наименований электронных компонентов;
- Поставка сложных, дефицитных, либо снятых с производства позиций;
- Оперативные сроки поставки под заказ (от 5 рабочих дней);
- Экспресс доставка в любую точку России;
- Техническая поддержка проекта, помощь в подборе аналогов, поставка прототипов;
- Система менеджмента качества сертифицирована по Международному стандарту ISO 9001;
- Лицензия ФСБ на осуществление работ с использованием сведений, составляющих государственную тайну;
- Поставка специализированных компонентов (Xilinx, Altera, Analog Devices, Intersil, Interpoint, Microsemi, Aeroflex, Peregrine, Syfer, Eurofarad, Texas Instrument, Miteq, Cobham, E2V, MA-COM, Hittite, Mini-Circuits, General Dynamics и др.);

Помимо этого, одним из направлений компании «ЭлектроПласт» является направление «Источники питания». Мы предлагаем Вам помощь Конструкторского отдела:

- Подбор оптимального решения, техническое обоснование при выборе компонента;
- Подбор аналогов;
- Консультации по применению компонента;
- Поставка образцов и прототипов;
- Техническая поддержка проекта;
- Защита от снятия компонента с производства.



#### Как с нами связаться

**Телефон:** 8 (812) 309 58 32 (многоканальный)

**Факс:** 8 (812) 320-02-42

**Электронная почта:** [org@eplast1.ru](mailto:org@eplast1.ru)

**Адрес:** 198099, г. Санкт-Петербург, ул. Калинина, дом 2, корпус 4, литера А.