

THIS DRAWING IS UNPUBLISHED. RELEASED FOR PUBLICATION
 © COPYRIGHT - A1 ALL RIGHTS RESERVED.

LOC	DIST	REVISIONS					
FT	0	P	LTR	DESCRIPTION	DATE	DWN	APVD
			A2	HIGH TEMP PHRASE REMOVED	05MAY2016	FP	NG

- 1 ALL DIMENSIONS ARE IN MM.
- 2 BUCHANAN LOGO TO APPEAR ON HOUSING LOCATION OPTIONAL WHERE SPACE PERMITS.
- △3 NON CUMULATIVE
- △4 PARTS TO BE MARKED WITH PERMANENT BLACK MARKING.
- △5 POSITIONS 1-2, 3-4, AND 7-8 COMMONED. POSITIONS 9-10 NOT LOADED.
- △6 POSITIONS 1-2, 7-8, AND 9-10 COMMONED.

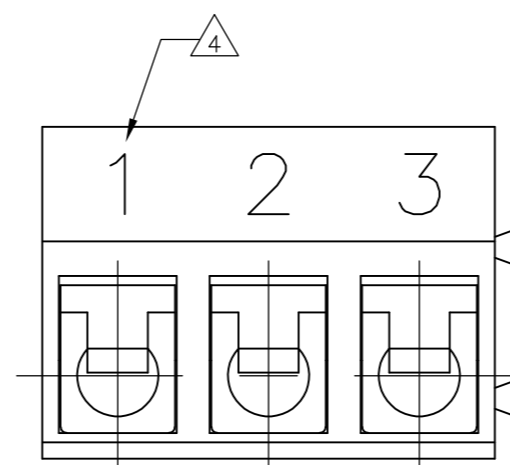
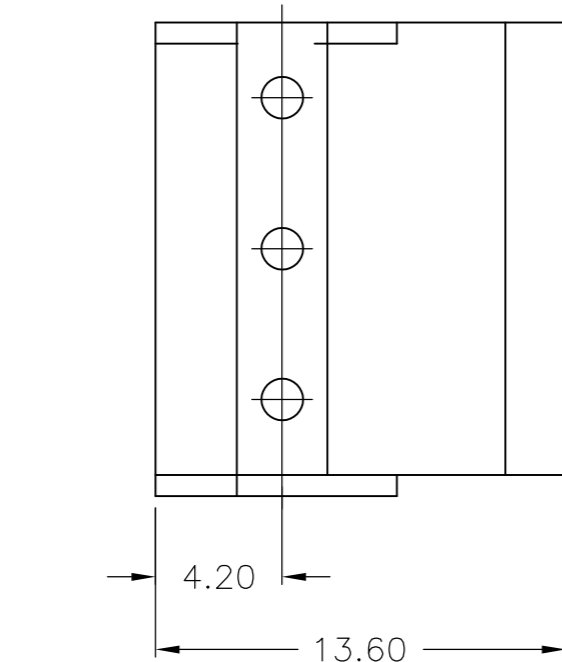
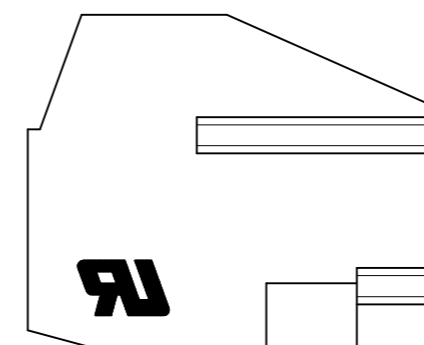
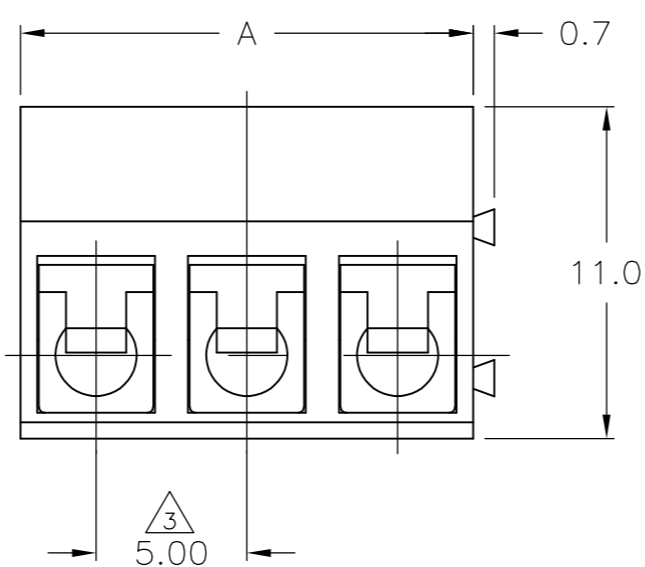
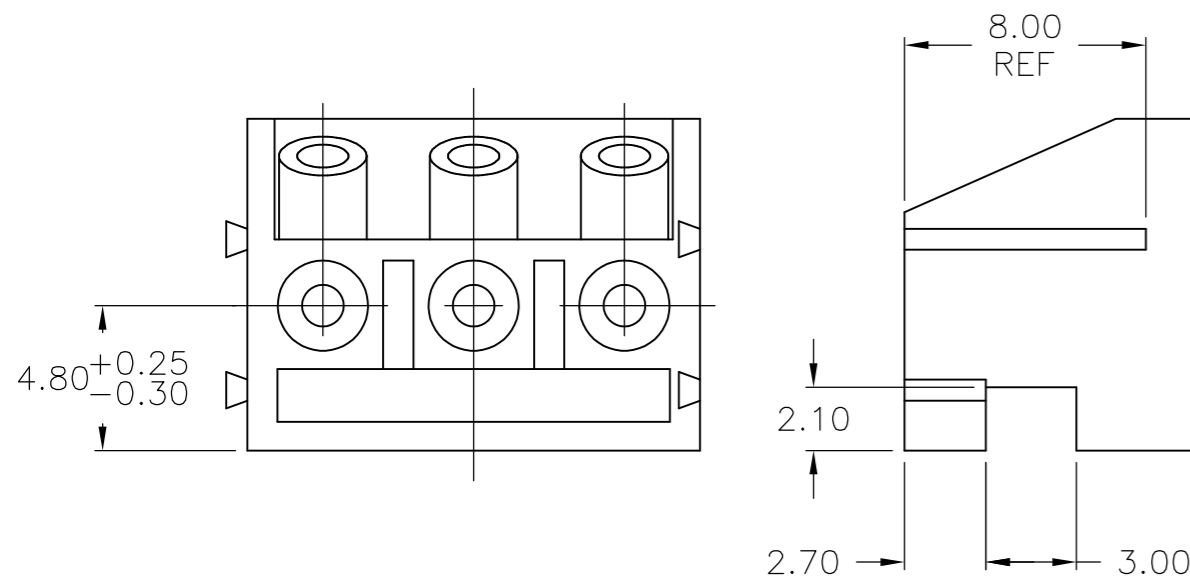
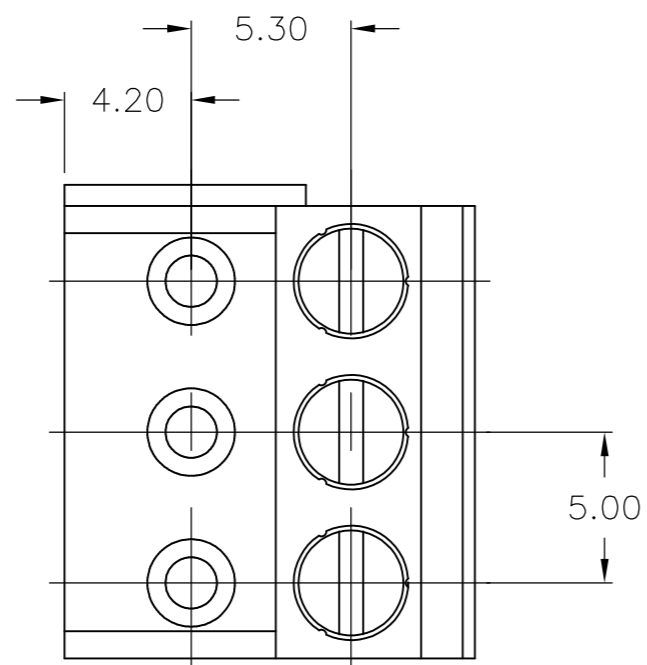

DETAIL C

△	DESCRIPTION	FINISH	QTY	NO	DATE	REV
△6	OBSOLETE	DETAIL F	TIN	50.00	10	5-1776263-2
△5	OBSOLETE	DETAIL E	TIN	50.00	10	5-1776263-1
	OBSOLETE	DETAIL D	TIN	45.00	9	5-1776263-0
	OBSOLETE		0.254um GOLD	10.00	2	4-1776263-9
	OBSOLETE	DETAIL C	TIN	15.00	3	4-1776263-8
	OBSOLETE		GOLD FLASH	35.00	7	4-1776263-7
	OBSOLETE		GOLD FLASH	30.00	6	4-1776263-6
	OBSOLETE		GOLD FLASH	15.00	3	4-1776263-3
	OBSOLETE		0.381um GOLD	35.00	7	3-1776263-7
	OBSOLETE		0.381um GOLD	30.00	6	3-1776263-6
	OBSOLETE		0.381um GOLD	15.00	3	3-1776263-3
	OBSOLETE		TIN	120.00	24	2-1776263-4
	OBSOLETE		TIN	115.00	23	2-1776263-3
	OBSOLETE		TIN	110.00	22	2-1776263-2
	OBSOLETE		TIN	105.00	21	2-1776263-1
	OBSOLETE		TIN	100.00	20	2-1776263-0
	OBSOLETE		TIN	95.00	19	1-1776263-9
	OBSOLETE		TIN	90.00	18	1-1776263-8
	OBSOLETE		TIN	85.00	17	1-1776263-7
	OBSOLETE		TIN	80.00	16	1-1776263-6
	OBSOLETE		TIN	75.00	15	1-1776263-5
	OBSOLETE		TIN	70.00	14	1-1776263-4
	OBSOLETE		TIN	65.00	13	1-1776263-3
			TIN	60.00±0.40	12	1-1776263-2
			TIN	55.00±0.40	11	1-1776263-1
			TIN	50.00±0.35	10	1-1776263-0
			TIN	45.00±0.30	9	1776263-9
			TIN	40.00±0.30	8	1776263-8
			TIN	35.00±0.25	7	1776263-7
			TIN	30.00±0.25	6	1776263-6
			TIN	25.00±0.25	5	1776263-5
			TIN	20.00±0.25	4	1776263-4
			TIN	15.00±0.25	3	1776263-3
			TIN	10.00±0.25	2	1776263-2
DETAIL	FINISH	DIM A	NO OF POS	PART NUMBER		

THIS DRAWING IS A CONTROLLED DOCUMENT.

DWN	S SCHLEGEL	5/6/05	 TE Connectivity
CHK	C RICHARD	5/6/05	
APVD	C RICHARD	5/6/05	
NAME	C RICHARD		
PRODUCT SPEC	-		TERMINAL BLOCK, 90 DEGREE, STACKING W/ WIRE PROTECTION, 5.0mm PITCH
APPLICATION SPEC	-		SIZE CAGE CODE DRAWING NO RESTRICTED TO
WEIGHT	A2	00779	C=1776263
CUSTOMER DRAWING	SCALE	6:1	SHEET 1 of 2 REV A2

THIS DRAWING IS UNPUBLISHED. RELEASED FOR PUBLICATION
 © COPYRIGHT - By - ALL RIGHTS RESERVED.

LOC		DIST		REVISIONS			
P	LTR	DESCRIPTION		DATE	DWN	APVD	
-	-	SEE SHEET 1		-	-	-	

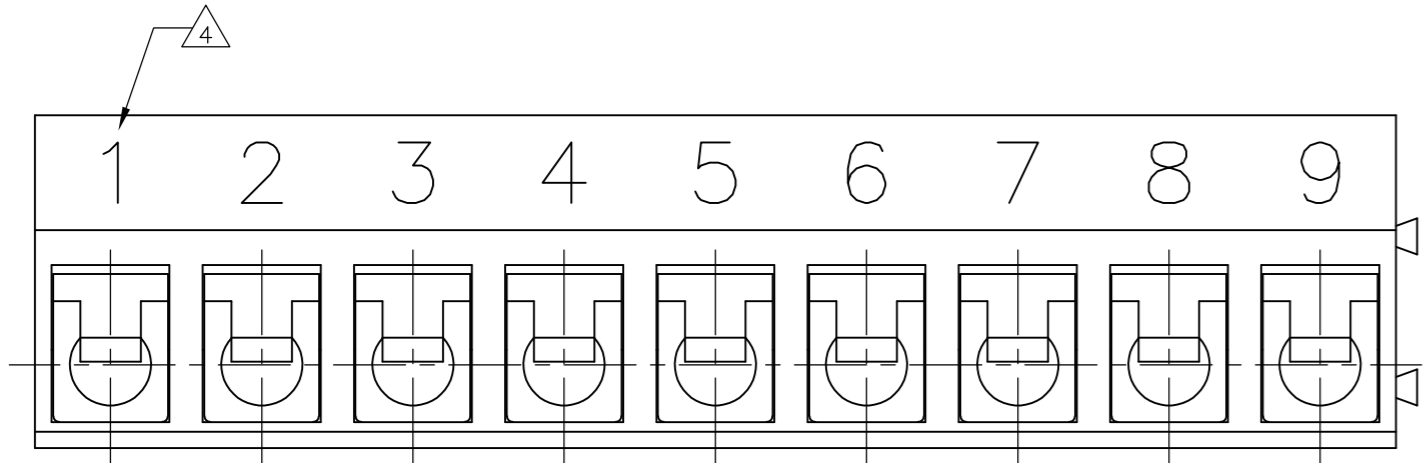

DETAIL D

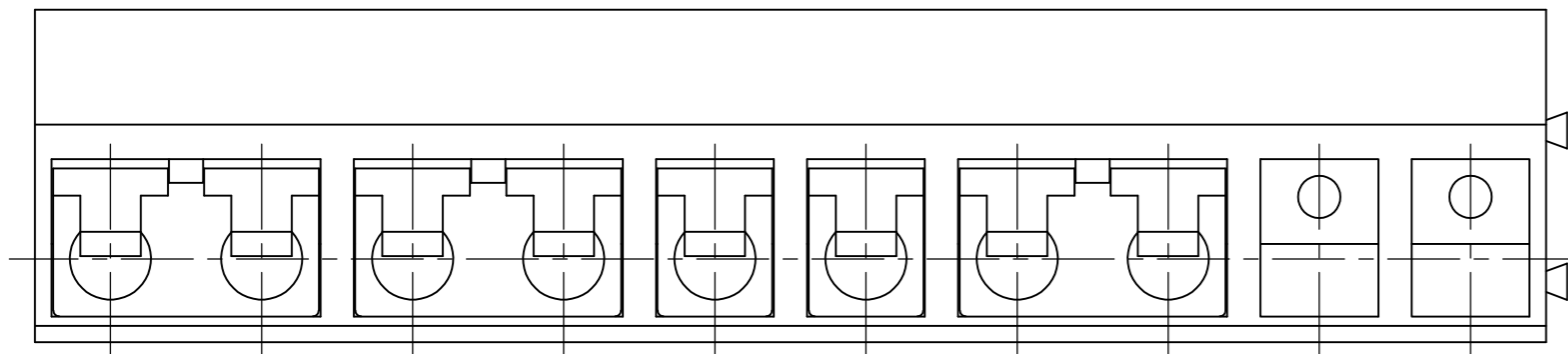

DETAIL E

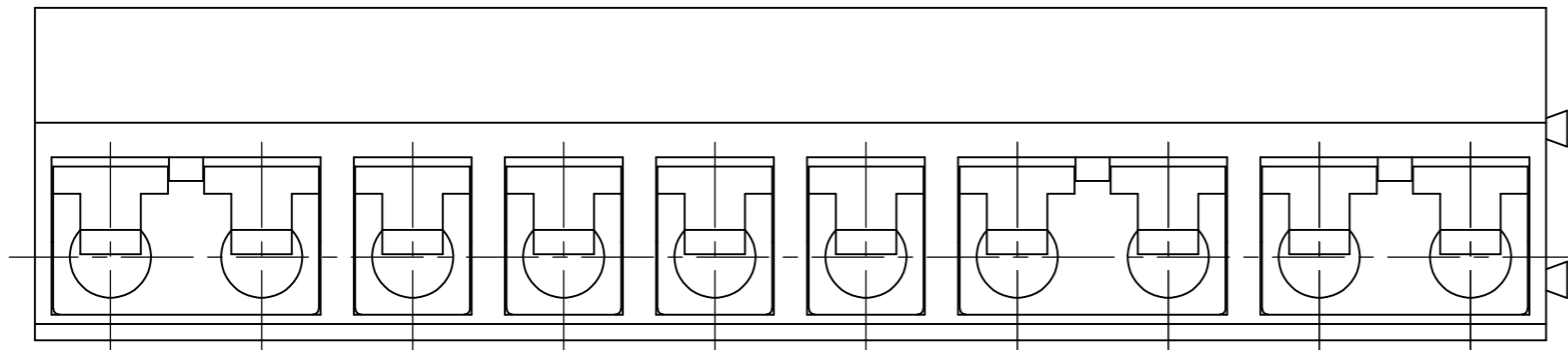

DETAIL F

1. Application and Features:

- 1-1. This terminal block is designed to plug onto loose pins or pin header strips.
- 1-2. With wire guard for wire protection so that the screw doesn't press directly on the wire.
- 1-3. Easy handling due to the pluggable system horizontally or vertically.

2. Technical Data:

- 2-1. Material(blue)
- 2-1-1. Housing: PA 66
- 2-1-2. Metal Housing: Brass
Finish: see table.
- 2-1-3. Wire Guard: Phosphor Bronze
- 2-1-4. Screw: Steel galvanized and chromated, M2.6.

2-3. Electrical:

- 2-3-1. Current rating: 10 amps/way max.
- 2-3-2. Contact resistance: 20mohm (MAX).
- 2-3-3. Insulation resistance: 2000Mohm /500V.
- 2-3-4. Withstanding voltage: 1500 VAC/min, test time= 60sec/1pc.
- 2-3-5. Operation voltage: 300 VAC.
- 2-3-6. Wire Range: 16-24 AWG.

2.4 Mechanical:

- 2-4-1. Torque: 3 in-lb.
- 2-4-2. Contact retention Force: 0.2Kg/cm (min).
- 2-4-3. Operating temperature: -40°C to +105°C.
- 2-4-4. Solderability: 95% coverage (min).
test temperature=230°C±10°C
test time= 3sec±0.5sec.

1776263

THIS DRAWING IS A CONTROLLED DOCUMENT.		DWN	S SCHLEGEL	5/6/05		TE Connectivity																				
DIMENSIONS: mm		CHK	C RICHARD	5/6/05		NAME																				
TOLERANCES UNLESS OTHERWISE SPECIFIED:		APVD	C RICHARD	5/6/05		TERMINAL BLOCK, 90 DEGREE, STACKING W/ WIRE PROTECTION, 5.0mm PITCH																				
<table border="0"> <tr><td>0 PLC</td><td>±</td><td>-</td></tr> <tr><td>1 PLC</td><td>±</td><td>0.3</td></tr> <tr><td>2 PLC</td><td>±</td><td>0.25</td></tr> <tr><td>3 PLC</td><td>±</td><td>-</td></tr> <tr><td>4 PLC</td><td>±</td><td>-</td></tr> <tr><td>ANGLES</td><td>±</td><td>-</td></tr> </table>		0 PLC	±	-		1 PLC	±	0.3	2 PLC	±	0.25	3 PLC	±	-	4 PLC	±	-	ANGLES	±	-	PRODUCT SPEC			SIZE	CAGE CODE	DRAWING NO
0 PLC	±	-																								
1 PLC	±	0.3																								
2 PLC	±	0.25																								
3 PLC	±	-																								
4 PLC	±	-																								
ANGLES	±	-																								
MATERIAL	FINISH	WEIGHT	-		A2	00779	C=1776263	-																		
CUSTOMER DRAWING					SCALE	6:1	SHEET	2 OF 2	REV	A2																



Компания «ЭлектроПласт» предлагает заключение долгосрочных отношений при поставках импортных электронных компонентов на взаимовыгодных условиях!

Наши преимущества:

- Оперативные поставки широкого спектра электронных компонентов отечественного и импортного производства напрямую от производителей и с крупнейших мировых складов;
- Поставка более 17-ти миллионов наименований электронных компонентов;
- Поставка сложных, дефицитных, либо снятых с производства позиций;
- Оперативные сроки поставки под заказ (от 5 рабочих дней);
- Экспресс доставка в любую точку России;
- Техническая поддержка проекта, помощь в подборе аналогов, поставка прототипов;
- Система менеджмента качества сертифицирована по Международному стандарту ISO 9001;
- Лицензия ФСБ на осуществление работ с использованием сведений, составляющих государственную тайну;
- Поставка специализированных компонентов (Xilinx, Altera, Analog Devices, Intersil, Interpoint, Microsemi, Aeroflex, Peregrine, Syfer, Eurofarad, Texas Instrument, Miteq, Cobham, E2V, MA-COM, Hittite, Mini-Circuits, General Dynamics и др.);

Помимо этого, одним из направлений компании «ЭлектроПласт» является направление «Источники питания». Мы предлагаем Вам помощь Конструкторского отдела:

- Подбор оптимального решения, техническое обоснование при выборе компонента;
- Подбор аналогов;
- Консультации по применению компонента;
- Поставка образцов и прототипов;
- Техническая поддержка проекта;
- Защита от снятия компонента с производства.



Как с нами связаться

Телефон: 8 (812) 309 58 32 (многоканальный)

Факс: 8 (812) 320-02-42

Электронная почта: org@eplast1.ru

Адрес: 198099, г. Санкт-Петербург, ул. Калинина, дом 2, корпус 4, литера А.