

.318 [8.08] FOOTPRINT
(STANDARD PCB LAYOUT)

REVISIONS			
REV	ECN, ERN NO.	DATE	APPRD.
A	PRODUCT DRAWING (EAR 12932)	APR17/06	K.L.



DIMENSIONS

SIZE	A±.015 [0.38]	B±.005 [0.13]	C±.005 [0.13]	D BSC.
009	1.213 [30.81]	.666 [16.92]	.984 [24.99]	.432 [10.97]
015	1.541 [39.14]	.994 [25.25]	1.312 [33.32]	.756 [19.20]
025	2.088 [53.04]	1.534 [38.96]	1.852 [47.04]	1.304 [33.12]
037	2.729 [69.32]	2.182 [55.42]	2.500 [63.50]	1.956 [49.68]

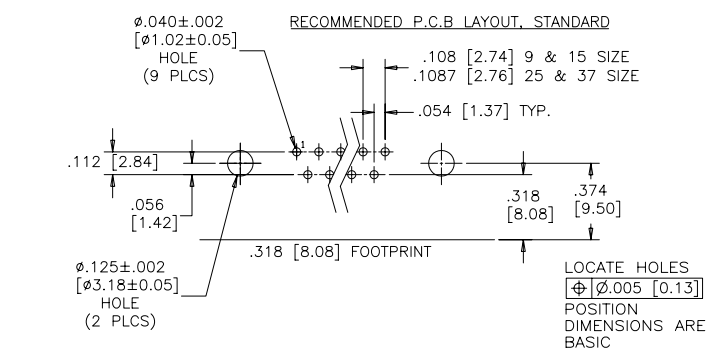
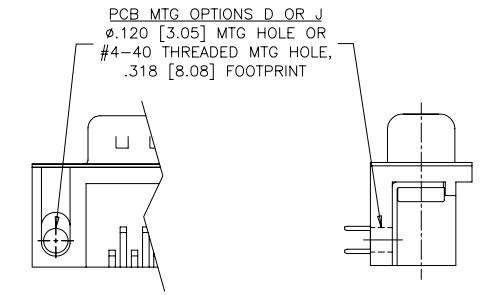
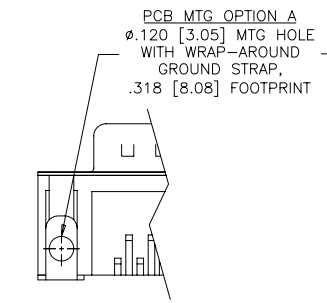
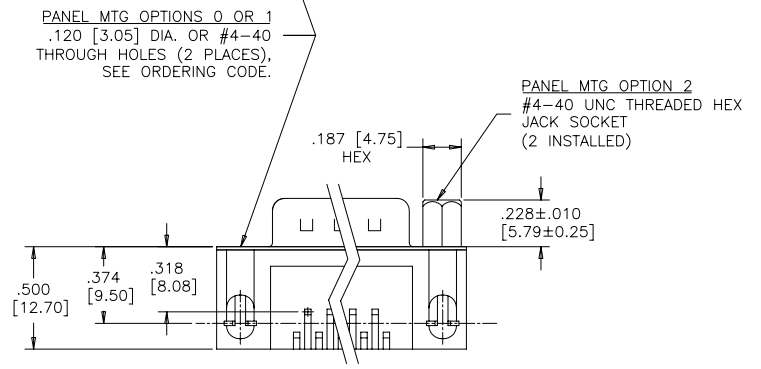

ORDERING CODE:

PART NUMBER: 6 E 1 7 X - X X X P X X - X 2 1 X

SERIES _____

PCB MTG. OPTIONS

A=Ø.120 [3.05] MTG HOLE WITH WRAP-AROUND GROUND STRAP, .318 [8.08] FOOTPRINT
 C=BOARDLOCK OPTION, .318 [8.08] FOOTPRINT
 D=Ø.120 [3.05] MTG HOLE, .318 [8.08] FOOTPRINT
 J=#4-40 THREADED MTG HOLE, .318 [8.08] FOOTPRINT
 U=Ø.120 [3.05] MTG HOLE, .590 [14.99] FOOTPRINT
 Y=BOARDLOCK OPTION, .590 [14.99] FOOTPRINT

NUMBER OF CONTACTS
009, 015, 025, 037

STYLE
P=PIN

PCB LAYOUT CODE
NO DIGIT=STANDARD MOUNTING HOLE POSITION
.374 [9.50] DIM'N FOR .318 [8.08] F/P
.315 [8.00] DIM'N FOR .590 [14.99] F/P
E=.646 [16.41] DIM'N FOR .590 [14.99] F/P

SHELL CHARACTERISTICS
21=TIN PLATED PLUG SHELL WITH GROUNDING INDENTS

PANEL MOUNTING OPTIONS
0=Ø.120" [3.05] THROUGH HOLE
1=#4-40 THREADED HOLE
2=MOUNTING OPTION 1 WITH #4-40 UNC HEX JACK SOCKETS INSTALLED

CONTACT PLATING OPTIONS
BF=ENGAGEMENT AREA 3µ" [0.08 MICRONS] GOLD FLASH
CF=ENGAGEMENT AREA 15µ" [0.38 MICRONS] GOLD
AJ=ENGAGEMENT AREA 30µ" [0.76 MICRONS] GOLD

SEE SHEET 2 FOR NOTES & SPECIFICATIONS

DRAWN	A.CHENG	DATE	APR17/06
DESIGNED			
CHECKED	K.LAMBIE	DATE	APR17/06
I. E. APPRD.			
Q. A. APPRD.			
DWG. APPRD.			
ENG. REL. NO.		DWG	DRAWING NO.
REF.	EAR 12932	C	P-6E17X-XXXPXX-X21X
DIMENSIONS ARE IN INCHES		CODE ID. NO.	03554

Amphenol Canada Corp.			
TITLE			
6E17 SERIES D-SUB CONNECTOR, 9 TO 37 SIZE PIN, RIGHT ANGLE WITH F/P, MTG AND PLATING OPTIONS, RoHS COMPLIANT			
REV.	A	SCALE	2/1
		WT.	-----
		SURF.	-----
		SHEET 1 OF 2	

THIS DOCUMENT CONTAINS PROPRIETARY INFORMATION AND SUCH INFORMATION MAY NOT BE DISCLOSED TO OTHERS FOR ANY PURPOSE OR USED FOR MANUFACTURING PURPOSES WITHOUT WRITTEN PERMISSION FROM AMPHENOL CANADA CORP.

.590 [14.99] FOOTPRINT
(STANDARD PCB LAYOUT)

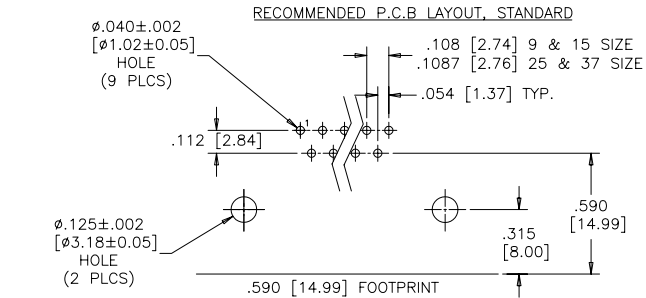

DIMENSIONS

SIZE	A±.015 [0.38]	B±.005 [0.13]	C±.005 [0.13]	D BSC.
009	1.213 [30.81]	.666 [16.92]	.984 [24.99]	.432 [10.97]
015	1.541 [39.14]	.994 [25.25]	1.312 [33.32]	.756 [19.20]
025	2.088 [53.04]	1.534 [38.96]	1.852 [47.04]	1.304 [33.12]
037	2.729 [69.32]	2.182 [55.42]	2.500 [63.50]	1.956 [49.68]

SPECIFICATIONS:

MATERIALS: ALL MATERIALS ARE RoHS COMPLIANT

SHELL: STEEL, TIN PLATED

INSERTS: HIGH TEMPERATURE RESISTANT NYLON, GLASS REINFORCED, UL FLAMMABILITY RATING 94V-0, COLOUR: BLACK

CONTACTS: COPPER ALLOY, GOLD PLATING (SEE ORDERING CODE) OVER 50u" [1.27 MICRONS] NICKEL ON ENGAGEMENT AREA WITH 100u" [2.54 MICRONS] MIN. MATTE TIN ON CONTACT TERMINALS.

BOARDLOCK: COPPER ALLOY, TIN PLATED

ELECTRICAL DATA:

CURRENT RATING: 5 AMP

CONTACT RESISTANCE: 15 MILLIOHMS MAX.

INSULATION RESISTANCE: 3000 MEGOHMS MIN.

DIELECTRIC WITHSTANDING VOLTAGE: 1000 VAC rms

OPERATING TEMPERATURE: -55°C TO +105°C

.590 [14.99] FOOTPRINT
(PCB LAYOUT CODE E)

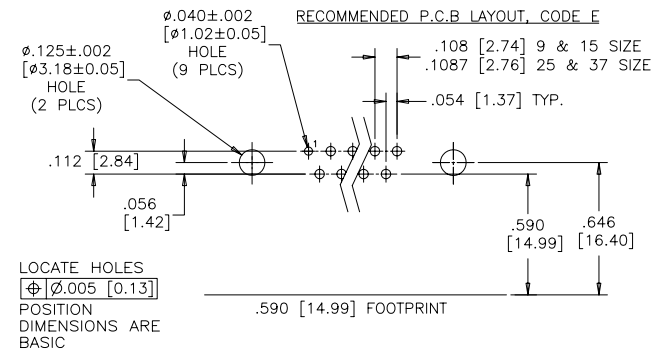
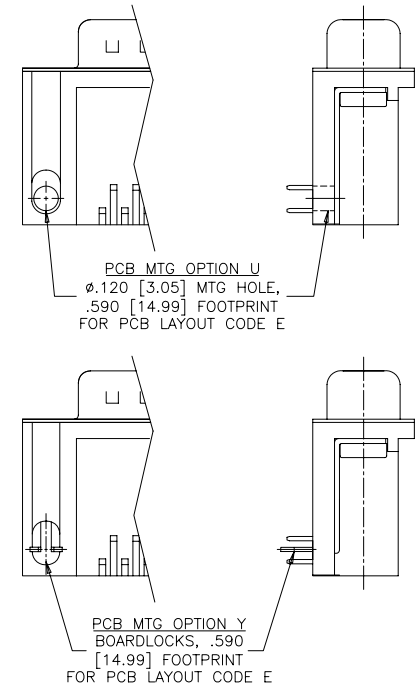

SEE SHEET 1 FOR ORDERING CODE

DRAWN	A.CHENG	DATE	APR17/06
DESIGNED			
CHECKED	K.LAMBIE	APR17/06	
I. E. APPRD.			
Q. A. APPRD.			
DWG. APPRD.			
ENG. REL. NO.			
REF.	EAR 12932		
DIMENSIONS ARE IN INCHES		CODE ID. NO.	03554

Amphenol Canada Corp.

TITLE
6E17 SERIES D-SUB CONNECTOR, 9 TO 37 SIZE PIN, RIGHT ANGLE WITH F/P, MTG AND PLATING OPTIONS, RoHS COMPLIANT

DWG	DRAWING NO.	REV.
C	P-6E17X-XXXPXX-X21X	A
SCALE	2/1	WT. -----
SURF.	-----	SHEET 2 OF 2



Компания «ЭлектроПласт» предлагает заключение долгосрочных отношений при поставках импортных электронных компонентов на взаимовыгодных условиях!

Наши преимущества:

- Оперативные поставки широкого спектра электронных компонентов отечественного и импортного производства напрямую от производителей и с крупнейших мировых складов;
- Поставка более 17-ти миллионов наименований электронных компонентов;
- Поставка сложных, дефицитных, либо снятых с производства позиций;
- Оперативные сроки поставки под заказ (от 5 рабочих дней);
- Экспресс доставка в любую точку России;
- Техническая поддержка проекта, помощь в подборе аналогов, поставка прототипов;
- Система менеджмента качества сертифицирована по Международному стандарту ISO 9001;
- Лицензия ФСБ на осуществление работ с использованием сведений, составляющих государственную тайну;
- Поставка специализированных компонентов (Xilinx, Altera, Analog Devices, Intersil, Interpoint, Microsemi, Aeroflex, Peregrine, Syfer, Eurofarad, Texas Instrument, Miteq, Cobham, E2V, MA-COM, Hittite, Mini-Circuits, General Dynamics и др.);

Помимо этого, одним из направлений компании «ЭлектроПласт» является направление «Источники питания». Мы предлагаем Вам помощь Конструкторского отдела:

- Подбор оптимального решения, техническое обоснование при выборе компонента;
- Подбор аналогов;
- Консультации по применению компонента;
- Поставка образцов и прототипов;
- Техническая поддержка проекта;
- Защита от снятия компонента с производства.



Как с нами связаться

Телефон: 8 (812) 309 58 32 (многоканальный)

Факс: 8 (812) 320-02-42

Электронная почта: org@eplast1.ru

Адрес: 198099, г. Санкт-Петербург, ул. Калинина, дом 2, корпус 4, литера А.