

High Current Charge Pump DC-to-DC Converter

Features:

- Pin Compatible With TC7662/ICL7662/SI7661
- High Output Current 80 mA
- No External Diodes Required
- Wide Operating Range 3V to 18V
- Low Output Impedance 28Ω Typ.
- No Low Voltage Terminal Required
- Application Zener On-Chip
- OSC Frequency Doubling Pin Option for Smaller Output Capacitors

Applications:

- Laptop Computers
- Disk Drives
- Process Instrumentation
- μP-Based Controllers

Device Selection Table

Part Number	Package	Operating Temp. Range
TC962COE	16-Pin SOIC Wide	0°C to +70°C
TC962CPA	8-Pin Plastic DIP	0°C to +70°C
TC962EPA	8-Pin Plastic DIP	-40°C to +85°C
TC962IJA	8-Pin Cerdip	-25°C to +85°C
TC962MJA	8-Pin Cerdip	-55°C to +125°C

General Description:

The TC962 is an advanced version of the industry standard TC7662 high voltage DC-to-DC converter. Using improved design techniques and CMOS construction, the TC962 can source as much as 80 mA versus the 7662's 20 mA capability.

As an inverter, the TC962 can put out voltages as high as 18V and as low as 3V without the need for external diodes. The output impedance of the device is a low 28Ω (with the proper capacitors), voltage conversion efficiency is 99.9%, and power conversion efficiency is 97%.

The low voltage terminal (pin 6) required in some TC7662 applications has been eliminated. Grounding this terminal will double the oscillator frequency from 12 kHz to 24 kHz. This will allow the use of smaller capacitors for the same output current and ripple, in most applications. Only two external capacitors are required for inverter applications. In the event an external clock is needed to drive the TC962 (such as paralleling), driving this pin directly will cause the internal oscillator to sync to the external clock.

Pin 1, which is used as a test pin on the 7662, is a voltage reference Zener on the TC962. This Zener (6.4V at 5 mA) has a dynamic impedance of 12Ω and is intended for use where the TC962 is supplying current to external regulator circuitry and a reference is needed for the regulator circuit. (See **Section 3.0 "Applications Information" Applications Information**).

The TC962 is compatible with the LTC1044, SI7661 and ICL7662. It should be used in designs that require greater power and/or less input to output voltage drop. It offers superior performance over the ICL7660S.

Package Type

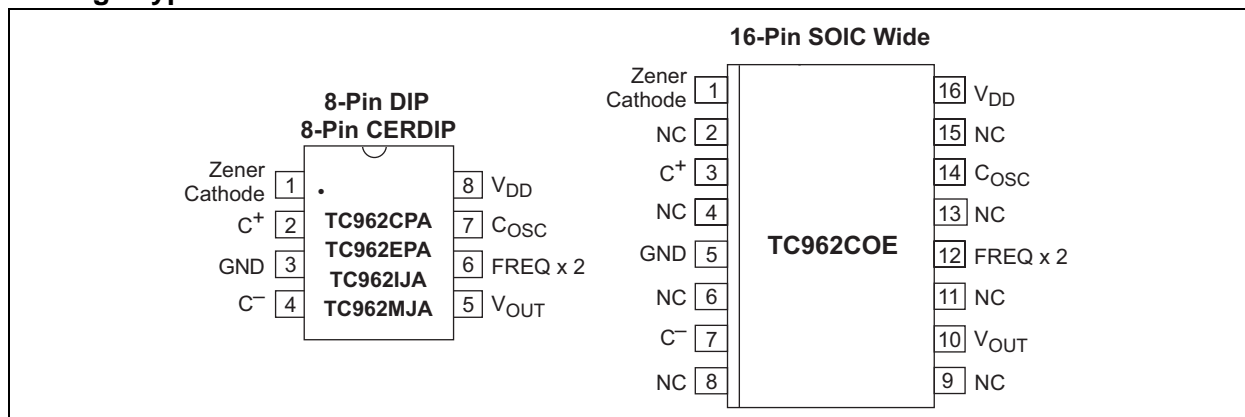

1.0 ELECTRICAL CHARACTERISTICS

Absolute Maximum Ratings*

Supply Voltage (V_{DD} to GND)	+18V
Input Voltage Any Pin	($V_{DD} + 0.3$) to ($V_{SS} - 0.3$) (Note 1)
Current Into Any Pin.....	10 mA
ESD Protection	$\pm 2000V$
Output Short Circuit	Continuous (at 5.5V Input)
Package Power Dissipation ($T_A \leq 70^\circ C$)	
SOIC	760 mW
PDIP	730 mW
CERDIP	800 mW
Package Thermal Resistance	
CERDIP, $R_{\theta_{J-A}}$	$90^\circ C/W$
PDIP, $R_{\theta_{J-A}}$	$140^\circ C/W$
Operating Temperature Range	
CPA, COE	$0^\circ C$ to $+70^\circ C$
IJA	$-25^\circ C$ to $+85^\circ C$
EPA	$-40^\circ C$ to $+85^\circ C$
MJA	$-55^\circ C$ to $+125^\circ C$
Storage Temperature Range	$-65^\circ C$ to $+150^\circ C$

*Stresses above those listed under "Absolute Maximum Ratings" may cause permanent damage to the device. These are stress ratings only and functional operation of the device at these or any other conditions above those indicated in the operation sections of the specifications is not implied. Exposure to Absolute Maximum Rating conditions for extended periods may affect device reliability.

TC962 ELECTRICAL SPECIFICATIONS

Electrical Characteristics: $V_{DD} = 15V$, $T_A = 25^\circ C$ (See Figure) unless otherwise noted.						
Symbol	Parameter	Min	Typ	Max	Units	Test Conditions
V_{DD}	Supply Voltage	3	—	18	V	
I_S	Supply Current	—	—	—	μA	$R_L = \infty$
	$V_{DD} = 15V$	—	510	700		$T_A = +25^\circ C$
		—	560	—		$0 \leq T_A \leq +70^\circ C$
		—	650	—		$-55^\circ C \leq T_A \leq +125^\circ C$
	$V_{DD} = 5V$	—	190	—		$T_A = +25^\circ C$
		—	210	—		$0 \leq T_A \leq +70^\circ C$
		—	210	—		$-55^\circ C \leq T_A \leq +125^\circ C$
R_O	Output Source Resistance	—	32	37	Ω	$I_L = 20\text{ mA}$, $V_{DD} = 15V$
		—	35	40		$I_L = 80\text{ mA}$, $V_{DD} = 15V$
		—	—	50		$I_L = 3\text{ mA}$, $V_{DD} = 5V$
F_{OSC}	Oscillator Frequency	—	12	—	kHz	Pin 6 Open
		—	24	—		Pin 6 GND
P_{EFF}	Power Efficiency	93	97	—	%	$R_L = 2\text{ k}\Omega$
		—	—	—		
V_{DEF}	Voltage Efficiency	99	99.9	—	%	$R_L = \infty$
		—	—	—		Over temperature range
		96	—	—		
V_Z	Zener Voltage	6.0	6.2	6.4	V	$I_Z = 5\text{ mA}$
Z_{ZT}	Zener Impedance	—	12	—	Ω	$I_L = 2.5\text{ mA}$ to 7.5 mA

Note 1: Connecting any input terminal to voltages greater than V^+ or less than GND may cause destructive latch-up. It is recommended that no inputs from sources operating from external supplies be applied prior to "power-up" of the TC962.

TC962

2.0 PIN DESCRIPTIONS

The descriptions of the pins are listed in Table 2-1.

TABLE 2-1: PIN FUNCTION TABLE

Pin No. (8-Pin DIP) (8-Pin CERDIP)	Symbol	Description
1	Zener Cathode	Cathode of internal Zener diode.
2	C ⁺	Positive side of external CP capacitor (pump cap).
3	GND	Ground terminal.
4	C ⁻	Negative side of external CP capacitor (pump cap).
5	V _{OUT}	Output voltage.
6	FREQ x 2	If grounded, frequency doubles.
7	C _{OSC}	Capacitor to GND will decrease frequency.
8	V _{DD}	Input voltage.

Pin No. (16-Pin SOIC)	Symbol	Description
1	Zener Cathode	Cathode of internal Zener diode.
2	NC	No connect.
3	C ⁺	Positive side of external CP capacitor (pump cap).
4	NC	No connect.
5	GND	Ground terminal.
6	NC	No connect.
7	C ⁻	Negative side of external CP capacitor (pump cap).
8	NC	No connect.
9	NC	No connect.
10	V _{OUT}	Output voltage.
11	NC	No connect.
12	FREQ x 2	If grounded, frequency doubles.
13	NC	No connect.
14	C _{OSC}	Capacitor to GND will decrease frequency.
15	NC	No connect.
16	V _{DD}	Input voltage.

3.0 APPLICATIONS INFORMATION

3.1 Theory of Operation

The TC962 is a capacitive pump (sometimes called a switched capacitor circuit), where four MOSFET switches control the charge and discharge of a capacitor.

The functional block diagram shows how the switching action works. SW1 and SW2 are turned on simultaneously, charging C_P to the supply voltage, V_{IN} . This assumes that the on resistance of the MOSFETs in series with the capacitor results in a charging time (3 time constants) that is less than the on time provided by the oscillator frequency as shown:

$$3 (R_{DS(ON)} C_P) < C_P / (0.5 f_{OSC})$$

In the next cycle, SW1 and SW2 are turned off and after a very short interval of all switches being off (this prevents large currents from occurring due to cross conduction), SW3 and SW4 are turned on. The charge in C_P is then transferred to C_R , but with the polarity inverted. In this way, a negative voltage is now derived.

An oscillator supplies pulses to a flip-flop that is then fed to a set of level shifters. These level shifters then drive each set of switches at one-half the oscillator frequency.

The oscillator has two pins that control the frequency of oscillation. Pin 7 can have a capacitor added that is returned to ground. This will lower the frequency of the oscillator by adding capacitance to the timing capacitor internal to the TC962. Grounding pin 6 will turn on a

current source and double the frequency. This will double the charge current going into the internal capacitor, as well as any capacitor added to pin 7.

A Zener diode has been added to the TC962 for use as a reference in building external regulators. This Zener runs from pin 1 to ground.

3.2 Latch-Up

All CMOS structures contain a parasitic SCR. Care must be taken to prevent any input from going above or below the supply rail, or latch-up will occur. The result of latch-up is an effective short between V_{DD} and V_{SS} . Unless the power supply input has a current limit, this latch-up phenomena will result in damage to the device. (See AN763, *Latch-up Protection for MOSFET Drivers*.)

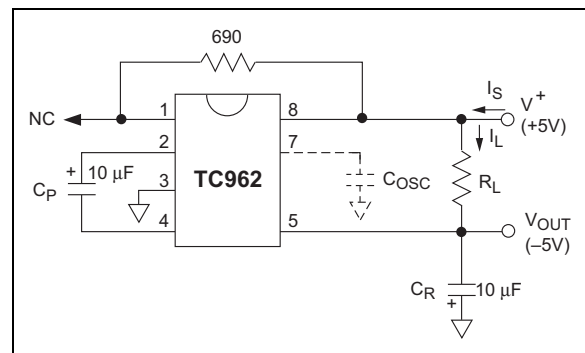

FIGURE 3-1: Test Circuit

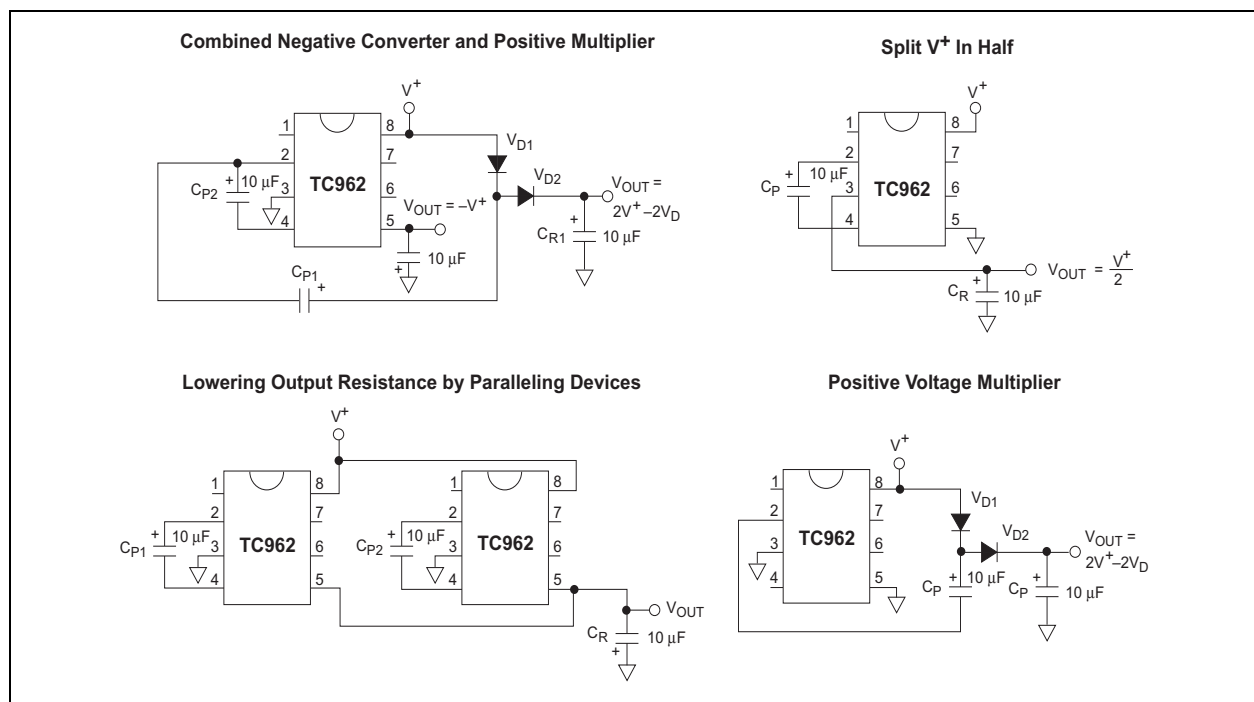

FIGURE 3-2: Typical Applications

TC962

4.0 TYPICAL CHARACTERISTICS

Note: The graphs and tables provided following this note are a statistical summary based on a limited number of samples and are provided for informational purposes only. The performance characteristics listed herein are not tested or guaranteed. In some graphs or tables, the data presented may be outside the specified operating range (e.g., outside specified power supply range) and therefore outside the warranted range.

Circuit of Figure , $C_P = C_R = 10 \mu\text{F}$, $C_{PESR} \approx C_{RESR} \approx 1 \Omega$.

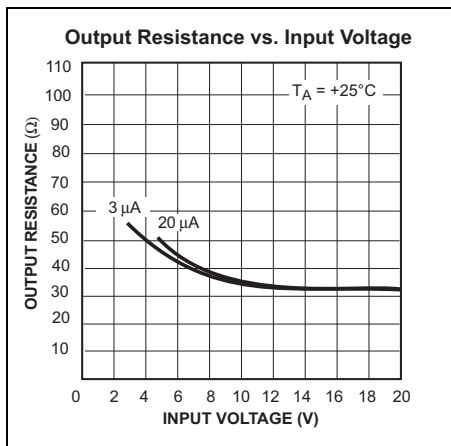
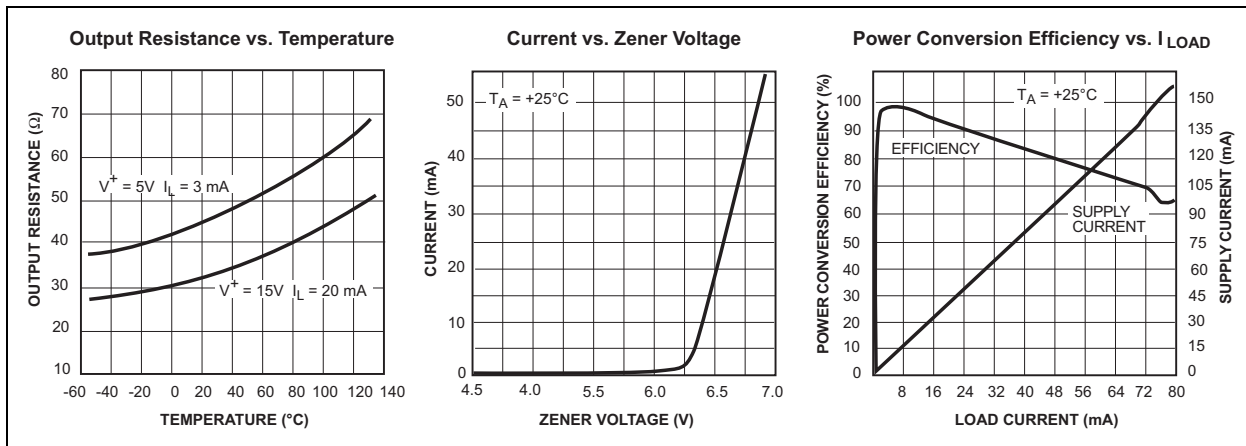
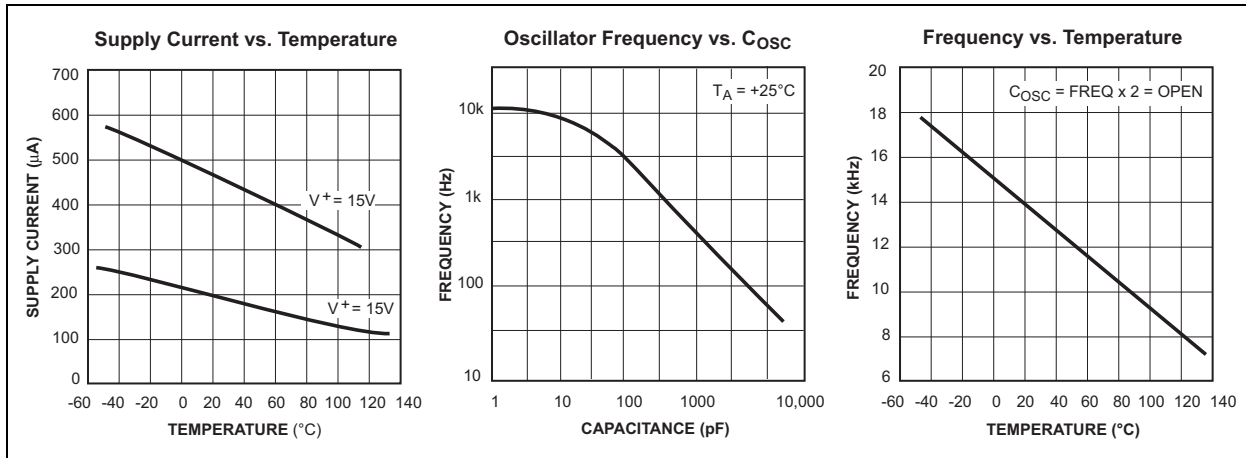

5.0 PACKAGING INFORMATION

5.1 Package Marking Information

Package marking data not available at this time.

5.2 Taping Form

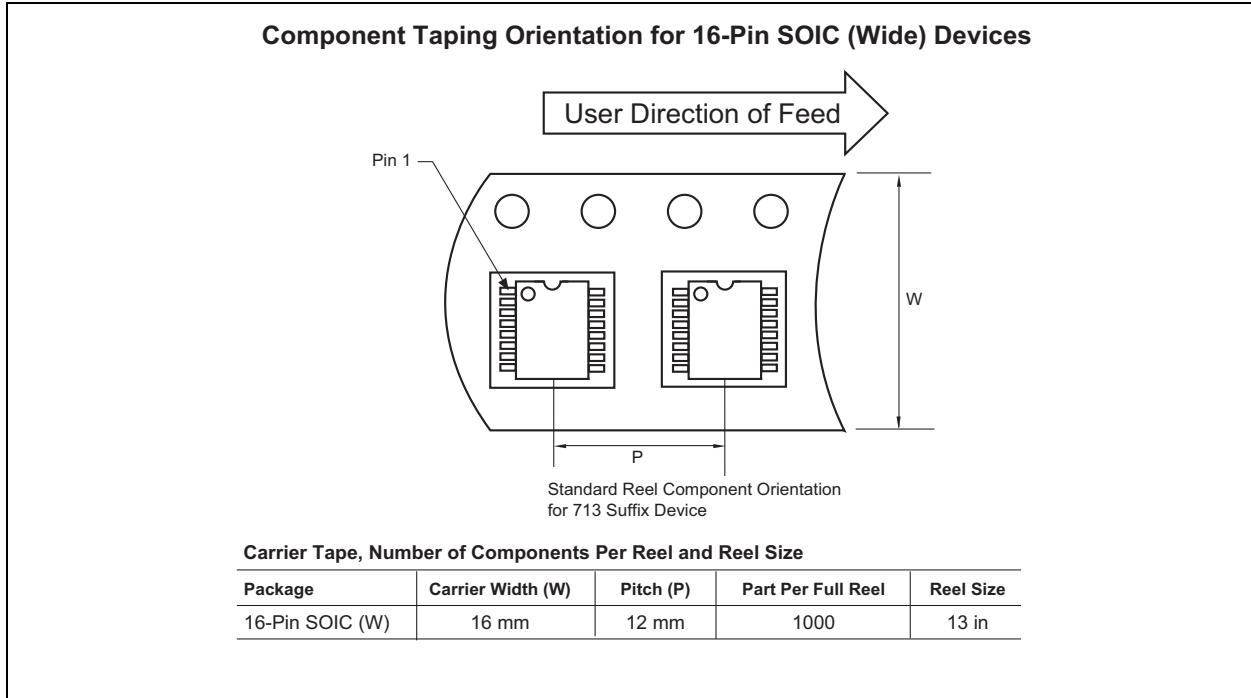

5.3 Package Dimensions

Note: For the most current package drawings, please see the Microchip Packaging Specification located at <http://www.microchip.com/packaging>

8-Pin CDIP (Narrow)

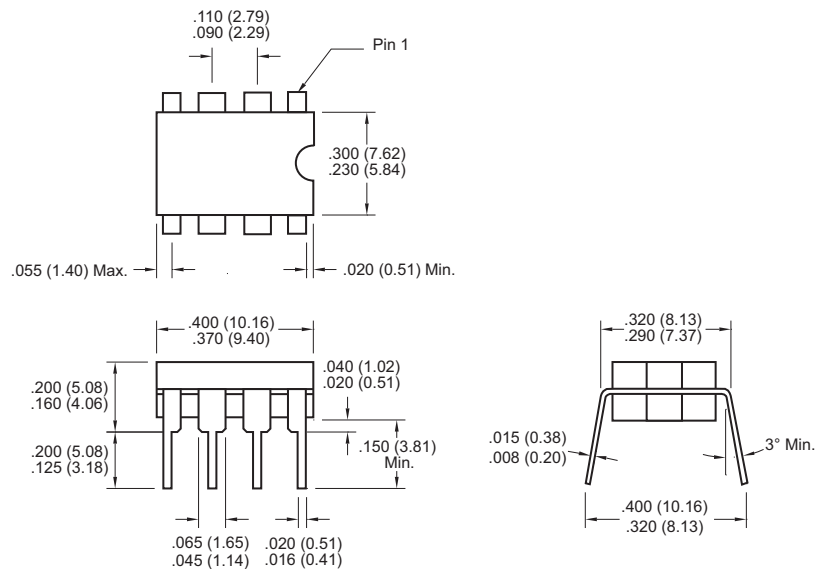

Dimensions: inches (mm)

Package Dimensions (Continued)

Note: For the most current package drawings, please see the Microchip Packaging Specification located at <http://www.microchip.com/packaging>

8-Pin Plastic DIP

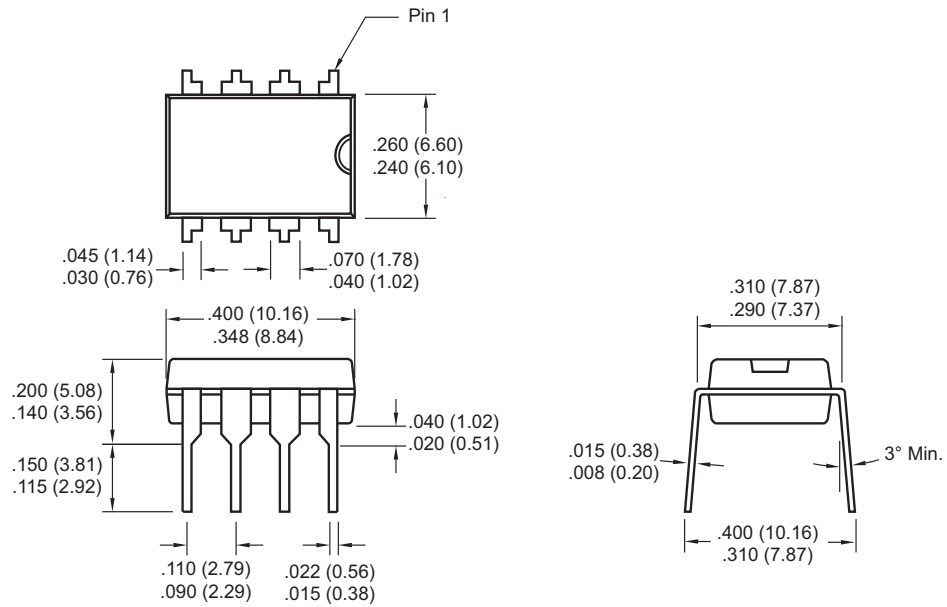

Dimensions: inches (mm)

Note: For the most current package drawings, please see the Microchip Packaging Specification located at <http://www.microchip.com/packaging>

16-Pin SOIC (Wide)

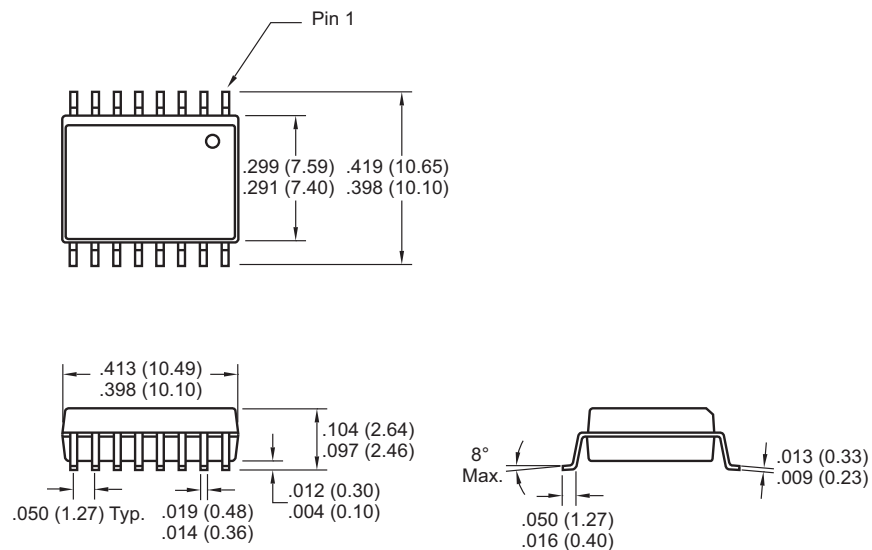

Dimensions: inches (mm)

6.0 REVISION HISTORY

Revision D (December 2012)

Added a note to each package outline drawing.

TC962

NOTES:

THE MICROCHIP WEB SITE

Microchip provides online support via our WWW site at www.microchip.com. This web site is used as a means to make files and information easily available to customers. Accessible by using your favorite Internet browser, the web site contains the following information:

- **Product Support** – Data sheets and errata, application notes and sample programs, design resources, user's guides and hardware support documents, latest software releases and archived software
- **General Technical Support** – Frequently Asked Questions (FAQ), technical support requests, online discussion groups, Microchip consultant program member listing
- **Business of Microchip** – Product selector and ordering guides, latest Microchip press releases, listing of seminars and events, listings of Microchip sales offices, distributors and factory representatives

CUSTOMER CHANGE NOTIFICATION SERVICE

Microchip's customer notification service helps keep customers current on Microchip products. Subscribers will receive e-mail notification whenever there are changes, updates, revisions or errata related to a specified product family or development tool of interest.

To register, access the Microchip web site at www.microchip.com. Under "Support", click on "Customer Change Notification" and follow the registration instructions.

CUSTOMER SUPPORT

Users of Microchip products can receive assistance through several channels:

- Distributor or Representative
- Local Sales Office
- Field Application Engineer (FAE)
- Technical Support

Customers should contact their distributor, representative or field application engineer (FAE) for support. Local sales offices are also available to help customers. A listing of sales offices and locations is included in the back of this document.

Technical support is available through the web site at: <http://microchip.com/support>

READER RESPONSE

It is our intention to provide you with the best documentation possible to ensure successful use of your Microchip product. If you wish to provide your comments on organization, clarity, subject matter, and ways in which our documentation can better serve you, please FAX your comments to the Technical Publications Manager at (480) 792-4150.

Please list the following information, and use this outline to provide us with your comments about this document.

TO: Technical Publications Manager Total Pages Sent _____

RE: Reader Response

From: Name _____

Company _____

Address _____

City / State / ZIP / Country _____

Telephone: (_____) _____ - _____ FAX: (_____) _____ - _____

Application (optional):

Would you like a reply? Y N

Device: TC962

Literature Number: DS21484D

Questions:

1. What are the best features of this document?

2. How does this document meet your hardware and software development needs?

3. Do you find the organization of this document easy to follow? If not, why?

4. What additions to the document do you think would enhance the structure and subject?

5. What deletions from the document could be made without affecting the overall usefulness?

6. Is there any incorrect or misleading information (what and where)?

7. How would you improve this document?

Note the following details of the code protection feature on Microchip devices:

- Microchip products meet the specification contained in their particular Microchip Data Sheet.
- Microchip believes that its family of products is one of the most secure families of its kind on the market today, when used in the intended manner and under normal conditions.
- There are dishonest and possibly illegal methods used to breach the code protection feature. All of these methods, to our knowledge, require using the Microchip products in a manner outside the operating specifications contained in Microchip's Data Sheets. Most likely, the person doing so is engaged in theft of intellectual property.
- Microchip is willing to work with the customer who is concerned about the integrity of their code.
- Neither Microchip nor any other semiconductor manufacturer can guarantee the security of their code. Code protection does not mean that we are guaranteeing the product as “unbreakable.”

Code protection is constantly evolving. We at Microchip are committed to continuously improving the code protection features of our products. Attempts to break Microchip's code protection feature may be a violation of the Digital Millennium Copyright Act. If such acts allow unauthorized access to your software or other copyrighted work, you may have a right to sue for relief under that Act.

Information contained in this publication regarding device applications and the like is provided only for your convenience and may be superseded by updates. It is your responsibility to ensure that your application meets with your specifications. MICROCHIP MAKES NO REPRESENTATIONS OR WARRANTIES OF ANY KIND WHETHER EXPRESS OR IMPLIED, WRITTEN OR ORAL, STATUTORY OR OTHERWISE, RELATED TO THE INFORMATION, INCLUDING BUT NOT LIMITED TO ITS CONDITION, QUALITY, PERFORMANCE, MERCHANTABILITY OR FITNESS FOR PURPOSE. Microchip disclaims all liability arising from this information and its use. Use of Microchip devices in life support and/or safety applications is entirely at the buyer's risk, and the buyer agrees to defend, indemnify and hold harmless Microchip from any and all damages, claims, suits, or expenses resulting from such use. No licenses are conveyed, implicitly or otherwise, under any Microchip intellectual property rights.

Trademarks

The Microchip name and logo, the Microchip logo, dsPIC, FlashFlex, KEELOQ, KEELOQ logo, MPLAB, PIC, PICmicro, PICSTART, PIC³² logo, rPIC, SST, SST Logo, SuperFlash and UNI/O are registered trademarks of Microchip Technology Incorporated in the U.S.A. and other countries.

FilterLab, Hampshire, HI-TECH C, Linear Active Thermistor, MTP, SEEVAL and The Embedded Control Solutions Company are registered trademarks of Microchip Technology Incorporated in the U.S.A.

Silicon Storage Technology is a registered trademark of Microchip Technology Inc. in other countries.

Analog-for-the-Digital Age, Application Maestro, BodyCom, chipKIT, chipKIT logo, CodeGuard, dsPICDEM, dsPICDEM.net, dsPICworks, dsSPEAK, ECAN, ECONOMONITOR, FanSense, HI-TIDE, In-Circuit Serial Programming, ICSP, Mindi, MiWi, MPASM, MPF, MPLAB Certified logo, MPLIB, MPLINK, mTouch, Omniclient Code Generation, PICC, PICC-18, PICDEM, PICDEM.net, PICkit, PICtail, REAL ICE, rLAB, Select Mode, SQI, Serial Quad I/O, Total Endurance, TSHARC, UniWinDriver, WiperLock, ZENA and Z-Scale are trademarks of Microchip Technology Incorporated in the U.S.A. and other countries.

SQTP is a service mark of Microchip Technology Incorporated in the U.S.A.

GestIC and ULPP are registered trademarks of Microchip Technology Germany II GmbH & Co. & KG, a subsidiary of Microchip Technology Inc., in other countries.

All other trademarks mentioned herein are property of their respective companies.

© 2001-2012, Microchip Technology Incorporated, Printed in the U.S.A., All Rights Reserved.

 Printed on recycled paper.

ISBN: 9781620768808

QUALITY MANAGEMENT SYSTEM
CERTIFIED BY DNV
== ISO/TS 16949 ==

Microchip received ISO/TS-16949:2009 certification for its worldwide headquarters, design and wafer fabrication facilities in Chandler and Tempe, Arizona; Gresham, Oregon and design centers in California and India. The Company's quality system processes and procedures are for its PIC[®] MCUs and dsPIC[®] DSCs, KEELOQ[®] code hopping devices, Serial EEPROMs, microperipherals, nonvolatile memory and analog products. In addition, Microchip's quality system for the design and manufacture of development systems is ISO 9001:2000 certified.



MICROCHIP

Worldwide Sales and Service

AMERICAS

Corporate Office
2355 West Chandler Blvd.
Chandler, AZ 85224-6199
Tel: 480-792-7200
Fax: 480-792-7277
Technical Support:
<http://www.microchip.com/support>
Web Address:
www.microchip.com

Atlanta
Duluth, GA
Tel: 678-957-9614
Fax: 678-957-1455

Boston
Westborough, MA
Tel: 774-760-0087
Fax: 774-760-0088

Chicago
Itasca, IL
Tel: 630-285-0071
Fax: 630-285-0075

Cleveland
Independence, OH
Tel: 216-447-0464
Fax: 216-447-0643

Dallas
Addison, TX
Tel: 972-818-7423
Fax: 972-818-2924

Detroit
Farmington Hills, MI
Tel: 248-538-2250
Fax: 248-538-2260

Indianapolis
Noblesville, IN
Tel: 317-773-8323
Fax: 317-773-5453

Los Angeles
Mission Viejo, CA
Tel: 949-462-9523
Fax: 949-462-9608

Santa Clara
Santa Clara, CA
Tel: 408-961-6444
Fax: 408-961-6445

Toronto
Mississauga, Ontario,
Canada
Tel: 905-673-0699
Fax: 905-673-6509

ASIA/PACIFIC

Asia Pacific Office
Suites 3707-14, 37th Floor
Tower 6, The Gateway
Harbour City, Kowloon
Hong Kong
Tel: 852-2401-1200
Fax: 852-2401-3431

Australia - Sydney
Tel: 61-2-9868-6733
Fax: 61-2-9868-6755

China - Beijing
Tel: 86-10-8569-7000
Fax: 86-10-8528-2104

China - Chengdu
Tel: 86-28-8665-5511
Fax: 86-28-8665-7889

China - Chongqing
Tel: 86-23-8980-9588
Fax: 86-23-8980-9500

China - Hangzhou
Tel: 86-571-2819-3187
Fax: 86-571-2819-3189

China - Hong Kong SAR
Tel: 852-2943-5100
Fax: 852-2401-3431

China - Nanjing
Tel: 86-25-8473-2460
Fax: 86-25-8473-2470

China - Qingdao
Tel: 86-532-8502-7355
Fax: 86-532-8502-7205

China - Shanghai
Tel: 86-21-5407-5533
Fax: 86-21-5407-5066

China - Shenyang
Tel: 86-24-2334-2829
Fax: 86-24-2334-2393

China - Shenzhen
Tel: 86-755-8864-2200
Fax: 86-755-8203-1760

China - Wuhan
Tel: 86-27-5980-5300
Fax: 86-27-5980-5118

China - Xian
Tel: 86-29-8833-7252
Fax: 86-29-8833-7256

China - Xiamen
Tel: 86-592-2388138
Fax: 86-592-2388130

China - Zhuhai
Tel: 86-756-3210040
Fax: 86-756-3210049

ASIA/PACIFIC

India - Bangalore
Tel: 91-80-3090-4444
Fax: 91-80-3090-4123

India - New Delhi
Tel: 91-11-4160-8631
Fax: 91-11-4160-8632

India - Pune
Tel: 91-20-2566-1512
Fax: 91-20-2566-1513

Japan - Osaka
Tel: 81-6-6152-7160
Fax: 81-6-6152-9310

Japan - Tokyo
Tel: 81-3-6880-3770
Fax: 81-3-6880-3771

Korea - Daegu
Tel: 82-53-744-4301
Fax: 82-53-744-4302

Korea - Seoul
Tel: 82-2-554-7200
Fax: 82-2-558-5932 or
82-2-558-5934

Malaysia - Kuala Lumpur
Tel: 60-3-6201-9857
Fax: 60-3-6201-9859

Malaysia - Penang
Tel: 60-4-227-8870
Fax: 60-4-227-4068

Philippines - Manila
Tel: 63-2-634-9065
Fax: 63-2-634-9069

Singapore
Tel: 65-6334-8870
Fax: 65-6334-8850

Taiwan - Hsin Chu
Tel: 886-3-5778-366
Fax: 886-3-5770-955

Taiwan - Kaohsiung
Tel: 886-7-213-7828
Fax: 886-7-330-9305

Taiwan - Taipei
Tel: 886-2-2508-8600
Fax: 886-2-2508-0102

Thailand - Bangkok
Tel: 66-2-694-1351
Fax: 66-2-694-1350

EUROPE

Austria - Wels
Tel: 43-7242-2244-39
Fax: 43-7242-2244-393

Denmark - Copenhagen
Tel: 45-4450-2828
Fax: 45-4485-2829

France - Paris
Tel: 33-1-69-53-63-20
Fax: 33-1-69-30-90-79

Germany - Munich
Tel: 49-89-627-144-0
Fax: 49-89-627-144-44

Italy - Milan
Tel: 39-0331-742611
Fax: 39-0331-466781

Netherlands - Drunen
Tel: 31-416-690399
Fax: 31-416-690340

Spain - Madrid
Tel: 34-91-708-08-90
Fax: 34-91-708-08-91

UK - Wokingham
Tel: 44-118-921-5869
Fax: 44-118-921-5820

11/29/12



Компания «ЭлектроПласт» предлагает заключение долгосрочных отношений при поставках импортных электронных компонентов на взаимовыгодных условиях!

Наши преимущества:

- Оперативные поставки широкого спектра электронных компонентов отечественного и импортного производства напрямую от производителей и с крупнейших мировых складов;
- Поставка более 17-ти миллионов наименований электронных компонентов;
- Поставка сложных, дефицитных, либо снятых с производства позиций;
- Оперативные сроки поставки под заказ (от 5 рабочих дней);
- Экспресс доставка в любую точку России;
- Техническая поддержка проекта, помощь в подборе аналогов, поставка прототипов;
- Система менеджмента качества сертифицирована по Международному стандарту ISO 9001;
- Лицензия ФСБ на осуществление работ с использованием сведений, составляющих государственную тайну;
- Поставка специализированных компонентов (Xilinx, Altera, Analog Devices, Intersil, Interpoint, Microsemi, Aeroflex, Peregrine, Syfer, Eurofarad, Texas Instrument, Miteq, Cobham, E2V, MA-COM, Hittite, Mini-Circuits, General Dynamics и др.);

Помимо этого, одним из направлений компании «ЭлектроПласт» является направление «Источники питания». Мы предлагаем Вам помощь Конструкторского отдела:

- Подбор оптимального решения, техническое обоснование при выборе компонента;
- Подбор аналогов;
- Консультации по применению компонента;
- Поставка образцов и прототипов;
- Техническая поддержка проекта;
- Защита от снятия компонента с производства.



Как с нами связаться

Телефон: 8 (812) 309 58 32 (многоканальный)

Факс: 8 (812) 320-02-42

Электронная почта: org@eplast1.ru

Адрес: 198099, г. Санкт-Петербург, ул. Калинина, дом 2, корпус 4, литера А.