

Knob Potentiometer



The P16 is a revolutionary concept in panel mounted potentiometers. This unique design consists of a knob driving and incorporating a cermet potentiometer. Only the mounting hardware and terminals are situated on the back side of the panel reducing to a minimum the required clearance.

FEATURES

- Test according to CECC 41000 or IEC 60393-1
- **P16** - Version for professional and industrial applications (cermet)
1 W at 40 °C
- **PA16** - Version for professional audio applications (conductive plastic)
0.5 W at 40 °C
- Compact (integrated)
- High dielectric strength: 2500 V_{RMS}
- Fully sealed and panel sealed
- Metallic or plastic knob options
- Custom knob on request
- Compliant to RoHS Directive 2002/95/EC



DIMENSIONS in millimeters (± 0.5 mm)

P16, PA16

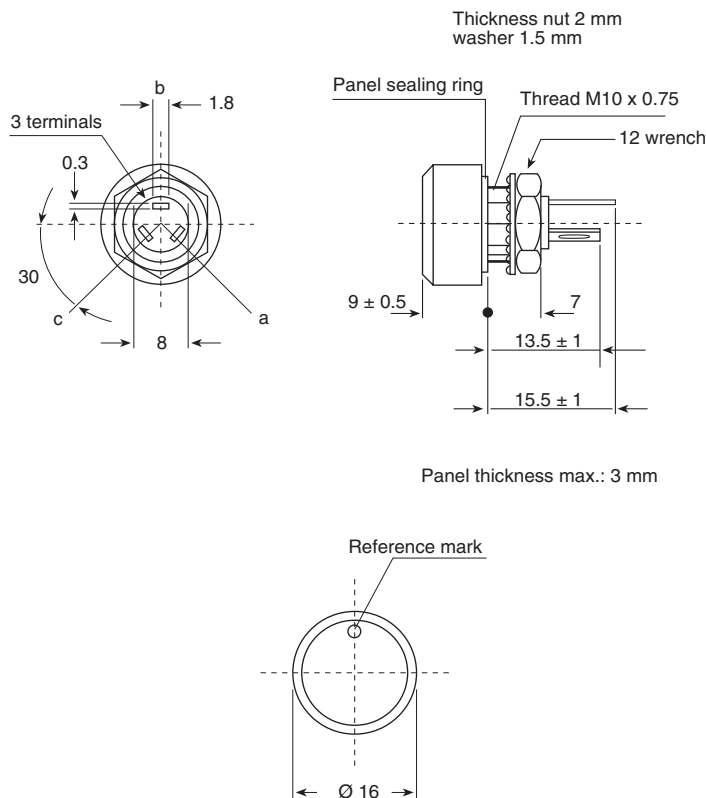

PANEL CUTOUT

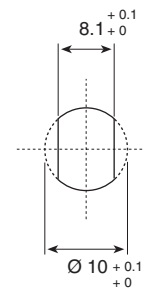

ELECTRICAL SPECIFICATIONS		
	P16	PA16
Resistive Element	Cermet	Conductive plastic
Electrical Travel	270° ± 10°	270° ± 10°
Power Rating Chart		
Circuit Diagram		
Taper		
Resistance Range	Linear Taper 22 Ω to 10 MΩ Logarithmic Taper 100 Ω to 2.2 MΩ	1 kΩ to 1 MΩ 470 Ω to 500 kΩ
Standard Series E3	1 - 2.2 - 4.7 and on request 1 - 2 - 5	1 - 2.2 - 4.7
Tolerance	Standard ± 20 % On Request ± 10 %	± 20 % ± 10 % (1 kΩ to 100 kΩ)
Power Rating	Linear 1 W at + 40 °C 0.5 W at + 40 °C Logarithmic	0.5 W at + 40 °C 0.25 W at + 40 °C
Temperature Coefficient (Typical)	± 150 ppm/°C	± 500 ppm/°C
Dielectric Strength (RMS)	2500 V	2500 V
Limiting Element Voltage (Linear Law)	350 V	350 V
Contact Resistance Variation	3 % Rn or 3 Ω	2 % Rn or 3 Ω
End Resistance (Typical)	1 Ω	1 Ω
Insulation Resistance (500 V _{DC})	10 ⁶ MΩ	10 ⁶ MΩ



MECHANICAL SPECIFICATIONS	
Mechanical Travel	300° ± 5°
Operating Torque	2 Ncm typical
End Stop Torque	25 Ncm maximum
Max. Tightening Torque of Mounting Nut	250 Ncm maximum
Unit Weight	4.5 g typical

ENVIRONMENTAL SPECIFICATIONS		
	Metallic Knob	Plastic Knob
Temperature Range	- 40 °C to 125 °C	- 40 °C to 85 °C
Climatic Category	40/100/56	40/85/56
Sealing	Sealed container and panel sealed	
Protection Grades	IP67	

MARKING
<ul style="list-style-type: none"> Ohmic value code, tolerance code and taper Manufacturing date code

PACKAGING
<ul style="list-style-type: none"> Carton box of 20 pieces

CONTROL KNOB
Black metallic knob (NM).
Black plastic knob (NP).
For white and blue color see ordering information.
Other dimensions, shapes, colors of control knobs are manufactured on request - please consult Vishay.
Other reference marks (shapes, colors) and legends can be printed on plastic knob on request - please consult Vishay.

P16 STANDARD RESISTANCE ELEMENT DATA						
STANDARD RESISTANCE VALUES	LINEAR TAPER			LOG TAPER		
	MAX. POWER AT 40 °C	MAX. VOLTAGE	MAX. CUR. THROUGH WIPER	MAX. POWER AT 40 °C	MAX. VOLTAGE	MAX. CUR. THROUGH WIPER
Ω	W	V	mA	W	V	mA
22	1	4.69	213			
47	1	6.85	146			
100	1	10	100	0.5	7.1	71
220	1	14.8	67.4	0.5	10.5	48
470	1	21.7	46.1	0.5	15.3	32.6
1K	1	31.6	31.6	0.5	22.4	22.4
2.2K	1	46.9	21.3	0.5	33.2	15.1
4.7K	1	68.5	14.6	0.5	48.5	10.3
10K	1	100	10	0.5	70.7	7.07
22K	1	148	6.74	0.5	105	4.77
47K	1	217	4.61	0.5	153	3.26
100K	1	316	3.16	0.5	224	2.24
220K	0.56	350	1.59	0.5	332	1.51
470K	0.26	350	0.75	0.26	350	0.74
1M	0.12	350	0.35	0.12	350	0.35
2.2M	0.05	350	0.16	0.056	350	0.16
4.7M	0.02	350	0.07			
10M	0.01	350	0.012			

PA16 STANDARD RESISTANCE ELEMENT DATA						
STANDARD RESISTANCE VALUES	LINEAR TAPER			LOG TAPER		
	MAX. POWER AT 40 °C	MAX. VOLTAGE	MAX. CUR. THROUGH WIPER	MAX. POWER AT 70 °C	MAX. VOLTAGE	MAX. CUR. THROUGH WIPER
Ω	W	V	mA	W	V	mA
470				0.25	10.8	23.1
1K	0.5	22.4	22.4	0.25	15.8	16
2.2K	0.5	33.2	15.1	0.25	23.5	11
4.7K	0.5	48.5	10.3	0.25	34.3	7
10K	0.5	79.7	7.07	0.25	50.0	5.0
22K	0.5	105	4.77	0.25	74	3.4
47K	0.5	153	3.26	0.25	108	2.3
100K	0.5	224	2.24	0.25	158	1.6
220K	0.5	332	1.51	0.25	235	1.1
470K	0.26	350	0.74	0.25	343	0.7
1M	0.12	350	0.35			



PERFORMANCE				
TESTS	CONDITIONS	TYPICAL VALUES AND DRIFTS		
		$\Delta R_T/R_T$ (%)	$\Delta R_{1-2}/R_{1-2}$ (%)	OTHER
Electrical Endurance	1000 h at rated power 90°/30° cycle at + 40 °C	± 5 %	-	Insulation resistance: > 10 ⁴ MΩ Contact res. variation: < 2 % Rn
Damp Heat, Steady State	56 days 40 °C, 93 % HR	± 2 %	± 1 %	Insulation resistance: > 10 ⁴ MΩ
Mechanical Endurance	50 000 cycles	± 5 %	-	Contact res. variation: < 2 % Rn
Shock	50 g's at 11 ms 3 successive shocks in 3 directions	± 0.2 %	± 0.5 %	-
Vibration	10 Hz to 55 Hz 0.75 mm or 10 g's during 6 h	± 0.2 %	-	$\Delta V_{1-2}/\Delta V_{1-3} \leq \pm 0.5 \%$

ORDERING INFORMATION														
P	1	6	N	P	2	2	3	M	A	B	1	5		
MODEL	STYLE			OHMIC VALUE	TOLERANCE	TAPER		PACKAGING CODE	SPECIAL NUMBER					
P16 = Cermet PA16 = Conductive plastic	NM : Metallic black NP : Plastic black WM : Metallic white WP : Plastic white BP : Plastic blue			223 = 22 kΩ for ohmic value range see electrical specification	M = ± 20 % On request: K = ± 10 %	A : Linear L : Clockwise logarithmic F : Inverse clockwise logarithmic		B15 = Box of 20 pieces	(If applicable) Given by Vishay for custom design					

PART NUMBER DESCRIPTION (for information only)								
P16	NP	22 kΩ	20 %	A		BO		e3
MODEL	STYLE	VALUE	TOLERANCE	TAPER	SPECIAL	PACKAGING	SPECIAL	LEAD (Pb)-FREE



Disclaimer

ALL PRODUCT, PRODUCT SPECIFICATIONS AND DATA ARE SUBJECT TO CHANGE WITHOUT NOTICE TO IMPROVE RELIABILITY, FUNCTION OR DESIGN OR OTHERWISE.

Vishay Intertechnology, Inc., its affiliates, agents, and employees, and all persons acting on its or their behalf (collectively, "Vishay"), disclaim any and all liability for any errors, inaccuracies or incompleteness contained in any datasheet or in any other disclosure relating to any product.

Vishay makes no warranty, representation or guarantee regarding the suitability of the products for any particular purpose or the continuing production of any product. To the maximum extent permitted by applicable law, Vishay disclaims (i) any and all liability arising out of the application or use of any product, (ii) any and all liability, including without limitation special, consequential or incidental damages, and (iii) any and all implied warranties, including warranties of fitness for particular purpose, non-infringement and merchantability.

Statements regarding the suitability of products for certain types of applications are based on Vishay's knowledge of typical requirements that are often placed on Vishay products in generic applications. Such statements are not binding statements about the suitability of products for a particular application. It is the customer's responsibility to validate that a particular product with the properties described in the product specification is suitable for use in a particular application. Parameters provided in datasheets and/or specifications may vary in different applications and performance may vary over time. All operating parameters, including typical parameters, must be validated for each customer application by the customer's technical experts. Product specifications do not expand or otherwise modify Vishay's terms and conditions of purchase, including but not limited to the warranty expressed therein.

Except as expressly indicated in writing, Vishay products are not designed for use in medical, life-saving, or life-sustaining applications or for any other application in which the failure of the Vishay product could result in personal injury or death. Customers using or selling Vishay products not expressly indicated for use in such applications do so at their own risk. Please contact authorized Vishay personnel to obtain written terms and conditions regarding products designed for such applications.

No license, express or implied, by estoppel or otherwise, to any intellectual property rights is granted by this document or by any conduct of Vishay. Product names and markings noted herein may be trademarks of their respective owners.

Material Category Policy

Vishay Intertechnology, Inc. hereby certifies that all its products that are identified as RoHS-Compliant fulfill the definitions and restrictions defined under Directive 2011/65/EU of The European Parliament and of the Council of June 8, 2011 on the restriction of the use of certain hazardous substances in electrical and electronic equipment (EEE) - recast, unless otherwise specified as non-compliant.

Please note that some Vishay documentation may still make reference to RoHS Directive 2002/95/EC. We confirm that all the products identified as being compliant to Directive 2002/95/EC conform to Directive 2011/65/EU.

Vishay Intertechnology, Inc. hereby certifies that all its products that are identified as Halogen-Free follow Halogen-Free requirements as per JEDEC JS709A standards. Please note that some Vishay documentation may still make reference to the IEC 61249-2-21 definition. We confirm that all the products identified as being compliant to IEC 61249-2-21 conform to JEDEC JS709A standards.



Компания «ЭлектроПласт» предлагает заключение долгосрочных отношений при поставках импортных электронных компонентов на взаимовыгодных условиях!

Наши преимущества:

- Оперативные поставки широкого спектра электронных компонентов отечественного и импортного производства напрямую от производителей и с крупнейших мировых складов;
- Поставка более 17-ти миллионов наименований электронных компонентов;
- Поставка сложных, дефицитных, либо снятых с производства позиций;
- Оперативные сроки поставки под заказ (от 5 рабочих дней);
- Экспресс доставка в любую точку России;
- Техническая поддержка проекта, помощь в подборе аналогов, поставка прототипов;
- Система менеджмента качества сертифицирована по Международному стандарту ISO 9001;
- Лицензия ФСБ на осуществление работ с использованием сведений, составляющих государственную тайну;
- Поставка специализированных компонентов (Xilinx, Altera, Analog Devices, Intersil, Interpoint, Microsemi, Aeroflex, Peregrine, Syfer, Eurofarad, Texas Instrument, Miteq, Cobham, E2V, MA-COM, Hittite, Mini-Circuits, General Dynamics и др.);

Помимо этого, одним из направлений компании «ЭлектроПласт» является направление «Источники питания». Мы предлагаем Вам помощь Конструкторского отдела:

- Подбор оптимального решения, техническое обоснование при выборе компонента;
- Подбор аналогов;
- Консультации по применению компонента;
- Поставка образцов и прототипов;
- Техническая поддержка проекта;
- Защита от снятия компонента с производства.



Как с нами связаться

Телефон: 8 (812) 309 58 32 (многоканальный)

Факс: 8 (812) 320-02-42

Электронная почта: org@eplast1.ru

Адрес: 198099, г. Санкт-Петербург, ул. Калинина, дом 2, корпус 4, литера А.