

## Product Specification

### 16GFC RoHS Compliant Long-Wavelength SFP+ Transceiver

### FTLF1429P3BCV

#### PRODUCT FEATURES

- Up to 14.025 Gb/s bi-directional data links
- Hot-pluggable SFP+ footprint
- Built-in digital diagnostic functions
- 1310nm DFB laser transmitter
- Duplex LC connector
- RoHS compliant and Lead Free
- Up to 10 km on 9/125µm SMF
- Metal enclosure, for lower EMI
- 1W maximum power consumption with established link
- Single 3.3V power supply
- Extended operating temperature range: 0°C to 70°C



#### APPLICATIONS

- Tri Rate 4.25 / 8.5 / 14.025 Gb/s Fibre Channel through Rate Select
- 10GBASE-LR/LW 10G Ethernet

Finisar's FTLF1429P3BCV SFP+ transceivers are designed for use in Fibre Channel links up to 14.025 Gb/s data rate and up to 10 km link length. They are compliant with FC-PI-5 Rev. 6.10<sup>1</sup> and SFF-8472 Rev 11.0<sup>3</sup> and SFF-8081<sup>7</sup>. They are compatible with SFF-8432<sup>2</sup> and applicable portions of SFF-8431 Rev. 4.1<sup>4</sup>. The optical transceivers are compliant per the RoHS Directive 2011/65/EU. See Finisar Application Note AN-2038 for more details.

#### PRODUCT SELECTION

**FTLF1429P3BCV**

## I. Pin Descriptions

Pin	Symbol	Name/Description	Ref.
1	V <sub>EET</sub>	Transmitter Ground (Common with Receiver Ground)	1
2	T <sub>FAULT</sub>	Transmitter Fault.	2
3	T <sub>DIS</sub>	Transmitter Disable. Laser output disabled on high or open.	3
4	SDA	2-wire Serial Interface Data Line (MOD-DEF2)	4
5	SCA	2-wire Serial Interface Clock (MOD-DEF1)	4
6	MOD_ABS	Module Absent, connected to V <sub>EET</sub> or V <sub>EER</sub>	4
7	RS0	Rx Rate Select: Open or Low = 4.25 or 8.5 Gb/s Fibre Channel (Low Bandwidth) High = 14.025 Gb/s Fibre Channel (High Bandwidth)	5
8	LOS	Loss of Signal indication. Logic 0 indicates normal operation.	6
9	RS1	Tx Rate Select: Open or Low = 4.25 or 8.5 Gb/s Fibre Channel (Low Bandwidth) High = 14.025 Gb/s Fibre Channel (High Bandwidth)	5
10	V <sub>EER</sub>	Receiver Ground (Common with Transmitter Ground)	1
11	V <sub>EER</sub>	Receiver Ground (Common with Transmitter Ground)	1
12	RD-	Receiver Inverted DATA out. AC Coupled	
13	RD+	Receiver Non-inverted DATA out. AC Coupled	
14	V <sub>EER</sub>	Receiver Ground (Common with Transmitter Ground)	1
15	V <sub>CCR</sub>	Receiver Power Supply	
16	V <sub>CCT</sub>	Transmitter Power Supply	
17	V <sub>EET</sub>	Transmitter Ground (Common with Receiver Ground)	1
18	TD+	Transmitter Non-Inverted DATA in. AC Coupled.	
19	TD-	Transmitter Inverted DATA in. AC Coupled.	
20	V <sub>EET</sub>	Transmitter Ground (Common with Receiver Ground)	1

### Notes:

- Circuit ground is internally isolated from chassis ground.
- T<sub>FAULT</sub> is an open collector/drain output, which should be pulled up with a 4.7k – 10k Ohms resistor on the host board if intended for use. Pull up voltage should be between 2.0V to V<sub>cc</sub> + 0.3V. A high output indicates a transmitter fault caused by either the TX bias current or the TX output power exceeding the preset alarm thresholds. A low output indicates normal operation. In the low state, the output is pulled to <0.8V.
- Laser output disabled on T<sub>DIS</sub> >2.0V or open, enabled on T<sub>DIS</sub> <0.8V.
- Should be pulled up with 4.7k – 10kohms on host board to a voltage between 2.0V and 3.6V. MOD\_ABS pulls line low to indicate module is plugged in.
- Rate select can also be set through the 2-wire bus in accordance with SFF-8472 v. 10.2. Rx Rate Select is set at Bit 3, Byte 110, Address A2h. Tx Rate Select is set at Bit 3, Byte 118, Address A2h. Note: writing a “1” selects maximum bandwidth operation. Rate select is the logic OR of the input state of Rate Select Pin and 2-wire bus.
- LOS is open collector output. Should be pulled up with 4.7k – 10kohms on host board to a voltage between 2.0V and 3.6V. Logic 0 indicates normal operation; logic 1 indicates loss of signal.



Pinout of Connector Block on Host Board

## II. Absolute Maximum Ratings

Parameter	Symbol	Min	Typ	Max	Unit	Ref.
Maximum Supply Voltage	V <sub>CC</sub>	-0.5		4.2	V	
Storage Temperature	T <sub>S</sub>	-40		85	°C	
Case Operating Temperature	T <sub>OP</sub>	0		70	°C	
Relative Humidity	RH	0		85	%	1

## III. Electrical Characteristics (T<sub>OP</sub> = -5 to 85 °C, V<sub>CC</sub> = 3.00 to 3.60 Volts)

Parameter	Symbol	Min	Typ	Max	Unit	Ref.
Supply Voltage	V <sub>CC</sub>	3.15		3.45	V	2
Supply Current	I <sub>CC</sub>		200	300	mA	2
<b>Transmitter</b>						
Input differential impedance	R <sub>in</sub>		100		Ω	3
Single ended data input swing	V <sub>in,pp</sub>	90		350	mV	
Transmit Disable Voltage	V <sub>D</sub>	2		V <sub>CC</sub> T+0.3	V	
Transmit Enable Voltage	V <sub>EN</sub>	V <sub>EE</sub>		V <sub>EE</sub> + 0.8	V	4
<b>Receiver</b>						
Single ended data output swing	V <sub>out,pp</sub>	185		425	mV	5
Data output rise/fall time, 4.25 Gb/s	t <sub>r</sub> , t <sub>f</sub>			120	ps	6
LOS Fault	V <sub>LOS fault</sub>	2		V <sub>CC</sub> HOST	V	7
LOS Normal	V <sub>LOS norm</sub>	V <sub>EE</sub> -0.3		V <sub>EE</sub> +0.4	V	7
Power Supply Rejection	PSR	66			mVpp	8

### Notes:

1. Non-condensing.
2. Module power consumption never exceeds 1W with established link.
3. AC coupled.
4. Or open circuit.
5. Into 100 ohm differential termination.
6. 20 – 80 %.
7. LOS is LVTTTL. Logic 0 indicates normal operation; logic 1 indicates no signal detected.
8. All transceiver specifications are compliant with a power supply sinusoidal modulation of 20 Hz to 1.5 MHz up to specified value applied through the power supply filtering network shown on page 23 of the

Small Form-factor Pluggable (SFP) Transceiver MultiSource Agreement (MSA)<sup>6</sup>, September 14, 2000. The Power Supply Rejection applies for a supply voltage range of 3.1 to 3.6 V.

9. Measured with DJ-free data input signal. In actual application, output DJ will be the sum of input DJ and  $\Delta$  DJ.
10. For 14.025 and 8.5 Gb/s operation, Deterministic Jitter and Total Jitter are not specified per FC-PI-5 Rev 6.10. Jitter values for gamma T and gamma R are controlled by TDP and stressed receiver sensitivity.

#### IV. Optical Characteristics ( $T_{OP} = 0$ to $70$ °C, $V_{CC} = 3.15$ to $3.45$ Volts)

Parameter	Symbol	Min	Typ	Max	Unit	Ref.
<b>Transmitter</b>						
Output Opt. Power, 14.025 Gb/s	$P_{O,RH}$	-5.0		+2.0	dBm	1,2
Output Opt. Power, 4.25, 8.5 Gb/s	$P_{O,RL}$	-5.0		-1.0	dBm	3
Optical Wavelength	$\lambda$	1295		1325	nm	4
Spectral Width	$\sigma$			1	nm	4,5
Optical Modulation Amplitude, 14.025 Gb/s	OMA	631			$\mu$ W	6
Optical Modulation Amplitude, 4.25, 8.5 Gb/s	OMA	290			$\mu$ W	4,6
Transmitter and Dispersion Penalty, 14.025 Gb/s	TDP			4.4	dB	7
Transmitter and Dispersion Penalty, 8.5 Gb/s	TDP			3.2	dB	7
Optical Rise/Fall Time, 4.25 Gb/s	$t_r/ t_f$			90	ps	8
RIN				-130	dB/Hz	
<b>Receiver</b>						
Unstressed Receiver OMA Sensitivity, 14.025 Gb/s	$R_{SENSr}$			0.063	mW	
Unstressed Receiver OMA Sensitivity, 8.5 Gb/s	$R_{SENSr}$			0.042	mW	9
Unstressed Receiver OMA Sensitivity, 4.25 Gb/s	$R_{SENS4}$			0.029	mW	9
Average Received Power	$R_{XMAX}$			+2.0	dBm	
Optical Center Wavelength	$\lambda_c$	1260		1370	nm	
Return Loss		12			dB	
LOS De-Assert	$LOS_D$			-19	dBm	
LOS Assert	$LOS_A$	-30			dBm	
LOS Hysteresis		0.5			dB	

#### Notes:

1. Class 1 Laser Safety per FDA/CDRH and EN (IEC) 60825 regulations.
2. High Bandwidth Mode. Class 1 Laser Safety per FDA/CDRH and EN (IEC) 60825 regulations.
3. Low Bandwidth Mode. Class 1 Laser Safety per FDA/CDRH and EN (IEC) 60825 regulations.
4. Also specified to meet curves in FC-PI-5 Rev 6.10<sup>1</sup> Figures 23, 24, and 25, which allow trade-off between wavelength, spectral width and OMA for 4.25 and 8.5 Gb/s operation.
5. 20dB spectral width.
6. Equivalent extinction ratio specification for Fibre Channel. Allows smaller ER at higher average power.
7. For 14.025 and 8.5 Gb/s operation, Jitter values for gamma T and gamma R are controlled by TDP.
8. Unfiltered, 20-80%. Complies with IEEE 802.3 (Gig. E), FC 4x eye masks when filtered.
9. Measured with PRBS 2<sup>7</sup>-1 at 10<sup>-12</sup> BER.

## V. General Specifications

Parameter	Symbol	Min	Typ	Max	Units	Ref.
Data Rate	BR	4.25		14.025	Gb/sec	1
Bit Error Rate	BER			$10^{-12}$		2
Supported Link Length on 9/125 $\mu\text{m}$ SMF , 4.25, 8.5, 14.025 Gb/s	$L_{\text{MAX1}}$		10		km	3

### Notes:

1. 4x/8x/16x Fibre Channel compliant.
2. Tested with a PRBS  $2^7-1$  test pattern for 4.25 and 8.5Gb/s operation. Tested with a PRBS  $2^{31}-1$  test pattern for 14.025Gb/s operation.
3. Distances are based on FC-PI-5 Rev. 6.10<sup>1</sup> and IEEE 802.3 standards.

## VI. Environmental Specifications

These Finisar 1310nm Extended Temperature SFP+ transceivers have an operating temperature range from  $-5^{\circ}\text{C}$  to  $+85^{\circ}\text{C}$  case temperature.

Parameter	Symbol	Min	Typ	Max	Units	Ref.
Case Operating Temperature	$T_{\text{op}}$	0		70	$^{\circ}\text{C}$	
Storage Temperature	$T_{\text{sto}}$	-40		85	$^{\circ}\text{C}$	

## VII. Regulatory Compliance

Finisar transceivers are Class 1 Laser Products and comply with US FDA regulations. These products are certified by TÜV and CSA to meet the Class 1 eye safety requirements of EN (IEC) 60825 and the electrical safety requirements of EN (IEC) 60950. Copies of certificates are available at Finisar Corporation upon request.

## VIII. Digital Diagnostic Functions

Finisar FTLF1429P3BCV SFP+ transceivers support the 2-wire serial communication protocol as defined in the SFP MSA<sup>6</sup>. It is very closely related to the E<sup>2</sup>PROM defined in the GBIC standard, with the same electrical specifications.

The standard SFP serial ID provides access to identification information that describes the transceiver's capabilities, standard interfaces, manufacturer, and other information.

Additionally, Finisar SFP transceivers provide a unique enhanced digital diagnostic monitoring interface, which allows real-time access to device operating parameters such as transceiver temperature, laser bias current, transmitted optical power, received optical power and transceiver supply voltage. It also defines a sophisticated system of alarm and warning flags, which alerts end-users when particular operating parameters are outside of a factory set normal range.

The SFP MSA defines a 256-byte memory map in E<sup>2</sup>PROM that is accessible over a 2-wire serial interface at the 8 bit address 1010000X (A0h). The digital diagnostic monitoring interface makes use of the 8 bit address 1010001X (A2h), so the originally defined serial ID memory map remains unchanged. The interface is identical to, and is thus fully backward compatible with both the GBIC Specification and the SFP Multi Source Agreement. The complete interface is described in Finisar Application Note AN-2030: "Digital Diagnostics Monitoring Interface for SFP Optical Transceivers".

The operating and diagnostics information is monitored and reported by a Digital Diagnostics Transceiver Controller (DDTC) inside the transceiver, which is accessed through a 2-wire serial interface. When the serial protocol is activated, the serial clock signal (SCL, Mod Def 1) is generated by the host. The positive edge clocks data into the SFP transceiver into those segments of the E<sup>2</sup>PROM that are not write-protected. The negative edge clocks data from the SFP transceiver. The serial data signal (SDA, Mod Def 2) is bi-directional for serial data transfer. The host uses SDA in conjunction with SCL to mark the start and end of serial protocol activation. The memories are organized as a series of 8-bit data words that can be addressed individually or sequentially.

For more information, please see the SFP MSA documentation<sup>3,6</sup> or Finisar Application Note AN-2030.

FTLF1429P3BCV transceivers can be used in host systems that require either internally or externally calibrated digital diagnostics.

Please note that evaluation board FDB-1027 is available with Finisar ModDEMO software that allows simple to use communication over the 2-wire serial interface.

**IX. Mechanical Specifications**

Finisar’s FTLF1429P3BCV SFP+ transceivers are compatible with the SFF-8432<sup>2</sup> specification for improved pluggable form factor.

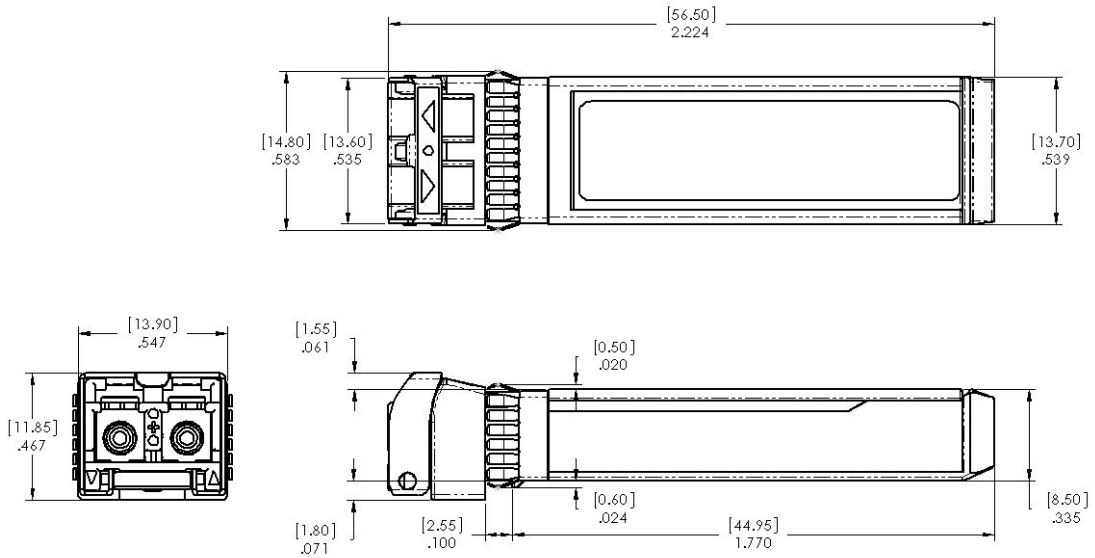

**FTLF1429P3BCV**





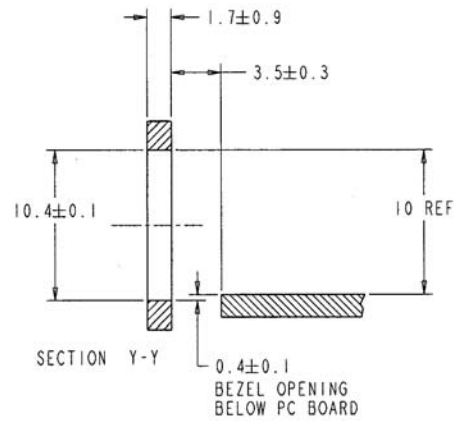
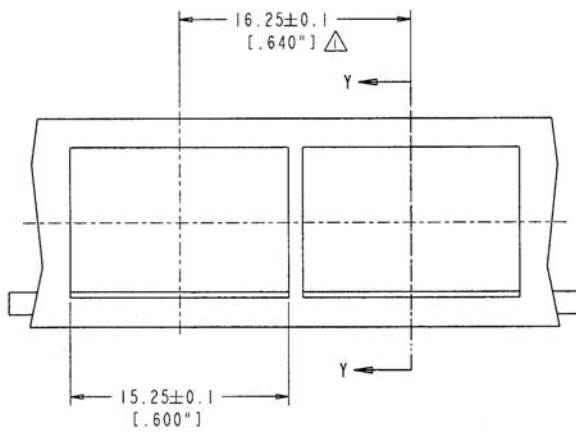
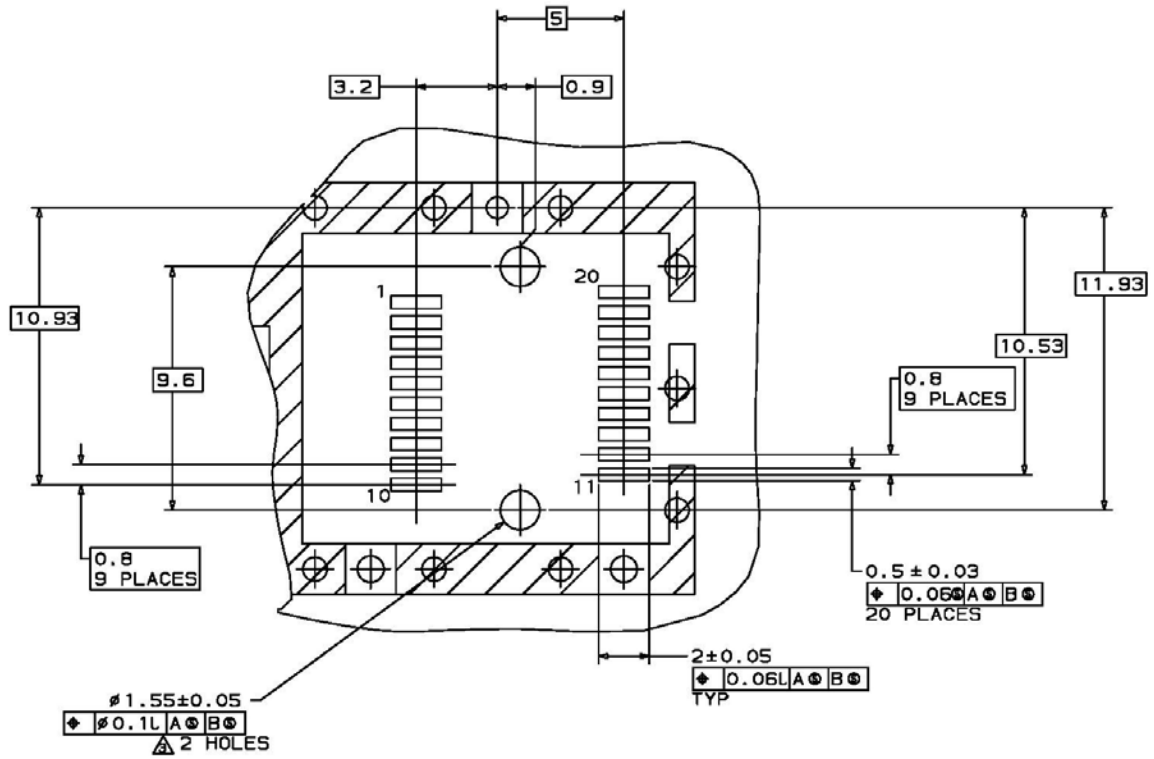

NOTES:

- △ MINIMUM PITCH ILLUSTRATED, ENGLISH DIMENSIONS ARE FOR REFERENCE ONLY
- 2. NOT RECOMMENDED FOR PCI EXPANSION CARD APPLICATIONS

## **XI. References**

1. “Fibre Channel – Physical Interfaces -5, INCITS 479-2011 (*Defines 4GFC, 8GFC and 16GFC*).
2. “Improved Pluggable Formfactor”, SFF Document Number SFF-8432, Revision 5.0, July 16, 2007.
3. “Digital Monitoring Interface for Optical Transceivers”, SFF Document Number SFF-8472, Revision 11.0.
4. “Enhanced Small Form Factor Pluggable Module ‘SFP+ ‘”, SFF Document Number SFF-8431, Revision 4.1, July 6, 2009.
5. Directive 2011/65/EU of the European Council Parliament and of the Council, “on the restriction of the use of certain hazardous substances in electrical and electronic equipment”. Certain products may use one or more exemptions as allowed by the Directive.
6. Small Form Factor Pluggable (SFP) Transceiver Multi-source Agreement (MSA), September 14, 2000 which is available as SFF Document Number INF-8074, Revision 1.0 May 12, 2001.
7. “0.8mm Card Edge Connector for 16Gb/s Applications”, SFF Document Number SFF-8081, Revision 0.2, December 21, 2009

## **XII. For More Information**

Finisar Corporation  
1389 Moffett Park Drive  
Sunnyvale, CA 94089-1134  
Tel. 1-408-548-1000  
Fax 1-408-541-6138  
[sales@finisar.com](mailto:sales@finisar.com)  
[www.finisar.com](http://www.finisar.com)

Data subject to change without notice.



Компания «ЭлектроПласт» предлагает заключение долгосрочных отношений при поставках импортных электронных компонентов на взаимовыгодных условиях!

Наши преимущества:

- Оперативные поставки широкого спектра электронных компонентов отечественного и импортного производства напрямую от производителей и с крупнейших мировых складов;
- Поставка более 17-ти миллионов наименований электронных компонентов;
- Поставка сложных, дефицитных, либо снятых с производства позиций;
- Оперативные сроки поставки под заказ (от 5 рабочих дней);
- Экспресс доставка в любую точку России;
- Техническая поддержка проекта, помощь в подборе аналогов, поставка прототипов;
- Система менеджмента качества сертифицирована по Международному стандарту ISO 9001;
- Лицензия ФСБ на осуществление работ с использованием сведений, составляющих государственную тайну;
- Поставка специализированных компонентов (Xilinx, Altera, Analog Devices, Intersil, Interpoint, Microsemi, Aeroflex, Peregrine, Syfer, Eurofarad, Texas Instrument, Miteq, Cobham, E2V, MA-COM, Hittite, Mini-Circuits, General Dynamics и др.);

Помимо этого, одним из направлений компании «ЭлектроПласт» является направление «Источники питания». Мы предлагаем Вам помощь Конструкторского отдела:

- Подбор оптимального решения, техническое обоснование при выборе компонента;
- Подбор аналогов;
- Консультации по применению компонента;
- Поставка образцов и прототипов;
- Техническая поддержка проекта;
- Защита от снятия компонента с производства.



#### Как с нами связаться

**Телефон:** 8 (812) 309 58 32 (многоканальный)

**Факс:** 8 (812) 320-02-42

**Электронная почта:** [org@eplast1.ru](mailto:org@eplast1.ru)

**Адрес:** 198099, г. Санкт-Петербург, ул. Калинина, дом 2, корпус 4, литера А.